

(19) World Intellectual Property Organization
International Bureau



(43) International Publication Date
25 November 2004 (25.11.2004)

PCT

(10) International Publication Number
WO 2004/101829 A2

(51) International Patent Classification⁷: C21B 13/00, 13/14

(21) International Application Number: PCT/IB2004/001953

(22) International Filing Date: 17 May 2004 (17.05.2004)

(25) Filing Language: English

(26) Publication Language: English

(30) Priority Data: 60/470,437 15 May 2003 (15.05.2003) US

(71) Applicant: HYLSA, S.A. DE C.V. [MX/MX]; Av. Munich 101, San Nicolas de los Garza, Nuevo Leon, 66452 (MX).

(72) Inventors: DUARTE-ESCARENO, Pablo-Enrique; Juan E. Lopez 2807, Cumbres 4o. Sector, Monterrey, Nuevo Leon 64610 (MX). ZENDEJAS-MARTINEZ, Eugenio; Colombia 339, Colonia Vista Hermosa, Monterrey, Nuevo Leon 64620 (MX). LIZCANO-ZULAICA, Carlos; Honda Vista 106, Colonia Linda Vista, Guadalupe, Nuevo Leon 67130 Mexico (MX).

(81) Designated States (unless otherwise indicated, for every kind of national protection available): AE, AG, AL, AM, AT, AU, AZ, BA, BB, BG, BR, BW, BY, BZ, CA, CH, CN, CO, CR, CU, CZ, DE, DK, DM, DZ, EC, EE, EG, ES, FI, GB, GD, GE, GH, GM, HR, HU, ID, IL, IN, IS, JP, KE, KG, KP, KR, KZ, LC, LK, LR, LS, LT, LU, LV, MA, MD, MG, MK, MN, MW, MX, MZ, NA, NI, NO, NZ, OM, PG, PH, PL, PT, RO, RU, SC, SD, SE, SG, SK, SL, SY, TJ, TM, TN, TR, TT, TZ, UA, UG, US, UZ, VC, VN, YU, ZA, ZM, ZW.

(84) Designated States (unless otherwise indicated, for every kind of regional protection available): ARIPO (BW, GH, GM, KE, LS, MW, MZ, NA, SD, SL, SZ, TZ, UG, ZM, ZW), Eurasian (AM, AZ, BY, KG, KZ, MD, RU, TJ, TM), European (AT, BE, BG, CH, CY, CZ, DE, DK, EE, ES, FI, FR, GB, GR, HU, IE, IT, LU, MC, NL, PL, PT, RO, SE, SI, SK, TR), OAPI (BF, BJ, CF, CG, CI, CM, GA, GN, GQ, GW, ML, MR, NE, SN, TD, TG).

Published: — without international search report and to be republished upon receipt of that report

For two-letter codes and other abbreviations, refer to the "Guidance Notes on Codes and Abbreviations" appearing at the beginning of each regular issue of the PCT Gazette.

(54) Title: METHOD AND APPARATUS FOR IMPROVED USE OF PRIMARY ENERGY SOURCES IN INTEGRATED STEEL PLANTS

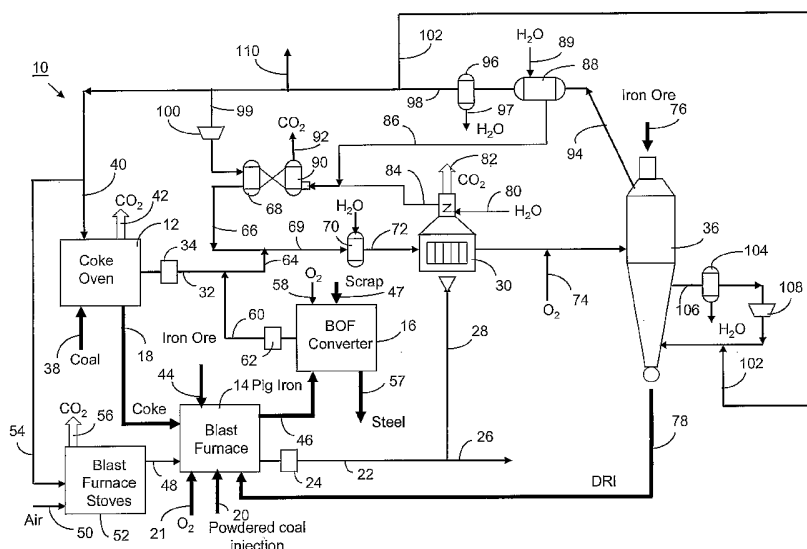

(57) Abstract: A method and an integrated steel plant wherein, instead of using coke oven gases, converter gases and blast furnace top gases available as fuel for power generation or other heating purposes, these gases are more efficiently utilized as chemical agents for direct reduction of iron ores producing DRI. DRI is charged to blast furnaces increasing production of crude steel without increasing the capacities of the coke oven plant and blast furnaces and without changes in the quality of the crude steel, or, if production rate is maintained, the fossil fuels specific consumption is significantly reduced. Utilisation of primary fossil energy according to the invention also reduces the specific CO₂ emissions per ton of crude steel. The specific CO₂ emission in conventional integrated mills is about 1.6 tons of CO₂ per ton of crude steel.

WO 2004/101829 A2

Method and apparatus for improved use of primary energy sources in integrated steel plants

Field of the invention

5 The present invention refers to the field of integrated steel plants of the type comprising blast furnaces (BF) and blast oxygen converters (BOF) for production of crude liquid steel and coke ovens (CO) for supplying the necessary coke to the blast furnaces. More particularly, the invention refers to an improved method of utilizing the chemical values of the gases produced by BF, CO and BOF within a steel plant
10 with advantages in energy efficiency and decreased environmental impact as measured by the amount of carbon dioxide released to the atmosphere.

Background of the invention

 Current steel production in the world is mostly based on integrated steel plants comprising blast furnaces and basic oxygen converters. Blast furnaces require coke
15 which is prepared by carbonization of coal in coke ovens generally located close to the blast furnaces. These three units produce a considerable amount of surplus gases which are used for power generation or heating purposes in other areas of the steel plant, for example, blast air heating stoves, boilers, soaking pits, heat treating furnaces in rolling mills, and some plants burn the non-utilized portion in flare stacks.

20 Increasing prices for energy, mainly for coke, and environmental restrictions, related to CO₂ emissions, have led to consideration of using available energies from integrated steelworks mainly for steel production instead of for power generation and other uses. Additionally, current increasing prices of scrap, DRI/HBI and other iron raw materials as well as the prevailing market fluctuations have generated a need of
25 finding alternatives for the production of metallic iron at less cost by utilization of the chemical reducing potential of blast furnace gas (BFG), coke oven gas (COG) and blast oxygen furnace gas (BOFG).

 Sometimes power generation does not fit the local electricity markets and these projects are not viable. Power generation also does not make optimum use of
30 the chemical values of these gases. By incorporation of a direct reduction plant for reducing iron ores, the DRI produced with the COG and BOFG can be charged to the BF to decrease its consumption of coke and/or powdered coal injection (PCI), or alternatively, for increasing the production of hot metal with the same fossil fuels consumption, thus increasing the crude steel production of the integrated plant, as

well as rendering the steel production facilities more environmentally fit by lowering the amount of CO₂ released to the atmosphere per ton of steel. A further possibility is to increase the production of crude steel by melting the DRI with additional scrap in an electric arc furnace (EAF), without increasing the process capacity of BF and CO.

5 U.S. patent No. 4,889,323, the disclosure of which is hereby incorporated by reference for the teachings of process conditions therein, describes a mill arrangement for the production of steel wherein a direct reduction (DR) reactor is operated with a reducing gas prepared from an oxygen converter gas, off gas from the reduction reactor and coke oven gas. Coke oven gas is utilized after its
10 fractionation by alternating pressure adsorption so as to increase its portion of hydrogen and lower its portion of hydrocarbons and also the COG is desulphurized and passed through a pressure swing adsorption (PSA) process. The reducing gas utilized in the reduction reactor is a mixture of the treated converter gas and the treated coke oven gas. DRI produced in the DR reactor is charged as coolant to the
15 converter in substitution of steel scrap or to electric arc furnaces for the production of steel.

The process of this patent is addressed to the substitution of steel scrap charged to converters and does not teach or suggest either charging DRI to the blast furnace thus increasing the pig iron production, or the advantage of decreasing the
20 specific amount per ton of steel of CO₂ released to the atmosphere.

U.S. patent No. 4,822,411, the disclosure of which is hereby incorporated by reference for the teachings of process conditions therein, describes an arrangement of an integrated steel plant similar to that of the above-mentioned patent wherein a direct reduction plant is incorporated in the steel plant for the purpose of increasing
25 the amount of steel produced without expansion of the capacities of the blast furnace and coking plant.

This patent suggests to increase the production of steel by charging the metallic iron obtained through the direct reduction reactor to the steel converters, while the amount of hot metal produced by the blast furnace remains the same. It
30 also proposes to upgrade the reducing quality of coke oven gas by mixing it with gas from the oxygen converter and optionally with off-gas from the reduction reactor and reforming it in a catalytic reformer which is a huge piece of equipment implying high capital, operating and maintenance costs. This patent does not teach or suggest i) charging DRI to the blast furnace, thus increasing the pig iron production, ii) using the

blast furnace gas for heating the reducing gas fed to the direct reduction reactor, or
iii) the advantage of decreasing the specific amount per ton of steel of CO₂ released
to the atmosphere.

U.S. patent No. 4,248,624, the disclosure of which is hereby incorporated by
5 reference for the teachings of process conditions therein, discloses a method for
operating a blast furnace wherein a portion of a charge is pre-reduced iron ore with a
relatively low metallization and a relatively high carbon content. This patent teaches
using as a portion of the charge to a blast furnace, metallic iron as sponge iron, thus
improving the productivity of the blast furnace and decreasing the specific coke rate.
10 This patent does not suggest either the preparation of reducing gas for sponge iron
production by combining coke oven gas and oxygen converter gas or the reduction of
CO₂ emissions per ton of steel as a consequence of charging pre-reduced materials
to the blast furnace.

Summary of the invention

15 While the general concept of increasing the steel production without increasing
the capacity of the blast furnace and coke ovens has been contemplated by the prior
art, the form of achieving such a production increase has been complex and requires
additional process equipment. The present invention achieves the production
increase in a simpler manner and also achieves a significant reduction of fossil fuels
20 specific consumption, e.g. in the way the production is increased, the specific
consumption of fossil primary energy is lowered.

The optimised utilisation of primary fossil energy according to the invention
also has the effect of significantly reducing the specific CO₂ emissions per ton of
crude steel. The specific CO₂ emission via the conventional BF/BOF route is about
25 1.6 tonnes (t) of CO₂/t crude steel. Utilising the process of the present invention,
DRI, produced with the use of COG and BF top gas, as a metallic charge to the BF or
in an EAF, allows significant reductions in absolute and/or specific CO₂ emissions.

It is therefore an object of the invention to provide a process and apparatus for
operating an integrated steel plant wherein the capacity of steel production is
30 increased without the need of increasing the capacity of the associated coking plant
and blast furnaces.

It is another object of the invention to provide a process and apparatus for
decreasing the specific consumption of fossil fuels per ton of steel produced in an
integrated steel plant.

It is a further object of the present invention to provide a process and apparatus for decreasing in an integrated steel plant the amount of carbon dioxide produced per ton of steel.

5 Other objects of the invention will be pointed out in this specification or will be evident to those skilled in the art.

The objects of the invention are generally achieved by carrying out the method of increasing the production of steel in an integrated steel plant comprising a blast furnace for pig iron production, an oxygen converter for steel production and a coking
10 plant for coke production, without increasing the production capacities of the blast furnace and the coking plant, by incorporating in the integrated steel plant a direct reduction reactor for producing direct reduced iron. The method comprises withdrawing and conditioning the temperature and pressure of gases effluent from the coking plant to form a first gas stream having a hydrogen content in excess of
15 about 50% by volume and a low carbon monoxide content of less than about 10% by volume; withdrawing and conditioning the temperature and pressure of gases effluent from the basic oxygen converter to form a second gas stream having a hydrogen content less than about 10% by volume and a carbon monoxide content higher than about 50% by volume; mixing said first and second streams to form a
20 third gas stream having a reducing potential higher than about 0.6, a hydrogen content higher than about 30% by volume and a carbon monoxide content higher than about 30% by volume; combining the third gas stream with a portion of regenerated gas effluent from the reduction reactor to form a fourth gas stream; heating said fourth gas stream to a temperature higher than about 850°C in a gas
25 heater; introducing iron-oxide-containing solid particles into the reduction reactor and discharging direct reduced iron particles from the reduction reactor; feeding the hot fourth gas stream to the reduction reactor to reduce iron oxides therein into metallic iron and producing the direct reduced iron; withdrawing reacted gas from the reduction reactor as a fifth gas stream; removing water and carbon dioxide from at
30 least a portion of the fifth gas stream to regenerate its reducing potential, thereby forming a sixth gas stream; combining at least a portion of the sixth gas stream with at least a portion of the third gas stream to form the fourth gas stream; and charging the direct reduced iron to the blast furnace.

In another embodiment, the production of steel in an integrated steel plant is increased by converting coal to coke in the coke oven, and forming a first gas stream having a hydrogen content of at least about 50% by volume and a carbon monoxide content of less about 10% by volume by withdrawing and conditioning the temperature and pressure of the coke oven effluent gases. The coke, iron ore and air are charged to the blast furnace, wherein the iron ore is converted to pig iron. The pig iron and oxygen are charged to the oxygen converter wherein the pig iron is converted to steel. A second gas stream having a hydrogen content of less than about 10% by volume and a carbon monoxide content of at least about 50% by volume is formed by withdrawing and conditioning the temperature and pressure of the oxygen converter effluent gases. A third gas stream, having a reducing potential greater than about 0.6, a hydrogen content greater than about 30% by volume, and a carbon monoxide content greater than about 30% by volume, is formed by mixing the first and second gas streams. A fourth gas stream is formed by combining at least a portion of the third gas stream with at least a portion of regenerated gas effluent from the direct reduction reactor. This fourth gas stream is heated to a temperature of greater than about 850°C, and then is introduced, together with iron oxide-containing solid particles, into the direct reduction reactor wherein the solid particles are converted to metallic iron in the form of direct reduced iron. A fifth gas stream is formed by withdrawing reacted gas from the direct reduction reactor. At least a portion of the fifth gas stream is subjected to water and carbon dioxide removal, with collection of the separated carbon dioxide, to form a sixth gas stream with regenerated reducing potential. At least a portion of the sixth gas stream is used in the formation of the fourth gas stream. The direct reduced iron from the direct reduction reactor is charged to the blast furnace. One portion of the gas effluent from the direct reduction reactor can be used to heat air which is injected into the blast furnace, and another portion of the gas effluent from the direct reduction reactor can be introduced as fuel into the coke oven.

The following abbreviations are used in this specification for brevity:

30	BF	blast furnace
	BFG	blast furnace gas
	BOF	blast oxygen furnace converter
	BOFG	blast oxygen furnace gas
	CO	coke oven

	COG	coke oven gas
	DRI	direct reduction iron
	PCI	powdered coal injection
	EAF	electric arc furnace
5	PSA	pressure swing adsorption
	tHM	ton of pig iron

Except as noted herein the process conditions, such as temperatures, pressures, mass flows, etc. in the various components of the integrated steel plant of the present invention are conventional and well known in the art. For instance, such conditions are disclosed in "The Making, Shaping and Treating of Steel", 10th Edition, Association of Iron and Steel Engineers, 1985, the disclosure of which is hereby incorporated by reference.

Brief description of the drawings

Figure 1 is a schematic diagram of an integrated steel mill incorporating the present invention, showing the multiple exchange of materials and energy among the relevant production units within such plant.

Figure 2 is a graph showing the relationship between the amount of powdered coal injected to the blast furnace and the amount of oxygen.

Detailed description of the invention

Referring to Figure 1, numeral **10** generally designates an integrated steel works comprising a CO **12**, a BF **14** for production of pig iron and a BOF **16**. An integrated steel plant normally further comprises a ladle furnace and thin slab caster or compact strip plant (CSP) for the production of hot rolled coils, but these conventional, elements are not shown in the figure for simplicity of the description in the invention.

The development of the BF process during the last 30 – 40 years has decreased the average coke/coal - consumption to about 470 kg/t HM. Through this development, other fuels like oil or coal have replaced coke, so that a BF nowadays can operate with about 300 kg coke/t HM identified by numeral **18** plus about 170 kg of injected powdered coal (PCI) **20** combined with oxygen **21**.

BFG **22** is generated by partial combustion of carbon (coke/coal) with air. Typical compositions of BFG comprise about 4% H₂, about 24% CO and about 23% CO₂ and the rest is mostly N₂ which originates from the air blast injected to the BF.

For many years the use of BFG for purposes other than for the firing of stoves and boilers was not economical due to its high Nitrogen content. BFG, after collection and conditioning to temperature and pressure at conditioning station **24** has been used in the past as fuel in coke ovens, soaking pits and reheating furnaces shown only as a branching pipe **26**. According to the invention a portion **28** of BFG **22** is utilized to heat the reducing gas for the direct reduction reactor in heater **30**.

The composition and amount of gases in an exemplary integrated plant are shown in Table 1.

COG is a by-product of coke manufacture in coke ovens **12** which is produced during the carbonisation or destructive distillation of bituminous coal in the absence of air. As compared to BFG, COG **32** after treatment for pressure and temperature and sometimes sulphur removal at conditioning plant **34** has about 5 to 6 times higher calorific value than BFG. COG has a wider use than BFG because of its relatively low distribution costs, due to its low specific gravity and high calorific value. COG produces extremely high temperatures upon combustion and it can release heat at a high rate while not requiring excessively large combustion chambers.

**Table 1. Mass and Energy Flows of Plants/Systems
in an Integrated Steel Plant**

Item	Unit	Blast Furnace	Coke Oven Plant	BOF converter
Fuel Inputs		<u>Unit/t HM</u>	<u>Unit/t coke</u>	<u>Unit/t LS</u>
Coke	GJ/t	8,99		
	Kg/t	300		
PCI	GJ/t	4,72		
	Kg/t	168		
Coking coal	GJ/t		39,91	
	t/t		1,22	
Additional fuel/energy	GJ/t	0,02	3,45	
	kWh/t			25
Off Gases				
<u>Flows</u>		<u>Unit/t HM</u>	<u>Unit/t coke</u>	<u>Unit/t LS</u>
Mass flow	Nm ³ /t	891,8	418,1	8.690
Energy	GJ/t	3,05	7,27	0,75
<u>Composition</u>				
H ₂	Vol. %	3,9	62,3	6,5
CO	Vol. %	23,7	5,9	62,7
CO ₂	Vol. %	23,2	1,4	17,0
CH ₄	Vol. %	49,2	23,9	13,8
C _n H _m	Vol. %		1,9	
N ₂	Vol. %		4,6	
H ₂ S	g/ Nm ³		0,19	
LHV	MJ/ Nm ³	3,42	17,39	8,63

- 5 Sulphur (as H₂S) present in untreated (not desulphurized++) COG presents certain disadvantages in its usage, particularly when heating certain grades of alloy steel for rolling. Sulphur presence also requires the use of materials resistant to sulphur attack in pipelines, valves and burners.

For the carbonisation process the coke oven furnaces **12** require fuel for heating. In this regard, coke oven plants have a high flexibility for use of fuels from different sources, including BFG and their own generated COG. Low-calorific-value
5 BFG is used as fuel in coke oven furnaces and hot stoves of the BF, while the high calorific coke oven gas can be used for other consumers like rolling mills and power plants. Production of hot COG is approximately 420 Nm³/t of coking coal.

A typical composition of treated COG **32** is indicated in Table 1 above. However, COG without any treatment may be used in the direct reduction reactor **36**
10 for production of DRI.

Coke oven plant **12** converts coal **38** into coke **18** by heating said coal and separating volatile components as COG **32**. Off-gas **40** effluent from direct reduction reactor **36** is used as fuel in coking plant **12**, producing flue gases **42** containing CO₂ which are emitted to the atmosphere.

15 Iron ore, sinter and fluxes **44** are fed to BF **14** where molten pig iron **46** is produced by reduction of iron ore and sinter by carbon monoxide and hydrogen generated from the partial combustion of coke and hot air **48**. Cold air **50** is heated in stoves **52** by heat exchange with refractory materials inside stoves which store heat from combustion of fuel gases **54** effluent from the reduction reactor **36** in a manner
20 known in the art. Combustion of fuel gases in the stoves **52** produce carbon dioxide **56** which is vented as flue gas.

Molten pig iron **46** is further processed and converted into steel **57** in a BOF **16** by adjusting carbon and other elements present in the composition of pig iron **46** and scrap **47** by blowing oxygen **58**. During the blowing time, the amount of BOFG
25 normally generated in the converter is in the range of 0.75 GJ or about 80 to 90 Nm³/ton of liquid steel. BOFG **60**, mainly composed of carbon monoxide and carbon dioxide, is collected, cooled and purified in conditioning plant **62**. The gas conditioning plant may include a gasholder (not shown for sake of simplicity), which functions as a buffer for continuous delivery of BOFG. Currently, BOFG is flared or
30 used in reheating furnaces. A typical composition of BOFG **60** after treatment at conditioning plant **62** is shown in Table 1.

In a conventional integrated steel mill, about 32% of the fossil primary energy (comprising coal and PCI) is transformed into surplus gas, which in most cases is currently used for power generation. The total amount of electric power which can be

produced, assuming 36% efficiency, is in the range of 560 kWh/t HRC. About 220 kWh/t HRC are used for in-plant requirements and the rest, 340 kWh/t HRC, is exported outside the plant.

5 The hydrogen and carbon monoxide content of COG and BOFG make them suitable for the reduction of iron ores, while BFG, given its high Nitrogen content, is used as fuel for reduction gas heating and for steam/power generation.

According to the invention, COG **32**, having a high content of hydrogen higher than about 50% by volume and BOFG **60** are used for reduction of iron ores in a DR reactor **36**. These gas streams **32** and **60** are combined forming gas stream **64**. This
10 gas stream **64** has a composition better suited for reduction of iron ores, e.g. about 37% hydrogen and about 31% carbon monoxide by volume. The content of carbon dioxide however is about 8% and methane about 13% by volume. The proportion of these compounds is decreased by combining gas stream **64** with stream **66** effluent from the reduction reactor **36** after having been treated in CO₂ absorber **68**. Gas
15 stream **66** has a composition by volume of about 36% H₂; 24% CO; 2% CO₂ and 7% CH₄ by volume. The resulting combined gas stream **69** is saturated with water at humidifier **70** as stream **72** which is heated at gas heater **30** to a temperature above about 850°C, preferably between 900°C and 950°C.

An oxygen containing gas **74**, for example air, oxygen enriched air in various
20 proportions or pure oxygen is injected and combined with hot gas stream **72** to further increase the temperature, providing energy for conversion of methane to H₂ and CO according to the self-reforming process technology wherein the reducing gas fed to the reduction reactor is efficiently produced in the reduction section of reactor **36** promoted by the catalytic action of metallic iron present in the DRI produced in
25 said reduction zone. Partial combustion of COG with oxygen before the reactor inlet provides the additional energy, which is required for natural gas reforming in-situ, and for the carburisation of the metallic iron. Contrary to prior art proposals, with this self-reforming process an external reformer unit or an alternate reducing gas generation system are not needed.

30 Because of partial combustion, the reducing gas temperature at the reactor inlet is very high e.g. above about 1000°C. Due to the endothermic behaviour of the combined chemical reactions taking place inside the reactor, the resulting temperature at the reduction zone is below the potential condition for material cluster formation.

The degree of metallization and carbon content can be controlled independently by adjusting the key process parameters and the gas composition in each of the reducing and cooling gas loops of the reduction reactor.

5 The reactor **36** operates at elevated pressure (preferably about 6 bar absolute), allowing a high reactor productivity of about 10 t/h per m² and minimising dust losses through top gas carry-over. This is reflected in low iron ore consumption, which allows the operating costs to be kept low.

10 Iron ore particles **76** in form of pellets, lumps or mixtures thereof, are fed to reactor **36** through suitable conventional charging mechanisms (not shown) forming a downwardly moving bed. The bed descends by gravity through the reactor in counter-flow with the reducing gas. The rate of flow of the particles bed is regulated by suitable mechanisms known in the art, for example a rotary valve or a vibrating conveyor. DRI **78** is discharged from the reactor and charged to the blast furnace **14**.

15 Water **80** is heated by flue gases **82** of heater **30** and converted into steam **84** which together with steam **86** produced at heat exchanger **88** is utilized at CO₂ stripper **90** to regenerate the absorbing solution in a manner known in the art. High purity CO₂ **92** removed from stripper **90** is collected and sold for further use in other industries. This selective removal of CO₂ **92**, which is an important feature of the present invention, decreases the amount of total CO₂ released to the atmosphere by
20 the integrated steel plant.

Reducing gas **94** is withdrawn from reactor **36** after having reacted with iron oxides **76** and is passed through heat exchanger **88** where some of its sensible heat is used to produce steam **86** from water **89** and thereafter it is treated for regeneration of its reducing potential by cooling and cleaning with water at cooler **96**
25 where water **97** is condensed and separated from the gas stream **94**. Hot water **97** is advantageously used for humidifying the combined recycled reducing gas **69** at humidifier **70**. The main portion of de-watered gas **98** is sent as stream **99** to a compressor or pumping means **100** and passes through CO₂ absorber **68** thereby increasing its reducing potential and eventually is recycled to reduction reactor **36**.

30 Another portion **102** of gas stream **98** is sent as make-up to the cooling zone of the reactor **36**. This cooling gas **102** is circulated in the lower zone of reactor **36**, counter-currently to the high-temperature DRI produced in its upper zone in order to bring the temperature of said DRI down to levels below about 100°C and preferably below about 80°C, avoiding in this way any possible re-oxidation which might occur

by contact of metallized DRI particles with oxygen and water of ambient air. This DRI cooling allows the DRI to be handled in open conveyors and transporters for being charged to BF **14** and also permits its open air storage. Alternately, if the economics of a hot briquetting process is low enough, DRI can be hot briquetted and the cooling gas and equipment eliminated by discharging DRI at high temperatures directly to briquetting machines (not shown). In one preferred embodiment of the invention, DRI **78** is cooled down to a temperature less than about 80°C and moved in open conveyors to BF, storage or to other points of utilization. Cooling gas **106** is removed from reactor **36**, cooled and cleaned in water-cooler **104** and recycled by means of compressor **108**.

Another portion **110** of gas **98** may be vented as a purge of inert gases from the reduction system and as a means for pressure control.

For the most optimised DR process scheme, a surplus of purge gas will exist, mainly due to the need for a purge of N₂, which is highly concentrated in the BOFG. Excess of purge gas **54** from the reduction circuit is sent to the steelworks for use in the coke oven plant **12** and/or in a rolling mill or for power generation. The amount of recycled gas **99** through the CO₂ removal system influences the DRI production rate and consequently the amount of purge gas **54** and **110**. Depending on the DRI demand and additional fuel needs for the different facilities in the steel works, the rate of production of DRI can be set in response to said demand and fuel needs. The proper balance will be determined by the particular characteristics and capacities of each plant.

A further aspect of the invention is that its application allows an integrated plant to improve its capability of complying with environmental restrictions related to CO₂ emissions, which are of economical importance due to regulations/trading aspects envisioned in the Kyoto Protocol.

The advantages of the invention can be summarized as follows: (1) Decrease of about 13% to 28% of fossil fuel consumption (coal) and decrease of about 23% to 34% of non-selective CO₂ emissions; (2) Potential increase of about 24% of hot metal by incorporating a DR reactor and keeping the same production rate. The cost of producing liquid steel can be decreased by about 10 US\$ /ton; and (3) Potential increase of about 38% of liquid steel by installing electric arc furnace facilities. In this case, the cost of crude steel can be reduced by about 22 US\$/ton.

Examples

The following cases were analysed by applicants for improving overall energy consumption, CO₂ emissions and production costs in typical integrated steel works.

5 A typical BF uses 300 kg of coke and 170 kg of powdered coal injection to BF (PCI) per ton of pig iron (tHM). Considering this energy input, the maximum DRI production, utilizing all available COG and BOFG, is about 350 kg/tHM, with 94% metallization and 4% carbon content. Metallization is defined as the ratio between metallic iron to total iron in DRI. Cold DRI is charged to BF.

10 There are two cases:(1) to keep same liquid steel production rate. The benefit in this case is a reduction of environmental impact due to a decrease of specific coal consumption and consequently of CO₂ emissions because the amount of PCI is lower and therefore the amount of coal burned is less; and (2) to increase pig iron production in the BF, decreasing not only specific consumption rates but CO₂ emissions per ton of pig iron, and consequently achieving savings in production costs.

In case (1) there is a reduction of 18% of PCI/tHM and a potential decrease of CO₂ emission **42, 56, 82** of about 28% less. This figure considers the selective elimination of CO₂ **92** from the DR plant, which should be delivered/disposed for its utilization other than venting it to the atmosphere.

In case (2) there is an increase of 24% of pig iron **46** and liquid steel **57** by charging 0.35 t of DRI/tHM in the BF. Fossil energy consumption **38, 20** decreases by about 13% as PCI/tHM and CO₂ in flue gases is reduced by about 23%.

Figure 2 shows the calculated savings in powdered coal **20** and oxygen **21** injection to BF **14** as a function of the amount of DRI or HBI charged to said BF. At levels of about 250 Kg of DRI/tHM oxygen **21** is not needed and at levels of about 350 kg/tHM the amount of PCI **20** is reduced to about 50 kg/tHM from current levels of about 170kg/tHM. This reduction in PCI contributes to a decrease of the CO₂ emissions because less coal is combusted per ton of liquid steel.

30 It is of course to be understood that the foregoing description of some preferred embodiments of the invention is intended to be illustrative only and that numerous changes can be made in the structure of the system described and its

operating conditions without departing from the spirit of the invention as defined in the appended claims.

CLAIMS

1. A method for producing steel in an integrated steel plant, the plant comprising a blast furnace for pig iron production, an oxygen converter for steel production, a
5 coke oven for coke production and a direct reduction reactor for producing direct reduced iron, the method comprising
- forming a first gas stream having a hydrogen content of at least about 50% by volume and a carbon monoxide content of less than about 10% by volume by withdrawing and conditioning the temperature and pressure of the coke oven effluent
10 gases;
- forming a second gas stream having a hydrogen content of less than about 10% by volume and a carbon monoxide content of at least about 50% by volume by withdrawing and conditioning the temperature and pressure of oxygen converter effluent gases;
- 15 forming a third gas stream having a reducing potential greater than about 0.6, a hydrogen content greater than about 30% by volume, and a carbon monoxide content greater than about 30% by volume by mixing the first and second gas streams;
- forming a fourth gas stream by combining at least a portion of the third gas stream with at least a portion of regenerated gas effluent from the direct reduction reactor;
- 20 heating the fourth gas stream to a temperature of greater than about 850°C;
- reducing iron oxide-containing solid particles in the direct reduction reactor to metallic iron in the form of direct reduction iron by introducing the solid particles and the heated fourth gas stream into the direct reduction reactor;
- 25 forming a fifth gas stream by withdrawing reacted gas from the direct reduction reactor;
- forming a sixth gas stream with regenerated reducing potential by removing water and carbon dioxide from at least a portion of the fifth gas stream;
- 30 using at least a portion of the sixth gas stream in the formation of the fourth gas stream; and charging the direct reduced iron to the blast furnace.
2. Method of claim 1, wherein the fourth gas stream is heated to a temperature of 900°C to 950°C.

3. Method of claim 2, wherein the fourth gas stream is heated by the gases effluent from the blast furnace.
4. Method of claim 1, wherein the fourth gas stream is formed by combining at last a portion of the third gas stream with at least a portion of said regenerated gas
5 that has been cooled and cleaned with water and has had at least a portion of the CO₂ therein removed.
5. Method of claim 1, wherein the rate of production of direct reduced iron in the direct reduction reactor is influenced by the amount of the sixth gas stream used to form the fourth gas stream.
- 10 6. Method of claim 1, wherein the first gas stream and the second gas stream are mixed together prior to either the first or second gas stream contacting gas effluent from the direct reduction reactor.
7. Method of claim 1, including the further step of using a portion of the gas effluent from the direct reduction reactor as fuel in the coke oven.
- 15 8. Method of claim 1, further including charging air, coke and iron ore to the blast furnace, and heating the air charged to the blast furnace in an associated refractory stove.
9. Method of claim 8, wherein the air is heated using a portion of the gas effluent from the direct reduction reactor as fuel in the refractory stove.
- 20 10. The method of claim 1, including the further step of selectively separating and collecting CO₂ from at least a portion of the reducing gases effluent from the direct reduction reactor.
11. Method of claim 1, including the step of injecting powdered coal into the blast furnace.
- 25 12. Method of claim 1, wherein at least a portion of the direct reduced iron discharged from the direct reduction reactor is charged to the blast furnace.
13. A method of increasing pig iron and/or liquid steel production in a blast furnace of an integrated steel plant while reducing CO₂ emissions per ton of pig iron, as compared to conventional integrated steel plants, which plant comprises a blast
30 furnace for pig iron production, an oxygen converter for converting the pig iron into steel, a coke oven for the production of coke charged to the blast furnace, and a direct reduction reactor for producing direct reduced iron, said method comprising
converting coal to coke in the coke oven;

- forming a first gas stream having a hydrogen content of at least about 50% by volume and a carbon monoxide content of less than about 10% by volume by withdrawing and conditioning the temperature and pressure of the coke oven effluent gases;
- 5 charging iron ore, the coke and air to the blast furnace and converting the iron ore to pig iron;
- charging the pig iron and oxygen to the oxygen converter and converting the pig iron to steel;
- forming a second gas stream having a hydrogen content of less than about 10% by volume and a carbon monoxide content of at least about 50% by volume by withdrawing and conditioning the temperature and pressure of oxygen converter effluent gases;
- 10 forming a third gas stream having a reducing potential greater than about 0.6, a hydrogen content greater than about 30% by volume, and a carbon monoxide content greater than about 30% by volume by mixing the first and second gas streams;
- 15 forming a fourth gas stream by combining at least a portion of the third gas stream with at least a portion of regenerated gas effluent from the direct reduction reactor;
- 20 heating the fourth gas stream to a temperature of greater than about 850°C;
- reducing iron oxide-containing solid particles in the direct reduction reactor to metallic iron in the form of direct reduced iron by introducing the solid particles and the heated fourth gas stream into the direct reduction reactor;
- forming a fifth gas stream by withdrawing reacted gas from the direct reduction reactor;
- 25 forming a sixth gas stream with regenerated reducing potential by removing water and carbon dioxide from at least a portion of the fifth gas stream and the separated carbon dioxide is collected;
- using at least a portion of the sixth gas stream in the formation of the fourth gas stream;
- 30 and charging direct reduced iron from the direct reduction reactor to the blast furnace,

wherein one portion of the gas effluent from the direct reduction reactor is used to heat air injected into the blast furnace, and another portion of the gas effluent from the direct reduction reactor is introduced as fuel into the coke oven.

14. Method of claim 13, wherein a portion of the gases effluent from the direct
5 reduction reactor are subjected to CO₂ removal prior to combination with at least a portion of the third gas stream to form the fourth gas stream, and high purity CO₂ so removed is collected.

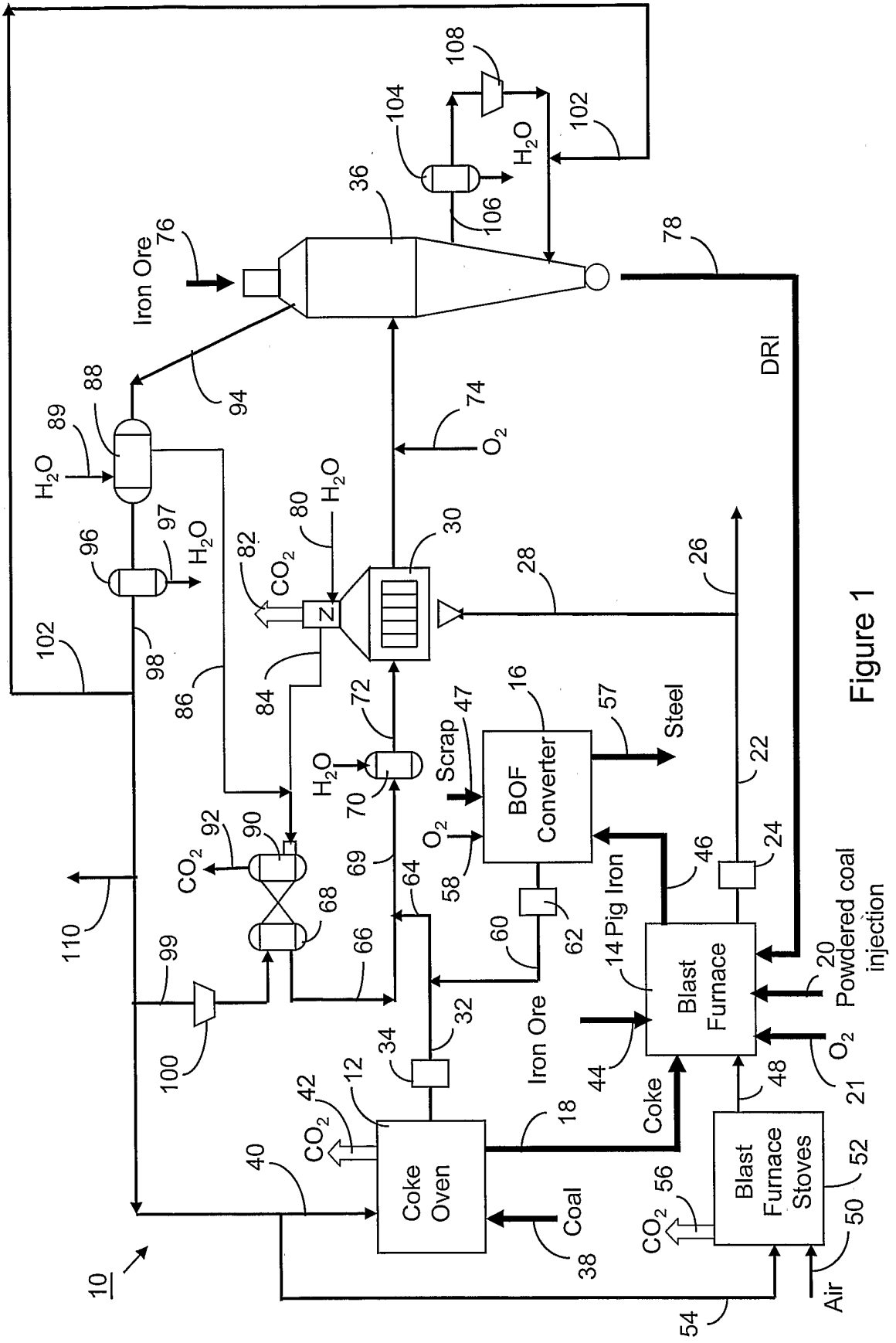

Figure 1

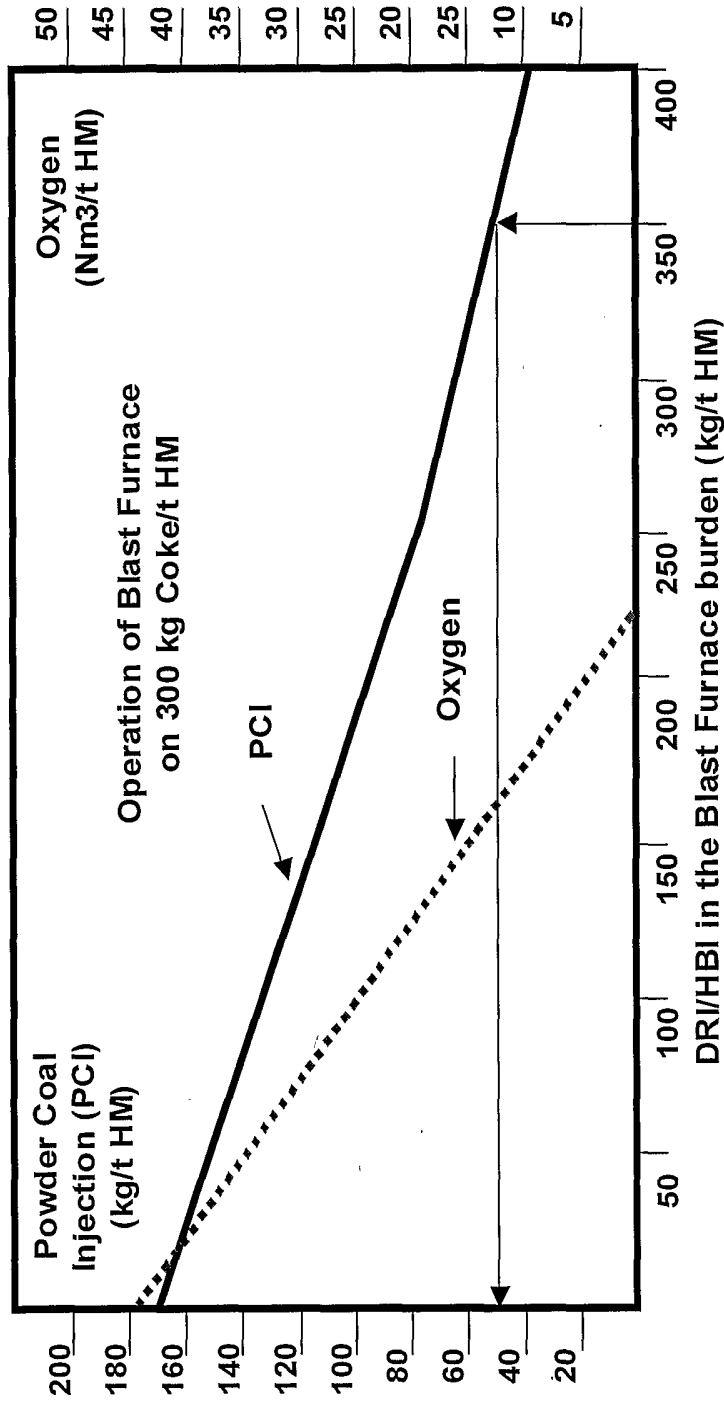

Figure 2