

J. M. HARTMAN.  
BLAST FURNACE.

(Application filed June 26, 1900.)

(No Model.)

2 Sheets—Sheet 1.

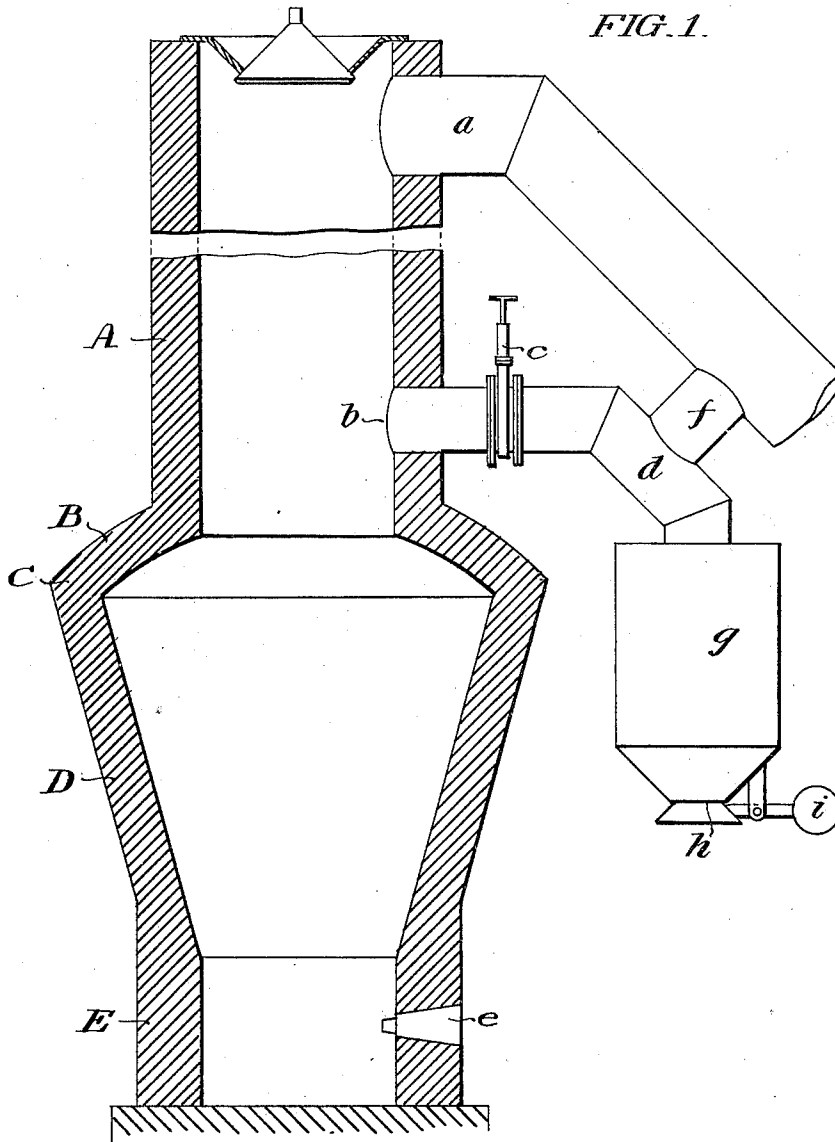

WITNESSES:  
*Samuel Bell*  
*John H. Jenkins*

INVENTOR  
*John M. Hartman*  
by his attorney  
*Friley & Paul*

J. M. HARTMAN.  
BLAST FURNACE.

(Application filed June 26, 1900.)

(No Model.)

2 Sheets—Sheet 2.

FIG. 2.

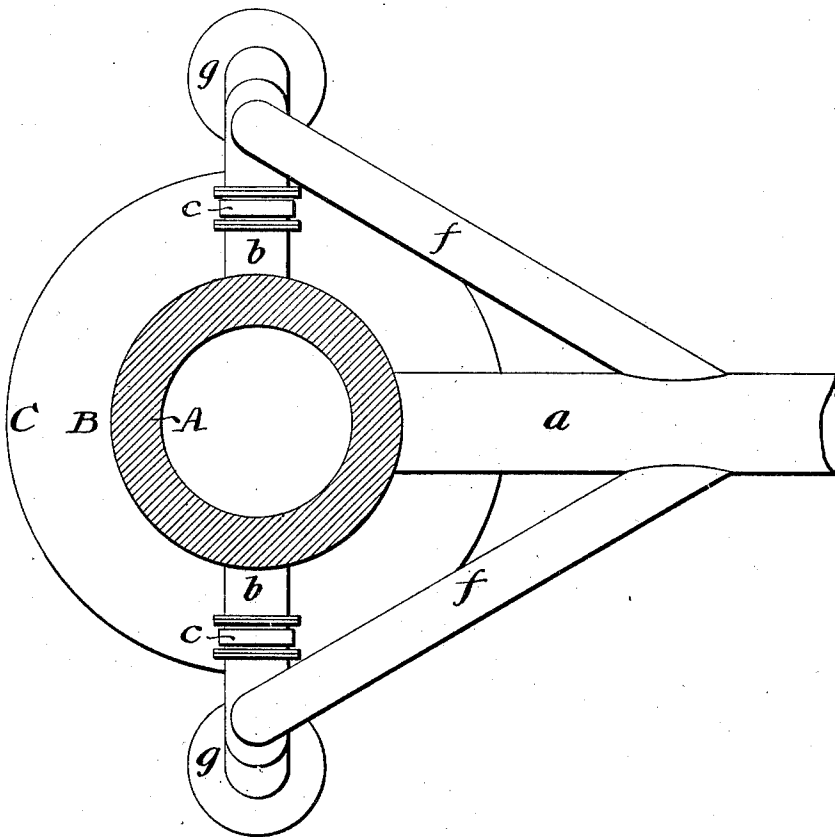

WITNESSES:

*James Bell*  
*Herbert Jenkins*

INVENTOR:

*John M. Hartman*  
*by his Attorneys*  
*Tracy & Paul*

# UNITED STATES PATENT OFFICE.

JOHN M. HARTMAN, OF PHILADELPHIA, PENNSYLVANIA.

## BLAST-FURNACE.

SPECIFICATION forming part of Letters Patent No. 676,692, dated June 18, 1901.

Application filed June 26, 1900. Serial No. 21,593. (No model.)

*To all whom it may concern:*

Be it known that I, JOHN M. HARTMAN, a citizen of the United States, residing on Gowen avenue, Mount Airy, in the city and county of Philadelphia and State of Pennsylvania, have invented certain new and useful Improvements in Blast-Furnaces, of which the following is a specification, reference being had to the accompanying drawings.

My invention relates to certain improvements in the construction of blast-furnaces, by means of which I am able to prevent choking of the stack. If the stack chokes, a blast of very high pressure is required to force its way through it. This choking is partly due to scaffolds forming in the stack and partly to an undue accumulation of fine material. The former I prevent by the insertion at the proper point in the inner wall of the furnace of a relatively flat arch and the latter I prevent by the insertion at the proper place in the stack of the furnace of one or more auxiliary offtakes, through which any undue accumulation of fine dust can be from time to time removed.

In the accompanying drawings, Figure 1 represents, in vertical section, a blast-furnace embodying my invention. Fig. 2 is a horizontal section of a similar furnace having two auxiliary offtakes instead of one.

A represents the shaft of the furnace.

B represents a flat arch uniting the shaft with the top of the bosh C.

D is the bosh; E, the hearth; e, one of the twyers, and a the main offtake, which leads from near the top of the shaft to the stoves, where the gases of the blast are burned.

In order to properly locate the improvements to which my invention relates, it is necessary to have regard to what normally occurs within the furnace, which I will therefore briefly explain.

In a furnace which is working properly and under normal conditions there will always be found superimposed upon each other a definite series of well-defined horizontal zones. At the top of the stack is the "zone of preparatory heating," within which the materials which are fed in at the top of the furnace undergo little change. This zone reaches down to a point which may be closely approxi-

mated by measuring thirty-two per cent. of the distance from the top of the furnace to the center of the twyers. Next below this is the "zone of reduction." It is within this zone that the reduction of the metal from the ore takes place. Simultaneously with the metallic reduction is a disintegration of the materials, which causes them to become gradually finer and finer. The zone of reduction reaches from the bottom of the zone of preparatory heating to a horizontal plane called the "fusion limit." The settlement of this plane is a point of prime importance in determining the details of construction of a blast-furnace. The best rule for ascertaining its position is as follows: Dividing the number of cubic feet of air entering the furnace per minute by five gives the cubic contents of the zone from the center of the twyers up to the fusion limit for a furnace burning charcoal, dividing it by four gives the cubic contents of the same zone for a furnace burning coke, and dividing it by three the cubic contents for a furnace burning anthracite. From the fusion limit, which is thus determined, for the space of three feet downward extends the "zone of fusion." Within this zone the metal as it descends is transformed from a solid to a fluid condition, the top of the zone or the fusion limit being marked by the transformation of the metal from a solid to a pasty or viscous state, while the lower limit is marked by its transformation from a pasty to a fluid state. From the bottom of the zone of fusion to the twyers is the "zone of gasification," through which the molten metal trickles down over the surface of the glowing coals. With this latter zone, however, my present improvements are not concerned.

I will now explain the factors which contribute to cause undue choking of the stack. The first of these is the disintegration of the ore, which reaches its maximum at the fusion limit. This fine material thus formed packs under the pressure of the weight of the material above it. This tendency to pack is augmented by the increasing height of the stack now commonly used in blast-furnace construction. In a stack of great height, filled with material well up to its top (and if

the stack is not thus filled the furnace is not running to its maximum capacity) the part of the shaft above the fusion limit gradually becomes filled with this finely-disintegrated ore and material, which is caused to pack tighter and tighter. This body of finely-powdered material above the fusion limit lies close and compact, and it is here that the strongest resistance to the pressure of the blast occurs. The thickness of this compact mass will vary, and consequently a varying pressure is required to force the blast through it. At times the furnace may disintegrate ore and reduce it above the line of fusion faster than the fuel is burned away at the twyers below, in which case the fine material will accumulate above, requiring increased pressure. The same difficulty may be caused by feeding fine ore accompanied with slow driving or slow burning of the fuel at the twyers. It must be understood, however, that a certain depth of this finely-divided material is required, for in this bed the final offices of reduction and carbonization take place. If the bed is too thin, poor iron results, while on the other hand if the bed is too thick the pressure becomes too high. The difficulty at the point where the compact material accumulates is liable to be increased by the adherence to the walls of the furnace at or about the zone of fusion of clinkers, which gradually increase and form what are known as "scaffolds," forming a throat or constriction just below that point where the greatest pressure of the blast is required. By my invention both these difficulties are removed or minimized. In order to remove the excess of finely-packed material, I provide the stack with one or more auxiliary offtakes, opening into the zone of disintegration, and therefore much lower down than the ordinary offtake at the top of the stack. In the drawings, *b b* represent these auxiliary offtakes, (two only are shown, but any convenient number may be used.) They are controlled by gates *c c*. *d* is a descending portion of the auxiliary offtake, and *f* is a connecting portion through which the gas can escape into the descending portion of the main offtake, sometimes called the "down-comer." *g* is a receptacle placed below the descending portion *d* of the auxiliary offtake and into which the latter opens. *h* is an opening at the bottom of the receptacle *g*, which may be closed by a hinged valve held in place by a counterweight *i*.

The auxiliary offtakes must be located within the horizontal limits of the zone of disintegration and should preferably be not less than eight feet above the bottom of the zone—*i. e.*, above the fusion limit—for the reason that, as has been explained, a moderate depth of finely-divided material is necessary for the proper working of the furnace.

In operation when the pressure of the blast becomes abnormally high by reason of the accumulation of the finely-divided material

the gates *c* of a sufficient number of the auxiliary offtakes are opened, allowing the blast to pass through these offtakes temporarily. This not only relieves the pressure while the blast continues to pass through these auxiliary offtakes, but for a considerably-longer period, by reason of the fact that the blast, passing out of the stack below or at the level where the finely-divided material is accumulated, carries a good deal of this material with it and deposits it in the receptacles *g*. By this method the pressure required at the twyers can be kept almost uniform, for as soon as rising pressure reveals an undue accumulation the valves are opened for a short time. They are then closed and the operation proceeds until another rise of pressure indicates the necessity of again opening them. The fine material blown out and caught in the receptacle *g* is found by analysis to be of the same composition as the material in the stack of the furnace. On mixing this material with a small portion of lime, wetting and allowing it to dry, it becomes hard and can be again used in the furnace. As far as I am aware the only method heretofore proposed or used for relieving this undue pressure has been to stop the filling of the furnace and allow the ore in the stack to descend some forty or fifty feet. When this occurs, the fine material is liable to be blown over through the main offtake, choking it and clogging the stoves and boilers with dust, which must be cleaned out after stopping the furnace. After the dust is blown out the furnace will be refilled, requiring extra fuel and labor. Furthermore, disastrous explosions have occurred where the pressure of the blast has become too high, due to the air-pressure suddenly overbalancing the column of the stack and forcing its way through, when the dust and finely-divided carbon suddenly explodes; but to effectually prevent all choking of the stack above the fusion limit it is necessary to prevent the formation of scaffolds or skewbacks. The formation of these rings of refractory material adhering to the sides of the furnace commences within the zone of fusion and is due to the adherence of some of the pasty material there presented to the walls. When, however, they have once commenced to form, the normal operation of the furnace is interfered with, and they ultimately build up to a considerable height and constrict or choke the furnace at the very point where even in their absence the maximum blast-pressure is required to force the blast through the descending material. To prevent the formation of these scaffolds, I insert a comparatively flat arch coincident with the limits of the zone of fusion, as seen at B, Fig. 1. This arch springs from the top of the bosh, which is a little lower down than the bottom of the zone of fusion and extends up above the fusion limit, where the straight stack begins. As the stock descends through the shaft, it is capable of expanding and

forming a talus at an angle of about forty-five degrees, but no more. The dome or arch B which I construct is so proportioned that no part of the interior of the arch falls below forty-five degrees from the vertical. As the descending stock piles at an angle less than this, it does not reach or touch the under side of the arch. Consequently the pasty material is not forced against the wall of the furnace and does not adhere. By thus preventing its lodgment at this point the beginning of the formation of the scaffold is prevented. To the proper operation of these devices it is hardly necessary to state that means must be provided to keep the furnace working in its normal way. The twyer-circle must be properly proportioned to the fuel to be burned, and the blast must be driven in accordance with its normal and calculated capacity, so as to maintain the zone of fusion at its normal position, for of course if it is allowed to sink or rise from this position by an abnormally low or an abnormally high blast the flat arch will to this extent fail to fulfil its function. It should be observed that to this end the auxiliary offtakes are an important adjunct. If it were not for them, the compacting of the material above the fusion limit would tend to cause variations in the pressure of the blast, and as the pressure increases the zone of fusion lowers. By properly operating the auxiliary offtakes it is possible to maintain the pressure without much variation, and as a consequence it is possible to maintain the zone of fusion at a nearly-constant level and within the limits of the flat arch. By this means the arch becomes effective to perform the functions which I have described and a normal working of the entire furnace can be maintained.

Having thus described my invention, I claim—

1. In a blast-furnace, the combination of the stack; a main offtake at or near the top of the stack; one or more auxiliary offtakes lower down in the stack; and means for maintaining the zone of disintegration within the stack between horizontal planes which are

respectively above and below said auxiliary offtakes, substantially as described.

2. In a blast-furnace, the combination of the stack; a main offtake at or near the top of the stack; one or more auxiliary offtakes lower down in the stack; means for controlling the operation of said auxiliary offtakes; and means for maintaining the zone of disintegration within the stack between horizontal planes which are respectively above and below said auxiliary offtakes, substantially as described.

3. In a blast-furnace, the combination of the stack; a main offtake at or near the top of the stack; one or more auxiliary offtakes lower down in the stack; receptacles communicating with the auxiliary offtakes within which the finely-divided dust passing through them is collected; and means for maintaining the zone of disintegration within the stack between horizontal planes which are respectively above and below said auxiliary offtakes, substantially as described.

4. In a blast-furnace, a stack provided with a relatively flat arch not less than forty-five degrees from the vertical situated above the bosh; and means for maintaining the zone of fusion within the stack between the horizontal planes which mark the top and bottom of the flat arch, substantially as described.

5. In a blast-furnace, a stack provided with a relatively flat arch, not less than forty-five degrees from the vertical, situated above the bosh; means for maintaining the zone of fusion within the stack between the horizontal planes which mark the top and bottom of the flat arch; a main offtake at or near the top of the stack; one or more auxiliary offtakes lower down in the stack; and means for maintaining the zone of disintegration within the stack between horizontal planes which are respectively above and below said auxiliary offtakes, substantially as described.

JOHN M. HARTMAN.

Witnesses:

JAMES H. BELL,  
G. HERBERT JENKINS.