

(No Model.)

E. H. FENTON.  
BROOM.

No. 432,130.

Patented July 15, 1890.

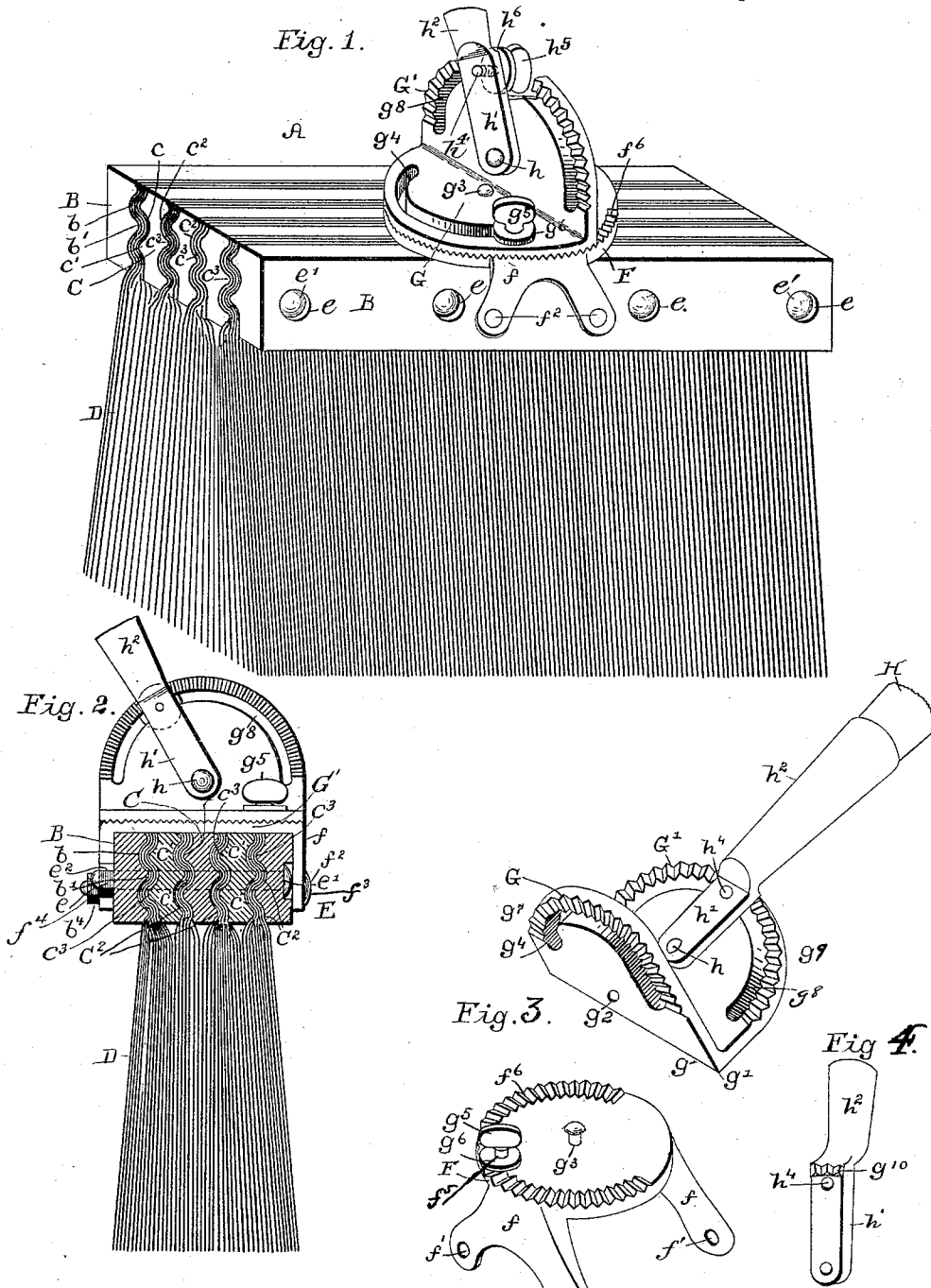

Witnesses:  
*J. S. Fischer*  
*S. L. C. Hasson*

Inventor:  
*Ephraim H. Fenton.*  
By *Richd. W. Manning*  
Att'y.

# UNITED STATES PATENT OFFICE.

EPHRAIM H. FENTON, OF KANSAS CITY, MISSOURI.

## BROOM.

SPECIFICATION forming part of Letters Patent No. 432,130, dated July 15, 1890.

Application filed November 20, 1889. Serial No. 331,033. (No model.)

### *To all whom it may concern:*

Be it known that I, EPHRAIM H. FENTON, a citizen of the United States, residing at Kansas City, in the county of Jackson and State of Missouri, have invented certain new and useful Improvements in Brooms; and I do hereby declare that the following is a full, clear, and exact description of the same, such as will enable others skilled in the art to which it appertains to make and use the same, reference being had to the accompanying drawings, forming a part of this specification.

My invention has for its object to enable the adjustable swivel-plate upon the broom-head to be securely locked in position after its adjustment.

In the drawings, Figure 1 is a view in perspective of the broom, showing the end portion of the broom-head and the fiber between the locking-strips and also the vibrating handle broken away and the adjustable locking attachment. Fig. 2 is a transverse sectional view of the broom as seen in Fig. 1. Fig. 3 is a perspective view of the adjustable attachment for the handle upon the broom-head, showing the parts detached and the locking-serrations on each part. Fig. 4 is a detail view of the pivoted handle-socket.

Similar letters of reference indicate corresponding parts in all of the figures.

In carrying out my invention, A represents the broom-head, which is rectangular in shape. The outer longitudinal sides of the broom-head A are composed of the parallel clamping-strips B B. Upon the inner face portion of each strip B, and parallel with each other a suitable distance apart, are made the grooves  $b$   $b$ , between which grooves are formed projections  $b'$ , the lines of which grooves and projections are extended in the longitudinal direction of said strip. Between the clamping-strips B B and parallel therewith are inserted the separating-strips C C. The strips C C are made of the corresponding width and length to that of the strips B B and of a suitable thickness. In one side of the separating-strip C, a suitable distance apart and parallel with each other and alternating in position in respect to the grooves  $b$  and projections  $b'$  in the clamping-strips B B, are made the grooves  $c$   $c$ , between which grooves are the projections  $c'$   $c'$ . In the other side of the separating-strip

C are made grooves  $c^2$   $c^2$  and intermediate projections  $c^3$   $c^3$ , which extend in a like direction, and are similar in length and width to the grooves  $c$  and projections  $c'$  and are alternately disposed in position in respect to the grooves and projections  $c$   $c'$ , so that the lines of the grooves  $c$   $c$  on each side of strip C are horizontal in position with a projection  $c^3$   $c^3$ . Between the separating-strips C C are fitted additional strips of similar construction in proportion to the increase of the width of the broom-head. Between the clamping-strips B B and the separating-strips C C and between the respective strips is the broom-corn fiber or splints D. Through the broom-head, in a transverse relation to the strips B B and C at suitable distances from each other, are made the perforations  $e$   $e$ , through which are inserted the clamping-bolts E, which are provided with a head  $e'$  at one end and screw-threaded at the other, and upon which screw-threaded end are fitted the nuts  $e^2$ .

For the purpose of enabling the wear upon the broom fiber or splints to be made uniform, a flat plate F, of the proper width, is extended across the head of the broom, and a portion  $f$   $f$  of each end bent downwardly at right angles in line with the outer side portion of the strips B B. Through said portions  $f$   $f$  of plate F and the broom-head is made the perforation  $f'$ , and through said perforation is inserted a securing-bolt  $f^2$ , upon one end of which bolt is a head  $f^3$  and the other end screw-threaded and provided with a nut  $f^4$ . Upon the top portion of the plate F is an adjustable swivel locking-plate G. Said plate G is made, preferably, in the form of a segment of a circle, and extending in a vertical direction from the said segmental plate G is a segmental plate G', the portions of which plates in the line of their respective chords  $g$   $g'$  are placed in alignment and rigidly secured together. Through the perforation  $g^2$  in the plate G, near the line of said chords and extending into and secured rigidly to the plate F, is inserted the pivot  $g^3$ , the length of which pivot is made sufficient to permit a slight elevation of the plate G above the plate F, for the purpose hereinafter described. Extending through plate G and in a curved line described from the pivot  $g^3$  is made a curved slot  $g^4$ . In the plate F, in line with the slot  $g^4$ , is

made a screw-threaded perforation  $f^5$ . In said perforation  $f^5$  is inserted the screw-threaded end of a thumb-screw  $g^5$ , which is pivoted with a binding-shoulder  $g^6$  near the other end.

5 In the under side portion of the plate G, a short distance from and in a similar curved line described at its edge and also extending in radial line toward the pivot  $g^3$ , is made the serrations  $g^7$ . In the upper side portion of

10 the plate F, directly beneath and in line with the curved line of serrations  $g^7$  and extending a distance nearly that of a complete circle, are the serrations  $f^6$ , which are also extended in radial lines toward the pivot  $g^3$ .

15 To the inner side portion of the plate G', above the pivot  $g^3$ , is pivoted on pivot  $h$  the flat portion  $h'$  of the broom-handle socket  $h^2$ . A suitable distance above the pivot  $h$ , in the plate G' and in a curved line described from the

20 said pivot  $h$ , is made a curved slot  $g^8$ . In line with the slot  $g^8$  in the flat portion  $h'$  is made a screw-threaded perforation  $h^4$ , in which is fitted one end of a thumb-screw  $h^5$ , which thumb-screw extends through slot  $g^8$  and is

25 provided with a shoulder  $h^6$ . In the socket  $h^2$  is inserted the broom-handle H. Upon the inner face portion of the plate G, adjacent to the flat portion  $h'$  of the socket  $h^2$  above the curved slot  $g^8$  and in a curved line corresponding thereto, is made the serrations  $g^9$ ,

30 and upon the inner face of the flat portion  $h'$  of the socket  $h^2$  is made the serrations  $g^{10}$ , so that after an adjustment of the handle is made the teeth prevent slipping of the handle

35 from a fixed point.

The broom in service in resisting the power given to the handle, especially in heavy brooms, requires, in addition to the adjustment of the handle at varying angles, a security from accidental movement, which is 40 attained when the adjustments are made by means of the serrations heretofore described.

Having fully described my invention, what I now claim as new, and desire to secure by Letters Patent, is—

1. The combination, with a broom-head 45 having a handle, of a fixed plate, an adjustable swivel-plate pivotally attached to one end portion of said handle and also to said fixed plate, and means for adjusting said 50 swivel-plate in its circle of rotation, and interlocking teeth on the contiguous surface of said fixed and said swivel plates, for the purpose described.

2. The combination, with a broom having 55 a handle and a suitable broom-head, of a plate on said broom-head having a vertical extension pivotally attached to one end of said handle and said extension provided with a curved slot described in said extension from 60 said pivot, an adjustable binding-screw extending through said slot into said handle, and interlocking serrations on the adjacent sides of said vertical plate and said handle, for the purpose described.

EPHRAIM H. FENTON.

Witnesses:

O. J. FLEMING,  
S. L. C. HASSON.