

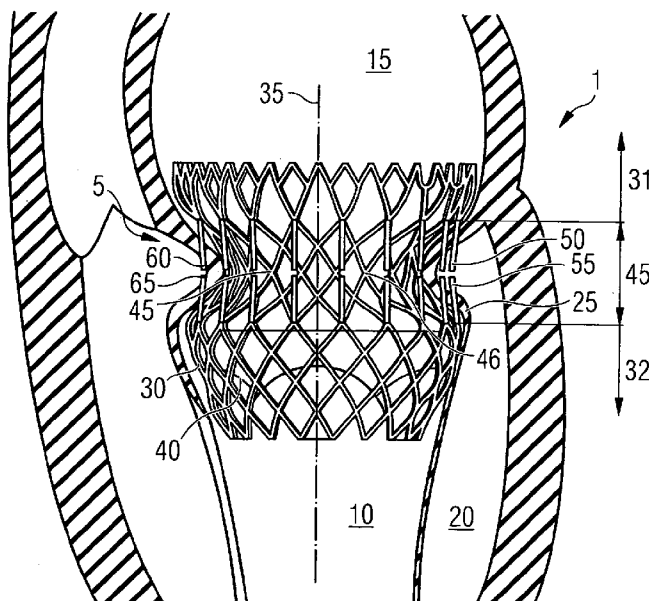

- (51) International Patent Classification:  
A61F 2/24 (2006.01)
- (21) International Application Number:  
PCT/EP2012/061237
- (22) International Filing Date:  
13 June 2012 (13.06.2012)
- (25) Filing Language: English
- (26) Publication Language: English
- (30) Priority Data:  
10 2011 053 520.9  
12 September 2011 (12.09.2011) DE  
10 2011 054 172.1  
4 October 2011 (04.10.2011) DE  
61/543,331 5 October 2011 (05.10.2011) US
- (71) Applicant (for all designated States except US): **HIGH-LIFE SAS** [FR/FR]; 25 rue de Choiseul, F-75002 Paris (FR).
- (72) Inventors; and
- (75) Inventors/Applicants (for US only): **BÖRTLEIN, Georg** [DE/FR]; c/o 25 rue de Choiseul, F-75002 Paris (FR). **NASR, Malek** [FR/FR]; c/o 25 rue de Choiseul, F-75002 Paris (FR).
- (74) Agent: **VIERING, JENTSCHURA & PARTNER**; Grillparzerstr. 14, 81675 Muenchen (DE).
- (81) Designated States (unless otherwise indicated, for every kind of national protection available): AE, AG, AL, AM, AO, AT, AU, AZ, BA, BB, BG, BH, BR, BW, BY, BZ, CA, CH, CL, CN, CO, CR, CU, CZ, DE, DK, DM, DO, DZ, EC, EE, EG, ES, FI, GB, GD, GE, GH, GM, GT, HN, HR, HU, ID, IL, IN, IS, JP, KE, KG, KM, KN, KP, KR, KZ, LA, LC, LK, LR, LS, LT, LU, LY, MA, MD, ME, MG, MK, MN, MW, MX, MY, MZ, NA, NG, NI, NO, NZ, OM, PE, PG, PH, PL, PT, QA, RO, RS, RU, RW, SC, SD, SE, SG, SK, SL, SM, ST, SV, SY, TH, TJ, TM, TN, TR, TT, TZ, UA, UG, US, UZ, VC, VN, ZA, ZM, ZW.
- (84) Designated States (unless otherwise indicated, for every kind of regional protection available): ARIPO (BW, GH, GM, KE, LR, LS, MW, MZ, NA, RW, SD, SL, SZ, TZ, UG, ZM, ZW), Eurasian (AM, AZ, BY, KG, KZ, RU, TJ, TM), European (AL, AT, BE, BG, CH, CY, CZ, DE, DK, EE, ES, FI, FR, GB, GR, HR, HU, IE, IS, IT, LT, LU, LV, MC, MK, MT, NL, NO, PL, PT, RO, RS, SE, SI, SK, SM, TR), OAPI (BF, BJ, CF, CG, CI, CM, GA, GN, GQ, GW, ML, MR, NE, SN, TD, TG).
- Published:  
— with international search report (Art. 21(3))

(54) Title: TRANSCATHETER VALVE PROSTHESIS

FIG 1



(57) Abstract: A transcatheter atrio-ventricular valve prosthesis (1) for functional replacement of an atrio-ventricular heart valve in a connection channel (10), having a circumferential connection channel wall structure (25), between the atrial chamber (15) and the ventricular chamber (20) of a heart, comprising a radially expandable tubular body (30) to be disposed in the interior of the connection channel (10) and extending along an axis (35), and a valve (40) arranged within and attached to the tubular body (30), wherein the tubular body (30) is provided with an outer circumferential groove (45) which is open to the radial outside of the tubular body (30) and which defines a groove bottom (46), whereby the tubular body (30) is separated by the outer circumferential groove into first (31) and second (32) body sections, and wherein the tubular body (30) is provided with a first plurality of projections (50, 55) which extend from the first or second body section (31, 32) in an axial direction of the tubular body (30) and each of which has a free end (60, 65) arranged to overlap the outer circumferential groove (45), further comprising an elongate outer member (75) to be disposed at the exterior of the connection channel wall structure (25) at a level of the circumferential groove (45), wherein the outer member (75) can at least partially extend around the tubular body (30) with valve tissue of the connection channel wall structure (25) being correspondingly circumferentially arranged between the tubular body (30) and the outer member (75) and in such a radial distance (R5) to the axis (35) of the connection channel (10).

the tubular body (30) that the valve tissue of the connection channel wall structure (25) can be radially forced into the outer circumferential groove (45) so as to be at least partially located radially below the projections (50, 55).

## TRANSCATHETER VALVE PROSTHESIS

### Technical Field

[0001] Embodiments generally relate to a transcatheter valve prosthesis, especially a transcatheter atrio-ventricular valve prosthesis.

### Background

[0002] Heart valve diseases are affecting approximately 300.000 people worldwide each year. Those diseases translate in abnormal leaflet tissue (excess tissue growth, tissue degradation/rupture, tissue hardening/calcifying), or abnormal tissue position through the cardiac cycle (i.e. annular dilation, ventricular reshaping) leading to a degrading valve function like leakage/blood backflow (valve insufficiency) or a resistance to blood forward flow (valve stenosis).

[0003] Accordingly, a transcatheter valve prosthesis for functional replacement of a heart valve is desirable.

### Summary

[0004] Various embodiments of the invention provide a transcatheter atrio-ventricular valve prosthesis for functional replacement of an atrio-ventricular heart valve in a connection channel, having a circumferential connection channel wall structure, between the atrial chamber and the ventricular chamber of a heart, comprising a radially expandable tubular body to be disposed in the interior of the connection channel and extending along an axis, and a valve arranged within and attached to the tubular body, wherein the tubular body is provided with an outer circumferential groove which is open

to the radial outside of the tubular body and which defines a groove bottom, whereby the tubular body is separated by the outer circumferential groove into first and second body sections, and wherein the tubular body is provided with a first plurality of projections which extend from the first or second body section in an axial direction of the tubular body and each of which has a free end arranged to overlap the outer circumferential groove, further comprising an elongate outer member to be disposed at the exterior of the connection channel wall structure at a level of the circumferential groove, wherein the outer member can at least partially extend around the tubular body with valve tissue of the connection channel wall structure being correspondingly circumferentially arranged between the tubular body and the outer member and in such a radial distance to the axis of the tubular body that the valve tissue of the connection channel wall structure can be radially forced into the outer circumferential groove so as to be at least partially located radially below the projections.

[0005] Various embodiments of the invention further provide a method for implanting a transcatheter atrio-ventricular valve prosthesis comprising a tubular body having a longitudinal axis, a circumferential groove and a plurality of projections each having a free end arranged so as to partially overlap the groove, and an elongate outer member, the method comprising the steps of positioning the tubular body inside a connection channel between an atrial and a ventricular chamber of a heart, positioning the elongate outer member on an outside of the connection channel at an axial level of the circumferential groove, and fixating the prosthesis relative to the heart by reducing a distance between the elongate outer member and the tubular body so that tissue of the connection channel

is inserted into the groove so as to at least partially be radially inside the projections with respect to the axis.

### **Brief Description of the Drawings**

[0006] In the drawings, like reference characters generally refer to the same parts throughout the different views. The drawings are not necessarily to scale, emphasis instead generally being placed upon illustrating the principles of the invention. In the following description, various embodiments are described with reference to the following drawings, in which:

Figure 1 shows schematically a transcatheter valve prosthesis according to an embodiment located in a connection channel of a human heart,

Figure 1a shows a detail of a free end of a projection of the valve prosthesis according to a variation,

Figure 1b shows a detail of a free end of a projection of the valve prosthesis according to a variation,

Figure 2 shows a transcatheter valve prosthesis according to an embodiment,

Figure 2a schematically shows extension angles of projections according to an embodiment,

Figure 3 shows schematically a transcatheter valve prosthesis comprising an elongate outer member according to an embodiment located in a connection channel of a human heart,

Figure 4 shows a transcatheter valve prosthesis including a clamping member according to an embodiment,

Figure 5 shows the transcatheter valve prosthesis including the clamping member of Figure 4 from a different perspective,

Figure 6a shows a schematic cross section of a transcatheter valve prosthesis along A-A in Figure 3,

Figure 6b shows a schematic cross section of a transcatheter valve prosthesis along B-B in Figure 3,

Figure 6c shows a schematic cross section of a transcatheter valve prosthesis along C-C in Figure 4 including a clamping member,

Figure 6d shows a schematic cross section of a transcatheter valve prosthesis along C-C in Figure 4 including a clamping member in another arrangement than shown in Figure 6c.

Figure 7 schematically shows the interaction of a transcatheter valve prosthesis, heart tissue and an elongate outer member according to an embodiment,

Figure 8 shows a transcatheter valve prosthesis according to an embodiment,

Figure 9 shows a tubular body of a transcatheter valve prosthesis,

Figure 10 schematically shows the transcatheter valve prosthesis including an outer member, and

Figure 11 schematically shows the transcatheter valve prosthesis including an elongate outer member according to a variation.

### **Description**

[0007] The following detailed description refers to the accompanying drawings that show, by way of illustration, specific details and embodiments in which the invention

may be practiced. These embodiments are described in sufficient detail to enable those skilled in the art to practice the invention. Other embodiments may be utilized and structural, logical, and electrical changes may be made without departing from the scope of the invention. The various embodiments are not necessarily mutually exclusive, as some embodiments can be combined with one or more other embodiments to form new embodiments.

[0008] With reference to Figures 1, 1a, 1b and 2, a transcatheter atrio-ventricular valve prosthesis 1 for functional replacement of a (native) atrio-ventricular heart valve 5 in a connection channel 10 that connects an atrial heart chamber 15 with a ventricular chamber 20 and comprising a connection channel wall structure 25 may comprise a tubular body 30. The tubular body 30 may be disposed in the interior of the connection channel 10 and extend along an axis 35. The axis 35 may be the longitudinal axis 35 of the tubular body 30 which may be an elongated body. In the implanted condition, the axis 35 of the tubular body 30 may be aligned substantially coaxial to an axis of the connection channel 10. The tubular body 30 may be radially compressible so as to facilitate approach to and insertion into the connection channel 10, e.g. using a catheter or the like, and then be radially expandable so as to closely engage the interior or inner side of the connection channel wall structure 25, and may comprise an artificial heart valve 40 (e.g. schematically shown in Figure 6a) arranged within the tubular body 30.

[0009] The native atrio-ventricular heart valve 5 (e.g. a mitral valve or a tricuspid valve) to be replaced has the generally circumferential wall structure 25 forming the connection channel 10 or through opening between the atrial 15 and ventricular 20 chambers of the heart and including a circumferential valve annulus, valve leaflets opening and closing

the connection channel/through opening and closing the connection channel 10/through opening at a position close to the valve annulus, a generally circumferential cord structure (chordae tendinae) connected between the valve leaflets and generally circumferential papillary muscle(s), and said circumferential papillary muscle(s).

[0010] The artificial heart valve 40 may be attached to the tubular body 30 and may be designed to serve as an artificial replacement valve for an atrio-ventricular heart valve (for example a mitral and/or a tricuspid valve). The artificial valve 40 may comprise artificial flaps (e.g. three flaps as schematically shown in e.g. in Figure 6a) for functional replacement of the native heart valve. The tubular body 30 may be provided with an outer circumferential groove 45. The outer circumferential groove 45 may be open to the radial outside of the tubular body 30. The circumferential groove 45 may define a groove bottom 46. The outer circumferential groove 45 may define a channel 47 which is defined itself by the groove bottom 46 and axially (in axial direction of the tubular body 30) opposite side walls 48, 49. The groove bottom 46 may separate the tubular body 30 in first and second body sections 31, 32. The circumferential groove 45 may extend around a whole circumference of the tubular body 30 or may only extend partially around a circumference of the tubular body 30. The outer circumferential groove 45 may be a continuous that is non-interrupted groove, but may also be an interrupted groove 45 having, for example, two or more circumferential groove portions 45 provided, for example, on the same axial level of the tubular body 30 that are interrupted by areas in which no recessed portion, which may provide groove portion, is formed. The circumferential groove 45 may have an axial distance (along axis 35) from the axial ends

of the tubular body 30, i.e. the circumferential groove 45 may be formed spaced apart in an axial direction from end portions of the tubular body 30.

[0011] As shown in Figure 1, the first body section 31 may be the part of the tubular body 30 that is located above (e.g. proximal from) the circumferential groove 45, and the second body section 32 may be the part of the tubular body 30 that is located beneath (e.g. distal from) the circumferential groove 45. Both of the first and second body sections 31, 32 may have a generally cylindrical shape. According to a variation, the first body section 31 may have a conical shape along the axis of the tubular body, with its cross-section diameter increasing from the groove 45, and the second body section 32 may be generally cylindrical. According to a variation, both of the first and second body sections 31, 32 may have a conical shape along the axis of the tubular body, with their respective cross-sectional diameter increasing from the groove 45. According to variations, the cross sections (along axis 35) of sections 31 and/or 32 may be or contain non circular shapes but elliptical shapes or D-shaped cross sections. In addition, the direction of curvature in the axial profile (seen in a axial section along the tubular body 30) between the groove 45 and the first body section 31 and/or between the groove 45 and the second body section 32 may change (from concave curvature of the groove 45 to a convex curvature at the transition between groove 45 and first and/or second body section 31, 32). The axially opposite side walls 48, 49 of the groove 45 may be part of the first and second, respectively, body sections 31, 32 and may axially delimit the first and second, respectively, sections 31, 32 towards the channel 47 of the groove 45, as it is shown e.g. in Figure 8. A radial diameter of the first body section 31 (e.g. at an end portion that is opposite to the second body section 32) of the tubular body 30 may be



larger than any diameter of the second body section 32. This may allow to more efficiently fixate the prosthesis 1 in the connection channel 10 as the first body section 31 having a larger diameter may provide a better hold of the prosthesis 1 in the connection channel 10 by providing a friction and/or (mere) form fit (e.g. caused by the first body section 31 being located in the atrial chamber 15 and having a diameter larger than a diameter of the connection channel 10).

[0012] Further, the valve prosthesis 1 may comprise a first plurality of projections 50 and a second plurality of projections 55. The projections 50, 55 may extend from the first and second sections 31, 32, respectively, in opposite axial directions, that is they extend, at least with an extension component or an extension vector, in a direction along the axis 35 (e.g. the longitudinal axis 35) of the tubular body 30. Accordingly, the first projections 50 and the second projections 55 extend generally towards each other, whereby they may not extend exactly or in line towards each other, but with an extension vector. The projections 50, 55 may extend substantially parallel to the axis 35 of the tubular body 30 or may also extend in a (lateral) angle  $\gamma$  to the axis 35 of the tubular body 30, wherein the (lateral) angle  $\gamma$  extends tangential to the circumference of the tubular body 30, as it is shown e.g. in Figure 2a.

[0013] The valve prosthesis 1 may comprise one plurality of projections 50, 55 only that may extend from the first or second sections 31, 32 in an axial direction of the tubular body 30 and may overlap the circumferential groove 45. With reference to e.g. Figs. 11a-c, the valve prosthesis 1 may not comprise any projections 50, 55 and the circumferential groove 45 may be provided with (e.g. integrally formed on) the tubular body 30.

[0014] The projections of the first plurality of projections 50 each may have free ends 60, and the projections of the second plurality of projections 55 each may have free ends 65. The free ends 60, 65 of the first and the second plurality of projections 50, 55 may be arranged so as to overlap the outer circumferential groove 45. That is, the free ends of the first and second plurality of projections 50, 55 are arranged at an axial level of the groove 45 so as to overlap the groove 45. The first and second plurality of projections 50, 55 as such may at least partially or completely overlap the groove 45 along their extension.

[0015] The first 50 and second 55 pluralities of projections may extend in a radial distance radially outwards of the bottom 46 of the groove 45 so that a hollow (circumferential) chamber 66 is defined between the groove bottom 46 and the first and second plurality of projections 50, 55 in the channel 47. The opposite side walls 48, 49 may further define the hollow chamber 66 in axial direction of the tubular body 30. Hence, the hollow chamber 66 may be confined radially by the pluralities of projections 50, 55 and the groove bottom 46 and axially by opposite sidewalls 48, 49 (e.g. top- and bottom-walls) of the groove 45.

[0016] A method of using a transcatheter valve prosthesis 1 may comprise positioning it in the connection channel wall structure 25 of a heart and then inserting tissue that is adjacent to the circumferential groove 45, of the connection channel wall structure 25 into the circumferential groove 45 to be placed radially below the first and second plurality of projections 50, 55. The tissue can then be held in place in the circumferential groove 45 by the first 50 and/or second plurality of projections 55, which, if, for example, provided with acute or sharpened ends, may penetrate into the tissue which from its position below may be biased back to its initial radial position. The prosthesis 1 may be

positioned such that its outer circumferential groove 45 is at the level of the annulus of the circumferential wall structure 25 or adjacent thereto towards the side of the ventricular chamber 20. By the first and second plurality of projections 50, 55 keeping the tissue within the groove 45, the transcatheter valve prosthesis 1 can be positioned and fixated relative to the heart. Further, since the first and second plurality of projections 50, 55 axially extend towards each other, the prosthesis is further safely and reliably prevented from being axially pushed out of the connection channel 10 by the pumping activity of the heart. The first 50 and/or the second 55 plurality of projections may keep the tissue of the connection channel wall structure 25 in the circumferential groove 45 by perforating it (e.g. transfixing it, e.g. skewering it) and/or by an interference fit. The tissue that is held in the circumferential groove 45 may also (partially or fully) seal the transcatheter valve prosthesis 1 against the interior of the connection channel 10 so that blood, e.g. pressurized blood, can only flow through the tubular body 30 (and the artificial heart valve 40 therein) but can not bypass the tubular body 30 on its exterior side (i.e. between the exterior of the tubular body 30 and the interior of the connection channel wall structure 25). In this respect, the inner and/or outer circumferential surface of the tubular body 30 may additionally be provided with an impermeable layer, for example in form of a liner 33b.

[0017] The prosthesis 1 may be located in the connection channel 10 so that the circumferential groove 45 is located on the ventricular side of the annulus of a natural valve, e.g. having a distance from the natural valve annulus, i.e. the circumferential groove 45 may be a sub-annular circumferential groove and/or the prosthesis 1 may be a sub-annular-prosthesis 1. The prosthesis 1 may be adapted to be a sub-annular prosthesis.

That is, the tubular body 30 may have a transverse dimension (also referred to as diameter herein) at an axial level (with respect to axis 35) that is smaller than a transverse dimension of a natural valve annulus and/or transverse dimension and/or axial lengths of the tubular body may be suitable so that the first body section 31 may be located in an atrial chamber 15 and that the second body section 32 may be located in the connection channel 10 with the groove 45 being located on a ventricular side of the natural valve annulus having a distance to said annulus.

[0018] Only one circumferential groove 45 as described above may be provided on the tubular body 30. However, an elongated prosthesis 1 having two or more circumferential grooves 45 may be provided, wherein a respective set of first and a second plurality of projections 50, 55 as described above may be arranged and assigned to the respective one of the two or more grooves 45. The groove 45 or the respective groove may be formed by the first and second body sections 31, 32 of the tubular body 30 as such, wherein the projections 50 and/or 55 may not be involved in forming the (respective) groove 45 as such. There may also be embodiments (see further below), in which the projections 50 and/or 55 are at least partially in forming the groove 45, for example on the side of the tubular body 30 that is proximal to the ventricular chamber 20.

[0019] The tubular body 30 may comprise or may be a mesh-type body having elongate mesh or grid elements 33 crossing each other at crossings 34. The mesh elements 33 may be formed from wires comprising steel and/or a superalloy and/or a shape memory alloy (e.g. nitinol) and/or nickel and/or titanium and/or precious metals (e.g. gold) and/or alloys comprising the aforementioned. The mesh elements 33 may also comprise other alloys or may be made from organic material, e.g. polymers. The mesh elements 33 may e.g. be

made from polyvinyl-chloride and/or polystyrene and/or polypropylene or another polymer. The tubular body 30 may be from a shape-memory material which expands when experiencing usual body temperature. The tubular body 30 may be self-expandable. The tubular body 30 may also be not self-expandable, but expandable by a balloon or another expansion mechanism. Correspondingly, the tubular body 30 may be compressible to be insertable via the catheter and may then be expandable when appropriately positioned with the connection channel wall structure 25. The tubular body 30 may comprise the above-mentioned liner 33b (c.f. Figure 6a) attached to the mesh elements 33 made from the same or made from different materials. The liner 33b may be disposed on an interior side or an exterior side of the mesh elements 33 and/or tubular body 30 and may cover the circumference of the tubular body 30 fully or only partially in axial direction 35 and/or in circumferential direction.

[0020] The circumferential groove 45 of the tubular body 30 and/or the projections of the first and/or the second plurality of projections 50, 55 may interact with the connection channel wall structure 25 so as to fixate the valve prosthesis 1 with respect to the channel wall structure 25 and the connection channel 10. Tissue of the channel wall structure 25 may be "caught" in the circumferential groove 45 and be held in place by the free ends 60, 65 of the first and/or the second plurality of projections 50, 55 which may serve as hook elements. The tissue of the channel wall structure 25 may be perforated by the free ends 60, 65 and thereby held more firmly in the circumferential groove 45 of the tubular body 30, wherein the tissue may also be held in the groove 45 by means of an interference and/or clamping fit between the projections 50 and/or 55 (or part thereof) and the tissue of the connection channel wall structure 25. In order to allow the first

and/or second plurality of projections 50, 55 to penetrate the tissue of the circumferential connection channel wall structure 25, which has been forced into the groove, the free ends of a plurality or of each of the first 50 and/or second 55 pluralities of projections may be an acute or sharpened end. The projections of the first and/or second plurality of projections 50, 55 each or some thereof may be pins.

[0021] With further reference to Figure 1b, the free ends 60, 65 of the first and/or the second plurality of projections 50, 55 may be conical ends 70 so as to be able to perforate tissue of the connection channel wall structure 25. According to a variation, the free ends 60, 65 of the first and/or the second plurality of projections 50, 55 may also be blunt. The free ends 60, 65 and/or the first and/or second plurality of projections 50, 55 may be pin-shaped.

[0022] Some or all of the free ends 60, 65 of the projections 55, 60 may comprise barbs or hooks 71 as shown in Figure 1a. The hooks 71 may serve to perforate tissue of the connection channel wall structure 25 and prevent the tissue from slipping off the free end 60, 65. Thereby tissue that is perforated by barbs or hooks 71 disposed on a free end 60, 65 is unable to slip from the free end 55, 65 resulting in tissue from the heart valve connection channel wall structure 25 being caught even more reliably in the circumferential groove 45. Some or all of the free ends 60, 65 may be blunt or may have conical ends 70 or comprise barbs or hooks 71. The first 50 or second 55 plurality of projections may comprise different types of free ends 60, 65 according to the anatomical conditions, but may also comprise the same type of free ends 60, 65.

[0023] The free ends 60, 65 and/or the first 50 and second pluralities 55 of projections may be arranged in different axial and/or radial positions and orientations with respect to

each other. With reference to Figures 1 and 6a, each projection of the first plurality of projections 50 may have the same circumferential angular distance  $\alpha$  (that is an angular distance between two radial directions extending from longitudinal axis 35 of the tubular body 30) from each other, i.e. the projections 50 may be equally circumferentially spaced. However, the projections of the first plurality of projections 50 may also have different angular distances  $\alpha$  from each other, i.e. be not spaced evenly around a circumference of the tubular body. Although not shown in Figs. 6a-c, similarly, each projection of the second plurality of projections 55 may have the same angular distance from each other, i.e. be spaced equally around a circumference of the tubular body 30. However, the projections of the second plurality of projections 55 may also have different circumferential angular distances  $\alpha$  from each other, i.e. be not spaced evenly around a circumference of the tubular body.

[0024] The first plurality of projections 50 may be arranged with respect to the second plurality of projections 55 on the tubular body 30 in a way that each projection of the first plurality of projections 50 is substantially on the same radial level (that is the same radius, e.g. R2) as a projection of the second plurality of projections 55 (as it is shown e.g. in Figures 1 and 3). On the other hand, each projection of the first plurality of projections 50 may be arranged on a different radius than a projection of the second plurality of projections 55, wherein the first plurality of projections 50 may each be on a same radius, and wherein the second plurality of projections 55 may each be on a same radius.

[0025] With, for example, reference to Figures 1 and 3, the first plurality of projections 50 and the second plurality of projections 55 may extend so as to be aligned or coaxial to

each other. The first plurality of projections 50 may also not be aligned with the second plurality of projections 55, wherein the first plurality of projections 50 may themselves extend substantially parallel to each other or may not, and wherein the second plurality of projections 55 may themselves extend substantially parallel to each other or may not.

[0026] With, for example, reference to Figures 2 and 4, the first and second plurality of projections 50, 55 may be arranged in circumferential direction in an alternating manner, wherein for example each first projection 50 is circumferentially between two second projections 55 (and the other way round). There may also be other appropriate circumferential arrangement patterns for the first and second plurality of projections 50, 55, wherein, for example, sets of first projections 50, of for example one, two, three, four, or more first projections 50, are arranged between sets of second projections 55, of for example one, two, three, four or more second projections 50.

[0027] The number of the projections of the first plurality of projections 50 and the number of projections of the second plurality of projections 55 may be, for example, in a range of three to five, or eight to ten, fifteen to twenty, thirty to hundred or more or may be any other number. The first plurality of projections 50 may comprise the same number of projections or another number of projections as the second plurality of projections 55 or vice versa.

[0028] The projections of the first plurality of projections 50 and/or the projections of the second plurality of projections 55 may extend from the tubular body 30 from positions, where mesh elements 33 of the tubular body 30 are crossing with each other at the crossings 34. This may improve the mechanical stability of the interconnection of the tubular body 30 with the projections 50, 55. The projections 50, 55 may e.g. be welded,



soldered and/or braided to the tubular body 35. They may also be sutured, bonded or glued to the tubular body 35. As an alternative or additionally, the projections 50, 55 may also be monolithically integrally formed with the tubular body 30. That is, with reference to e.g. Figs. 9a and 9b, the projections 50,55 (or any one or both of the pluralities of projections) may be formed by mesh elements 33 that are not connected to another mesh element 33 at a crossing 34 but are projecting from the tubular body 30 (e.g. caused by bending the mesh element 33) in a radial and/or axial direction with respect to longitudinal axis 35 so as to form a projection 50, 55. Further, projections 50, 55 (e.g. monolithically integrally formed by mesh elements 33 or provided separately and connected with the tubular body 30) may form the circumferential groove 45 by projecting radially and axially from the tubular body 30 with respect to its longitudinal axis 35. Accordingly, by facing away from the tubular body 30, the projections may define a circumferential groove 45 on the tubular body 30. The circumferential groove 45 may also be further defined by a generally conical or similar shape of a body section (e.g. first body section 31 and/or second body section 32) of the tubular body 30 that has a crosssectional diameter that is increasing from the groove 45 in a direction of longitudinal axis 35. As seen e.g. in Figs. 9a and 9b, the generally conical shape of a body section 31, 32 may accordingly interact with the projections 50, 55 which are projecting from the tubular body 30 so as to further define the circumferential groove 45. Fig. 9a shows projections 50, 55 that define a circumferential groove 45 by projecting first in a substantially radial direction relative to the longitudinal axis 35 and then in a substantially parallel direction to the longitudinal axis 35 when seen from the point from which the projections extend from tubular body 30. Fig. 9b shows projections 50, 55 that

extend generally rectilinearly to define the circumferential groove 45. The projections 50, 55 may be made from the same materials that were described above with reference to the tubular body 30, e.g. super alloys, e.g. shape memory alloys (like nitinol) or steel or titanium (or alloys comprising titanium) or organic material like polymers, or the projections may be made from different material or materials.

[0029] As can be seen e.g. from Figure 8, all or some projections of the first plurality of projections 50 and/or all or some projections of the second plurality of projections 55 may be extending in (e.g. along) a substantially straight line or in a straight line, i.e. they may not comprise any longitudinal curvature from the point from which they extend from the tubular body 30 to their respective free end 60, 65, i.e. they may extend rectilinearly. They may, however, nevertheless comprise barbs or hooks 71 and/or may be pin-shaped. The first plurality of projections 50 may extend from substantially the same axial level (relating to the axial direction of the tubular body 30) from the tubular body 30 (e.g. shown in Figure 1 to 3) or may extend from different axial levels from the tubular body 30. Correspondingly, the second plurality of projections 55 may extend from substantially the same axial level (relating to the axial direction of the tubular body 30) from the tubular body 30 (e.g. shown in Figure 1 to 3) or may extend from different axial levels from the tubular body 30. The axial extension of the first plurality of projections 50 (axial distance (along axis 35 of tubular body 30) between base of projection on the tubular body and free end of projection) and/or of the second plurality of projections 55 may be substantially the same or may be different, and the extension or length of the first plurality of projections 50 and/or of the second plurality of projections 55 (distance

between basis of the projection 50, 55 on the tubular body 30 and the free end 60, 65 of the projection 50, 55) may be the same or may be different.

[0030] In addition to the first and second plurality of projections 50, 55 the tubular body 30 may be provided with any other type of projection and/or collar.

[0031] The first 50 and the second plurality 55 of projections may extend from the first 31 and the second 32 body sections, respectively, from areas that are adjacent to or are bordering the radial outer circumference of the circumferential groove 45. The first 50 and the second plurality 55 of projections may extend from the opposite side walls 48, 49 laterally defining the groove 45.

[0032] Referring to Figure 2, the free ends 60 of the first 50 plurality of projections may be axially spaced from the free ends 65 of the second 55 plurality of projections by an axial distance W2 in a direction of the axis 35 of the tubular body 30. The free ends 60 of first plurality of projections 50 may be arranged on a same axial level or on different axial levels, and the free ends 65 of the second plurality of projections 55 may be arranged on a same axial level or on different axial levels.

[0033] In case a transcatheter valve prosthesis 1 comprises one plurality of projections 50, 55, the axial distance W2 may define a distance of one or more or all of the free ends 60, 65 of the (one) plurality of projections 50, 55 to a sidewall 48, 49, that is opposite to the respective body section 31, 32 the plurality of projections is extending from, of the circumferential groove 45.

[0034] The projections of the first plurality of projections 50 may axially overlap with the projections of the second plurality 55 of projections with each other (not shown), wherein there may be defined an axial overlapping-distance between the free ends 60 of

the first plurality of projections 50 and the free ends 65 of the second plurality of projections 55. Some free ends 60 of the first plurality of projections 50 may be axially spaced from corresponding free ends 65 of the second plurality of projections 55, while other free ends 60 and 65 may be arranged so as to axially overlap each other.

[0035] With reference, for example, to Figure 2a, the projections 50, 55 (each) may extend in a manner so as to be radially and inwardly inclined by an angle  $\beta$ , thereby obliquely extending into the outer circumferential groove 45. The angle  $\beta$  defining the radial and inward inclination of the projections 50, 55 with respect to the axis 35 of the tubular body 30 may be an acute angle, for example in a range of equal or smaller than  $45^\circ$  or equal or smaller than  $30^\circ$ , or equal or smaller than  $15^\circ$ . Only a part or number of the first projections 50 and/or only a part or number of the second projections 55 may radially and inwardly inclined as above described.

[0036] Figure 6a, which corresponds to the cross section along A-A shown in Figure 3, illustrates the interaction of heart valve tissue of the connection channel wall structure 25 and the first plurality of projections 50 (a cross-section transverse the axis 35 and through the second plurality of projections 55 would result in a similar depiction as shown in figure 6a). The first plurality of projections 50 can be seen perforating tissue of the connection channel wall structure 25 to thereby more reliably prevent it from retracting from the tubular body 30 of the prosthesis 1, which results in the prosthesis 1 being held more firmly in its intended place.

[0037] With further reference to Figure 3 and Figure 6b, the transcatheter atrio-ventricular valve prosthesis 1 may further comprise an elongate outer member 75. The elongate outer member 75 may be disposed at the exterior of the connection channel wall

structure 25 (i.e. e.g. in the ventricular chamber 20) at an axial level (e.g. with respect to axis 35) of the circumferential groove 45 of the tubular body 30. The elongate outer member 75 may extend at least partially around, for example completely and continuously circumferentially around, the tubular body 30 and may be handled e.g. using a catheter member 90 that is shown schematically in Figure 6b. A radial distance R5 between the longitudinal axis 35 and the elongate outer member 75 may be reducible or reduced so that the valve tissue of the connection channel wall structure 25 can be correspondingly at least partially forced into the outer circumferential groove 45 so as to be at least partially located radially below the first and second plurality of projections 50, 55. The radial distance R5 may be reducible or reduced so that it is smaller than a radial distance R4 that is defined between the longitudinal axis 35 of the tubular body 30 and the free ends 60, 65 of the projections 50, 55 (the free ends 60, 65 are not visible in the cross section shown in Figure 6b, but they are indicated by crosses in Fig. 6b). This means, that the elongate outer member 75 may be positioned inside the circumference defined by the first and the second plurality of projections 50, 55 so that tissue of the connection channel wall structure 25 is or can be located in the circumferential groove 45 between the groove bottom 46 and the first and second projections 50, 55, wherein the elongate outer member 75 itself may be located inside the groove 45 between the groove bottom 46 and the first and second plurality of projections 50, 55. However, the elongate outer member 75 may also be arranged to force tissue of the connection channel wall structure 25 into the circumferential groove 45 but to remain outside the groove (i.e. R5 may be larger than R4 as it is shown in Figure 6b). The catheter member 90, or an other, for example similarly structured catheter device, may be used to handle and position the

elongate outer member 75 around an exterior of the circumferential connection channel wall structure 25.

[0038] With further reference to Figures 6b and 7, the catheter member 90 may comprise a connecting means 91, for example a cutting and clamping means, that can be used to connect free ends of the elongate member 75, for example to cut the elongate outer member 75 and clamp two ends of it together, so that the elongate member 75 may remain permanently around the tubular body 30 and thereby forms a component of the prosthesis 1. However, the elongate outer member 75 may also merely be an interventional tool, for example as a component of catheter member, and may only be used to radially force the tissue of the connection channel wall structure 25 into the outer groove 45, and may then be withdrawn or removed from the heart. When the elongate member 75 remains permanently positioned around an outer side of the connection channel wall structure 25, it may permanently apply a radial and inwardly directed force to the tissue of the connection channel wall structure 25 towards the groove 45.

[0039] With reference to Figures 1, 3, 6b and 7 there may be several ways in which heart tissue of the connection channel wall structure 25 is fixated, held and/or caught in the circumferential groove 45. The tissue may be perforated by the free ends 60, 65 of the first and/or the second plurality of projections 50, 55 e.g. via the acute ends 70 and/or the barbs or hooks 71. The tissue may also be held in the circumferential groove 45 by an interference fit between the projections 50, 55. The tissue may also be held in the circumferential groove 45 by the elongate outer member 75. The elongate outer member 75 may be used to force the tissue into the groove 45 either temporarily (e.g. as a method step during a heart treatment) or permanently (for example, if the cutting and clamping

means 91 is used to cut elongate outer member 75 and to connect its two ends together permanently while it is extending around the exterior of the connection channel wall structure 25 as shown in Figure 7). The tissue of the connection channel wall structure 25 may also be held in the circumferential groove 45 by a combination of two or more of the above described means and effects.

**[0040]** In all embodiments, the elongate outer member 75 may have a cross-sectional diameter  $D1$  (see e.g. Figure 6b) that is smaller than a width  $W1$  of the outer circumferential groove 45 (illustrated e.g. in Fig. 2). The elongate member 75 may also have a cross-sectional diameter  $D1$  that is smaller than the gap  $W2$  between the free ends 60, 65 of the first and the second plurality of projections 50, 55. The elongate member 75 may have a cross-sectional diameter  $D1$  that is larger than width  $W2$  but smaller than width  $W1$ . The elongate member 75 may have a cross-sectional diameter  $D1$  that is larger than width  $W2$  and/or width  $W1$ . The elongate member 75 may be a wire or a band, and may have a circular cross section or a rectangular cross section. The elongate member 75 may also have a triangular cross section or a cross section defining any other shape. The elongate member 75 may be made from any material that has been described with reference to the mesh elements 33 or a combination of those materials or other material(s). For example, the elongate member may be made from steel, a titanium alloy or a shape memory alloy such as nitinol.

**[0041]** Further, a length of the projections 50 and/or 55 may be related to the width  $W1$  of the circumferential groove 45. In this respect, the ratio of a distance between the free ends 60, 65 of the first and second pluralities of projections 50, 55 (or, if only one plurality of projections 50, 55 is provided, a distance of the free ends 60, 65 of that

plurality of projections 50, 55 to the sidewall 48, 49 of the circumferential groove 45 that is with respect to axis 35 opposite to the projections 50, 55) to the width W1 of the circumferential groove 45 may have a maximum value of 0.5 or 0.4 or 0.3 or 0.2 or 0.1. Accordingly the hollow chamber 66 may be defined between the projections 50, 55 and the groove bottom 46. The width W1 of the circumferential groove 45 may be defined between the sidewalls 48, 49 of the groove 45 and/or between a point from which a projection 50, 55 of the first and/or second plurality of projections 50, 55 extends from the tubular body 30 and a sidewall 48, 49 that is located on an opposite side of the groove (45) and/or between a point from which a projection from the first plurality of projections 50 extends and a point from which a projection from the second plurality of projections 55 extends.

[0042] With reference to Figures 4 and 5 (for improved clarity and understanding, the transcatheter valve prosthesis 1 is shown without artificial valve 40), the transcatheter valve prosthesis 1 may also comprise a clamping member 80. The clamping member 80 may comprise a tubular structure having a longitudinal axis that may be arranged so as to extend in the circumferential groove 45 in a circumferential direction of the tubular body 30. The clamping member 80 may be located in the circumferential groove 45 so as to be located (for example at least partly) radially inwards of the first and second pluralities 50, 55 of projections. The clamping member 80 may be in contact with the groove bottom 46 of the circumferential groove 45. The clamping member 80 may extend around a whole circumference of the tubular body 30 or only partially around the tubular body 30, as shown e.g. in Figures 4 and 5. The clamping member 80 may extend e.g. around an angle of 10 to 30 degrees or any other angle in the circumferential groove 45. The clamping



member 80 may also extend around the whole circumference of groove 45, e.g. around 360 degrees. The clamping member 80 may have a crosssectional diameter D2 transverse to its longitudinal axis. The crosssectional diameter D2 may be selectively changeable to a larger or smaller diameter D2, i.e. the clamping member 80 may be compressible (so as to be insertable via a catheter) and/or expandable (for example, re-expandable after being compressed) in a radial direction of its diameter D2, whereby the inner and outer circumferences of the clamping member are correspondingly decreased/expanded and expanded/decreased, respectively, in a radial direction of the tubular body 30 towards the first and/or the second plurality of projections 50, 55. The cross sectional diameter D2 of the clamping member 80 may be smaller than the cross sectional diameter (radius R1 is shown e.g. in Figure 6a) of the tubular body 30. The clamping member 80 may be provided in order to clamp heart tissue that is located inside the circumferential groove 45 outwards in a direction from the axis 35 towards the pluralities of projections 50, 55.

[0043] With reference to Figure 6d, the clamping member 80 may also be or form part of the above described elongate outer member 75, wherein the clamping member 80 may then be arranged and/or guided and/or positioned (in a radially compressed condition) at the circumferential outer side of the connection channel wall structure 25 to completely or partly extend around the connection channel wall structure 25 at an axial (with respect to the axis 35 of the tubular body 30) level, and may then be radially expanded (in a direction of the diameter D2 of the clamping member 80), whereby its inner diameter in a radial direction of the tubular member 30 then correspondingly decreases to thereby force the tissue of the inwardly arranged connection channel wall structure 25 (which is then arranged inwards of the clamping member 80) radially into the groove 45. That is, the

clamping member may be located between the projections 50, 55 and tissue of the connection channel wall structure 25, that may be pressed into the groove 45 by an elastic force exerted by the clamping member 80 on the tissue of the connection channel wall structure 25 and a corresponding reactive force that may be exerted by the clamping member 80 on the projections 50, 55. The forces that may act upon the tissue of the connection channel wall structure 25 exerted by the clamping member 80 and the groove 45 (e.g. the groove bottom 46) are schematically indicated by arrows 85b. The elongate outer member 75 and/or the clamping member 80 (which may be the same member) may serve to anchor the prosthesis 1 and to seal the native heart leaflets against the prosthesis 1 against blood flow. Further, immobilization of the native leaflets by the prosthesis 1 as described herein (e.g. comprising a clamping member 80 and/or elongate member 75) may favour the ingrowth of heart (e.g. leaflet) tissue into the prosthesis (e.g. circumferential groove 45) and thereby further improve fixation of the prosthesis 1 relative to the heart and/or sealing against blood flow as the ingrown tissue may additionally or alternatively seal against blood flow on an outside of the tubular body 30.

[0044] Figure 6c shows a schematic cross sectional view of the tubular body 30 and the clamping member 80 similar to the cross section C-C in Figure 4, however additionally showing heart tissue of the connection channel wall structure 25 that is not shown in Figure 4. In Figure 6c, the positions of the first or second pluralities of projections 50, 55 are indicated by dots 50, 55. As can be seen from Figure 6c, the heart tissue of the connection channel wall structure 25 is located inside the circumferential groove 45 radially between the groove bottom 46 of the tubular body 30 and a diameter that is defined by the free ends 60, 65 of the first and/or the second plurality of projections 50,

55. It can be seen from Figure 6c that the clamping member 80 is elastically strained by the tissue of the connection channel wall structure 25 and in turn exerts a force that presses the tissue of the connection channel wall structure 25 against the free ends 60, 65. Arrows 85 indicate the forces that are caused by the clamping member 80 and that act upon the tissue of the connection channel wall structure 25 in the groove 45.

[0045] With reference e.g. to Figures 6c and 6d, which show only one clamping member 80, there may also e.g. be two or more clamping members 80 arranged in the groove 45 which are arranged in parallel to each other and/or which are arranged sequentially in a circumferential direction, with for example a circumferential distance therebetween or abutting each other, of the tubular body 30. For example, there may be two clamping members 80 abutting each other and a third clamping member 80 that has an angular distance from the two clamping members 80 that are abutting each other may also be arranged in the groove 45. Clamping members 80 may e.g. be positioned on diametrically opposite sides of the groove 45. These two or more (e.g. 3 to 5) clamping members 80 may all have the same crosssectional diameter  $D_2$  or may each have different crosssectional diameters. The clamping members 80 may all have the same longitudinal length or may have different longitudinal lengths (e.g. in a circumferential direction of tubular body 30). Clamping members 80 may be designed and arranged so that the tubular body 30 is firmly held in place according to the specific tissue structure and conditions of the connection channel wall structure 25 of a specific heart (e.g. of a patient). They may e.g. be specifically chosen and arranged by an operator or surgeon to firmly hold the tubular body 30 in place according to local conditions. The respective

clamping member 80 may have an other shape than a tubular, such as a block-shape, a cubic-shape or a ball-shape.

[0046] The force acting on the tissue of the connection channel wall structure 25 may be increased when the clamping member 80 is used together with the elongate outer member 75 thereby further improving the connection between the transcatheter valve prosthesis 1 and the connection channel wall structure 25. In this case, an elastic force origination from the clamping member 80 pointing from the axis 35 outwards and a force originating from the elongate outer member 75 pointing inwards to the axis 35 act upon tissue of the connection channel wall structure 25, thereby holding the prosthesis 1 firmly in its intended position in the connection channel 10. However, the valve prosthesis 1 may be used without the clamping member 80 and the elongate outer member 75 as well (i.e. by itself) or together with only one (anyone) of them. A prosthesis 1 not comprising a plurality of projections 50, 55 may be fixated by clamping member 80 and/or elongate outer member 75, e.g. when the elongate outer member 75 and/or the clamping member 80 are/is generally rigid, e.g. when comprising or being an inflatable balloon that is filled with a substance giving it rigidity caused by a pressure or by a curing of that substance. That substance can cure with a limited amount of time, with the injection of an additional agent (eg a reticulating agent), with application of heat or energy. It can be PMMA (Poly Methyl Methacrylate), different epoxies, polyurethane, a blend of polyurethane silicone. It can be strengthened with the addition of reinforcement fibers (eg Kevlar, carbon).

[0047] Clamping member 80 may be made from a mesh-type structure as shown in Figures 4 and 5 and may comprise an inner lumen. The mesh may be made from metal or organic material or other material. The mesh of clamping member 80 may be made e.g.

from iron, nickel, aluminium and/or titanium and/or alloys of these metals and other elements. The mesh may be made e.g. from steel (e.g. spring steel), and/or an superalloy and/or shape memory alloy (such as e.g. nitinol), Ti 6Al 4V, and/or a precious metal like gold or any combination of those and/or other materials. The mesh of clamping member 80 may also be made from polymers, e.g. from polypropylene or polyvinylchloride, Polyethylene or Nylon. Of course, the mesh may also be made from combinations of these materials, i.e. it may be made from two or more different materials. In one embodiment, the clamping member can be an expandable stent-graft made with a steel or nitinol stent covered with a Dacron or ePTFE graft. The mesh of clamping member may also or additionally comprise any material that has been described with reference to the mesh elements 33 of the tubular body 30 and/or with reference to the elongate member 75 and the clamping member 80 may be designed and a material for it may be chosen so as to create a high elastic force to press the tissue of the connection channel wall structure 25 against the projections 50, 55. Clamping member 80 may also be provided with hooks or barbs to create an attachment to tubular body 30.

[0048] Clamping member 80 and/or elongate outer member 75 may also comprise an inflatable inner member (not shown). The inflatable inner member may be disposed in an inner lumen of the clamping member 80 and may be inflated so as to increase diameter D2 of clamping member 80 thereby pressing tissue of the connection channel wall structure 25 against the projections 50, 55 (either from an inner side if the clamping member 80 is arranged in the hollow chamber 66 or from an outer side if the clamping member 80 is initially arranged at an outer side of the connection channel wall structure 25). The inner member may be inflated by the operator using a tubing and fluid from an

external pressure source, e.g. a syringe, a fluid bottle or a pump located outside the body. The clamping member 80 may also be an inflatable member 80 that presses tissue of the connection channel wall structure 25 against the projections 55, 55 when inflated. Both the inflatable inner member and the inflatable member 80 may be made from a fluid tight, pressure resistant material, e.g. a material or polymer as described above with reference to the clamping member 80 or any other suitable material. With reference to e.g. Fig. 11, the inflatable member may comprise an aperture 76 (e.g. a valve, e.g. an opening) through which a substance (e.g. via a delivery tube (not shown)) may be delivered into the inflatable member or out of the inflatable member. The aperture 76 may be selectively permitting the transmission of a substance (i.e. have an "open-state") or may be blocking the transmission of a substance (i.e. have a "closed-state"). The aperture 76 may serve to fill the inflatable member or to un-fill (e.g. to empty) the inflatable member in order to change a crosssectional diameter of the inflatable member. The clamping member 80 and/or the elongate outer member 75 may be made of an elastic material (e.g. a polymer and/or a metal) and/or may be filled with an compressible (e.g. elastical) substance (e.g. a gas and/or a foam material and/or a hydrogel) to provide a damping/cushioning functionality. A substance for filling the inflatable member may be a gas, a liquid or any other substance and/or may be a substance that changes its phase (e.g. gas, liquid, solid) when in the inflatable member (the substance may e.g. change from liquid phase to a generally solid phase). The substance may be a substance that is capable of curing and/or hardening when disposed in the inflatable member so as to provide a generally rigid clamping member 80 and/or elongate outer member 75.

[0049] Clamping member 80 may apply a force to the opposite side walls 48, 49 of groove 45, for instance upon radial expansion relatively to its longitudinal axis. This force may increase or decrease the distance between body sections 31 and 32 and/or the distance between axial ends (with respect to axis 35) of the tubular body 30. Tubular body 30 may be made to be elastic (e.g. comprising a mesh structure and/or an elastic material). The force exerted by clamping member 80 may also result in a expansion or reduction of a perimeter of the groove bottom 46 along a circumference of groove 45 and/or in an expansion or reduction of diameter R1 of the tubular body 30 at an axial height (with respect to axis 35) of groove 45 respectively. The clamping member 80 and/or the elongate outer member 75 (which may be the same member or may be separate members) may also not produce a force in a radial direction and/or a longitudinal direction of the tubular body 30 with respect to its longitudinal axis 35. Accordingly, the clamping member 80 and/or the elongate outer member 75 may act as a displacement member by displacing tissue of the connection channel 10 without exerting a clamping force to the tubular body 30 but by providing a mere interference fit between the circumferential wall structure 25 of the connection channel 10, the clamping member 80 and/or the tubular body 30 in addition or as alternative to e.g. tissue being pierced by projections of the first 50 and/or second plurality of projections 55.

[0050] The clamping member 80 and/or elongate outer member 75 may be located only partially radially inwards of the first 50 and/or second 55 plurality of projections and may be located so as to be pierced by anyone or both pluralities of projections so as to be held relative to the tubular body 30. The elongate outer member 75 and/or clamping member 80 may be pierced by only one plurality of projections 50, 55 and the other plurality of

projections may not pierce the clamping member 80/elongate outer member 75 (or, the other plurality of projections may not be provided in case of a prosthesis 1 only comprising one (a) plurality of projections (on one side of the groove 45)). The plurality of projections 50 and/or 55 may be piercing the clamping member 80 so that the respective free ends 60, 65 of the projections 50, 55 end inside the clamping member 80 or so that the free ends 60, 65 of the respective projections 50, 55 are penetrating through the clamping member 80 and exit from the clamping member so that the respective free ends 60, 65 may be located outside the clamping member 80.

[0051] With reference to Fig. 10b, the elongate outer member 75 and/or the clamping member 80 may also be provided in the groove 45 radially inwards of the projections 50, 55 so that the elongate outer member 75 and/or the clamping member 80 is not pierced by the projections 50, 55. The elongate outer member 75/clamping member 80 may be held by a mere interference fit or a frictional/interference fit between the groove 45, the tissue of the connection channel wall structure 25 and/or projections 50, 55 in the groove 45 (e.g. when inflated, e.g. when expanded). Further, as schematically shown in Fig. 10b, the elongate outer member 75/clamping member 80 may have a cross sectional shape that is substantially elliptical or has any other shape, such as a triangular, rectangular or polygonal shape. The substantially elliptical shape of the elongate outer member 75/clamping member 80 that is shown in Fig. 10b may be caused by the design of the elongate outer member 75/clamping member 80, e.g. when it is provided with a tubular structure having a substantially elliptical shape (e.g. when expanded), or it may be caused by anisotropic forces acting upon elongate outer member 75/clamping member 80 caused e.g. by the projections 50, 55, the tissue of the circumferential wall structure 25 and/or



groove 45. That is, the elongate outer member 75/clamping member 80 may have a substantially round cross section when no external forces act upon it and may be assuming a different shape (e.g. elliptical), when implanted (and, e.g. expanded).

[0052] With reference to e.g. Fig. 10c, an expandable and/or reducible elongate outer member 75 (e.g. clamping member 80) may have a diameter D2 that may be larger than width W1 of circumferential groove 45 when expanded so that the elongate outer member 75 may extend out of the groove 45 and may occupy a space between the circumferential wall structure 25 and tissue forming a heart chamber (e.g. the ventricular chamber 20 and/or atrial chamber 15), i.e. the elongate outer member 75 may form a shape arranged between (e.g. abutting) the connection channel wall structure 25 and tissue/muscles of a heart chamber wall (e.g. of ventricular chamber 20) when expanded (e.g. fully expanded). Accordingly, the elongate outer member 75 may be located (e.g. partially, e.g. a part thereof) radially outside (with respect to axis 35) the circumferential groove 45 and may extend parallel to axis 35 along one or both body sections 31, 32 (e.g. along second body section 32) of tubular body 30 while being (e.g. partially, e.g. a part of elongate outer member 75) located radially outside groove (45). Accordingly, the elongate member 75 may comprise an angularly shaped (e.g. substantially describing an angle of about 90°) cross section with a first angular leg 75a that may be extending with respect to axis 35 generally radially into the groove 45, and a second angular leg 75b that may be extending generally parallel to axis 35 of the tubular body 30 on an outside of the tubular body 30 (e.g. along first body section 31 and/or second body section 32). That is, the elongate outer member 75 (e.g. second angular leg 75b thereof) may be disposed between the first 31 and/or second 32 body section and tissue/muscle forming a wall of a

heart chamber such as the ventricular chamber 20 and/or atrial chamber 15. While in Fig. 10a-c the elongate outer member 75/clamping member 80 is only shown on one side of the prosthesis 1, it may also extend fully or partially (as shown e.g. in Fig. 11a-d) around the prosthesis 1 (e.g. the circumferential groove 45). The elongate outer member 75/clamping member 80 may comprise free ends 77, 78 (e.g. two free ends 77, 78) in a direction of a central-longitudinal axis that may be non-connected and/or not abutting each other, i.e. spaced away from each other. The free ends 77, 78 may have an angular distance from each other (e.g. in the groove 45, e.g. when inflated in the groove 45) defined by an angle of e.g. less than  $180^\circ$ , less than  $90^\circ$ , less than  $45^\circ$  or less than  $10^\circ$  with respect to axis 35. The aperture 76 may be provided on one of these free ends 77, 78 or an aperture 76 may be provided on each of the free ends 77, 78. When the elongate outer member 75/clamping member 80 only extends partially around circumferential groove 45 and accordingly comprises free ends, it may have a rigidity caused by a substance, e.g. by a curing substance (that may be cured).

[0053] Accordingly, the clamping member 80/elongate outer member 75 (e.g. when it comprises an elastic and/or compressible material, e.g. as described above) may serve to dampen movement of the heart (e.g. caused by the beating heart, e.g. pulse) by acting as a dampening and/or cushioning member between the heart (e.g. a heart chamber) and the prosthesis 1 (e.g. tubular body 30) to further improve the fixation of the prosthesis 1 relative in the heart by reducing forces caused by the beating heart acting on the prosthesis 1 by dampening these forces. Accordingly, the clamping member 80/elongate outer member 75 may absorb movements (e.g. of the ventricular wall (e.g. of the papillary muscle of the ventricular chamber 20) to avoid pulsation of the prosthesis 1.

The clamping member 80 may serve to maintain a distance of the prosthesis 1 from tissue of the heart (e.g. from a wall of the ventricular chamber 20 and/or the atrial chamber 15) and thereby improve placement and/or fixation of the prosthesis 1. Accordingly, the elongate outer member 75 and/or the clamping member 80 may serve as a damping member and/or a spacer member. The clamping member 80 and/or the elongate outer member 75 and hence, the groove 45, may be arranged on a side of the ventricular chamber when seen from the annulus of the natural valve having a distance from the annulus.

[0054] The shape of a cross section of tubular body 30 across its longitudinal axis (e.g. axis 35) may be modified. Catheter member 90 may comprise or provide a piercing component that can be positioned through the connection channel wall structure 25 (e.g. from an outside of connection channel wall structure 25) and through the tubular body 30 in substantially diametrically positions relatively to an axial (with respect to axis 35) cross section. The piercing component may be hollow and enable placement of an anchor on connection channel wall structure 25 at the distal position of a diameter of the connection channel wall structure 25 relatively to catheter member 90. Said anchor may be attached to a longitudinal end of a longitudinal component (e.g. a tether) which in turn may be provided with a second anchor on its other longitudinal end. The second anchor may be placed by the piercing component upon retrieval of the piercing component from the connection channel wall structure 25 at the proximal end (relatively to catheter member 90) of said diameter on connection channel wall structure 25. The length of said longitudinal component can be designed to be under tension from forces acting on the longitudinal component induced by the first and second anchors, so as to create a

deformation of tubular body 30 in a substantially elliptical shape, e.g. the longitudinal component may be shorter than a diameter of the tubular body 30 when no external forces act upon tubular body 30. The longitudinal component may be placed across an inner lumen of tubular body 30 in a position where it does not interfere with the function of valve 40, e.g. be geometrically spaced away from the valve 40. It may also be small enough to avoid significant interference with blood flow through tubular body 30, e.g. may have a radius or a diameter ranging from 100  $\mu\text{m}$  to 1000  $\mu\text{m}$ .

[0055] All embodiments of the transcatheter valve prosthesis 1 may comprise positioning and/or orientation devices to facilitate relative and/or absolute positioning of the tubular body 30 and/or the elongate outer member 75 and/or the clamping member 80. These devices may include passive markers that are fixedly attached to the tubular body 30 and/or the elongate outer member 75 and/or the clamping member 80. The passive markers may be made from materials different from the materials of the tubular body 30 and/or the elongate outer member 75 and/or the clamping member 80 in order to improve contrast during medical imaging, e.g. using magnetic resonance or X-ray based imaging techniques. The passive markers may e.g. be made of highly radio-opaque materials thereby allowing to precisely acquire the relative and/or absolute position of the components of the transcatheter valve prosthesis 1 with respect to the body. The passive markers may each have an asymmetrical shape so as to allow identifying the absolute and/or relative position and orientation and thereby the position and orientation of the tubular body 30 and/or the elongate outer member 75 and/or the clamping member 80. The passive markers may also have an identical shape and may be arranged in a certain configuration relative to each other to allow recognition of the orientation. The

circumferential groove 45 of the tubular body 30 and/or the tubular body 30 and/or the elongate outer member 75 and/or the clamping member 80 may have passive markers fixedly attached to facilitate positioning them relative to each other using imaging techniques, e.g. passive markers made of highly radio-opaque materials when imaging techniques based on electro-magnetic radiation (e.g. X-ray imaging) are used. In addition and/or as an alternative, the circumferential groove 45 and/or other parts/components of the tubular body 30 and/or the elongate outer member 75 and/or the clamping member 80 may be made from radio-opaque materials.

[0056] A method for using a transcatheter prosthesis 1 as described above may comprise:

[0057] - Placing the transcatheter valve prosthesis 1 within an atrio-ventricular valve, e.g. in a mitral or a tricuspid valve of a human or animal heart, via an insertion catheter. The transcatheter valve prosthesis 1 may e.g. be placed in a connection channel wall structure 25 between a ventricular chamber 20 and an atrial chamber 15 as shown in Figure 1.

[0058] To place transcatheter valve prosthesis 1 within the heart valve, the following approaches may be applied: 1) an arterial retrograde approach entering the heart cavity over the aorta, 2) through a venous access and through a puncture through the inter atrial septum (trans-septal approach), 3) over a puncture through the apex of the heart (trans-apical approach), 4) over a puncture through the atrial wall from outside the heart, 5) arterial access (e.g. the femoral artery through a puncture in the groin) or 6) any other approach known to a skilled person. The approach to the valve is facilitated as the tubular body 30 is radially compressible and extendable and may e.g. be folded and stuffed in a catheter during approach and may be unfolded/extended when being within the circumferential connection channel wall structure 25. The transcatheter valve prosthesis 1

may include the clamping member 80 or the clamping member 80 may be inserted separately via one of the mentioned approaches (e.g. using a catheter) so as to be placed in the circumferential groove 45 of the tubular body 30 when the tubular body 30 is located in the connection channel wall structure 25. The clamping member 80 may be compressible and expandable.

[0059] -Fixating the transcatheter valve prosthesis 1 in the heart relative to the valve.

[0060] For functional replacement of a heart valve, the transcatheter valve prosthesis 1 is fixated relative to the connection channel wall structure 25 and sealed against blood flow on the exterior of the transcatheter valve prosthesis 1 in the connection channel wall structure 25. To achieve this, tissue of the connection channel wall structure 25 adjacent to the circumferential groove 45 may be forced or placed inside the circumferential groove 45 to engage radially below the first 50 and second 55 pluralities of projections whereby the tissue is prevented from slipping out of the groove 45 by the first 50 and/or second 55 plurality of projections, wherein the free ends 60, 65 of the first 50 and/or second plurality 55 of projections may penetrate the tissue. The tissue of the connection channel wall structure 25 may be (completely) perforated, or example partially perforated, by the projections 50, 55 and may thereby be prevented from slipping out of the circumferential groove 45. The clamping member 80 or two or more clamping members 80 may be provided in the circumferential groove 45 to actively press tissue of the connection channel wall structure 25 against the free ends 60,65 so as to interlock the tissue with the free ends 60, 65. This results in the transcatheter valve prosthesis 1 being held in place more firmly and sealed against blood flow between the exterior of the tubular body 30 and the connection channel wall structure 25.

[0061] To place tissue in the circumferential groove 45 of the tubular body 30, a method for using a transcatheter valve prosthesis 1 may comprise using an elongate outer member 75 to radially and inwardly force tissue of the connection channel wall structure 25 into the circumferential groove 45 (which may or may not comprise a clamping member 80). With reference to Figure 3, the elongate outer member 75 may be disposed at an exterior of the connection channel wall structure 25 at a level of the circumferential groove 45. Then, with further reference to Figure 6b, a distance R5 between the elongate outer member 75 and the axis 35 of the tubular body is reduced (that means that also a distance between the bottom 46 of the circumferential groove 45 of the tubular body 30 and the elongate outer member 75 is reduced) so as to force tissue of the connection channel wall structure 25 into the circumferential groove 45 to fixate the tissue in the circumferential groove 45. The elongate outer member 75 may be handled via a catheter member 90 and an approach as described in relation to the transcatheter valve prosthesis 1 or any other approach may be used in order to bring the elongate outer member 75 in the vicinity of the connection channel wall structure 25. When the tissue of the connection channel wall structure 25 is held in the circumferential groove 45 by the projections 50, 55, the elongated member 75 (and the catheter member 90) may be removed from the heart or, as shown illustratively in Figure 7, the connecting means 91 of the catheter member 90 may be used in order to permanently connect two (free) ends of the elongate outer member 75 together and cut the ends so that elongate outer member 75 remains permanently on the exterior of a connection channel wall structure 25 on a level of the circumferential groove 45 of the tubular body 30 so as to additionally hold tissue of the connection channel wall structure 25 in the circumferential groove 45.

[0062] A method for using the transcatheter atrio-ventricular prosthesis 1 may result in the transcatheter valve prosthesis 1 being fixated to the connection channel wall structure 25 and being firmly held in place via the tissue that is held in the circumferential groove 45 by the free ends 60, 65, optionally supported by the clamping member 80 and/or the permanently disposed elongate outer member 75.

[0063] Features of the transcatheter atrio-ventricular valve prosthesis 1 and method steps involving the prosthesis that have been described herein (description and/or figures and/or claims) referring to a transcatheter atrio-ventricular valve prosthesis 1 comprising first 50 and second 55 pluralities of projections also apply to a transcatheter atrio-ventricular valve prosthesis 1 comprising one plurality of projections (50, 55) and vice versa. In particular, features described in the application (description, claims, figures) to further define the projections of the first and second plurality of projections are also applicable to only the first plurality of projections if, for example, the valve prosthesis only comprises the first plurality of projections (as it is, for example, the case in claim 1). All features herein are disclosed to be interchangeable between all embodiments of the transcatheter atrio-ventricular valve prosthesis 1.



## Claims

1. A transcatheter atrio-ventricular valve prosthesis (1) for functional replacement of an atrio-ventricular heart valve in a connection channel (10), having a circumferential connection channel wall structure (25), between the atrial chamber (15) and the ventricular chamber (20) of a heart, comprising

a radially expandable tubular body (30) to be disposed in the interior of the connection channel (10) and extending along an axis (35), and

a valve (40) arranged within and attached to the tubular body (30), wherein

the tubular body (30) is provided with an outer circumferential groove (45) which is open to the radial outside of the tubular body (30) and which defines a groove bottom (46), whereby the tubular body (30) is separated by the outer circumferential groove into first (31) and second (32) body sections, and wherein

the tubular body(30) is provided with a first plurality of projections (50, 55) which extend from the first or second body section (31, 32) in an axial direction of the tubular body (30) and each of which has a free end (60, 65) arranged to overlap the outer circumferential groove (45),

further comprising an elongate outer member (75) to be disposed at the exterior of the connection channel wall structure (25) at a level of the circumferential groove (45), wherein the elongate outer member (75) can at least partially extend around the tubular body (30) with valve tissue of the connection channel wall structure (25) being correspondingly circumferentially arranged between the tubular body (30) and the outer member (75) and in such a radial distance (R5) to the axis (35) of the tubular body (30) that the valve tissue of the connection channel wall structure (25) can be radially forced

into the outer circumferential groove (45) so as to be at least partially located radially below the projections (50, 55).

2. The transcatheter atrio-ventricular valve prosthesis (1) according to claim 1, wherein the first body section (31) is adapted to be arranged on a side of the atrial chamber (15) in the connection channel (10) and the second body section (32) is adapted to be arranged on a side of the ventricular chamber (20) in the connection channel (10), and wherein the first plurality of projections (50) extends from the second body section (32).

3. The transcatheter atrio-ventricular valve prosthesis (1) according to claim 1 or 2, wherein the elongate outer member (75) comprises a tubular structure having a central longitudinal axis so as to extend in the circumferential groove (45) in a circumferential direction of the tubular body (30), wherein the elongate outer member (75) has a crosssectional diameter (D2) transverse to its central longitudinal axis and wherein the crosssectional diameter (D2) optionally is larger than 2 mm and/or optionally is smaller than 15 mm.

4. The atrio-ventricular valve prosthesis (1) according to any preceding claim, wherein the elongate outer member (75) is formed by or comprises an inflatable member (75) which is adapted to be inflated by a substance so as to expand the elongate outer member (75).

5. The transcatheter atrio-ventricular valve prosthesis (1) according to any preceding claim, wherein the elongate outer member (75) is provided to be expandable and/or compressible in a radial direction of its crosssectional diameter (D2).
6. The atrio-ventricular valve prosthesis (1) according to claim 4, wherein the substance is a curable substance that is adapted to be cured in the inflatable member (75) so as to give the elongate outer member (75) rigidity.
7. The atrio-ventricular valve prosthesis (1) according to any preceding claim, wherein the elongate outer member (75) extends partially around the tubular body (30), optionally at least 180° or at least 270°, and has spaced and non-abutting free ends.
8. The atrio-ventricular valve prosthesis (1) according to any preceding claim, wherein the elongate outer member (75) is made from a mesh-type structure.
9. The transcatheter atrio-ventricular valve prosthesis (1) according to any preceding claim, wherein the tubular body (30) comprises a mesh-type body having elongate mesh elements (33) crossing each other at crossings (34), wherein the plurality of projections (50, 55) is formed monolithically integrally with the tubular body (30).
10. The transcatheter atrio-ventricular valve prosthesis (1) according to any preceding claim, wherein a diameter of the first body section (31) in a radial direction of axis (35) is larger than any diameter of the second body section (32) in a radial direction of axis (35).

11. The transcatheter atrio-ventricular valve prosthesis (1) according to any preceding claim, wherein

the tubular body(30) is provided with a first (50) and a second (55) plurality of projections which extend from the first and second body sections (31, 32), respectively, in opposite axial directions of the tubular body (30) and each of which has a free end (60, 65) arranged to overlap the outer circumferential groove (45).

12. The transcatheter atrio-ventricular valve prosthesis (1) according to any preceding claim, wherein the first (50) and/or the second (55) plurality of projections each are provided in a rectilinear shape.

13. The transcatheter atrio-ventricular valve prosthesis (1) according to any preceding claim, wherein the first (50) and/or second (55) plurality of projections extend from the first (31) and second (32) body sections, respectively, at a radial distance to the groove bottom (46) so as to define a hollow chamber (66) between the projections (50, 55) and the groove bottom (46).

14. The transcatheter atrio-ventricular valve prosthesis (1) according to any preceding claim, wherein the first (50) and/or second (55) plurality of projections extend from the first (31) and second (32) body sections, respectively, at an area adjacent to the radial outer circumference of the outer circumferential groove (45).

15. The transcatheter atrio-ventricular valve prosthesis (1) according to any preceding claim, wherein the first (50) and/or second (55) pluralities of projections extend in an angle ( $\beta$ ) to the axis (35) of the tubular body (30) radially inwardly into the outer circumferential groove (45), wherein the angle ( $\beta$ ) may be equal to or smaller than  $45^\circ$ , or equal to or smaller than  $30^\circ$ , or equal to or smaller than  $15^\circ$ .

16. The transcatheter atrio-ventricular valve prosthesis (1) according to any preceding claim, wherein the projections (50, 55) substantially extend in planes including the axis of the tubular body (30).

17. The transcatheter atrio-ventricular valve prosthesis (1) according to any preceding claim, wherein the free ends (60, 65) of a plurality of the first (50) and/or second (55) pluralities of projections are acute and/or sharpened ends.

18. The transcatheter atrio-ventricular valve prosthesis (1) according to any preceding claim, wherein the free ends (60, 65) of a plurality of the first (50) and/or second (55) pluralities of projections are provided with barbs or hooks (71).

19. The transcatheter atrio-ventricular valve prosthesis (1) according to any preceding claim, wherein the tubular body (30) comprises or is a mesh type body having elongated mesh elements (33) crossing each other at crossings (34), and wherein the projections (50, 55) extend from crossings (34) adjacent to the outer circumferential groove (45).

20. The transcatheter atrio-ventricular valve prosthesis (1) according to any of the preceding claims, wherein, when seen in an axial section along the tubular body (30), the direction of a curvature or bend in the axial profile between the groove (45) and the first body section (31) and/or between the groove (45) and the second body section (32) changes from a concave curvature of the groove (45) to a convex curvature at the transition between the groove (45) and first and/or second body section (31, 32).

21. The transcatheter atrio-ventricular valve prosthesis (1) according to any preceding claim, wherein the elongate outer member (75) comprises or is formed by one or more clamping members (80) which each comprises a tubular clamping member body which extends along an axis in a circumferential direction of the tubular member (30) and which is radially expandable with respect to the axis of the clamping member (80) so as to force the tissue of the circumferential connection channel wall structure (25) inwardly in radial direction of the tubular body (30) into the outer circumferential groove (45).

22. The transcatheter atrio-ventricular valve prosthesis (1) according any preceding claim, further comprising one or more clamping members (80) to be disposed within the circumferential groove (45) radially below the first and/or second plurality of projections (50, 55) with valve tissue of the connection channel wall structure (25) between the first and/or second plurality of projections and the respective clamping member (80), wherein the respective clamping member (80) applies a radial clamping force (85) against the groove bottom (46) and the valve tissue, so as to radially force the valve tissue towards the groove bottom (46).

23. The transcatheter atrio-ventricular valve prosthesis (1) according to any preceding claim, wherein the transcatheter atrio-ventricular valve prosthesis (1) is a sub-annularly anchoring prosthesis adapted to be implanted with the circumferential groove (45) being located on a side of a ventricular chamber (20) of a valve annulus of the heart valve and the circumferential groove (45) having a distance to the valve annulus.

24. The transcatheter atrio-ventricular valve prosthesis (1) according to any preceding claim, wherein the elongate outer member (75) comprises an angularly shaped cross section with a first angular leg (75a), extending with respect to axis (35) generally radially into the circumferential groove (45), and a second angular leg (75b) extending generally parallel to the axis (35) of the tubular body (30) on an outside of the tubular body (30) so as to be disposed between the second body section (32) of the tubular body (30) and a ventricular chamber wall of the heart.

25. Method for implanting a transcatheter atrio-ventricular valve prosthesis (1) comprising a tubular body (30) having a longitudinal axis (35), a circumferential groove (45) and a plurality of projections (50, 55) each having a free end (60, 65) arranged so as to partially overlap the groove (45), and an elongate outer member (75), the method comprising the steps of positioning the tubular body (30) inside a connection channel (10) between an atrial (15) and a ventricular chamber (20) of a heart, positioning the elongate outer member (75) on an outside of the connection channel at an axial level of the circumferential groove, and fixating the prosthesis (1) relative to the heart by

reducing a distance (R5) between the elongate outer member (75) and the tubular body (30) so that tissue of the connection channel is inserted into the groove (45) so as to at least partially be radially inside of the projections (50, 55) with respect to axis (35).

26. Method for implanting a transcatheter atrio-ventricular valve prosthesis (1) according to claim 25, further comprising positioning the tubular body (30) such that the groove (45) is positioned adjacent to the annulus of a native mitral valve towards the ventricular chamber (20), so that when the elongate outer member (75) is inserted into the groove (45), a sub-annular prosthesis anchoring is achieved by the engagement of the elongate outer member (75) in the groove (45).

27. The method according to claim 25 or 26, wherein the step of positioning the tubular body (30) comprises entering the heart cavity using an arterial retrograde approach and/or using a venous access and a puncture through the inter-atrial septum and/or using a trans-apical approach by puncturing through the apex of the heart and/or puncturing an atrial wall from an outside of the heart and/or using an femoral-arterial access through a puncture in the groin.

28. The method according to any of claims 25 to 27, wherein the elongate outer member (75) comprises a cross-sectional diameter (D2) and wherein the step of fixating the prosthesis (1) comprises changing the cross-sectional diameter (D2) of the elongate outer member (75) so as to reduce a radial distance (R5) between the elongate outer member (75) and the tubular body (30).



29. The method according to claim 28, wherein the elongate outer member (75) is formed by or comprises an inflatable member and wherein changing the cross-sectional diameter (D2) of the elongate outer member (75) comprises inflating the inflatable member.

30. The method according to claim 29, wherein inflating is achieved by infilling a curable substance into the inflatable member, and wherein the curable substance is cured in an inflated condition of the inflatable member.

31. The method according to anyone of claims 25 to 30, wherein the prosthesis (1) comprises a plurality of projections (50, 55) and wherein the step of fixating the prosthesis (1) comprises placing the elongate outer member (75) at least partially radially inwards of the projections (50, 55) with respect to axis (35), and optionally comprises piercing the the elongate outer member (75) with the plurality of projections (50, 55), so that the elongate outer member (75) is held by the plurality of projections (50, 55).

FIG 1

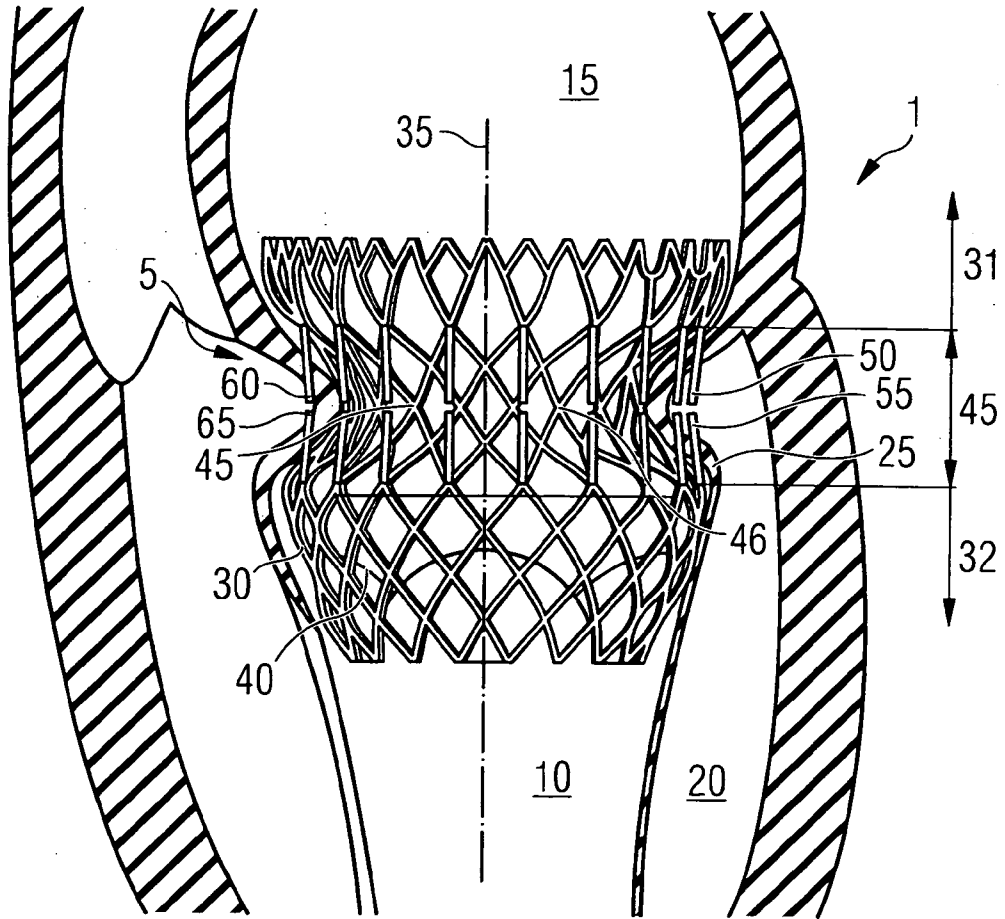

FIG 1a

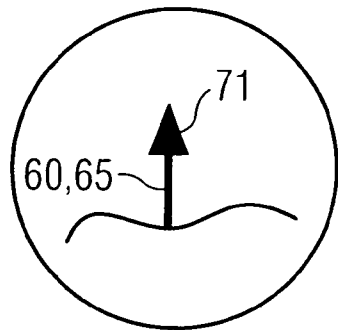

FIG 1b

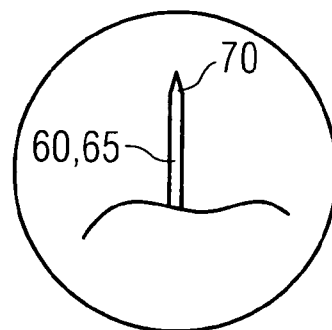

FIG 2

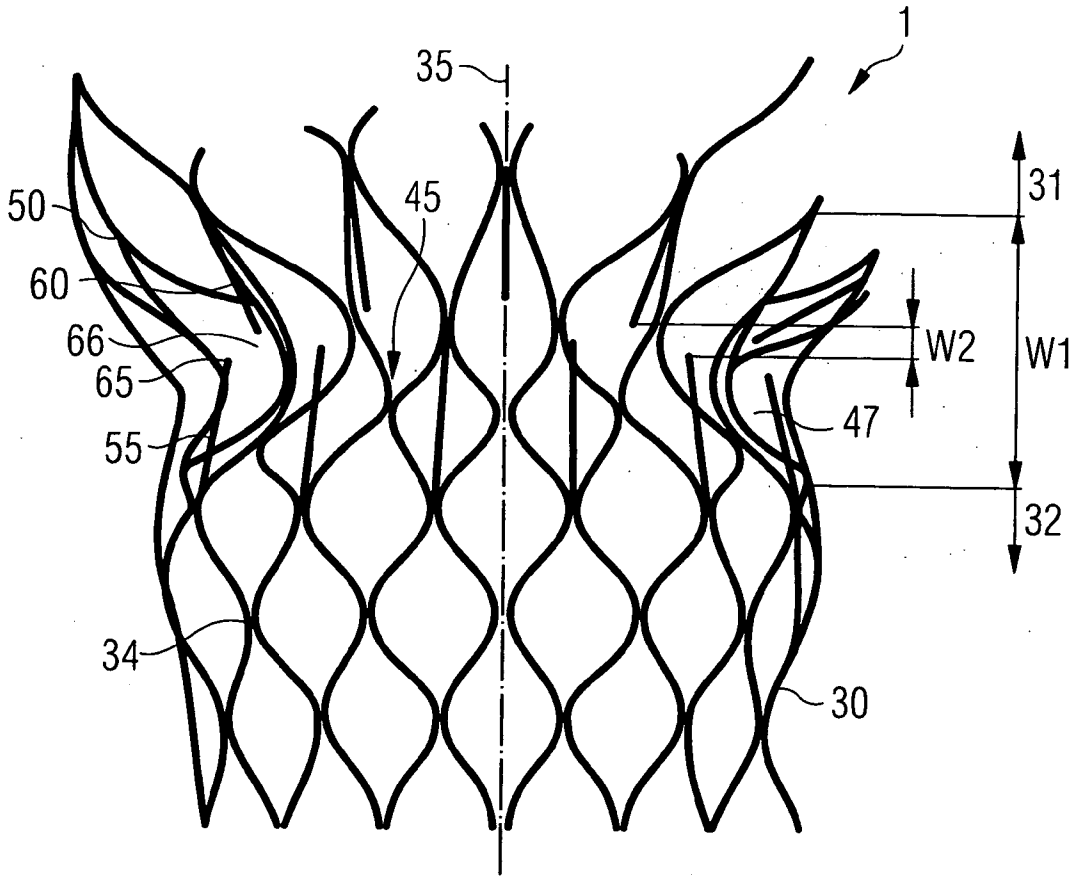

FIG 2a

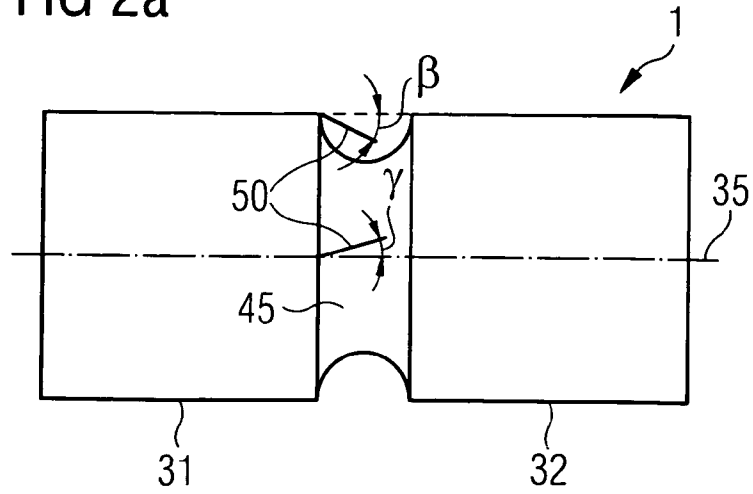

FIG 3

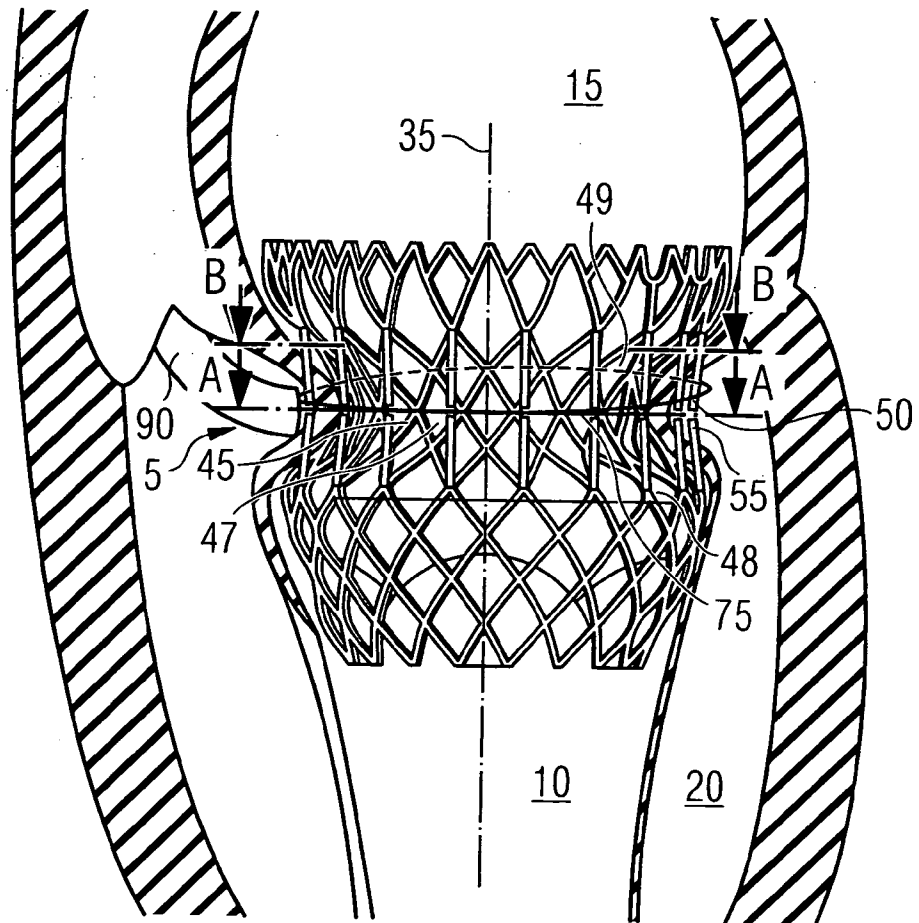

FIG 4

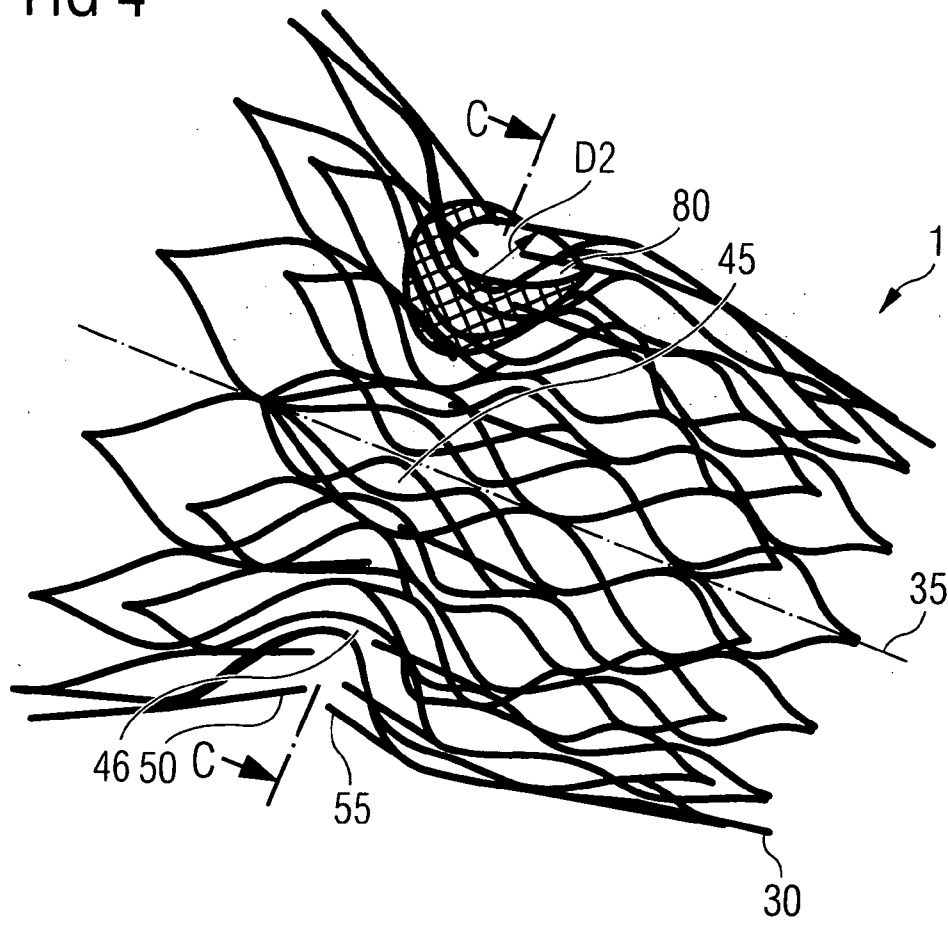

FIG 5

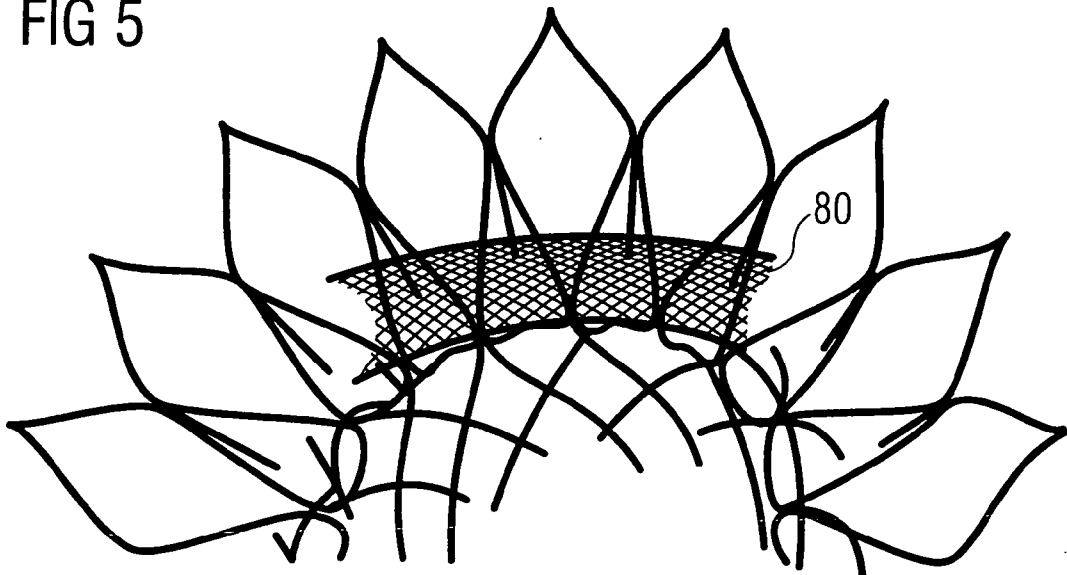

FIG 6a

A-A

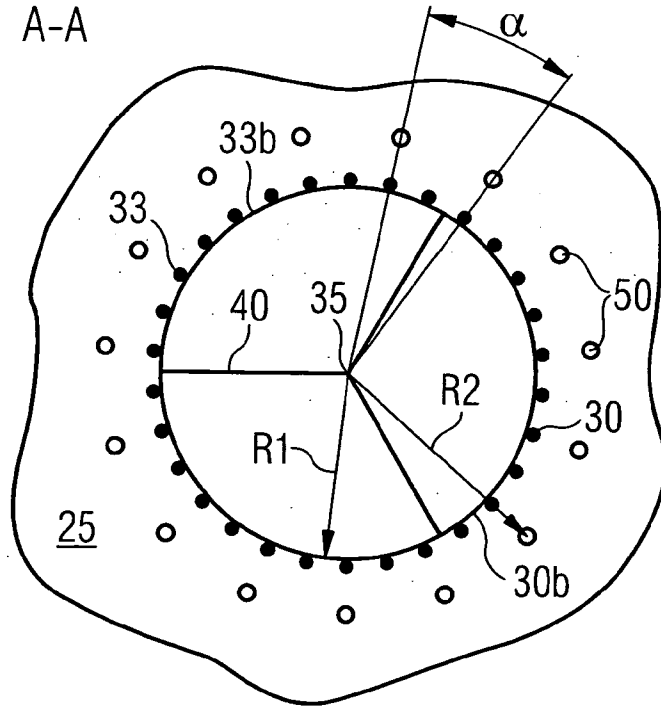

FIG 6b

B-B

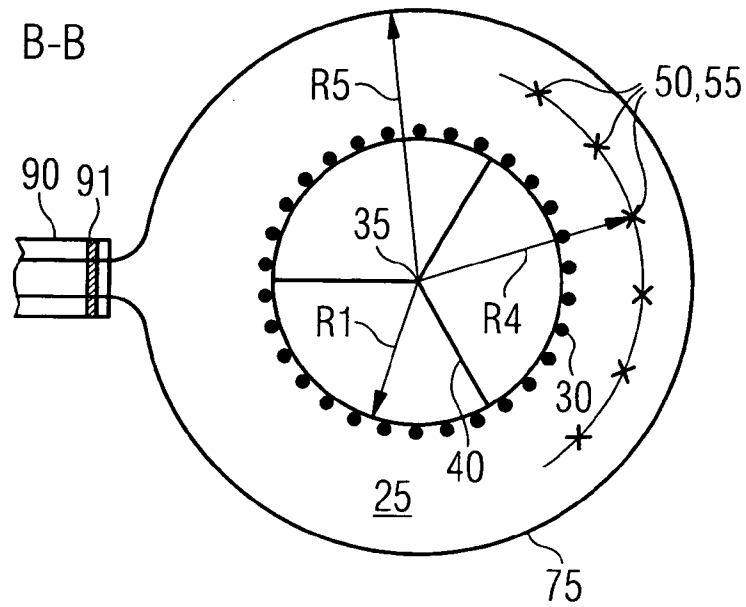

FIG 6c

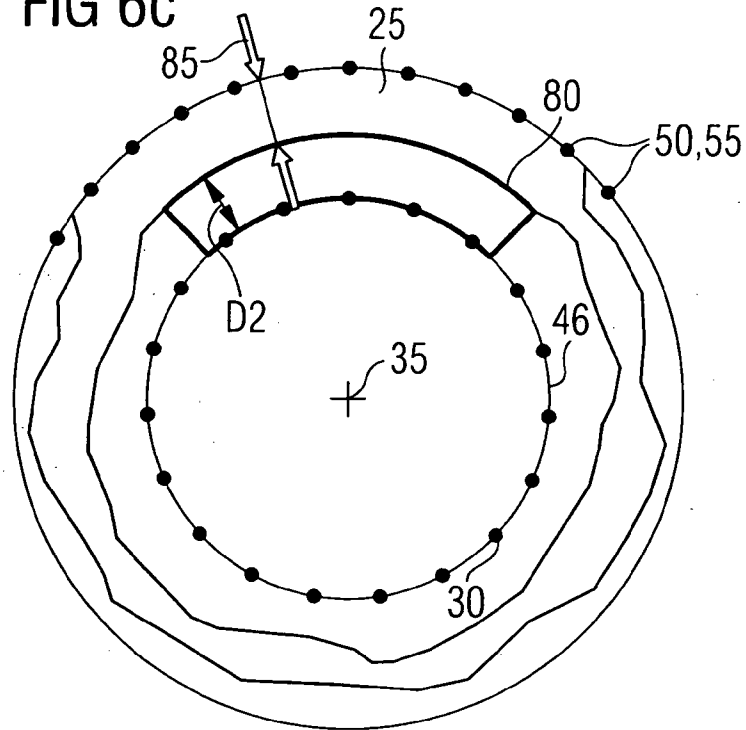

FIG 6d

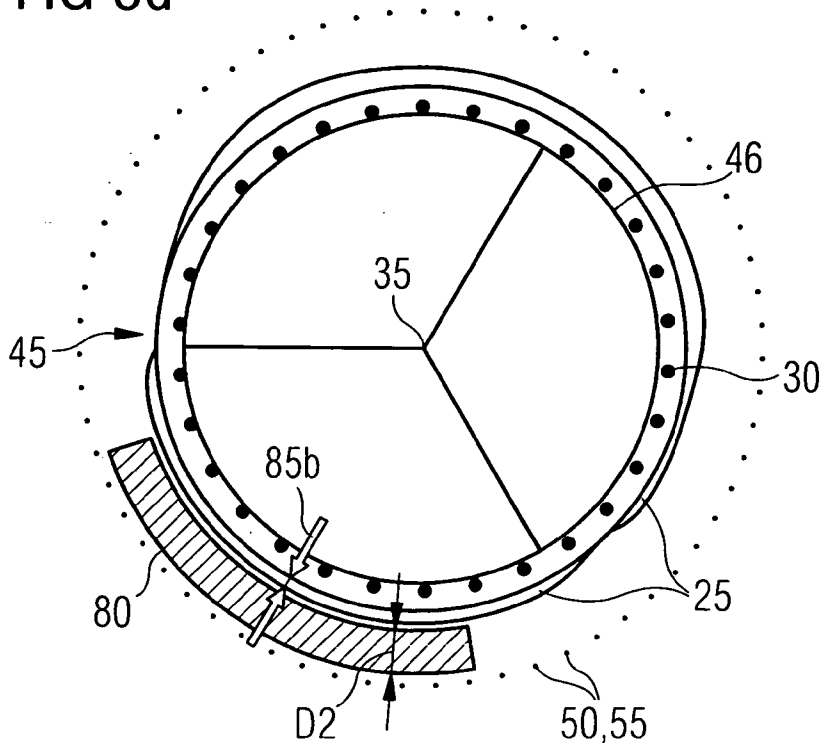

FIG 7

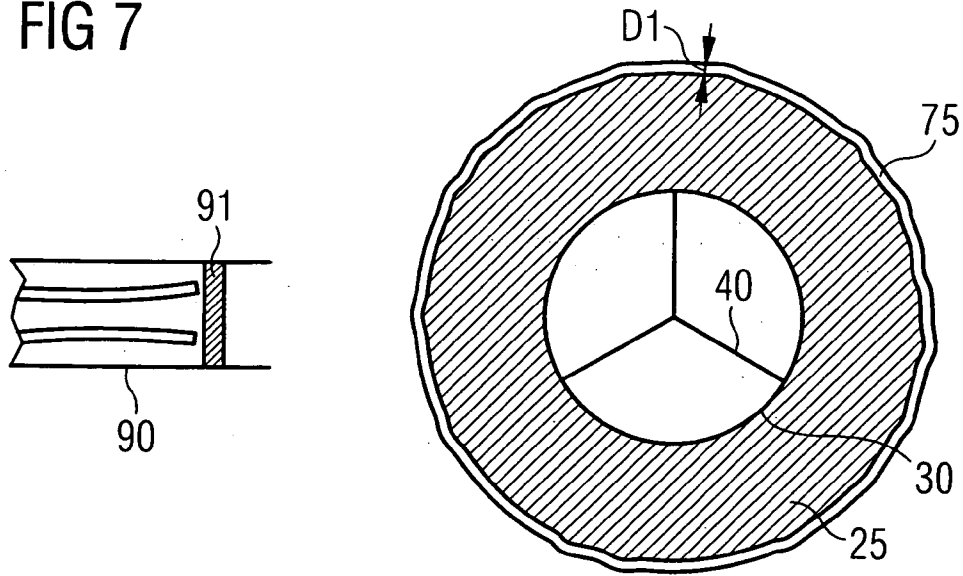

FIG 8

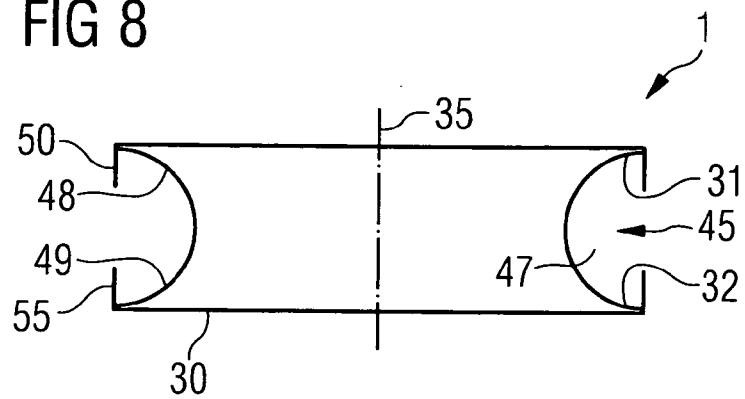



FIG 9a

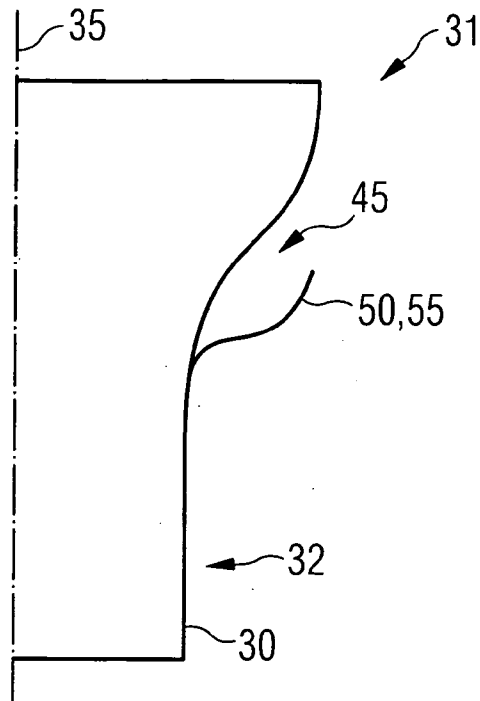

FIG 9b

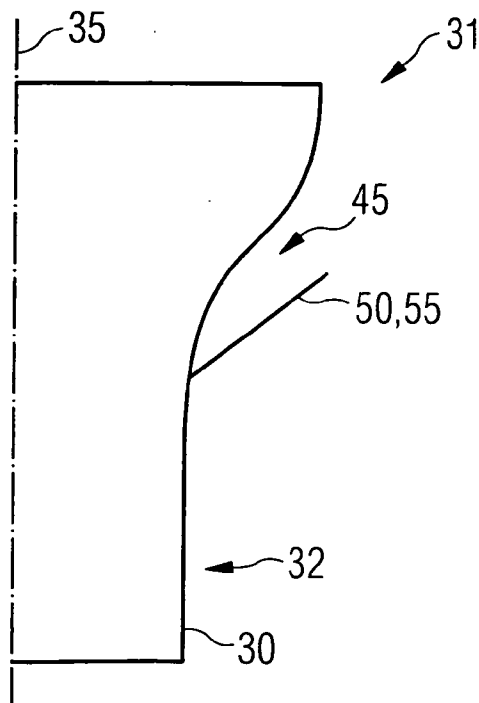

FIG 10a

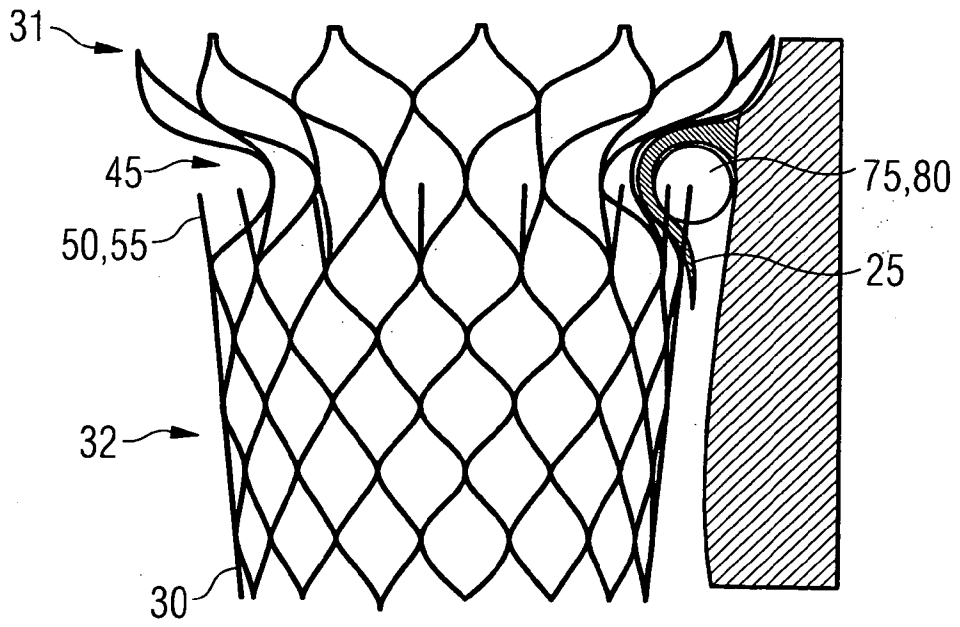

FIG 10b

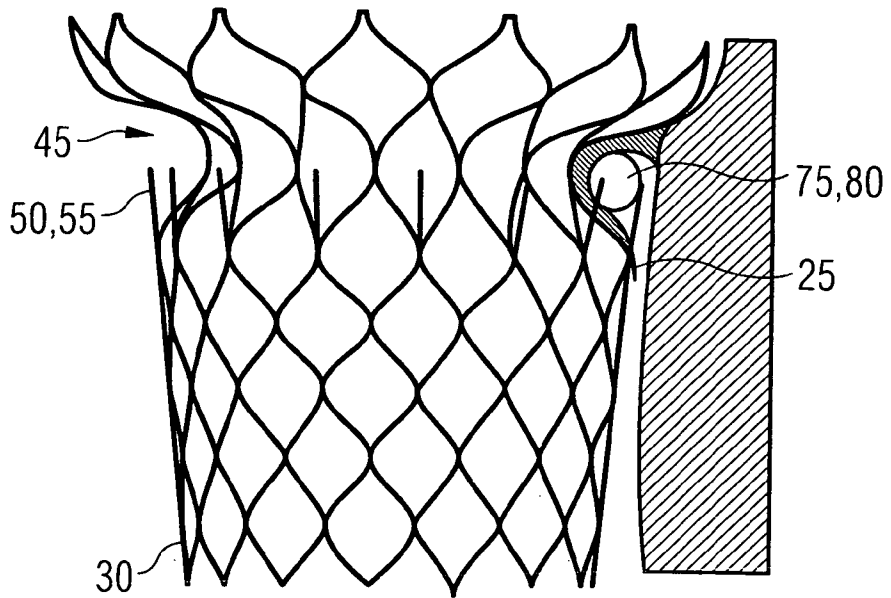

FIG 10c

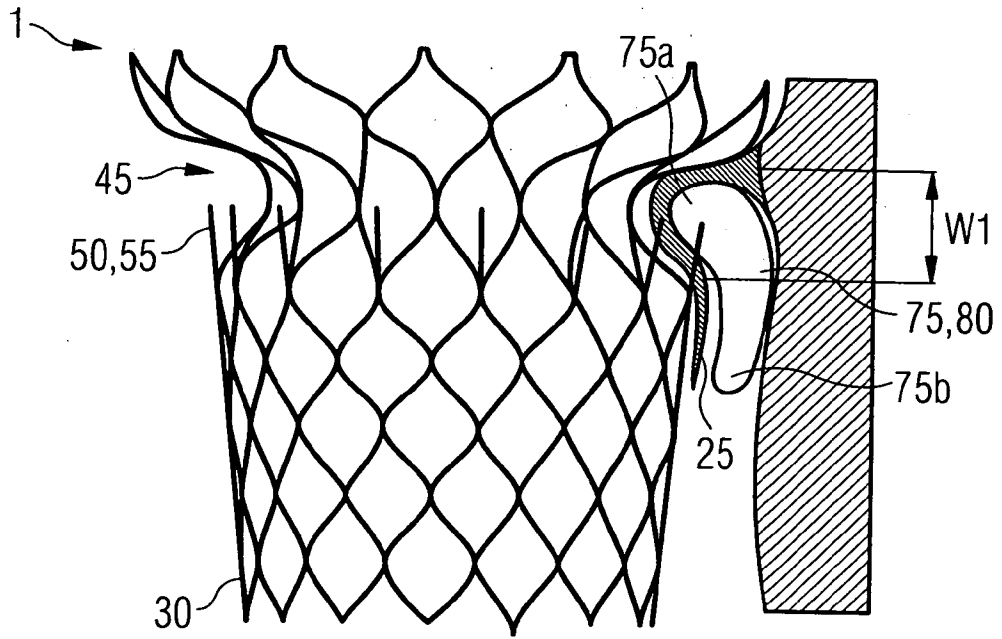

FIG 11a

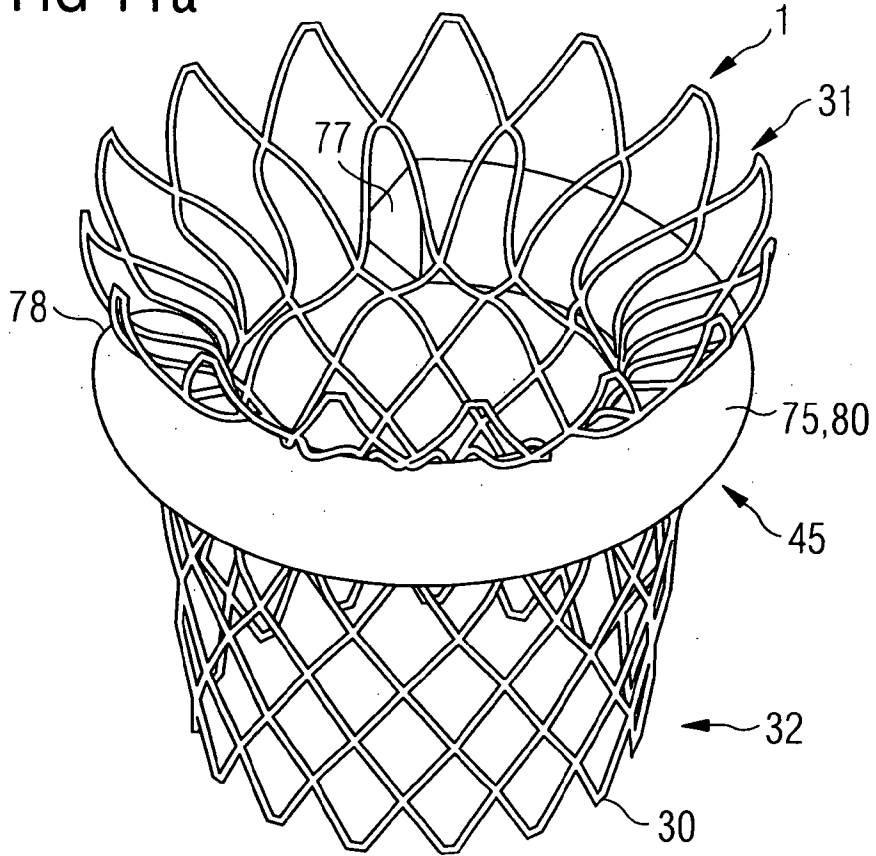

FIG 11b

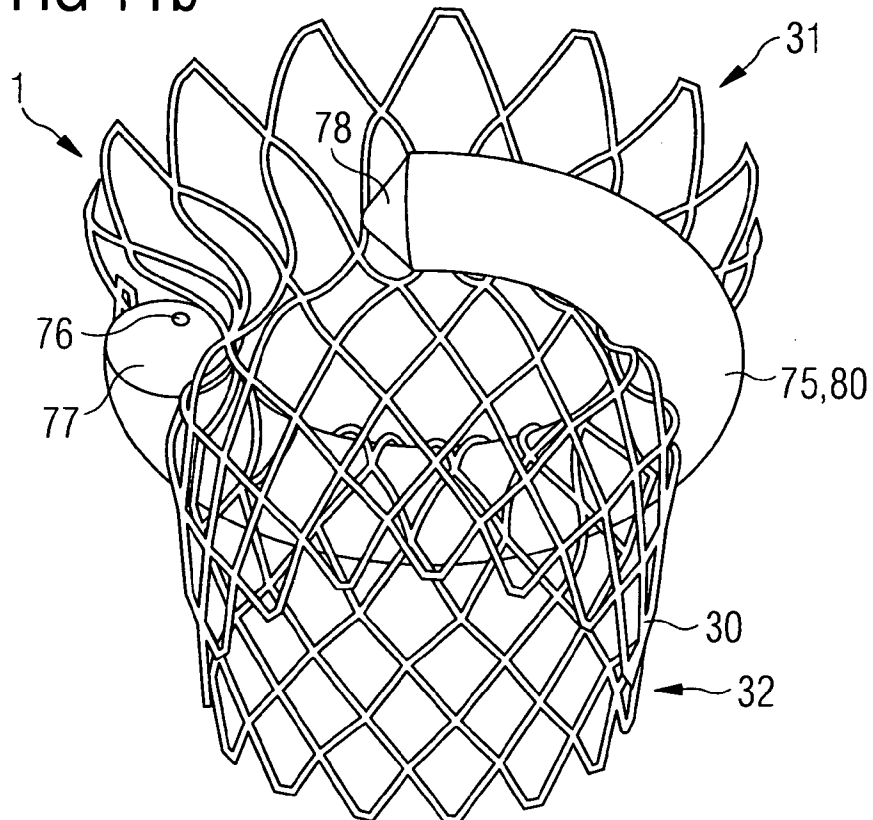

FIG 11c

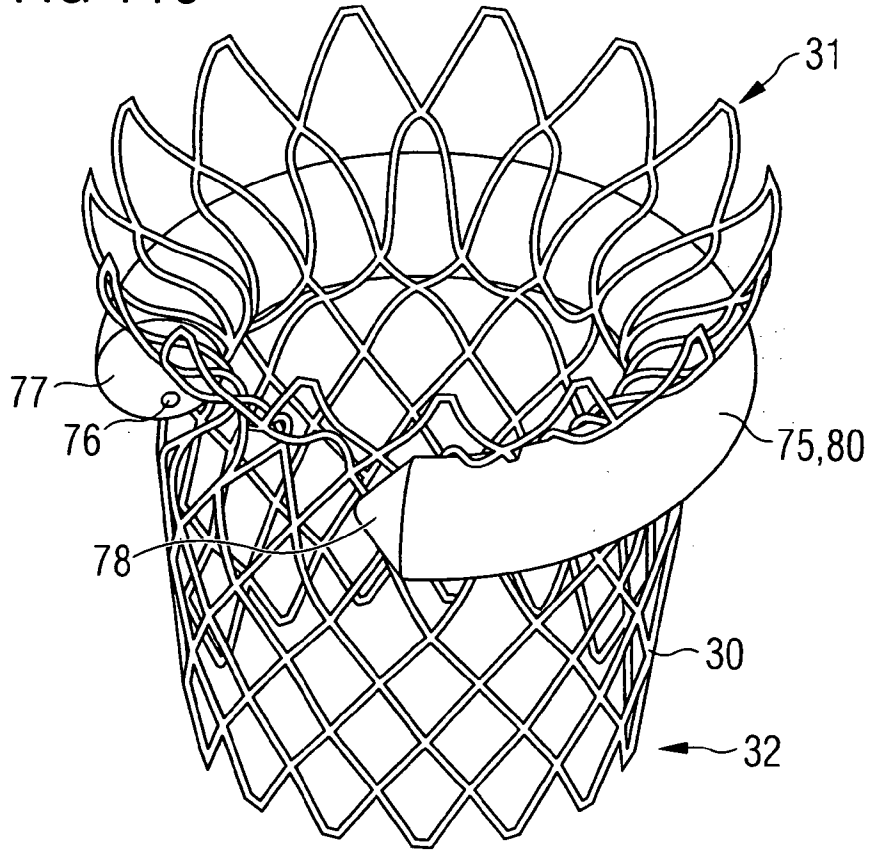
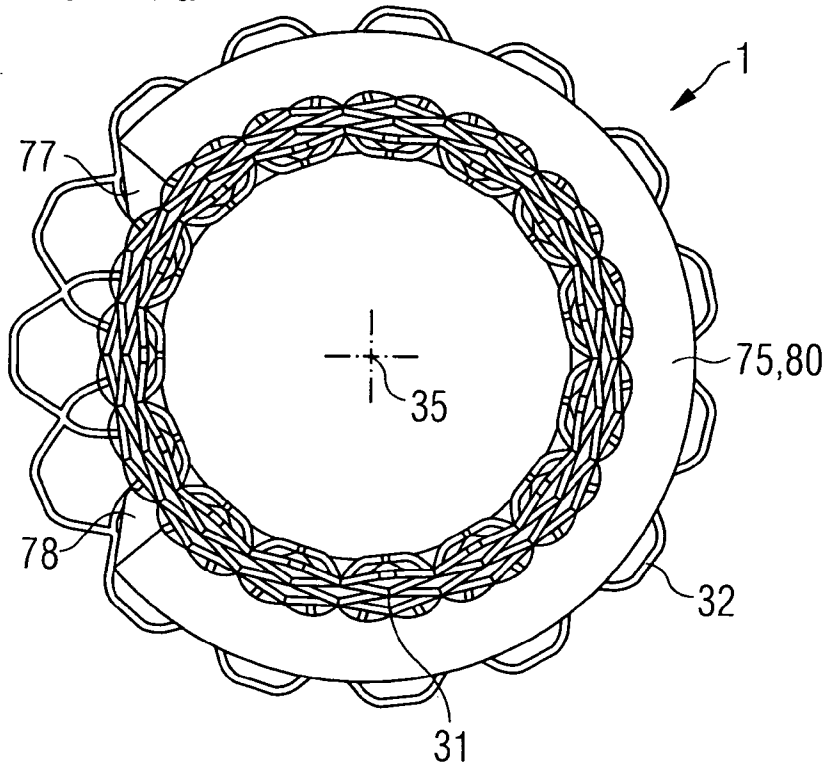

FIG 11d



INTERNATIONAL SEARCH REPORT

International application No  
PCT/EP2012/061237

A. CLASSIFICATION OF SUBJECT MATTER  
INV. A61F2/24  
ADD.  
According to International Patent Classification (IPC) or to both national classification and IPC

B. FIELDS SEARCHED  
Minimum documentation searched (classification system followed by classification symbols)  
A61F

Documentation searched other than minimum documentation to the extent that such documents are included in the fields searched

Electronic data base consulted during the international search (name of data base and, where practicable, search terms used)  
EPO-Internal, WPI Data

C. DOCUMENTS CONSIDERED TO BE RELEVANT

Category*	Citation of document, with indication, where appropriate, of the relevant passages	Relevant to claim No.
Y	US 2008/071361 A1 (TUVAL YOSI [IL] ET AL) 20 March 2008 (2008-03-20) paragraphs [0587], [0606], [0607]; figures 1,7A-E -----	1-24
Y	WO 2010/127041 A1 (CLEVELAND CLINIC FOUNDATION [US]) 4 November 2010 (2010-11-04) page 15, line 22 - line 28 figures 8,10 -----	1-24
Y	WO 2009/026563 A2 (DIRECT FLOW MEDICAL INC [US]; LASHINSKI RANDALL T [US]; BISHOP GORDON) 26 February 2009 (2009-02-26) paragraph [0136]; figures 3A-D -----	4
	-/--	

Further documents are listed in the continuation of Box C.

See patent family annex.

\* Special categories of cited documents :

- "A" document defining the general state of the art which is not considered to be of particular relevance
- "E" earlier application or patent but published on or after the international filing date
- "L" document which may throw doubts on priority claim(s) or which is cited to establish the publication date of another citation or other special reason (as specified)
- "O" document referring to an oral disclosure, use, exhibition or other means
- "P" document published prior to the international filing date but later than the priority date claimed

- "T" later document published after the international filing date or priority date and not in conflict with the application but cited to understand the principle or theory underlying the invention
- "X" document of particular relevance; the claimed invention cannot be considered novel or cannot be considered to involve an inventive step when the document is taken alone
- "Y" document of particular relevance; the claimed invention cannot be considered to involve an inventive step when the document is combined with one or more other such documents, such combination being obvious to a person skilled in the art
- "&" document member of the same patent family

Date of the actual completion of the international search  10 September 2012	Date of mailing of the international search report  19/10/2012
--	--

Name and mailing address of the ISA/ European Patent Office, P.B. 5818 Patentlaan 2 NL - 2280 HV Rijswijk Tel. (+31-70) 340-2040, Fax: (+31-70) 340-3016	Authorized officer  Geuer, Melanie
--	--

## INTERNATIONAL SEARCH REPORT

International application No  
PCT/EP2012/061237

C(Continuation). DOCUMENTS CONSIDERED TO BE RELEVANT

Category*	Citation of document, with indication, where appropriate, of the relevant passages	Relevant to claim No.
A	FR 2 874 812 A1 (PEROUSE SOC PAR ACTIONS SIMPLI [FR]) 10 March 2006 (2006-03-10) page 5, line 15 - line 29 figures 1-8 -----	1-24

# INTERNATIONAL SEARCH REPORT

International application No.  
PCT/EP2012/061237

## Box No. II Observations where certain claims were found unsearchable (Continuation of item 2 of first sheet)

This international search report has not been established in respect of certain claims under Article 17(2)(a) for the following reasons:

1.  Claims Nos.: **25-31**  
because they relate to subject matter not required to be searched by this Authority, namely:  
**Rule 39.1(iv) PCT - Method for treatment of the human or animal body by surgery**
2.  Claims Nos.:  
because they relate to parts of the international application that do not comply with the prescribed requirements to such an extent that no meaningful international search can be carried out, specifically:
3.  Claims Nos.:  
because they are dependent claims and are not drafted in accordance with the second and third sentences of Rule 6.4(a).

## Box No. III Observations where unity of invention is lacking (Continuation of item 3 of first sheet)

This International Searching Authority found multiple inventions in this international application, as follows:

1.  As all required additional search fees were timely paid by the applicant, this international search report covers all searchable claims.
2.  As all searchable claims could be searched without effort justifying an additional fees, this Authority did not invite payment of additional fees.
3.  As only some of the required additional search fees were timely paid by the applicant, this international search report covers only those claims for which fees were paid, specifically claims Nos.:
4.  No required additional search fees were timely paid by the applicant. Consequently, this international search report is restricted to the invention first mentioned in the claims; it is covered by claims Nos.:

### Remark on Protest

- The additional search fees were accompanied by the applicant's protest and, where applicable, the payment of a protest fee.
- The additional search fees were accompanied by the applicant's protest but the applicable protest fee was not paid within the time limit specified in the invitation.
- No protest accompanied the payment of additional search fees.



# INTERNATIONAL SEARCH REPORT

Information on patent family members

International application No PCT/EP2012/061237
---

Patent document cited in search report	Publication date	Patent family member(s)	Publication date	
US 2008071361	A1	20-03-2008	AU 2007298481 A1	27-03-2008
			CA 2663957 A1	27-03-2008
			EP 2068767 A2	17-06-2009
			US 2008071361 A1	20-03-2008
			US 2008071362 A1	20-03-2008
			US 2008071363 A1	20-03-2008
			US 2008071366 A1	20-03-2008
			US 2008071368 A1	20-03-2008
			US 2008071369 A1	20-03-2008
			US 2010131054 A1	27-05-2010
			US 2010137979 A1	03-06-2010
			US 2011288634 A1	24-11-2011
			US 2012046741 A1	23-02-2012
			US 2012046742 A1	23-02-2012
			US 2012101570 A1	26-04-2012
			US 2012185039 A1	19-07-2012
WO 2008035337 A2	27-03-2008			
WO 2010127041	A1	04-11-2010	AU 2010241596 A1	24-11-2011
			CA 2760461 A1	04-11-2010
			EP 2429455 A1	21-03-2012
			US 2010312333 A1	09-12-2010
			WO 2010127041 A1	04-11-2010
WO 2009026563	A2	26-02-2009	AU 2008288796 A1	26-02-2009
			CA 2697364 A1	23-02-2009
			EP 2190379 A2	02-06-2010
			JP 2010536504 A	02-12-2010
			US 2009088836 A1	02-04-2009
			US 2011160846 A1	30-06-2011
			WO 2009026563 A2	26-02-2009
FR 2874812	A1	10-03-2006	BR PI0515635 A	29-07-2008
			CN 101014302 A	08-08-2007
			EP 1791500 A2	06-06-2007
			FR 2874812 A1	10-03-2006
			US 2008039934 A1	14-02-2008
			WO 2006027500 A2	16-03-2006