



US 20130226240A1

(19) **United States**

(12) **Patent Application Publication**
Abdou

(10) **Pub. No.: US 2013/0226240 A1**

(43) **Pub. Date: Aug. 29, 2013**

(54) **SPINOUS PROCESS FIXATION DEVICES AND METHODS OF USE**

(52) **U.S. Cl.**
CPC *A61B 17/7067* (2013.01)
USPC **606/248**

(71) Applicant: **Samy Abdou**, San Diego, CA (US)

(72) Inventor: **Samy Abdou**, San Diego, CA (US)

(73) Assignee: **Samy ABDON**, San Diego, CA (US)

(21) Appl. No.: **13/774,905**

(22) Filed: **Feb. 22, 2013**

Related U.S. Application Data

(60) Provisional application No. 61/634,022, filed on Feb. 22, 2012.

Publication Classification

(51) **Int. Cl.**
A61B 17/70 (2006.01)

(57) **ABSTRACT**

Orthopedic implant and methods of implantation for fixing adjacent bones. In one embodiment, the implant includes a locking mechanism that is adapted to be advanced by a locking instrument, wherein advancement of the locking mechanism in a first direction produces rotation of a first rigid abutment surface of the implant from a first orientation to a second orientation, and continued advancement of the locking mechanism produces advancement of the first rigid abutment surface towards a second rigid abutment surface of the implant. The continued advancement may also place a compressive load onto the implant sufficient to immobilize the implant relative to a first bony surface and a second bony surface.

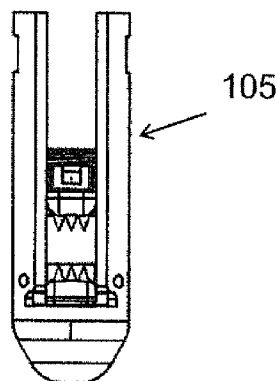
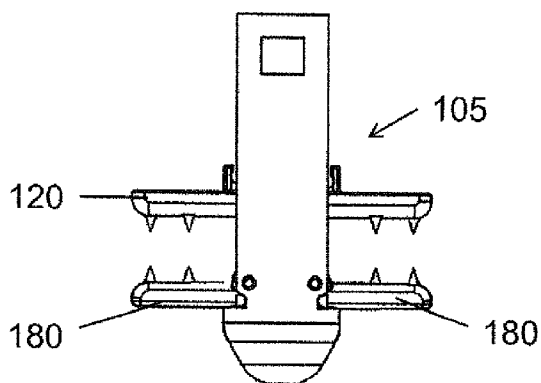
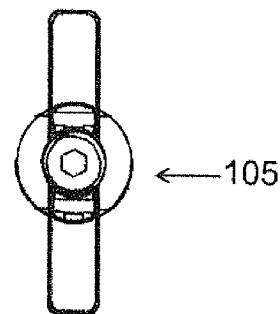
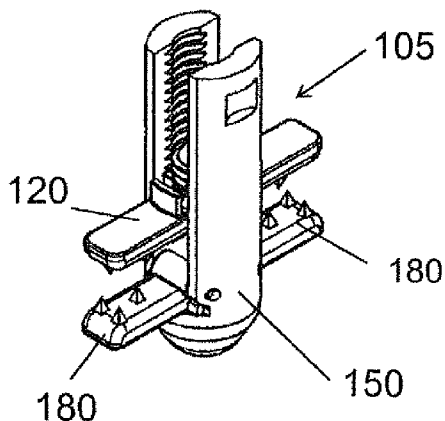

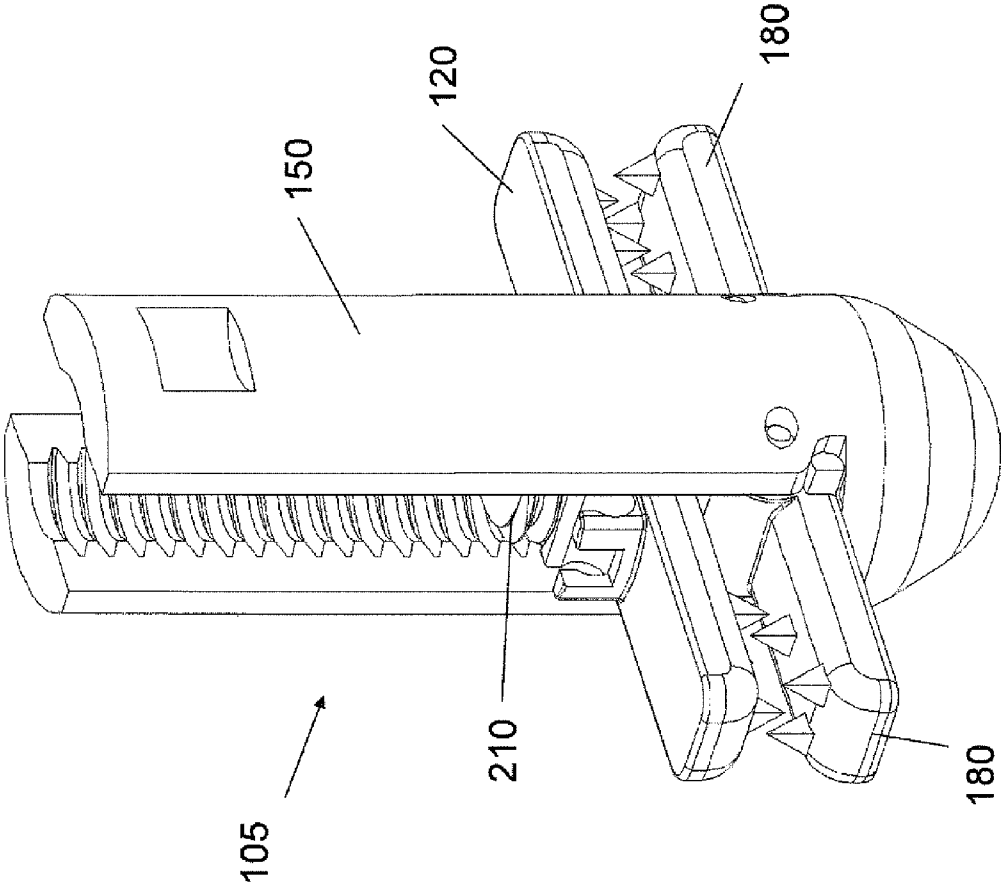

Fig. 1

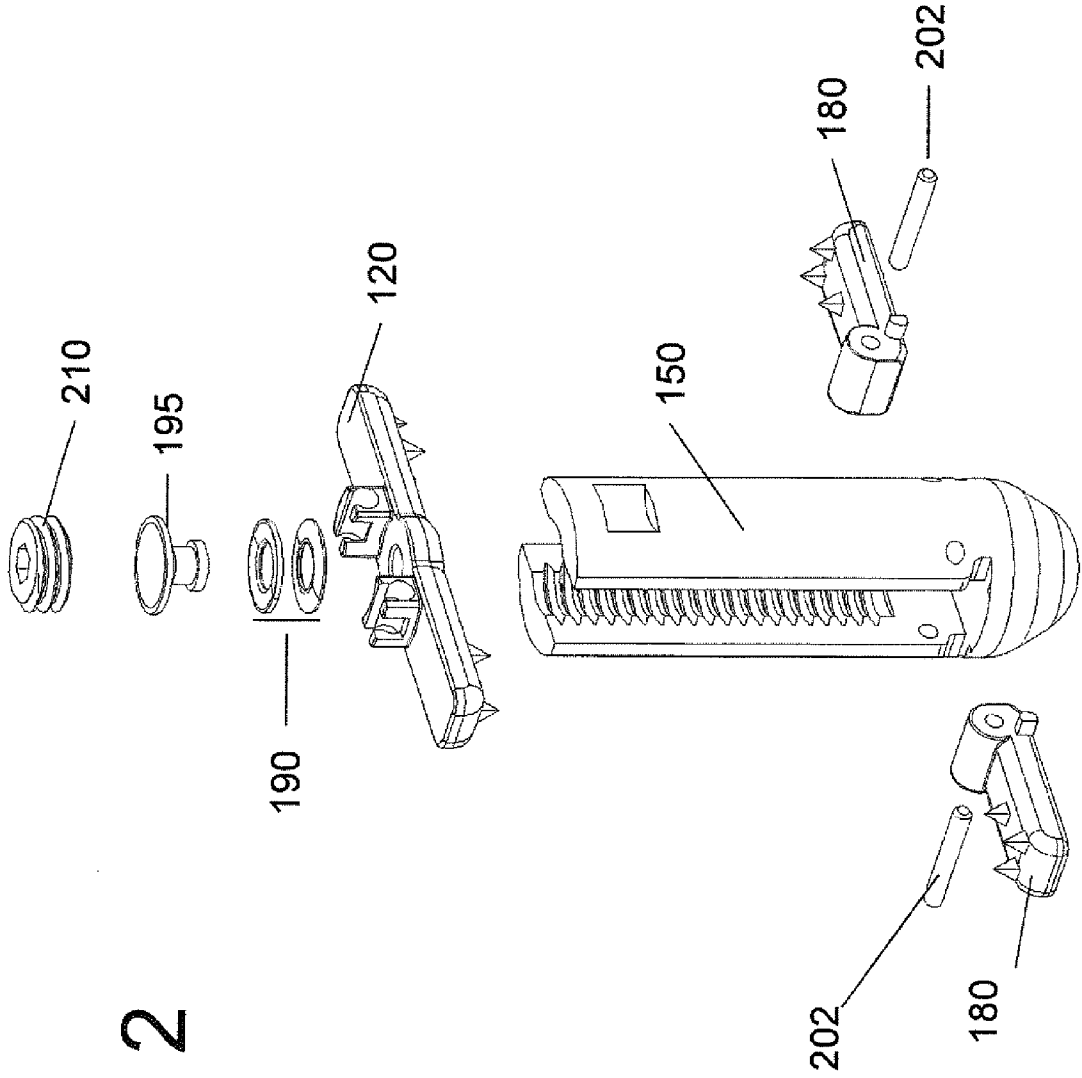

Fig. 2

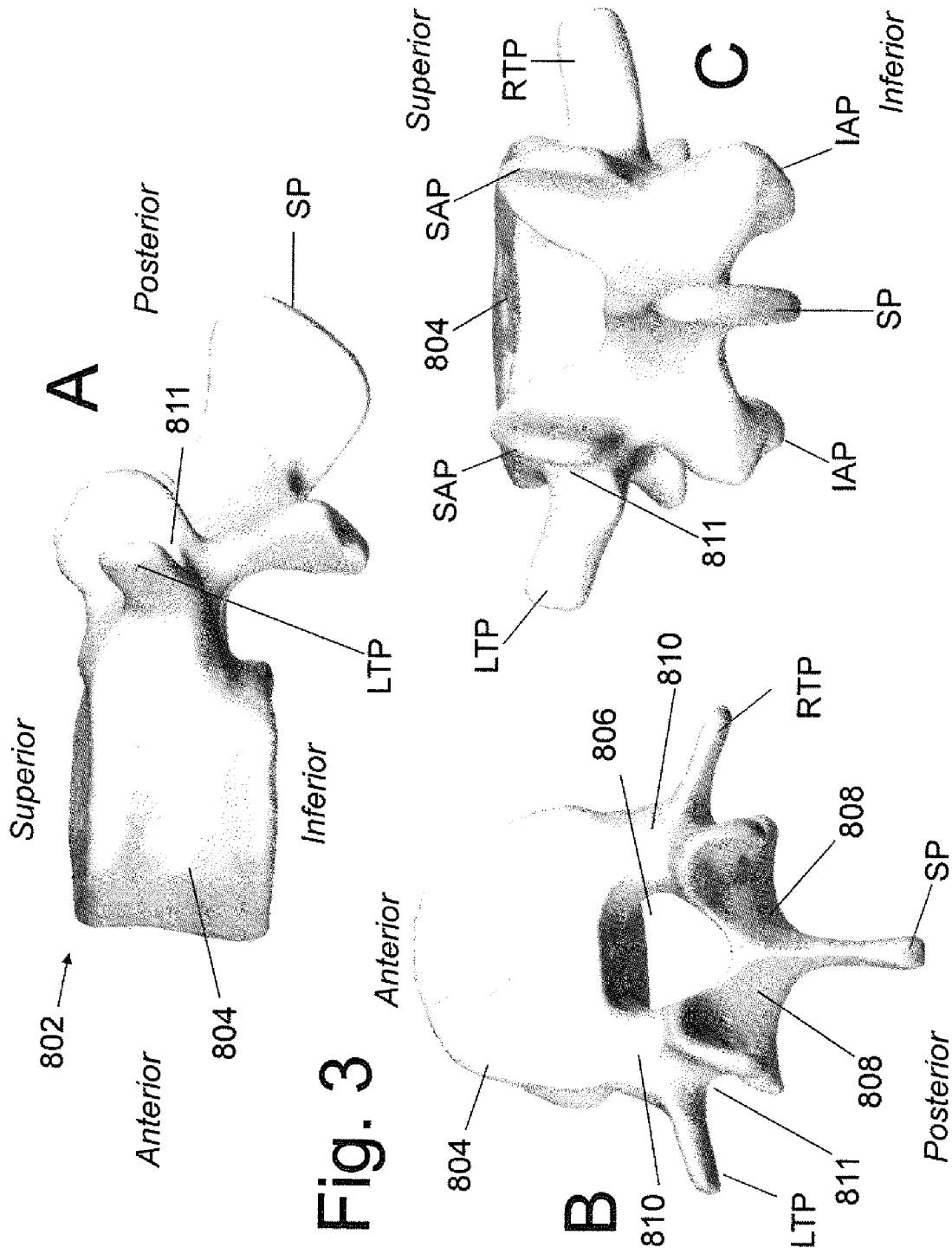

Fig. 3

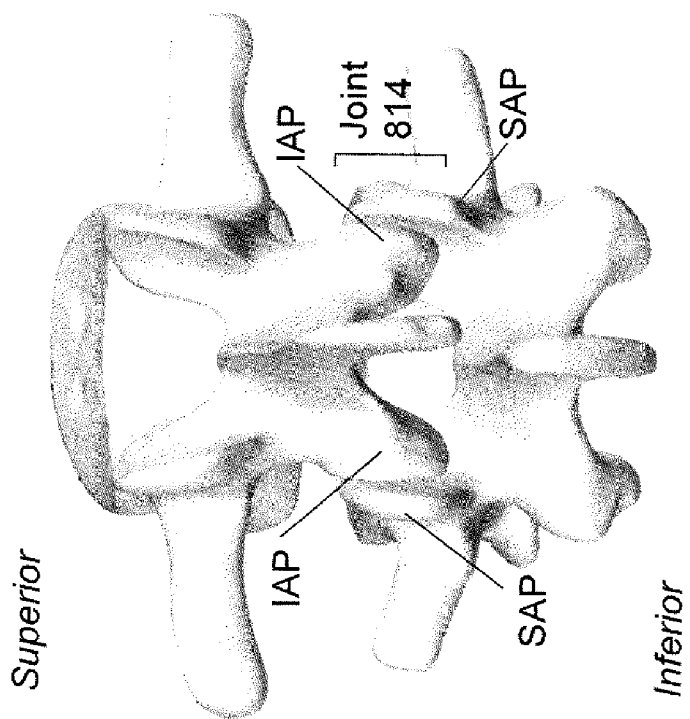

Fig. 4A

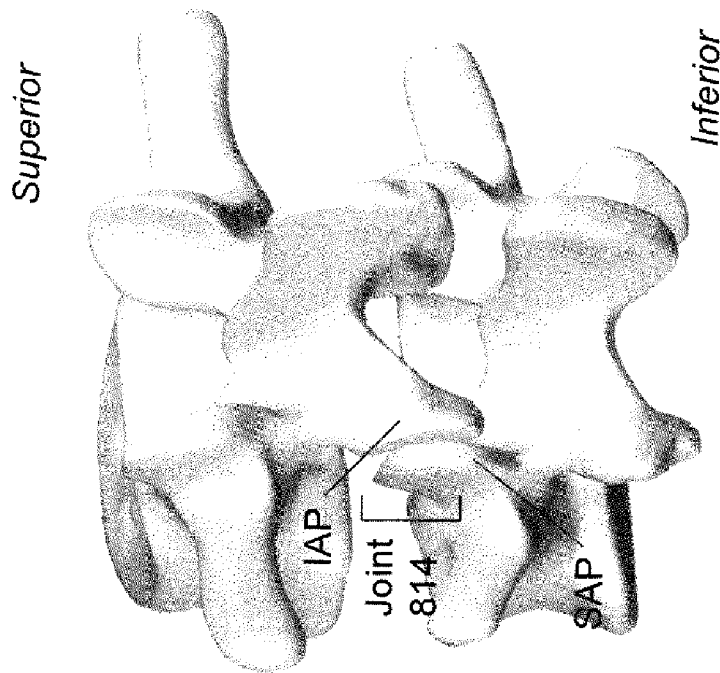
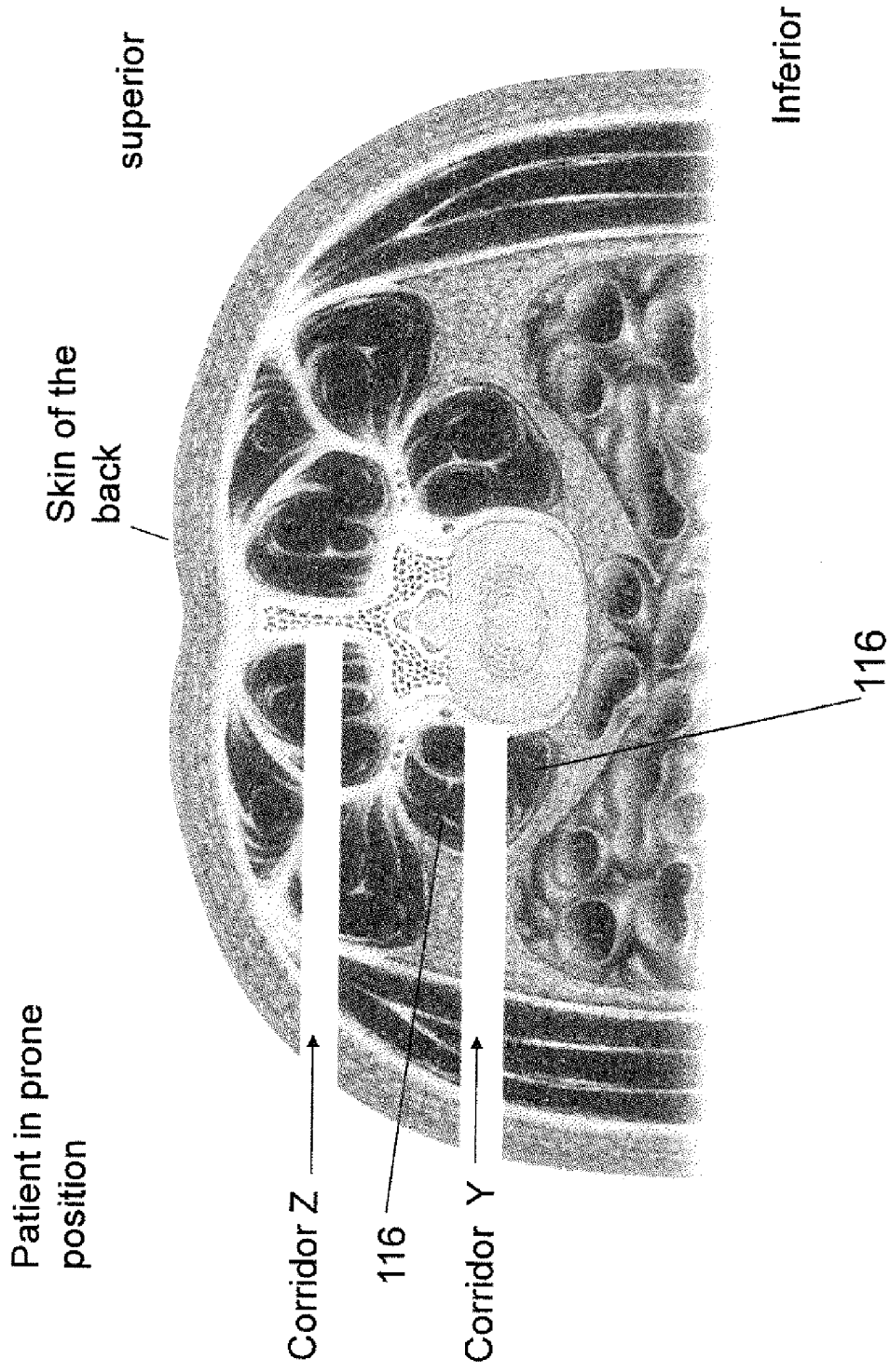

Fig. 4B

Fig. 5



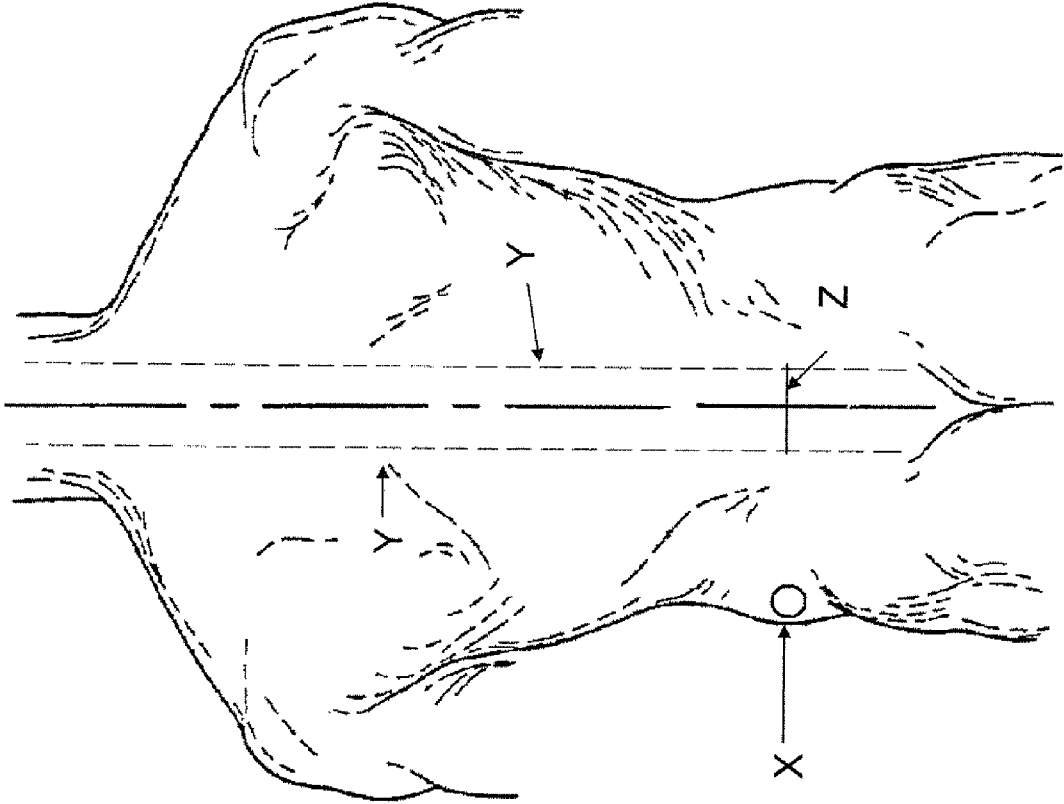

Fig. 6

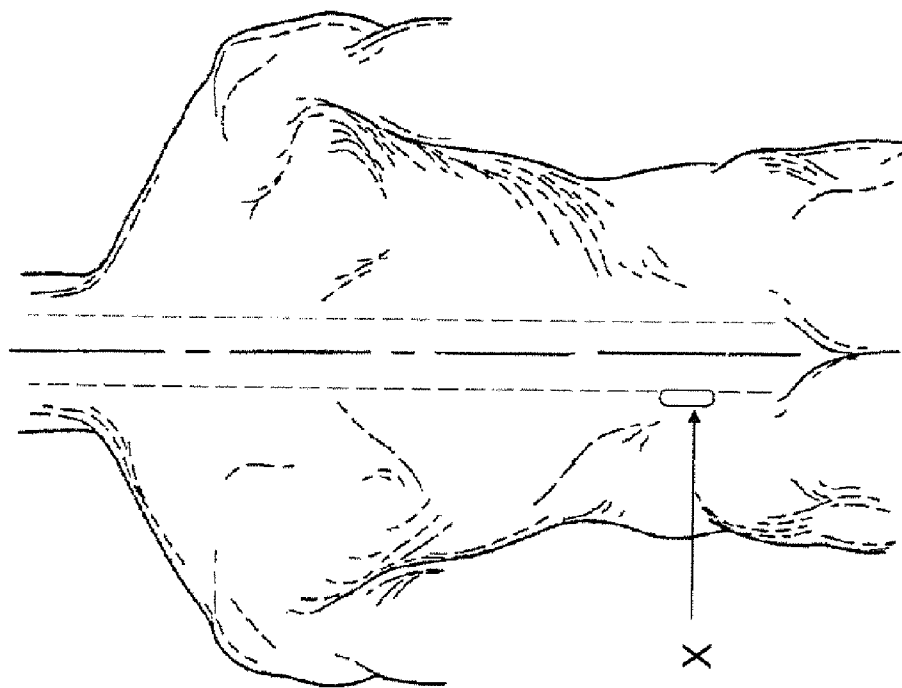

Fig. 7A

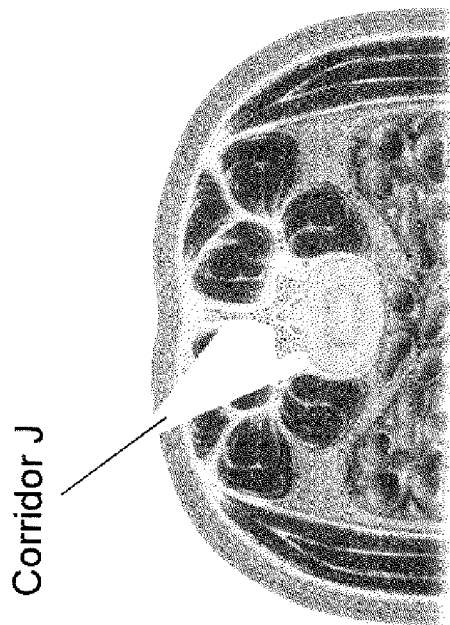

Fig. 7B

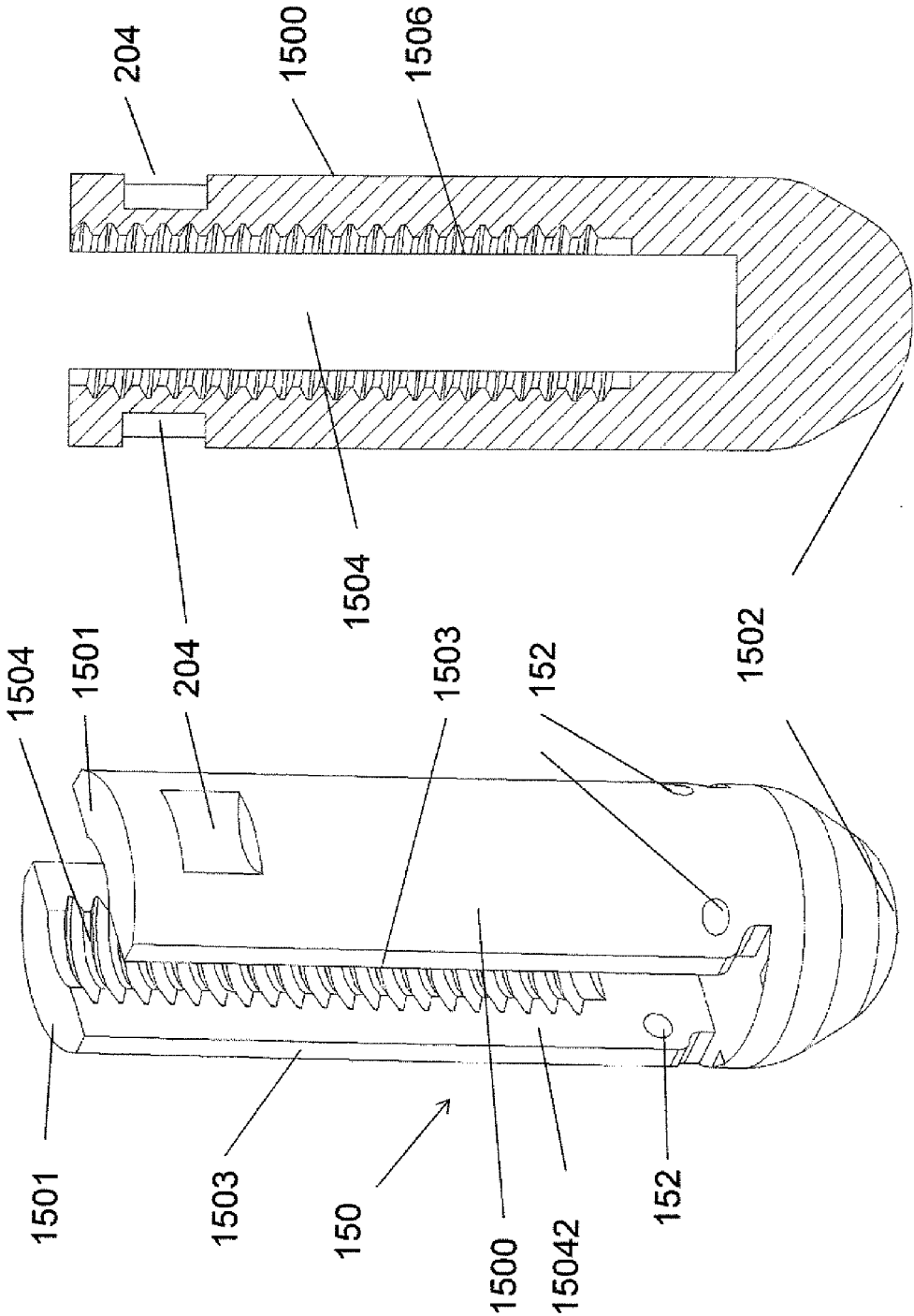
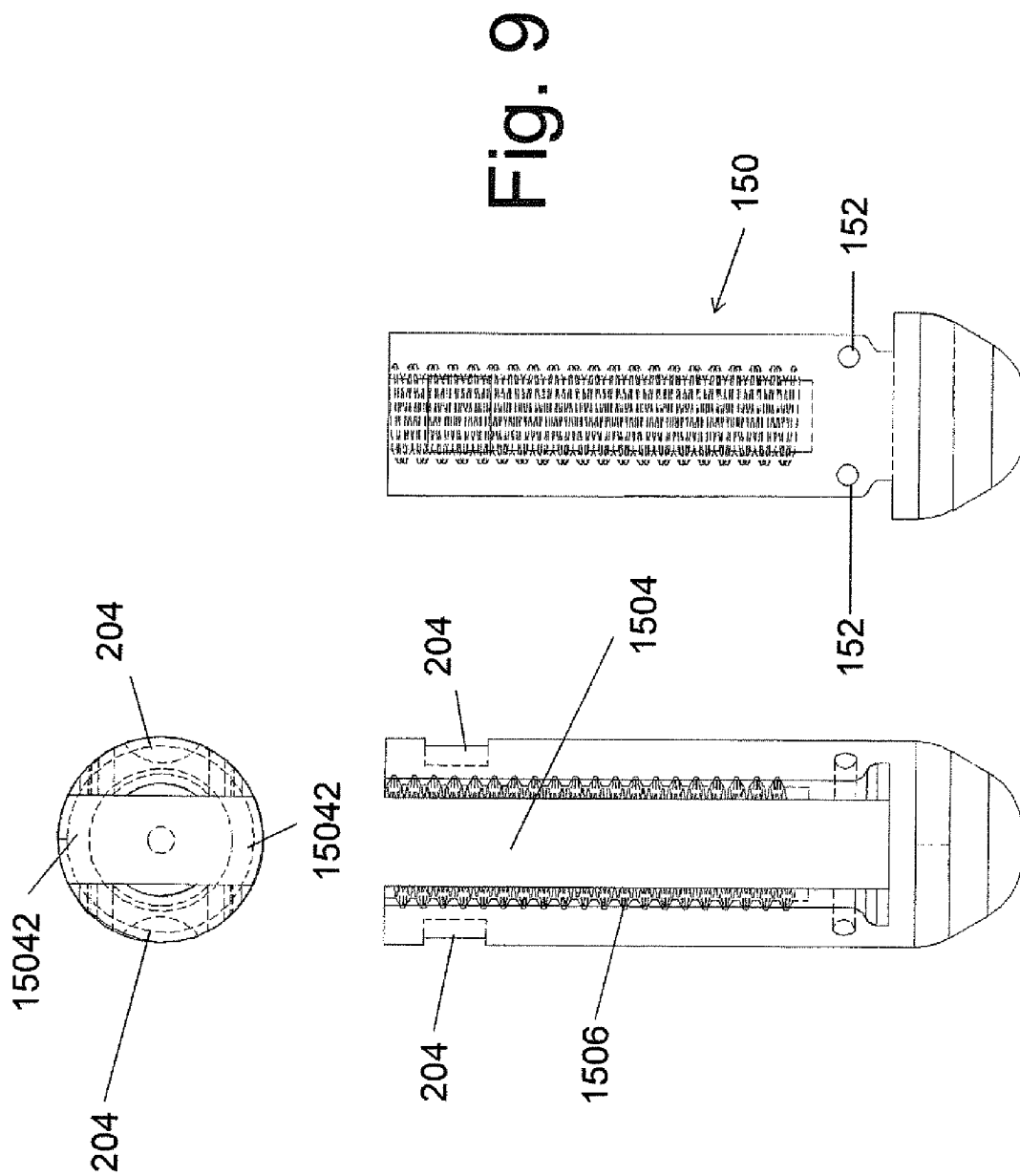

Fig. 8



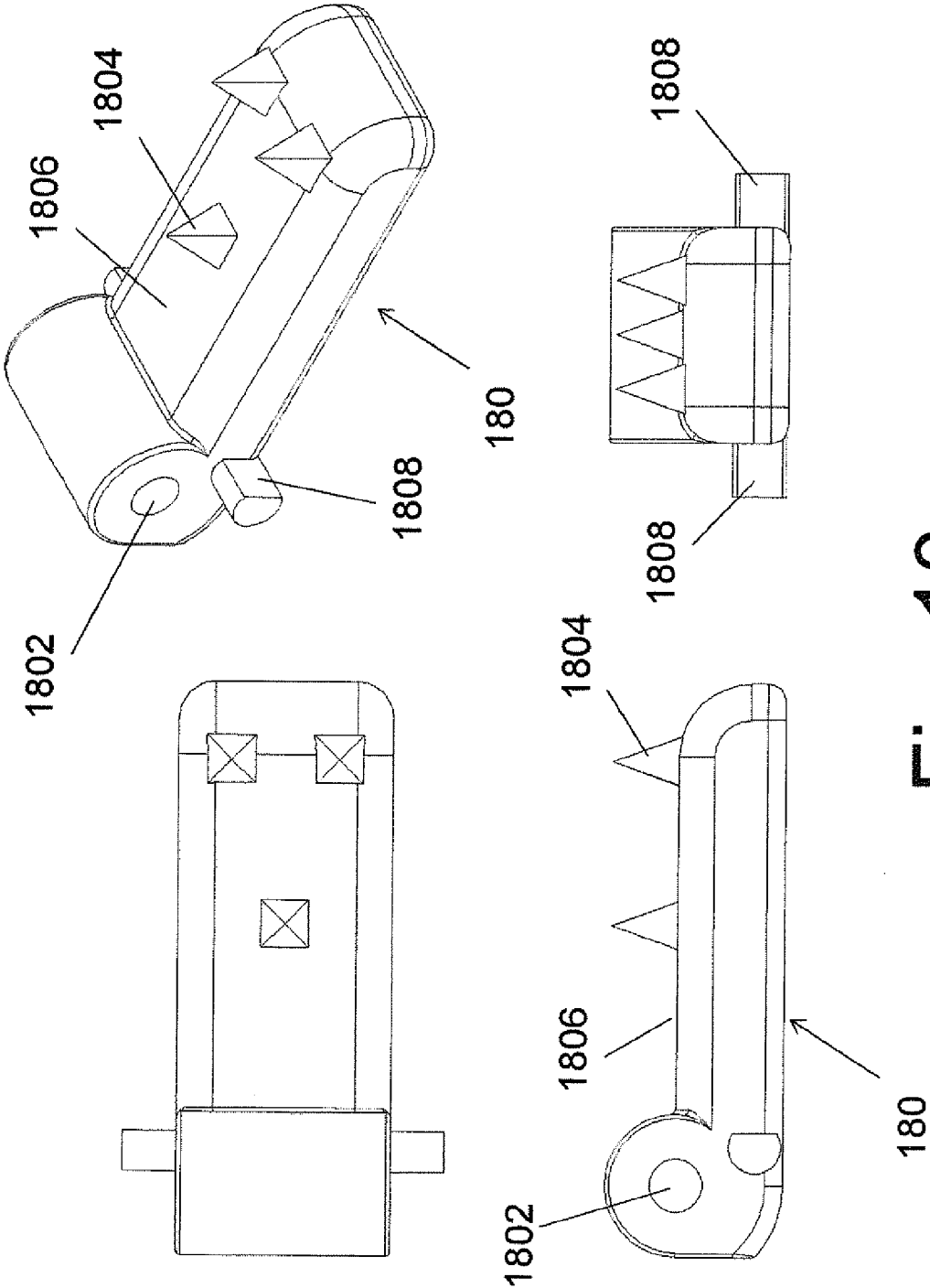

Fig. 10

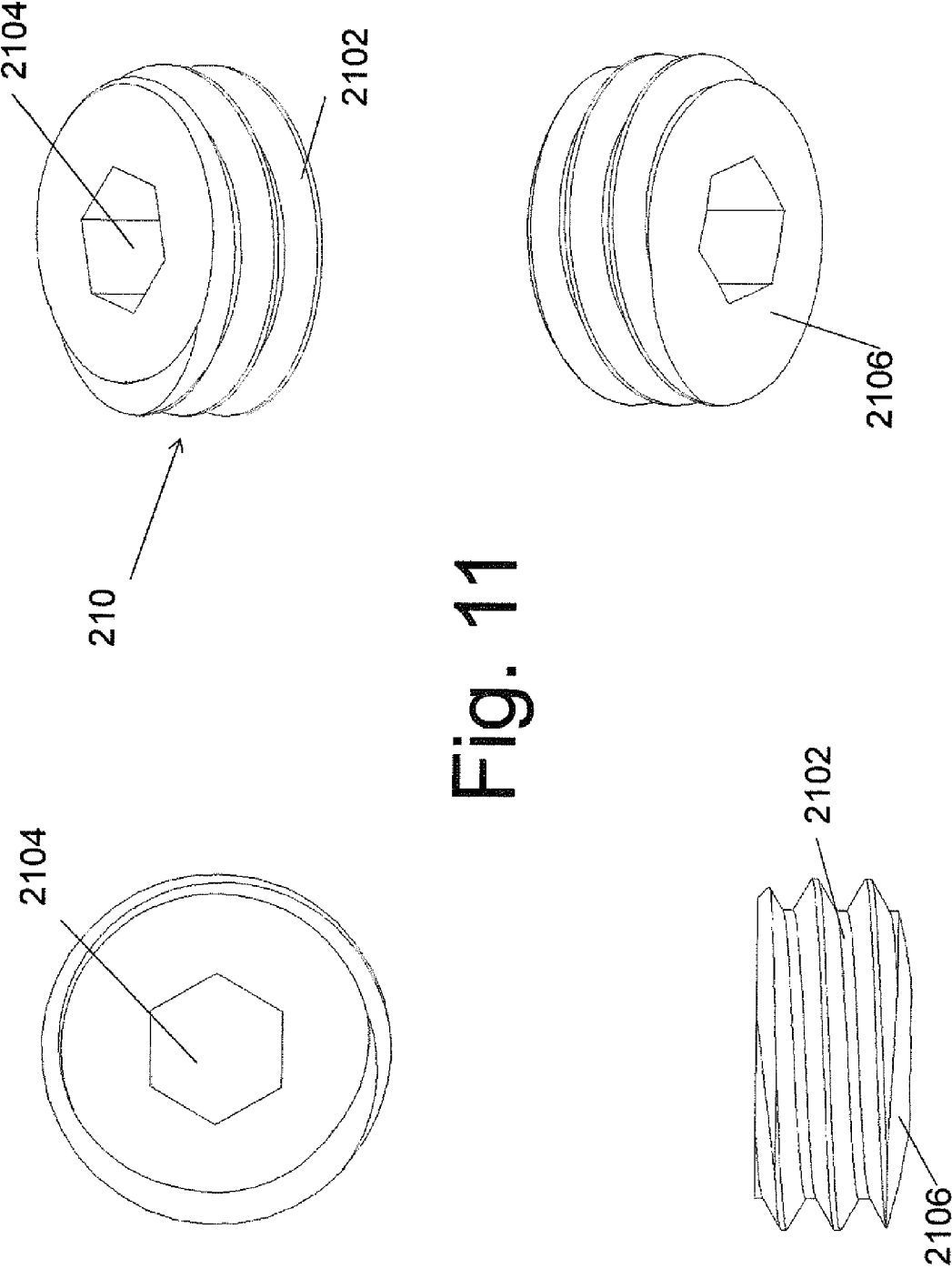

Fig. 11

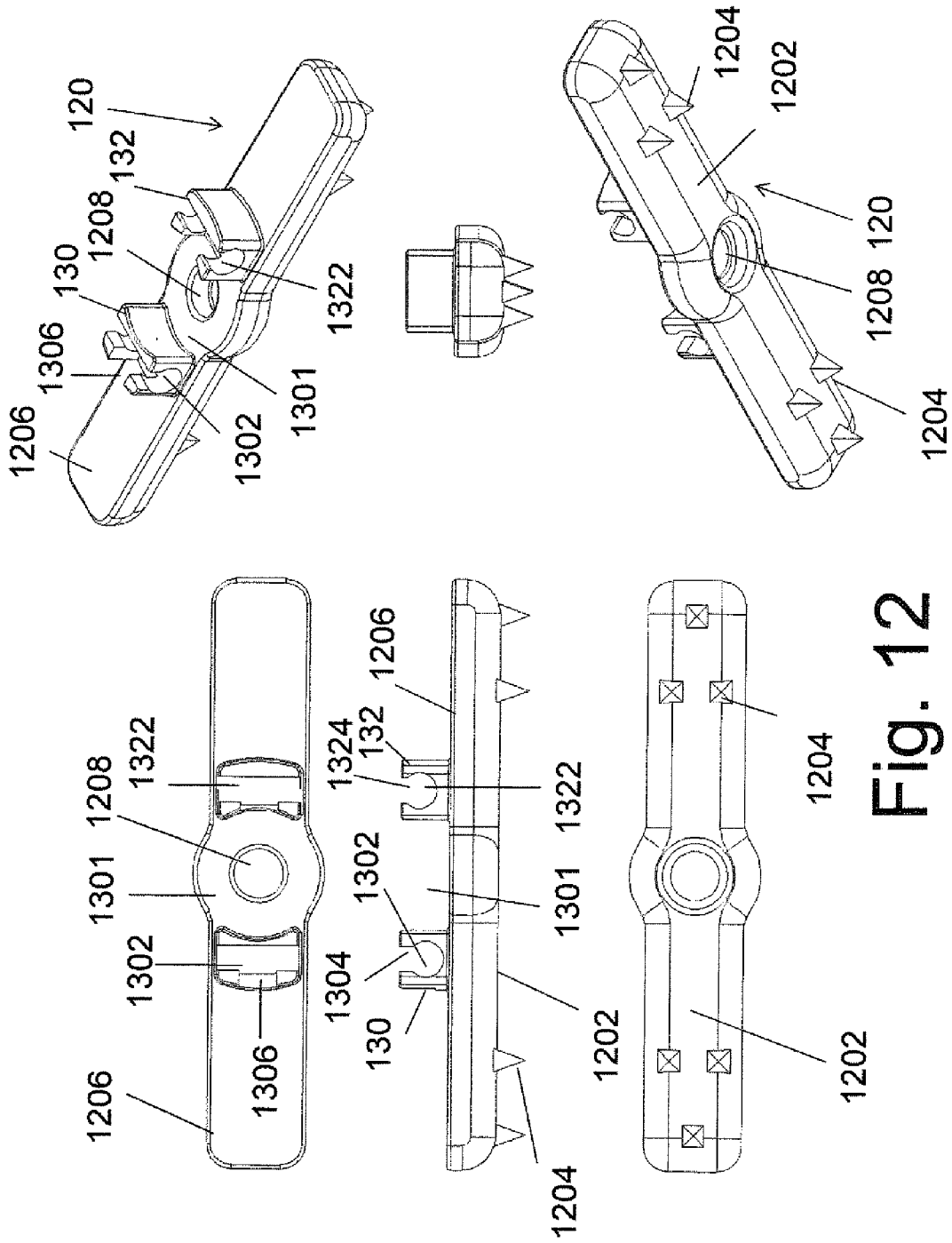

Fig. 12

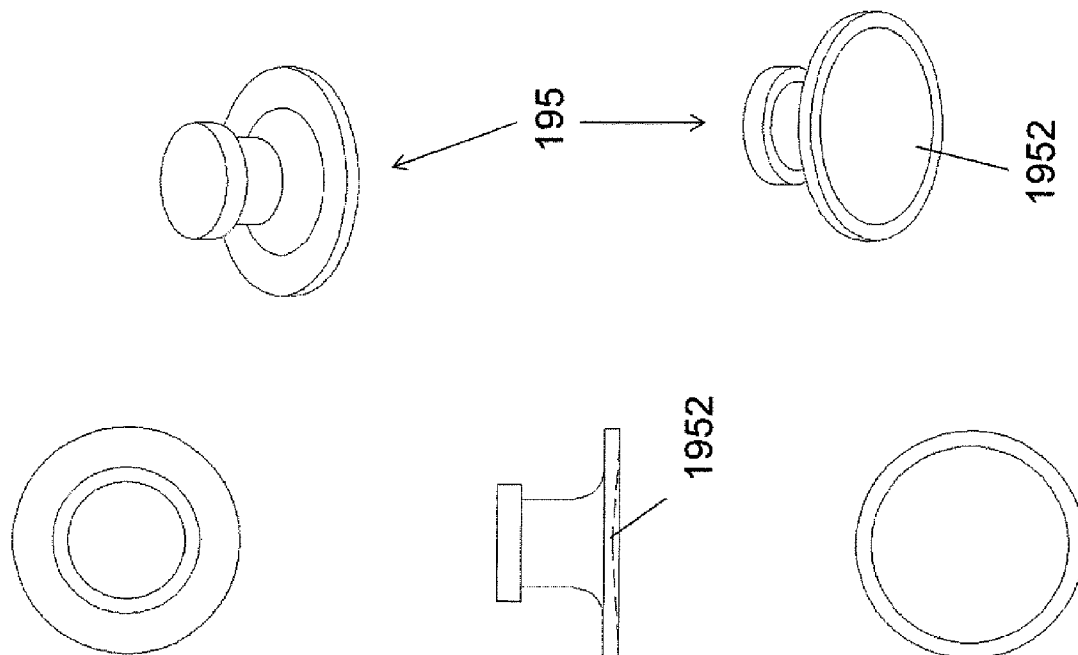

Fig. 13

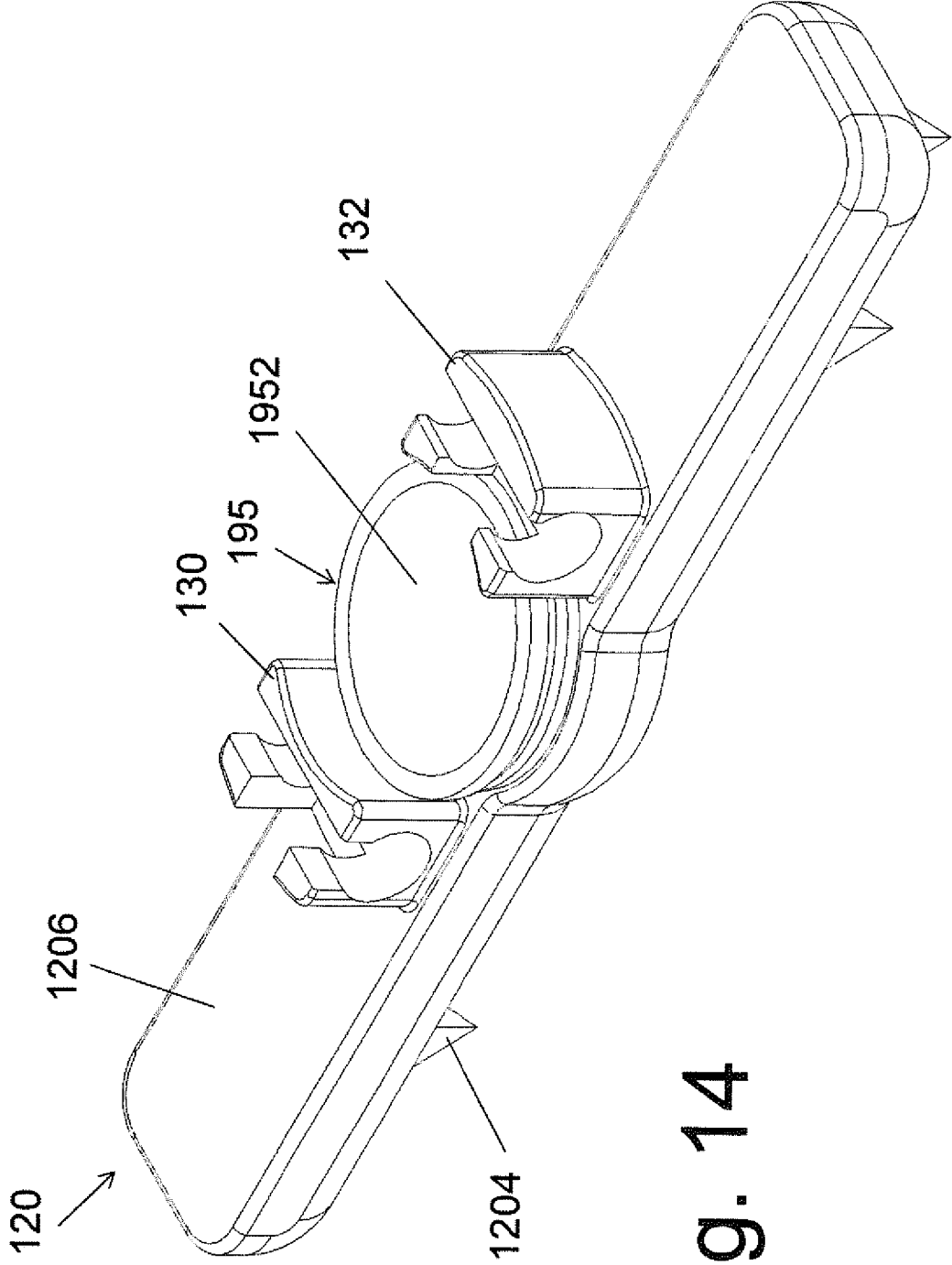
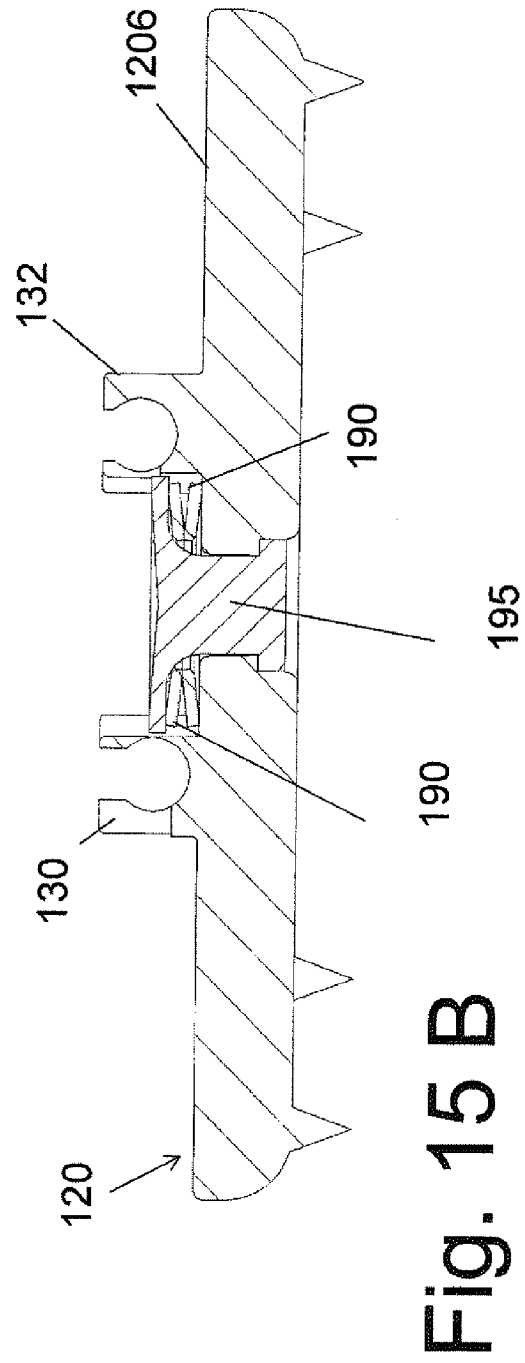
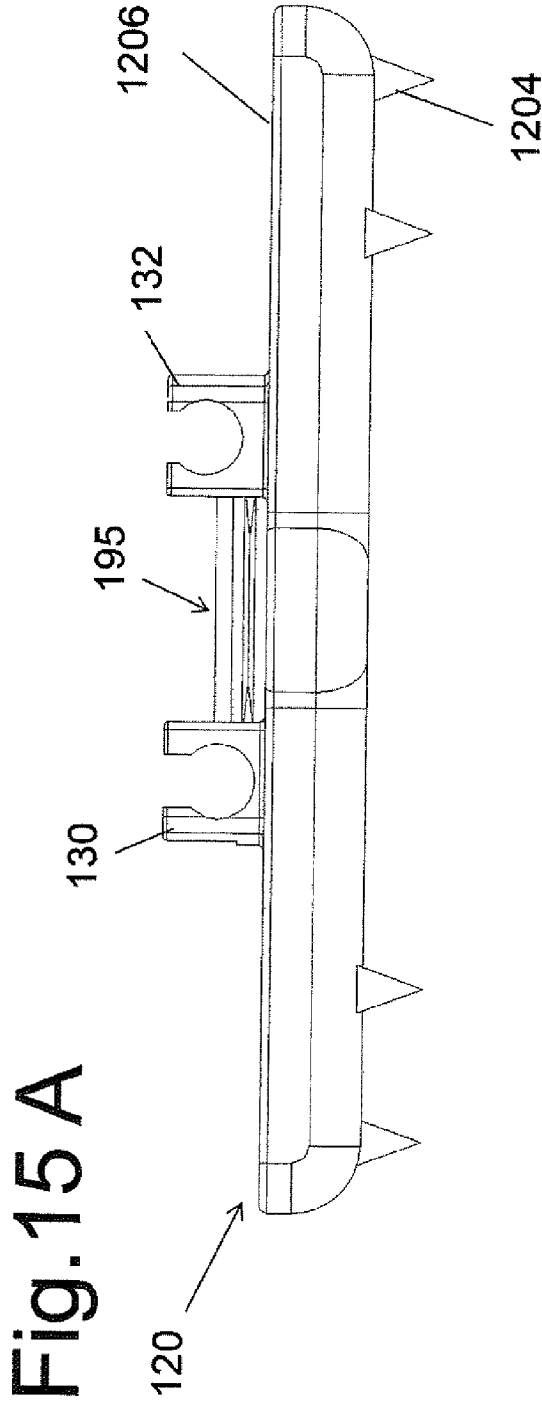

Fig. 14



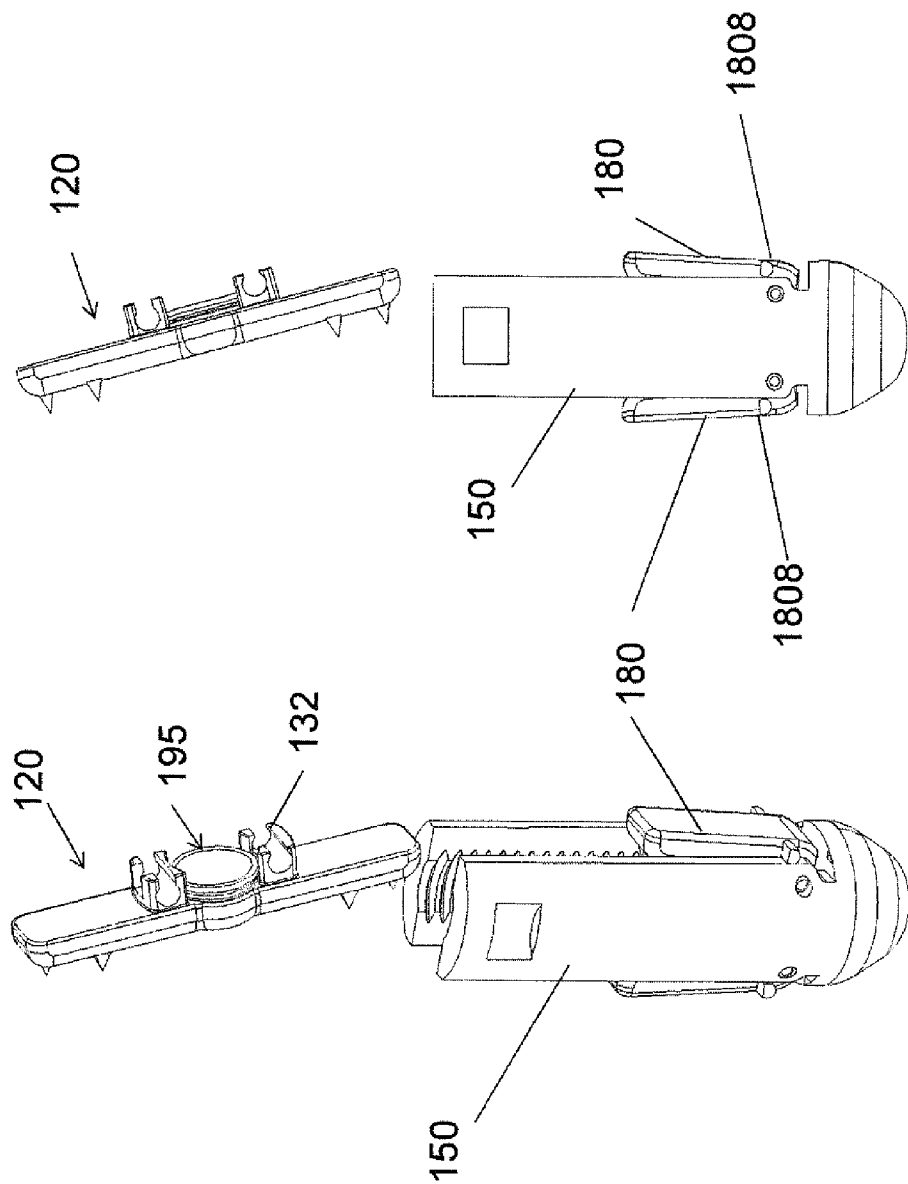
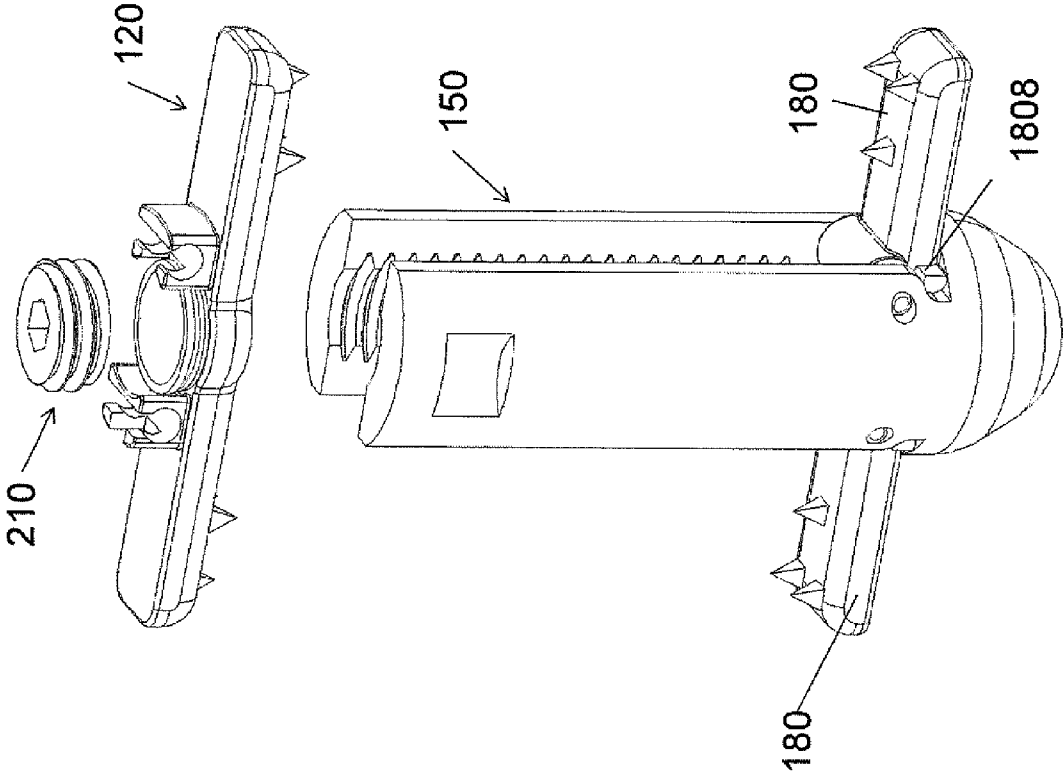

Fig. 16 A

Fig. 16 B

Fig. 17



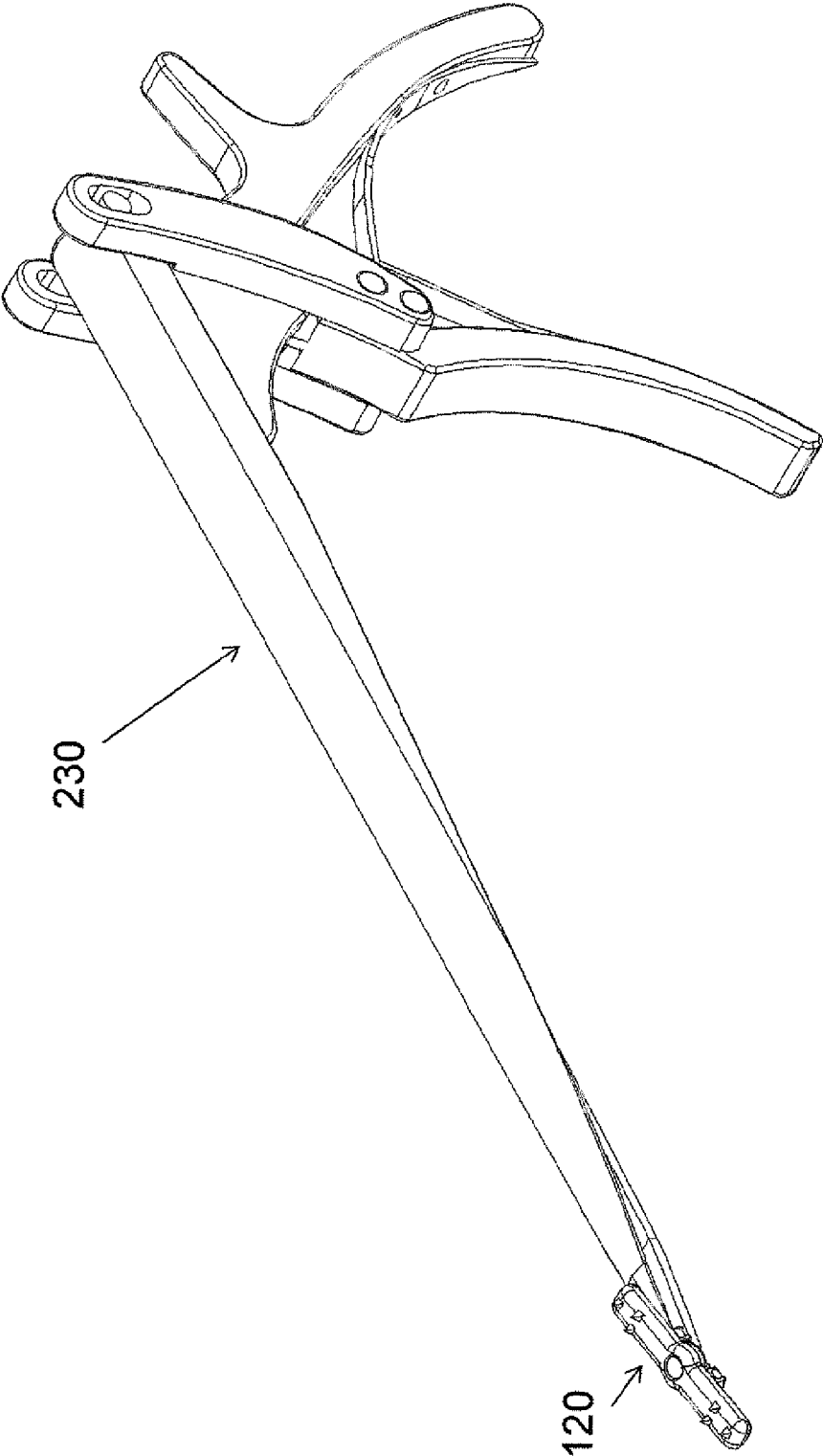

Fig. 18

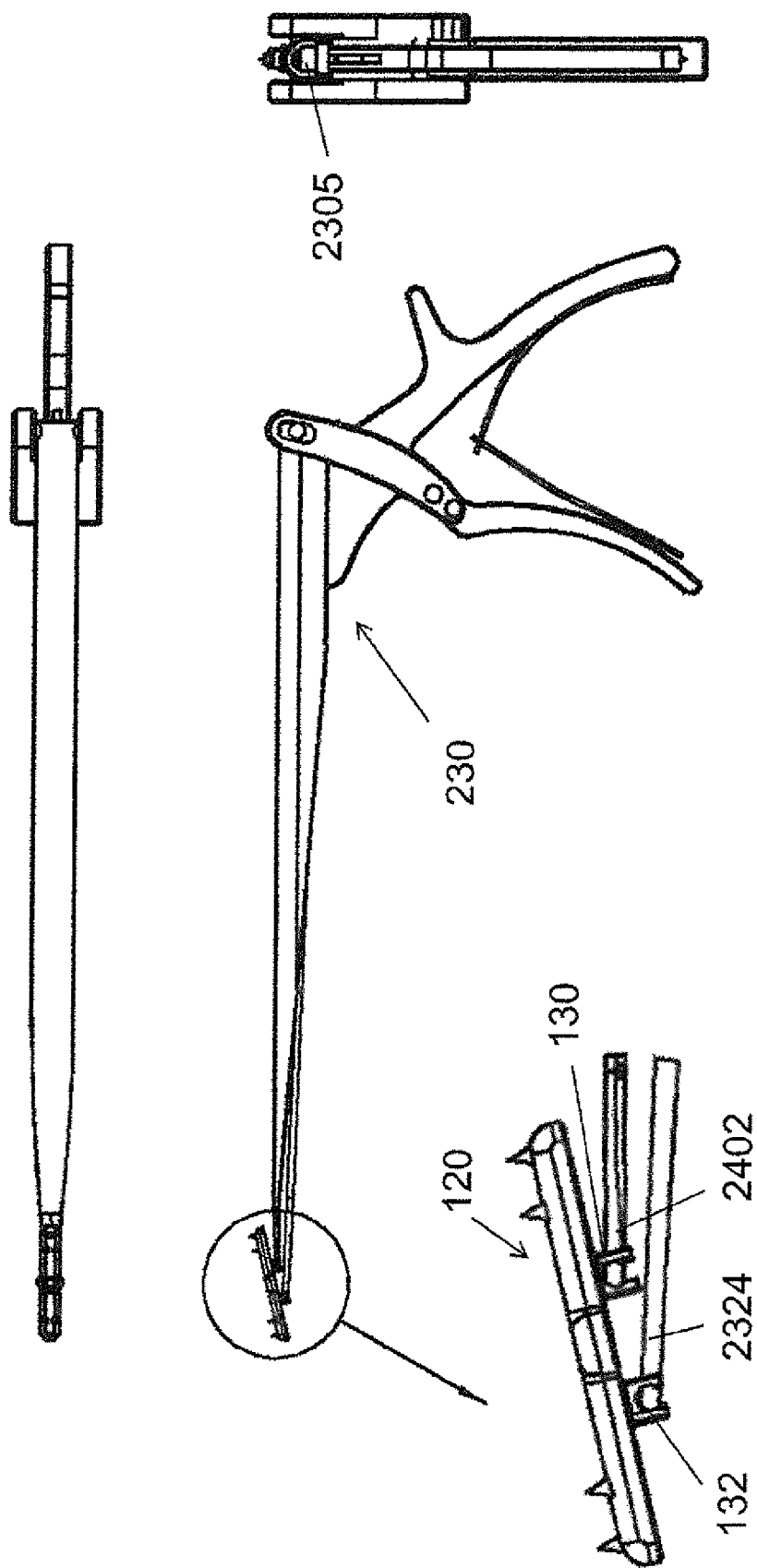

Fig. 19

Fig. 20

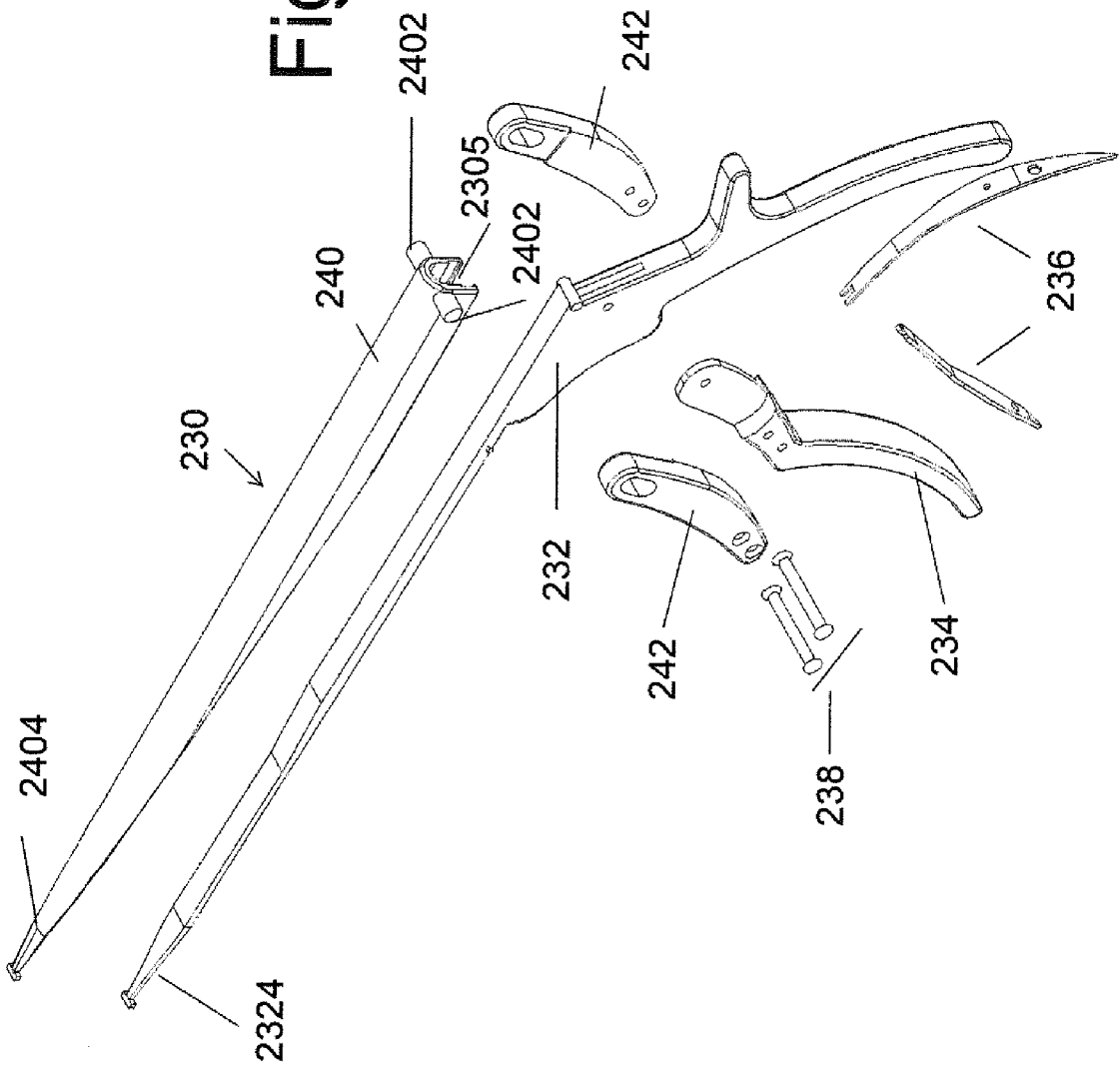
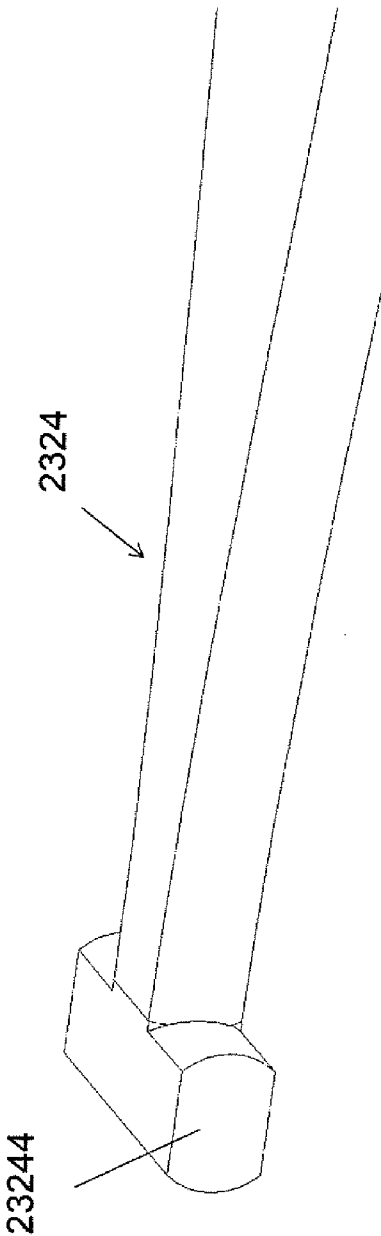
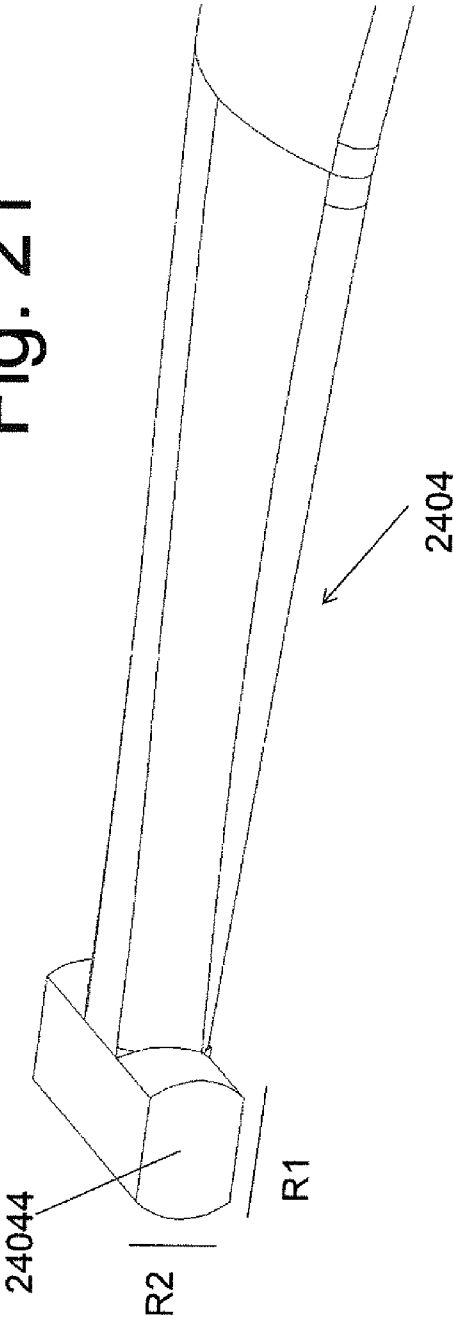

Fig. 21



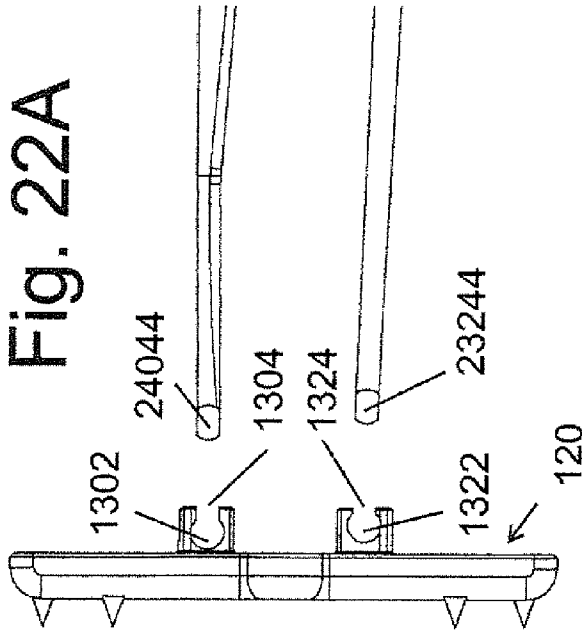

Fig. 22A

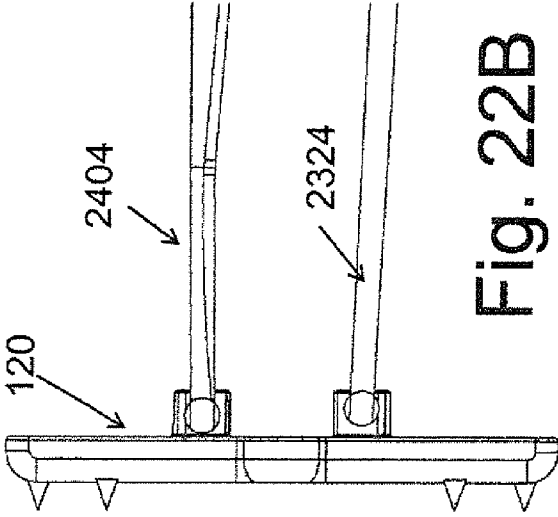

Fig. 22B

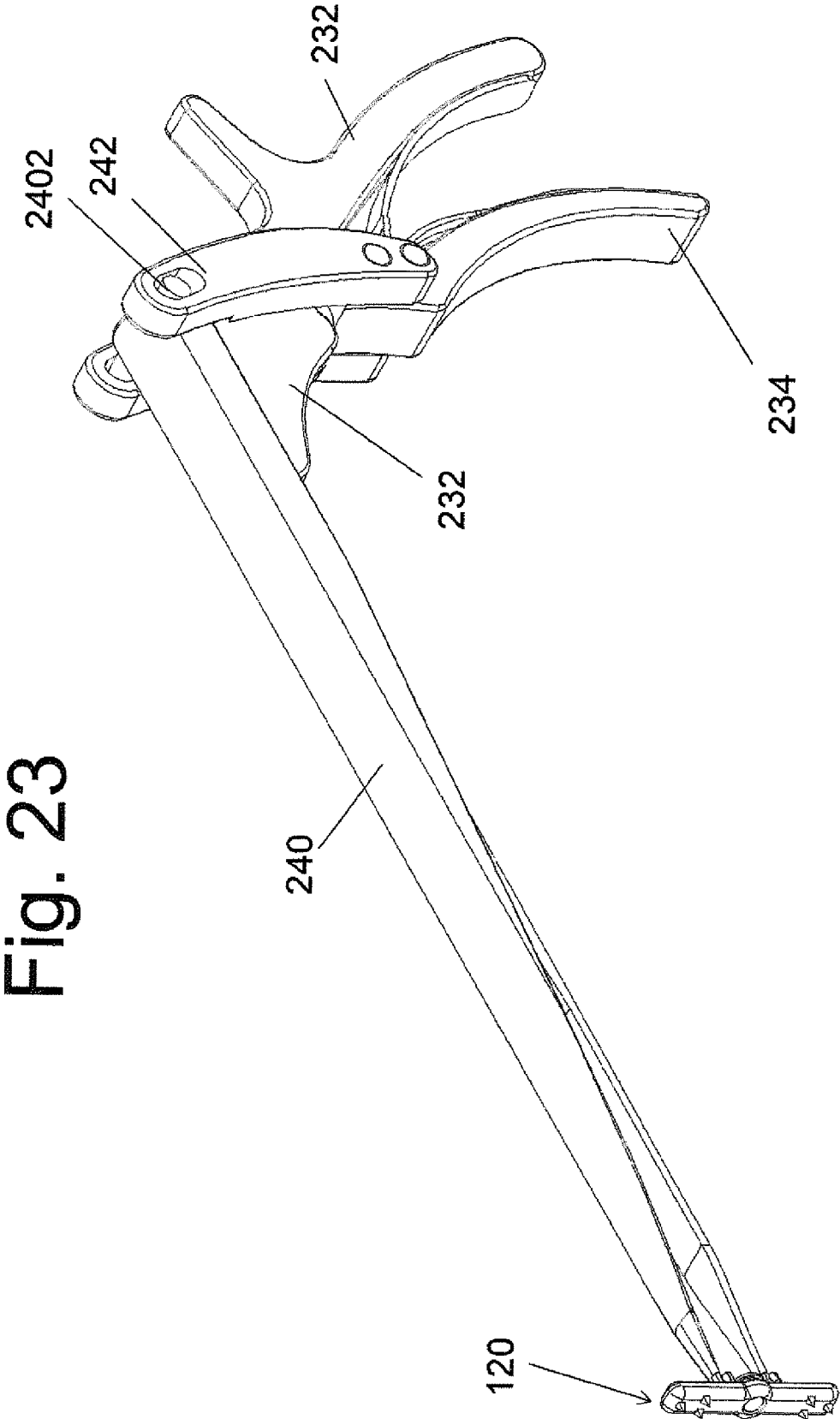

Fig. 23

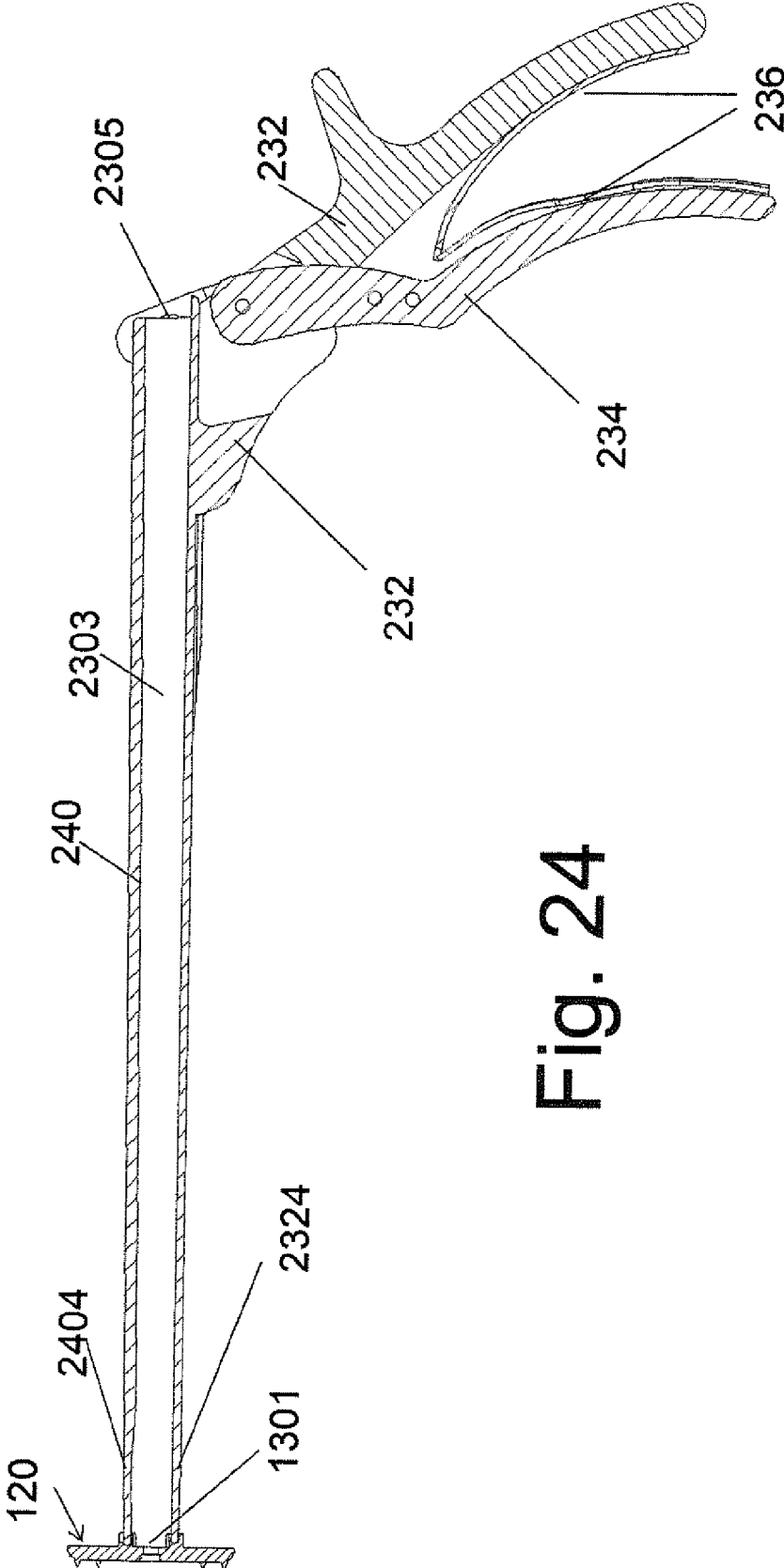

Fig. 24

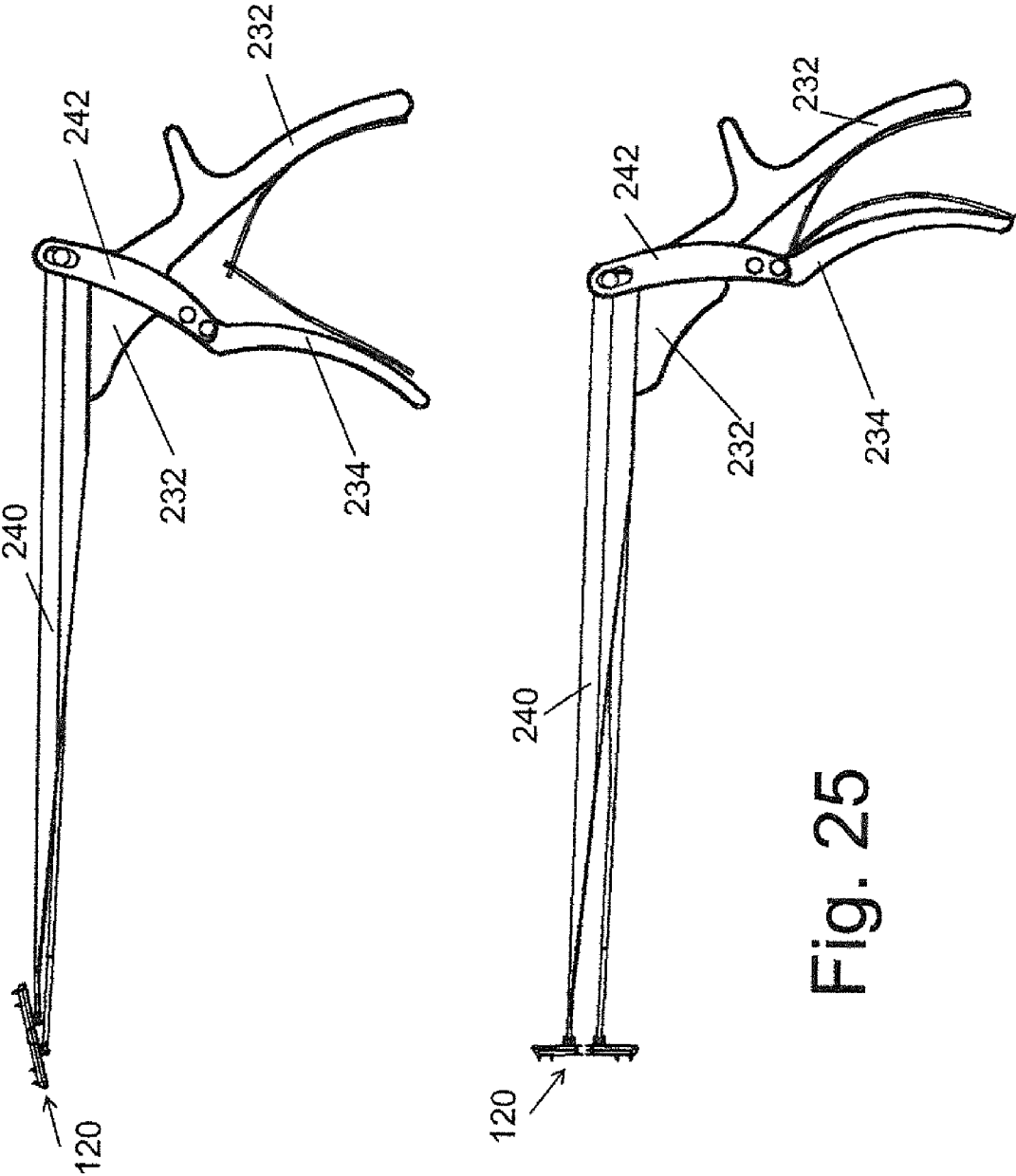

Fig. 25

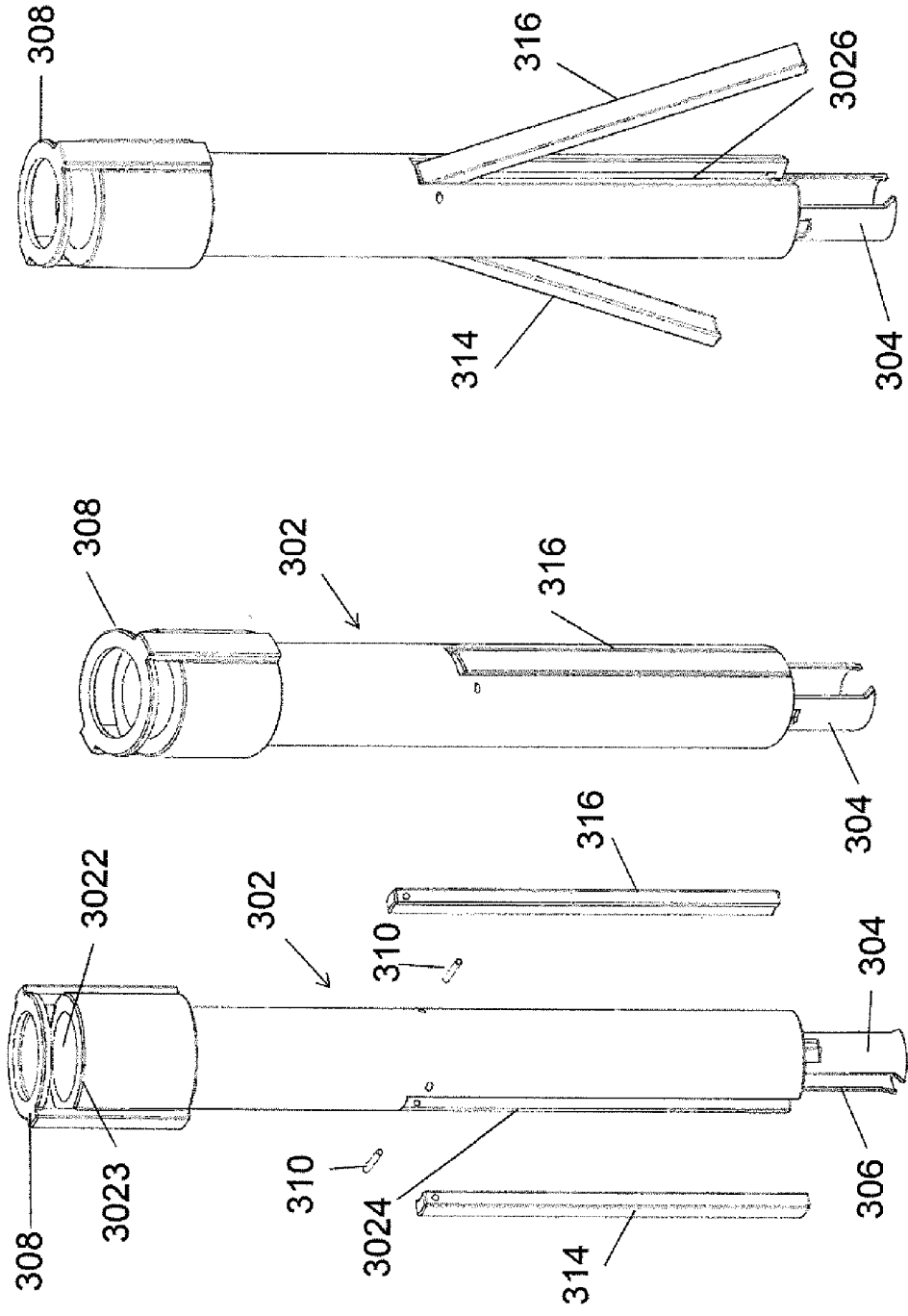

Fig. 26C

Fig. 26B

Fig. 26A

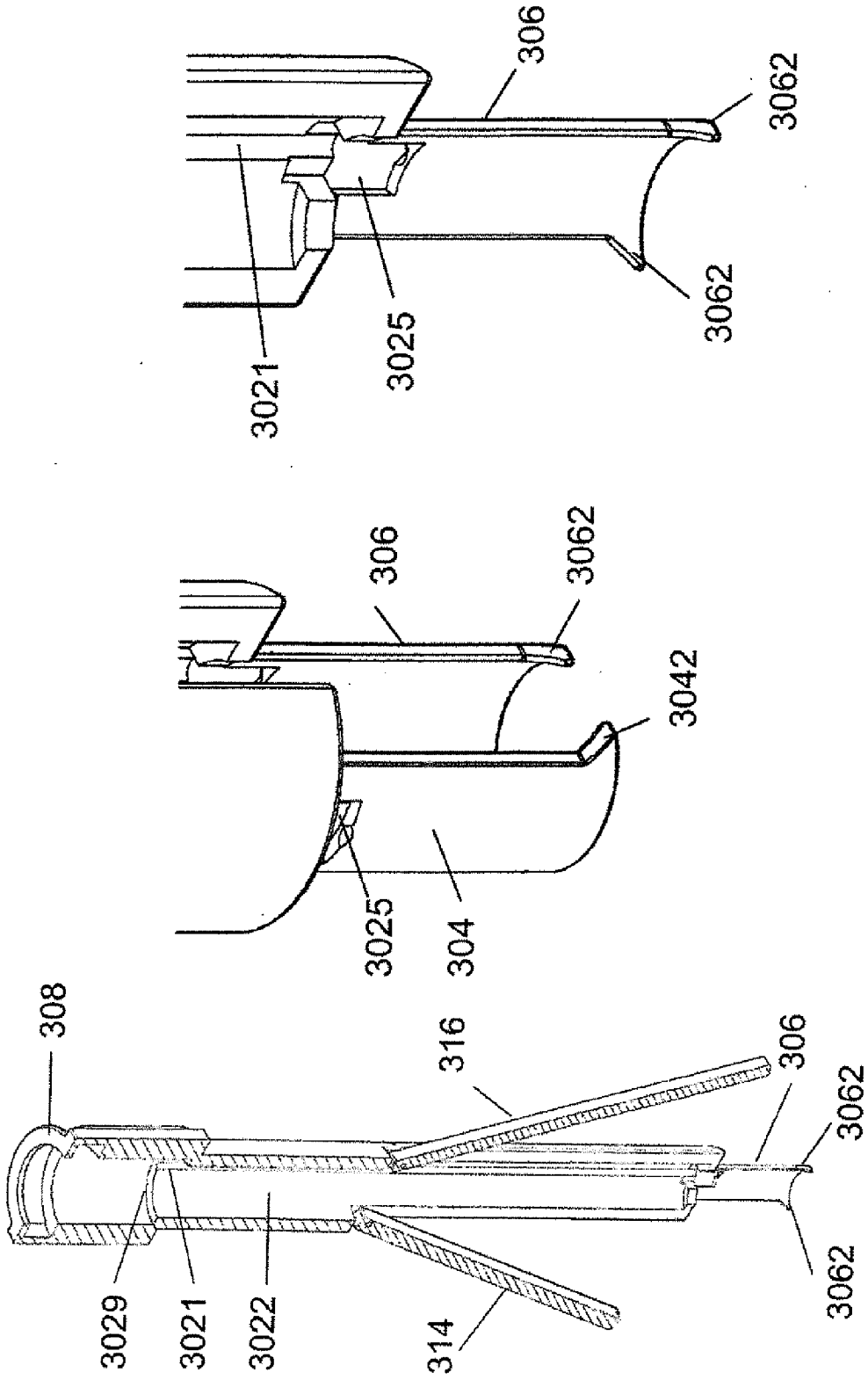
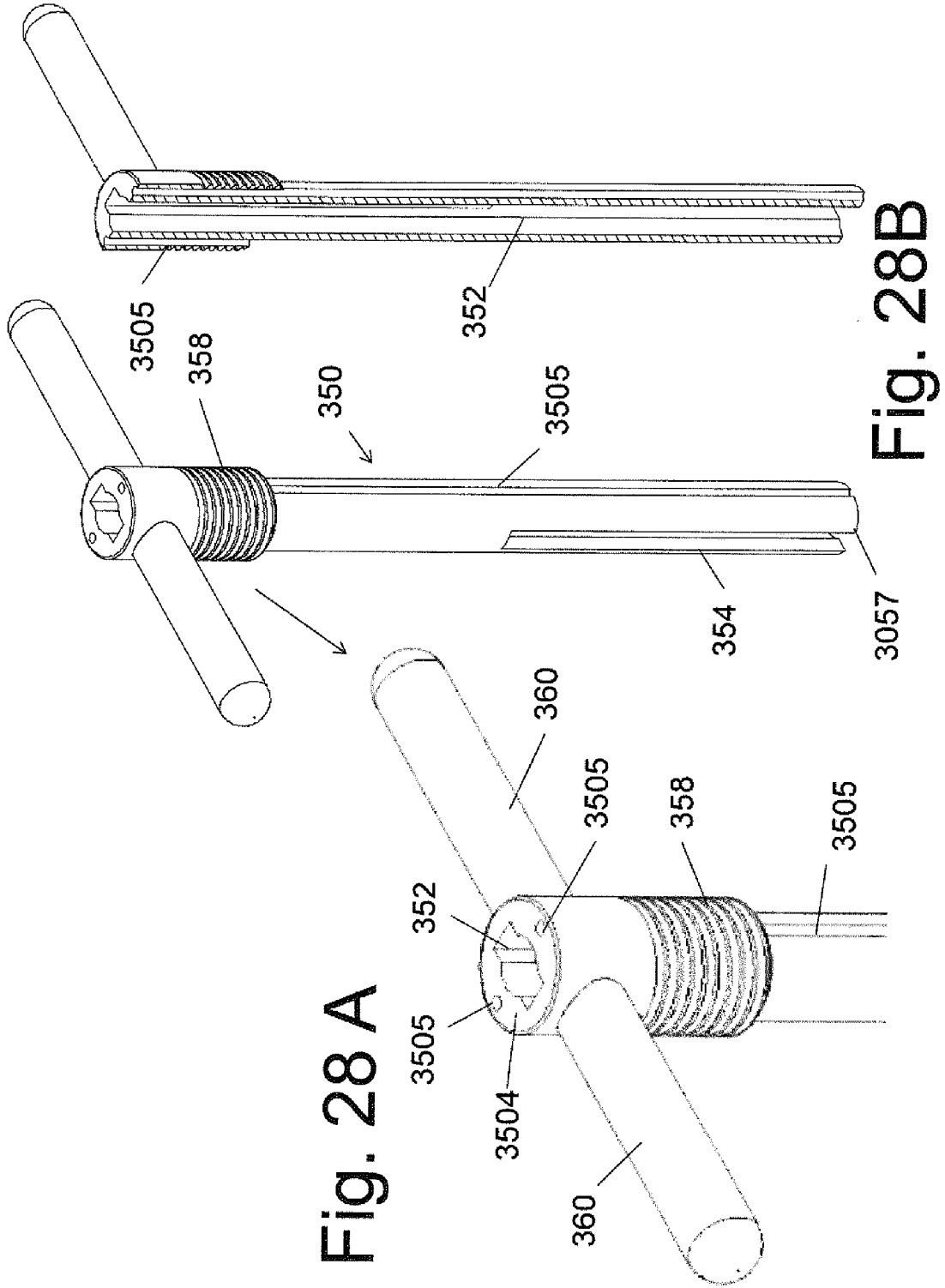

Fig. 27B

Fig. 27A



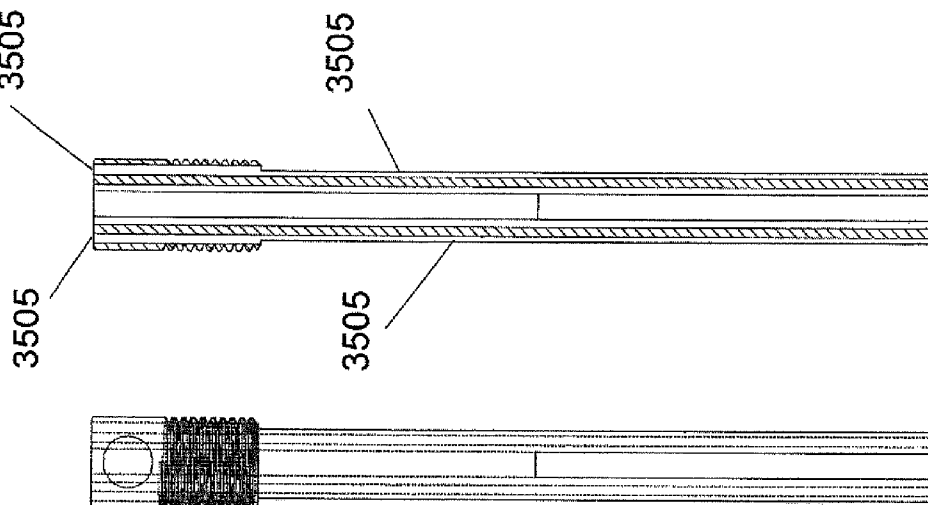
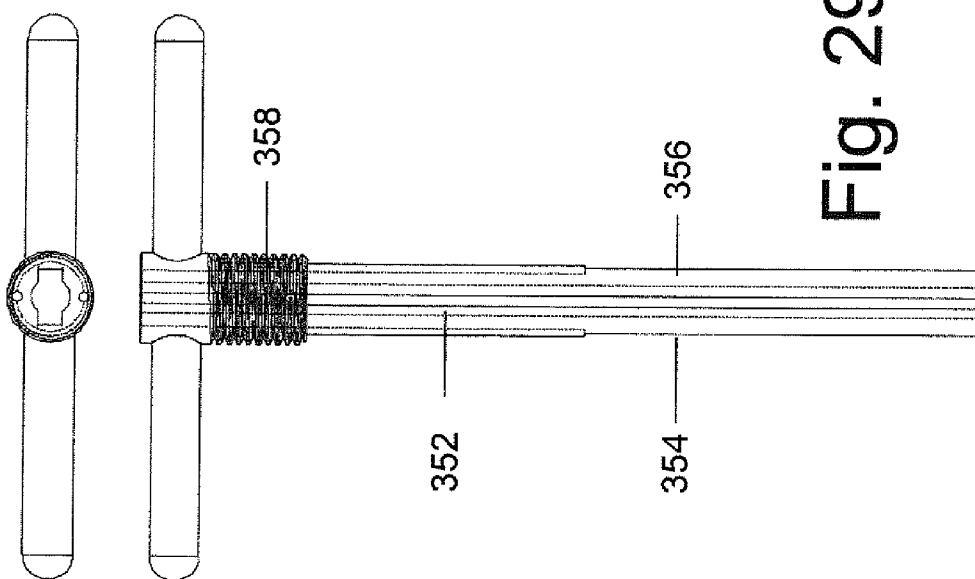

Fig. 30

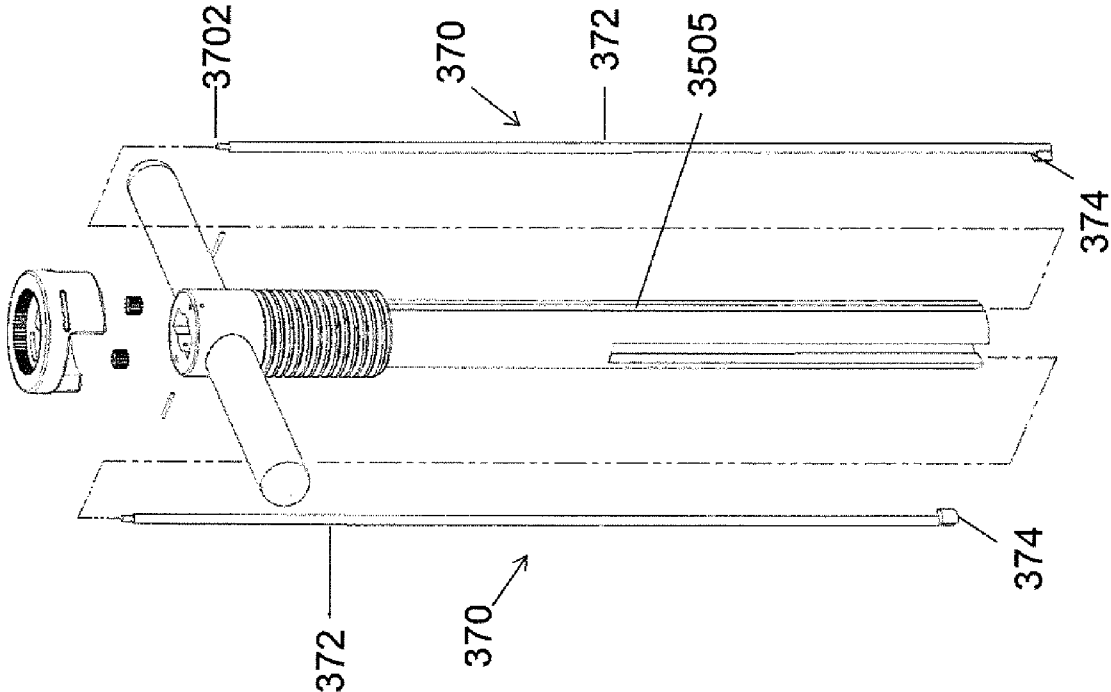

Fig. 31

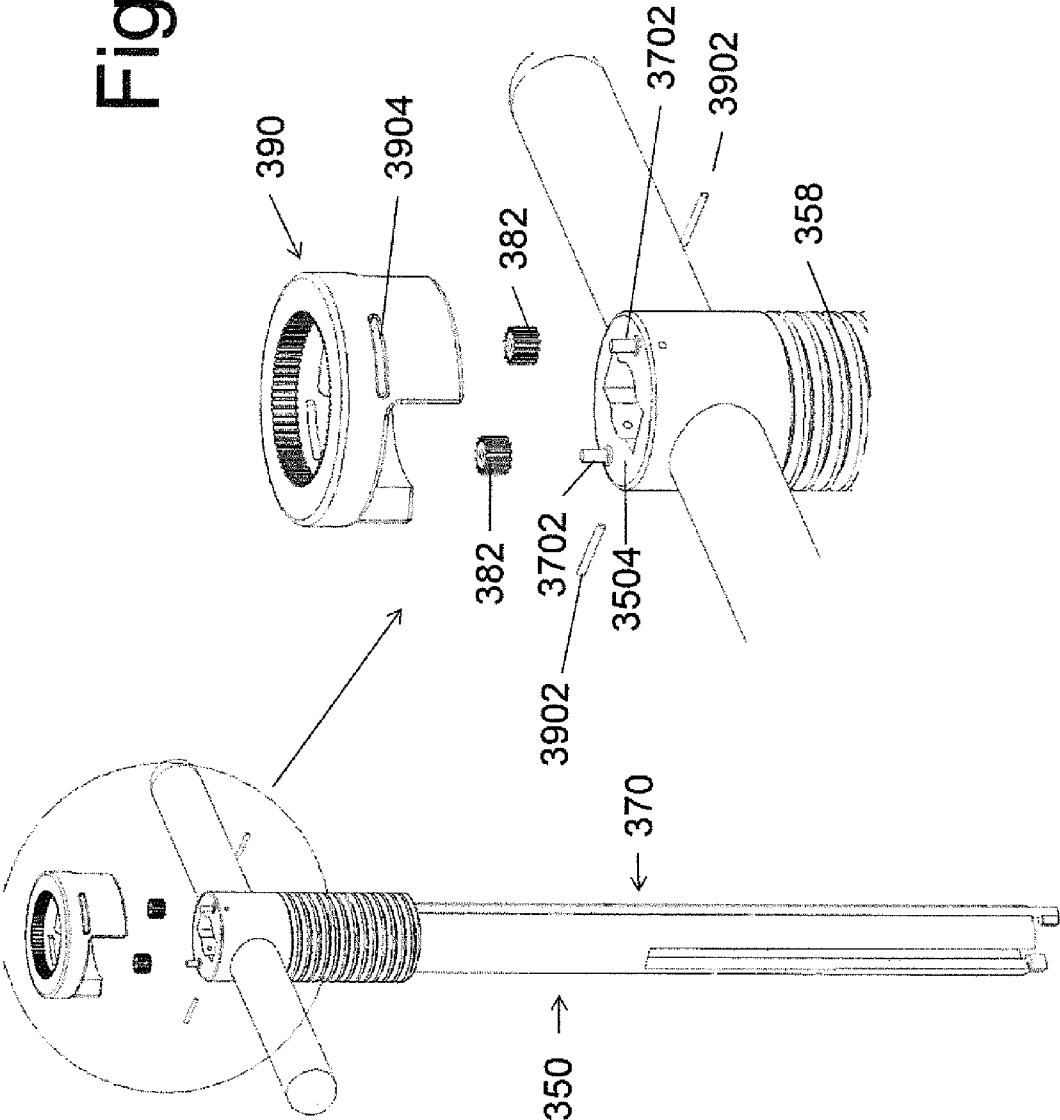

Fig. 32

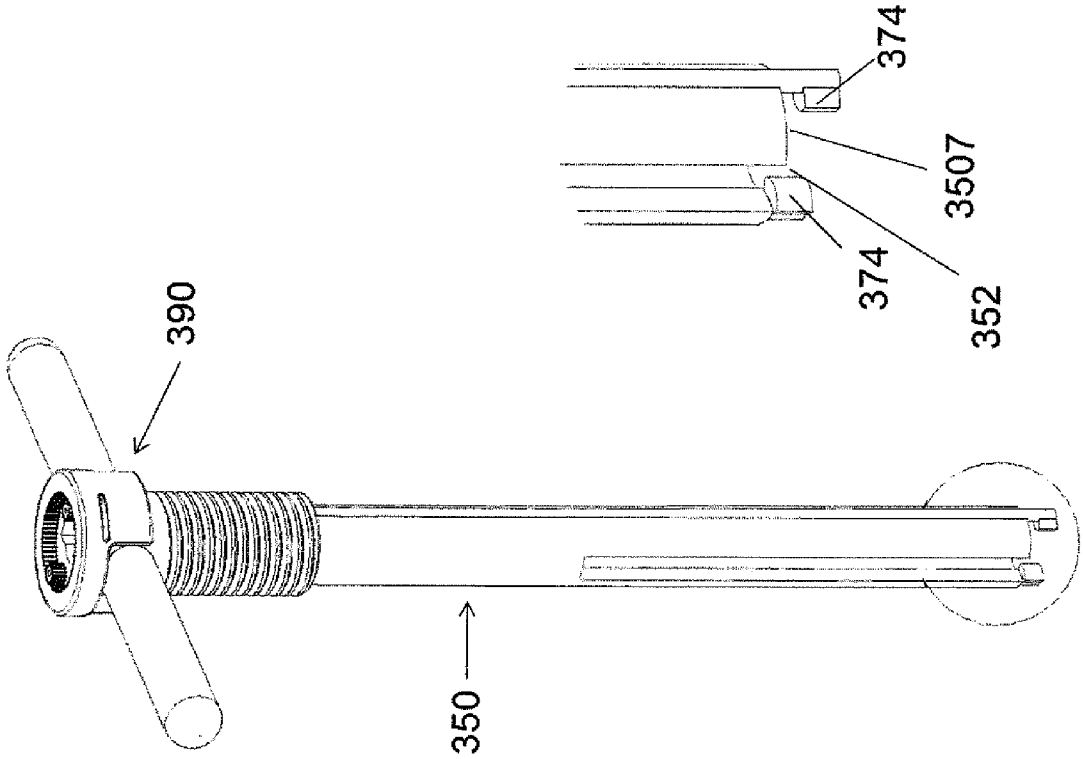

Fig. 33

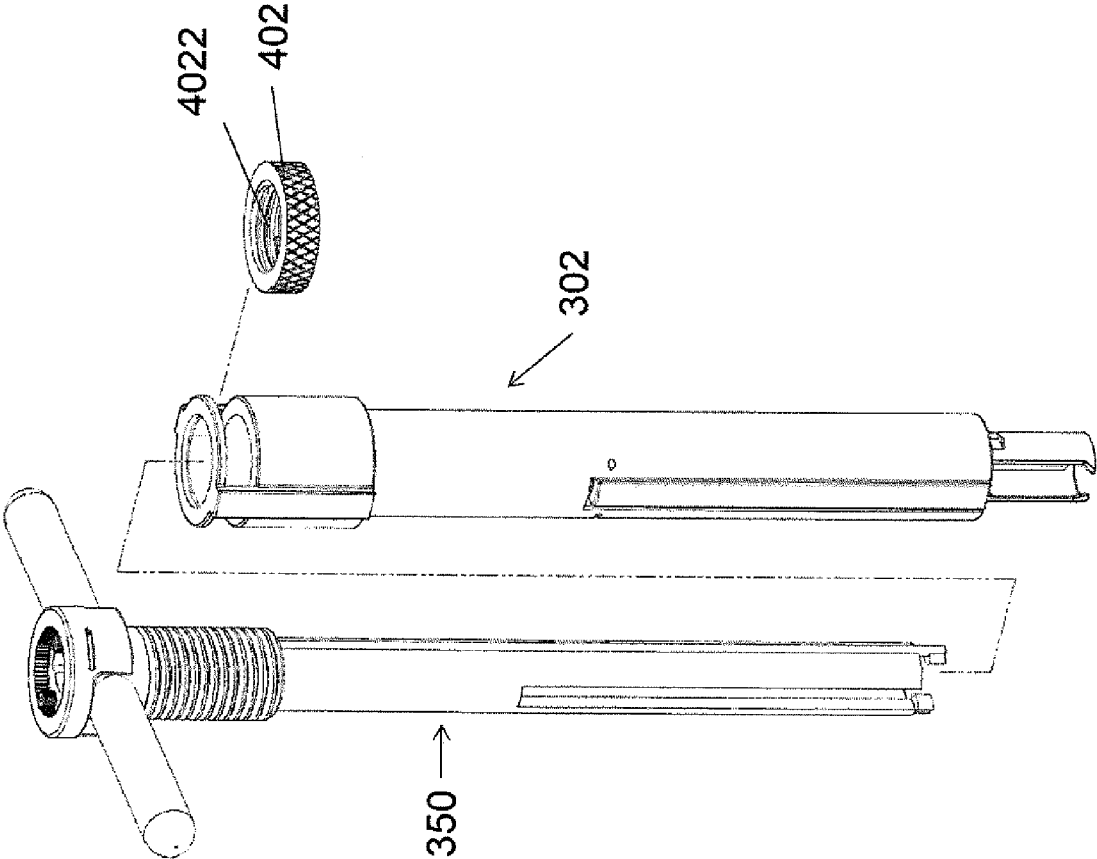

Fig. 34

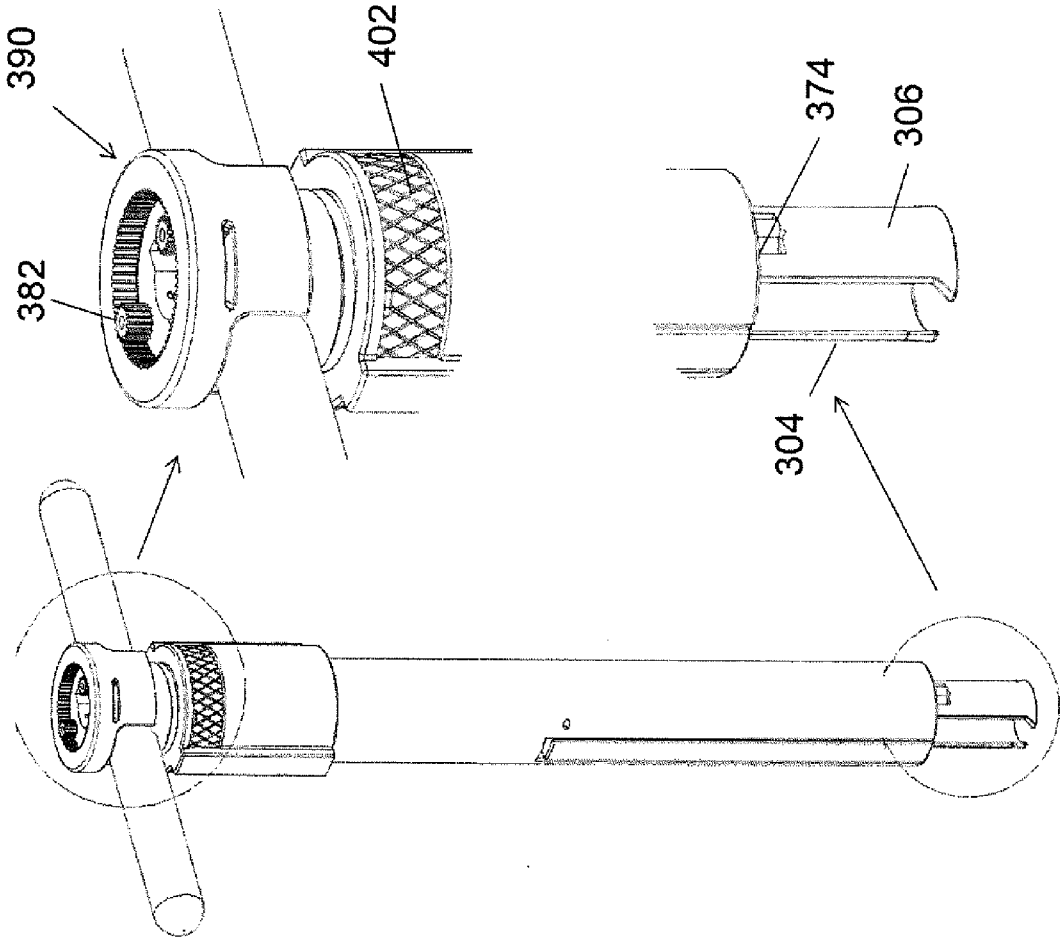
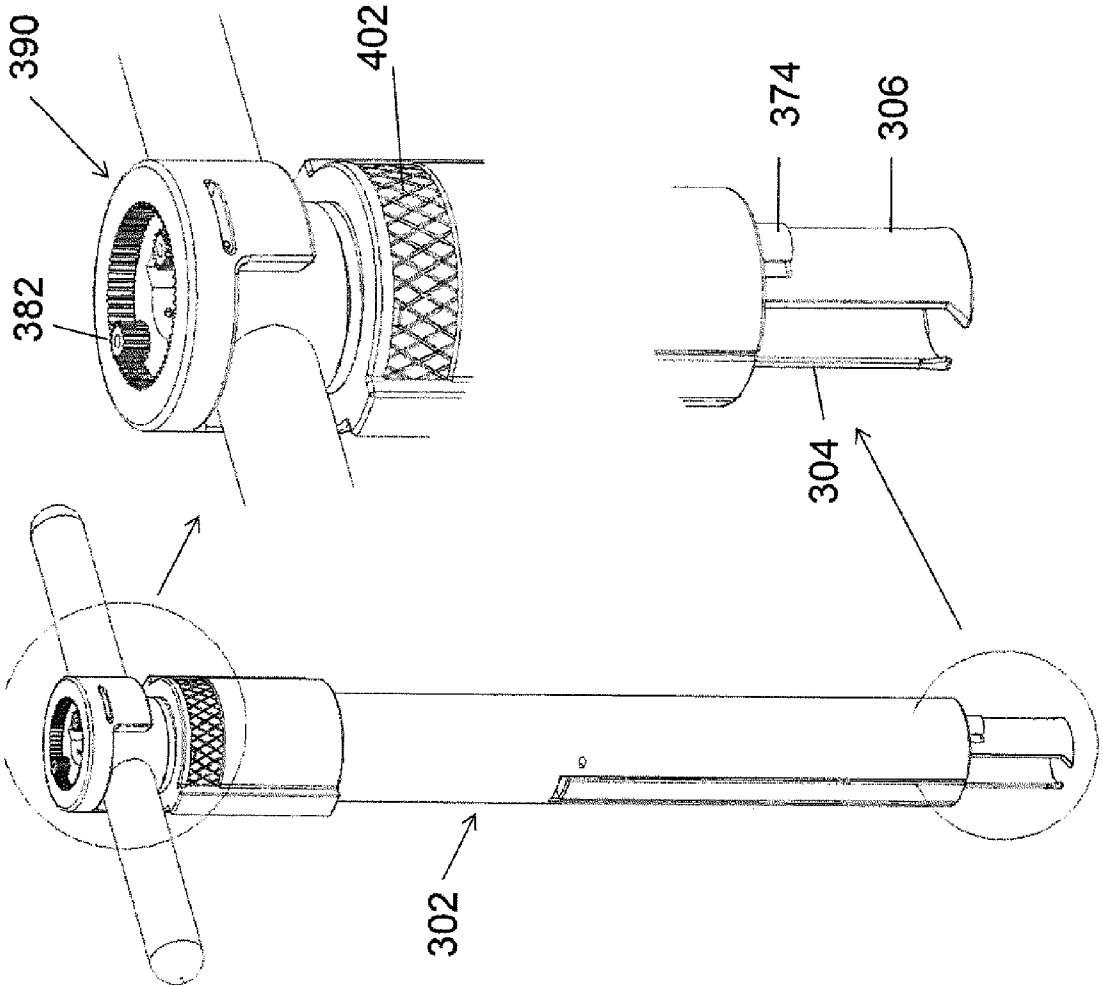

Fig. 35



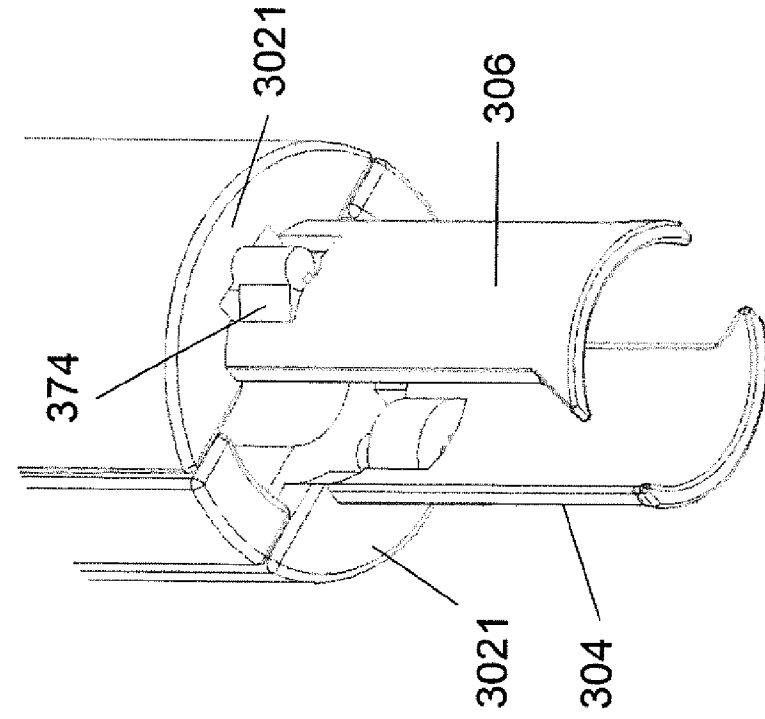

Fig. 36A

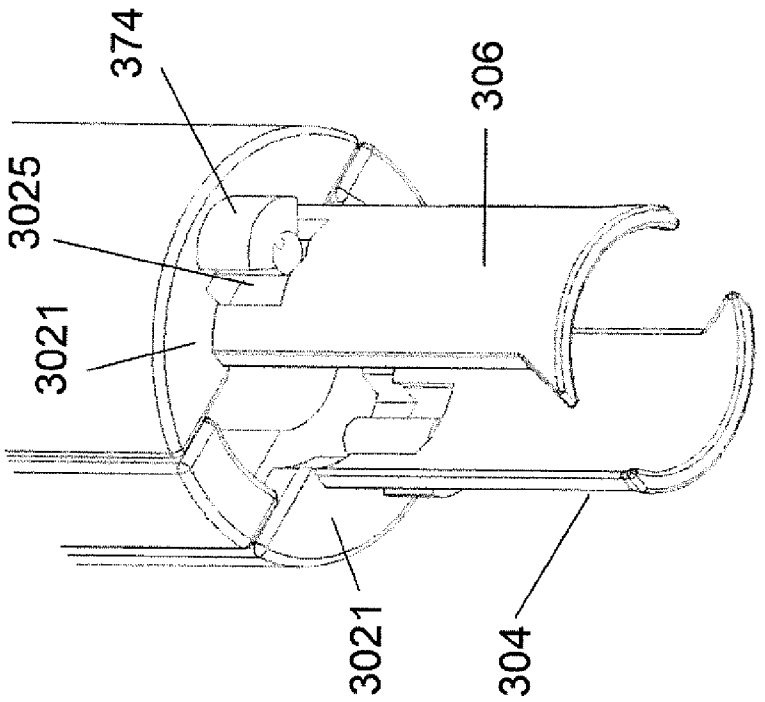

Fig. 36B

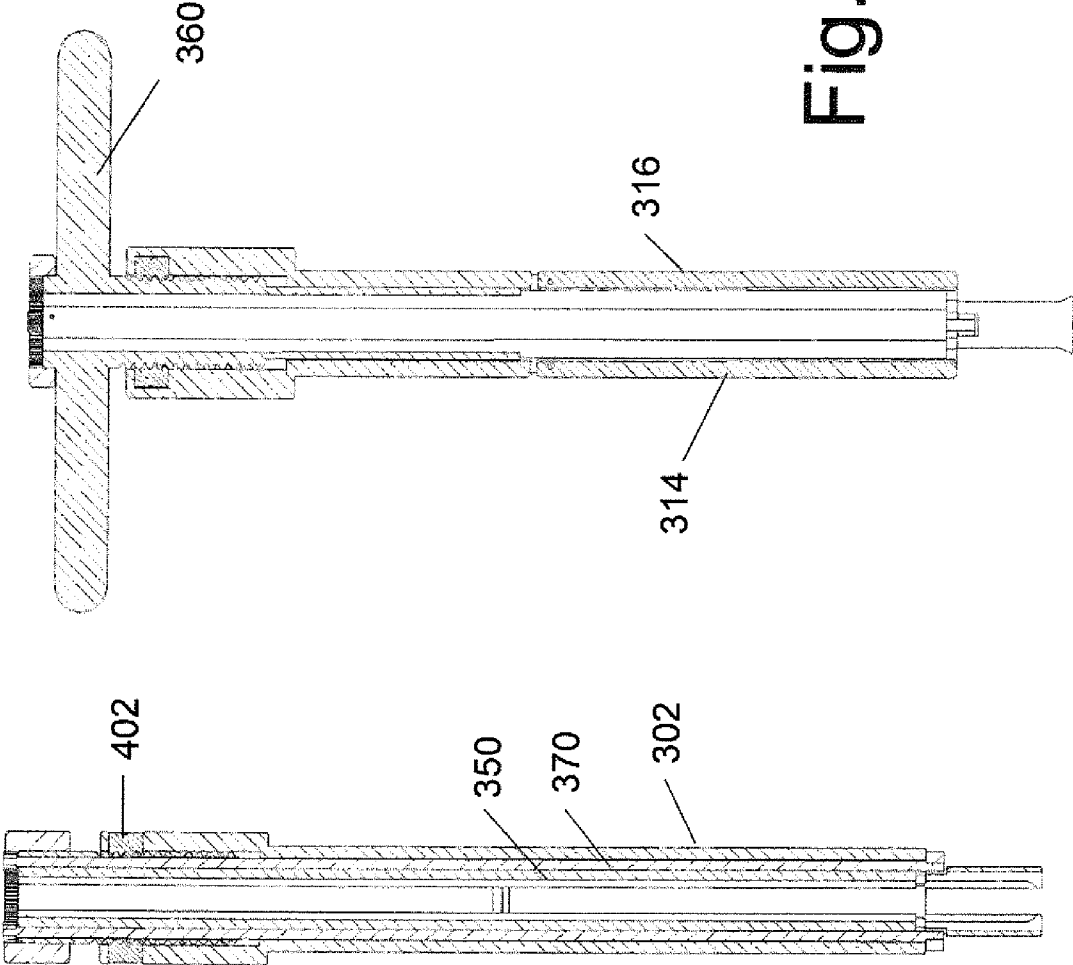

Fig. 37

Fig. 38

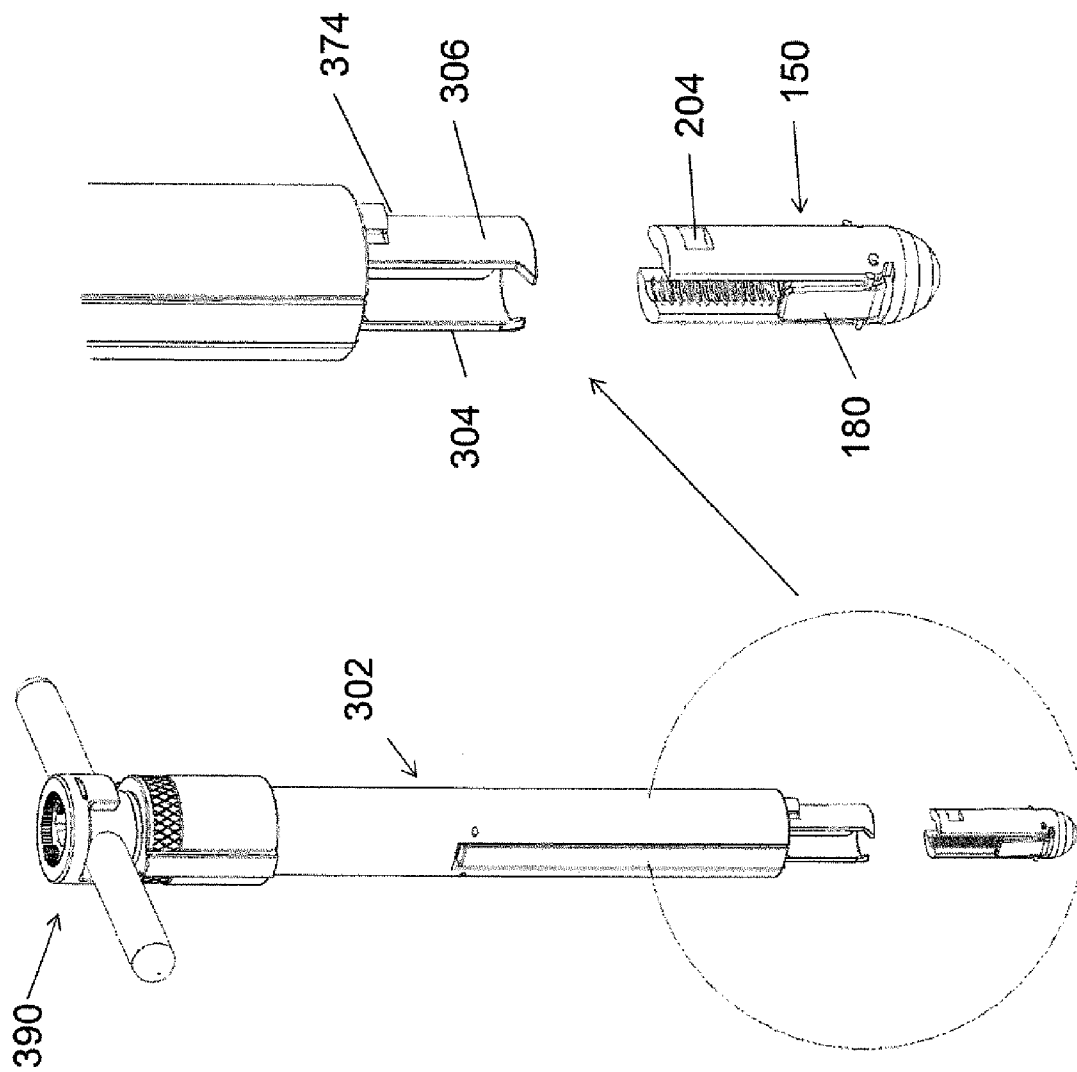
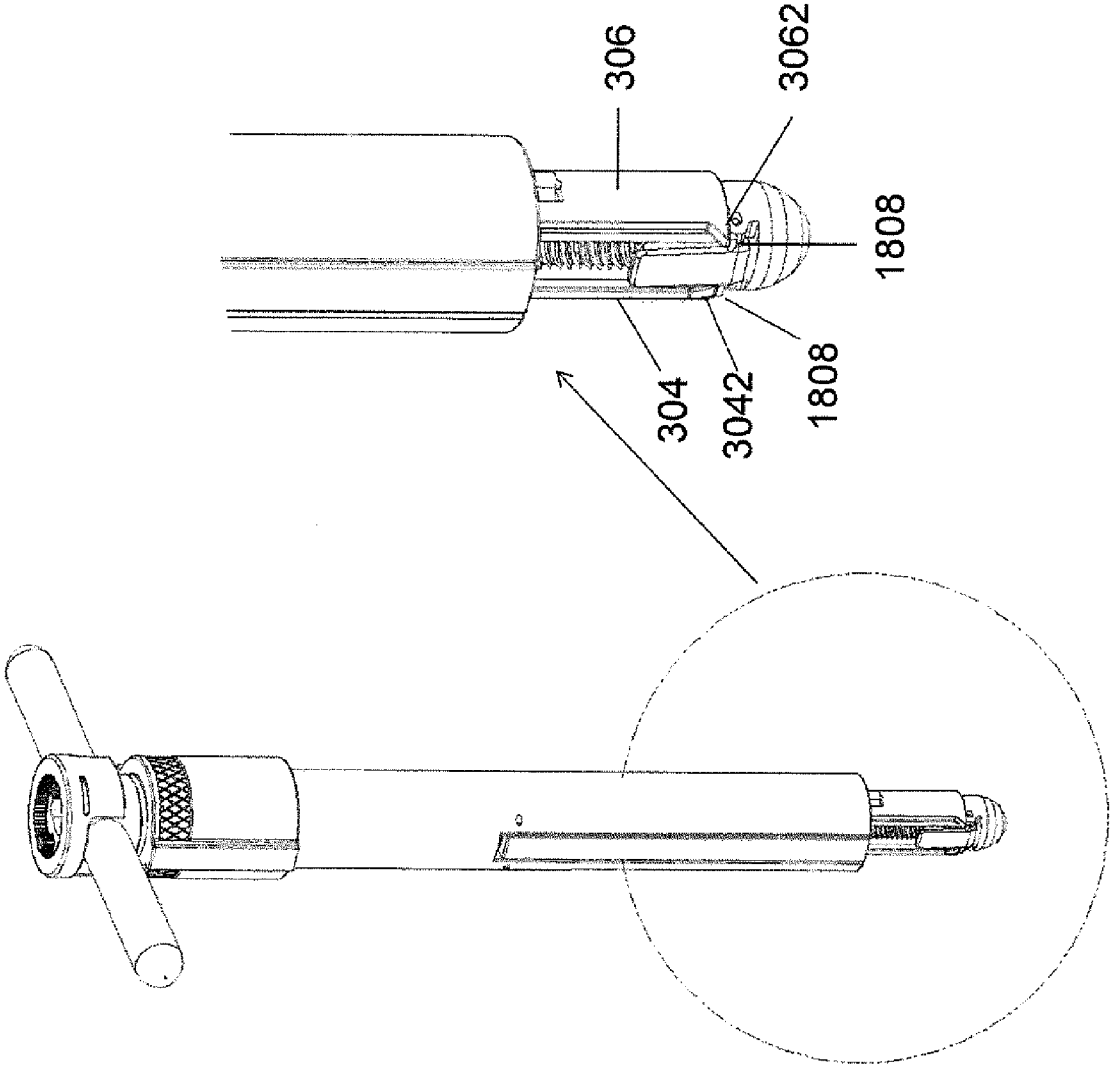

Fig. 39



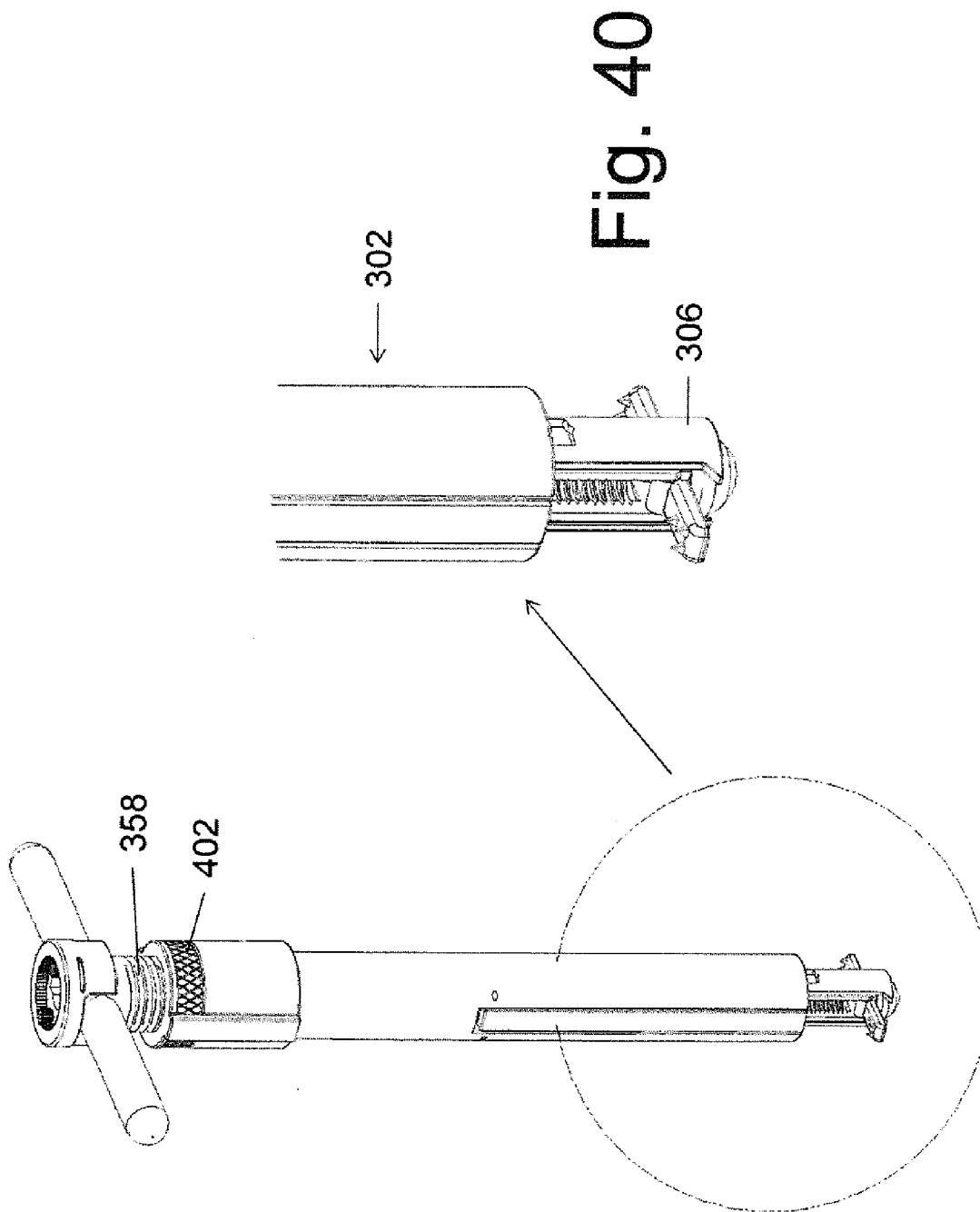

Fig. 40

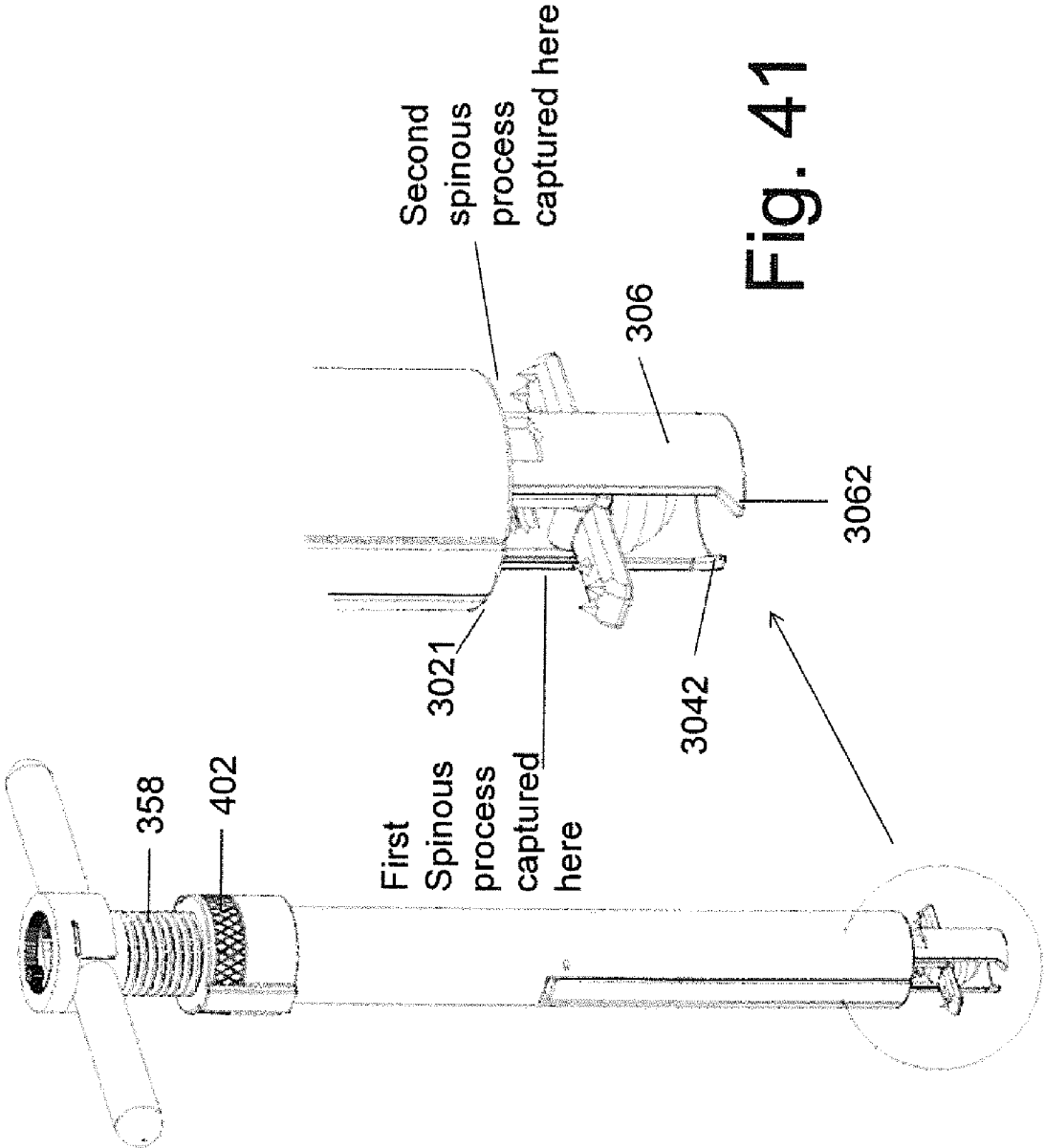

Fig. 41

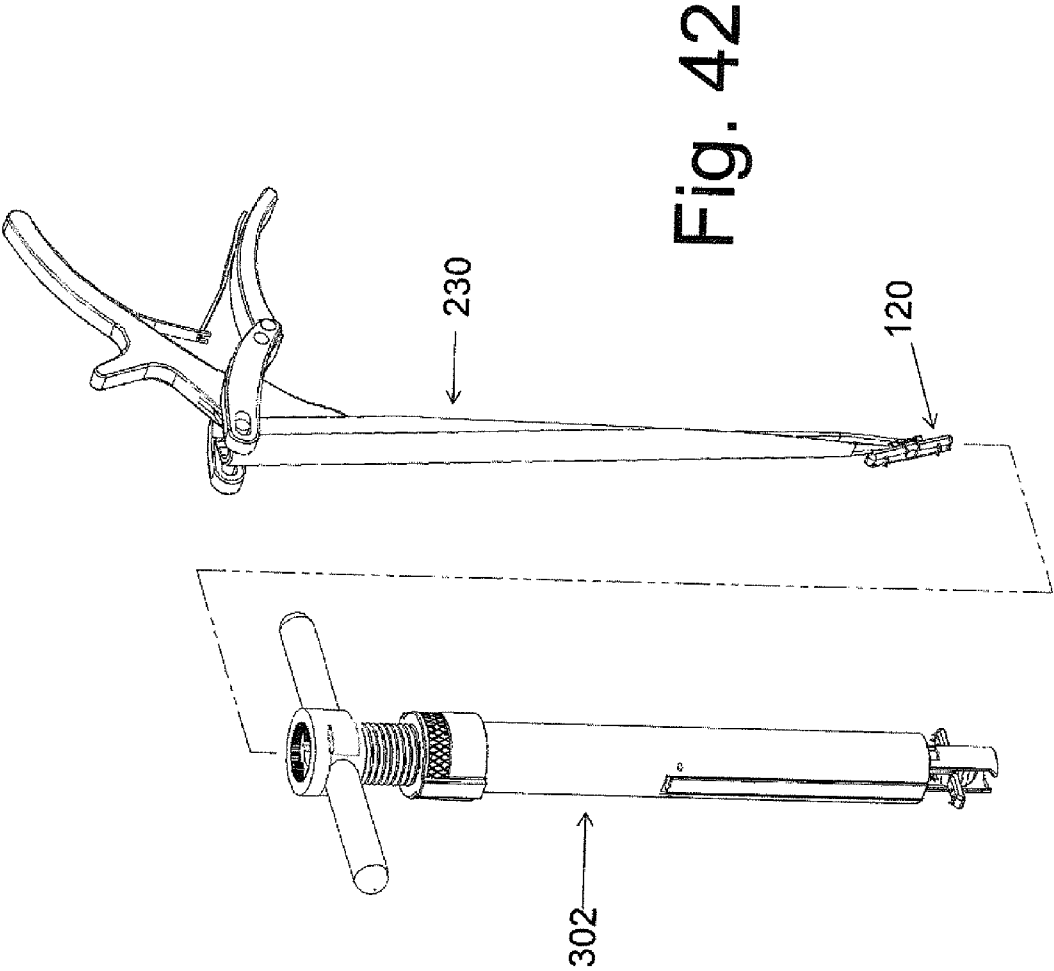

Fig. 42

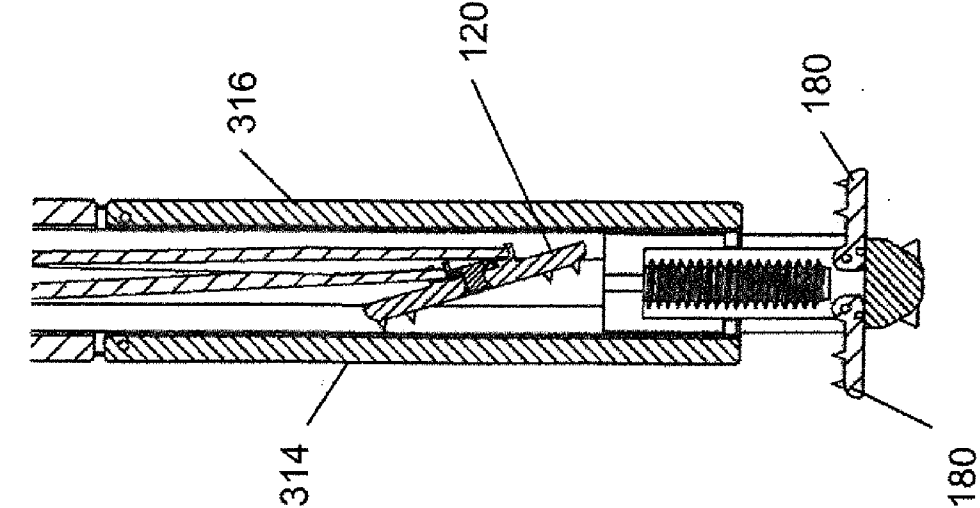

Fig. 43B

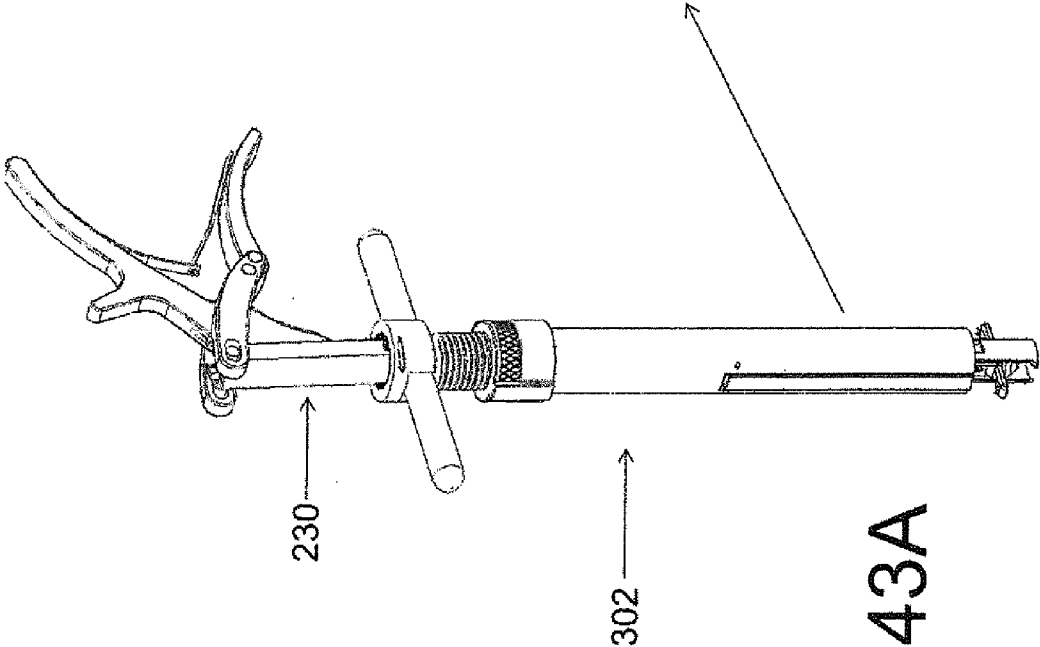

Fig. 43A

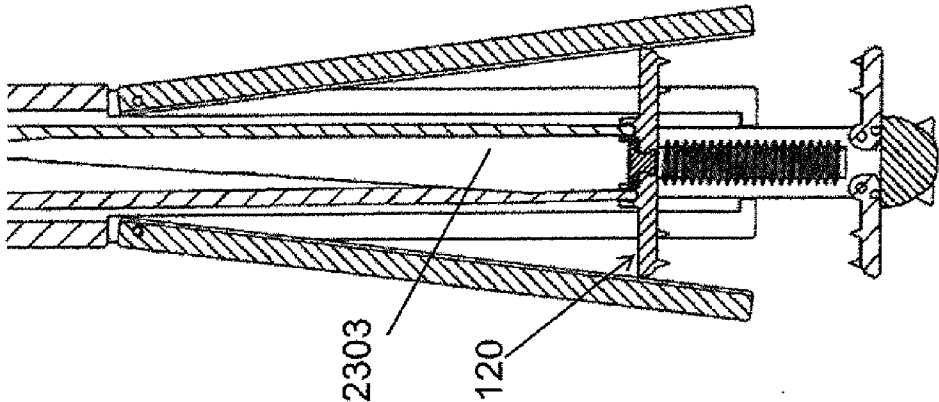

Fig. 44B

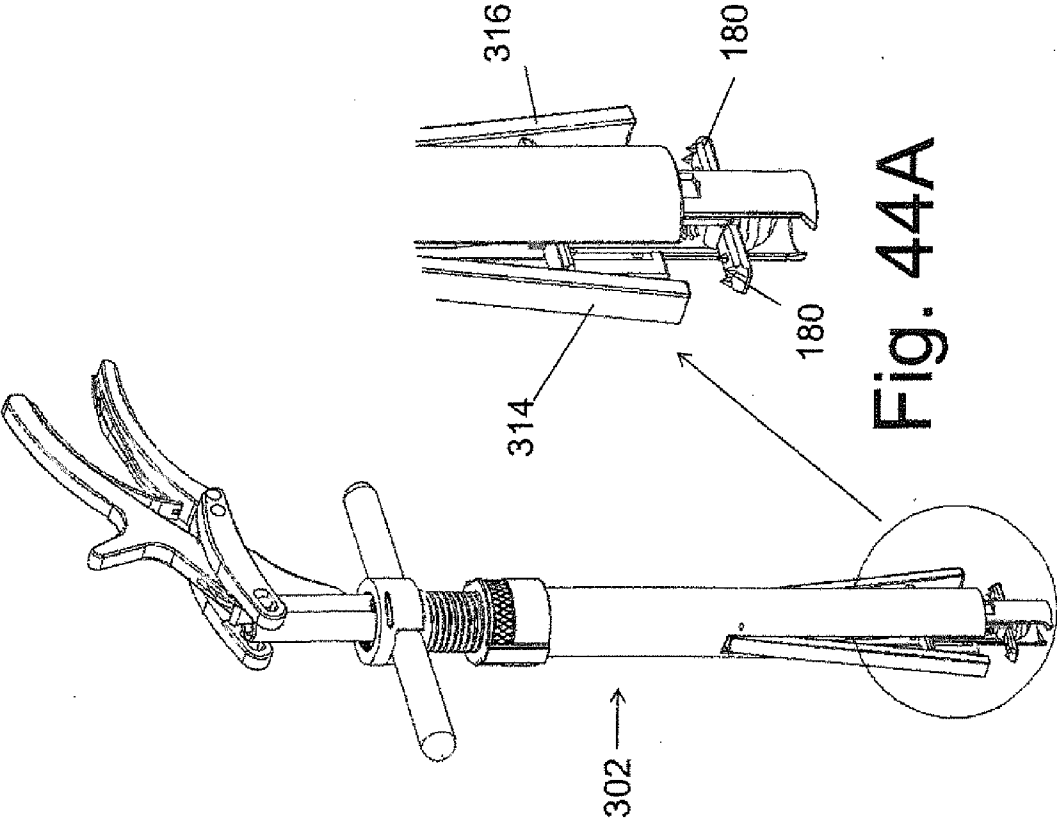
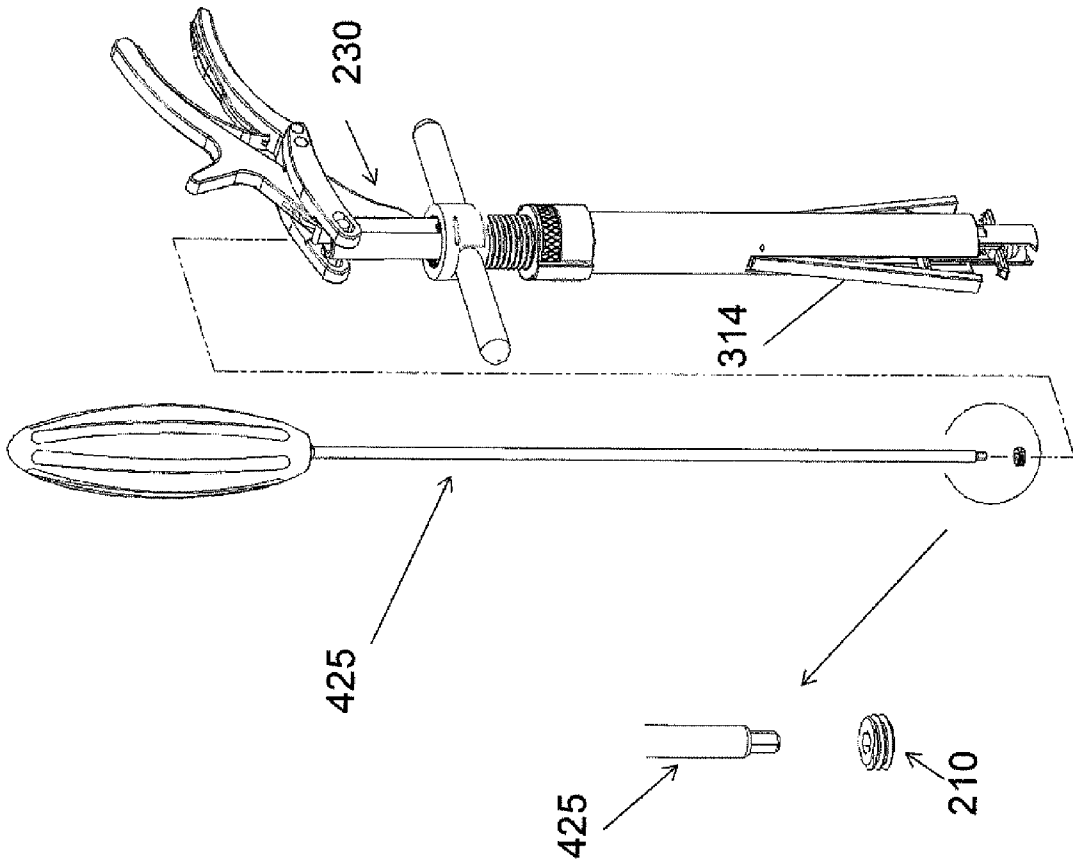

Fig. 44A

Fig. 45



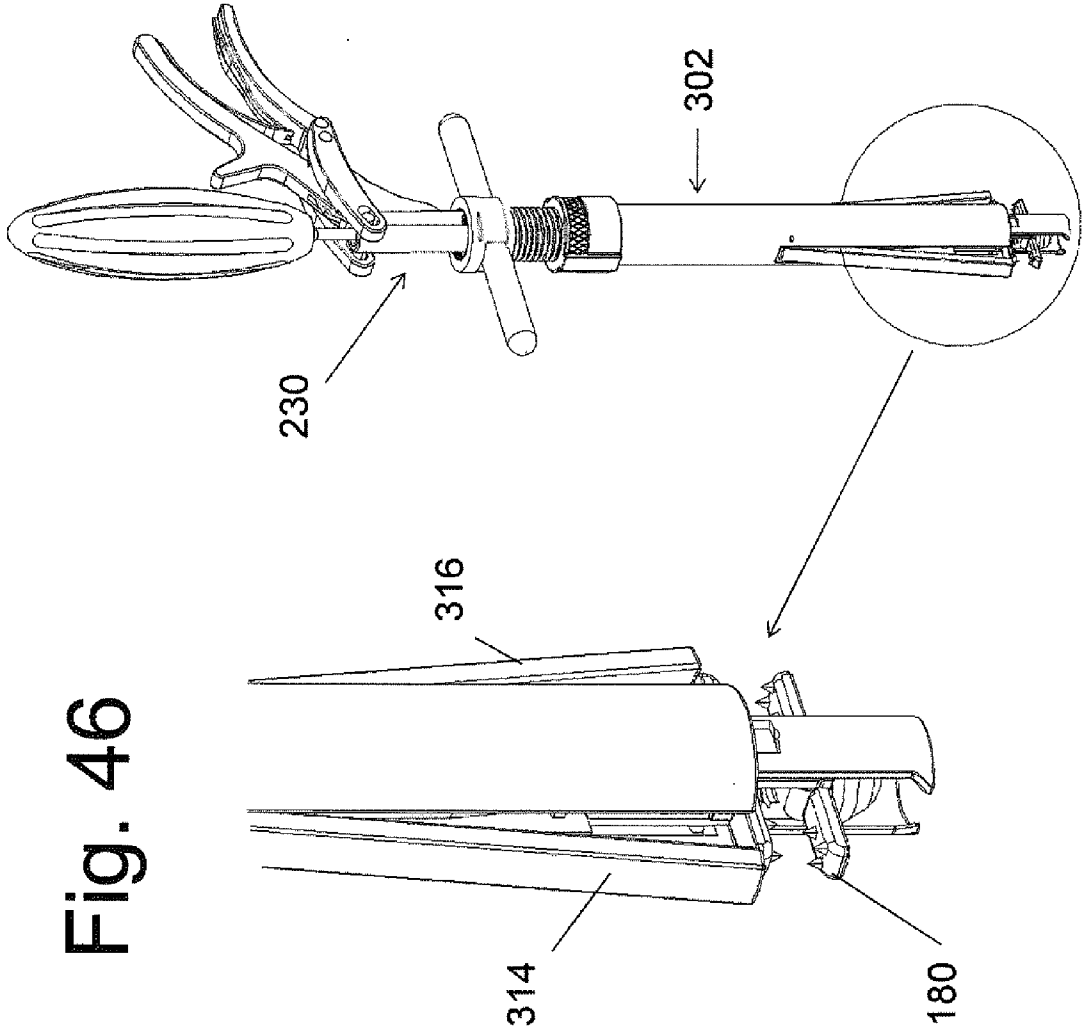

Fig. 46

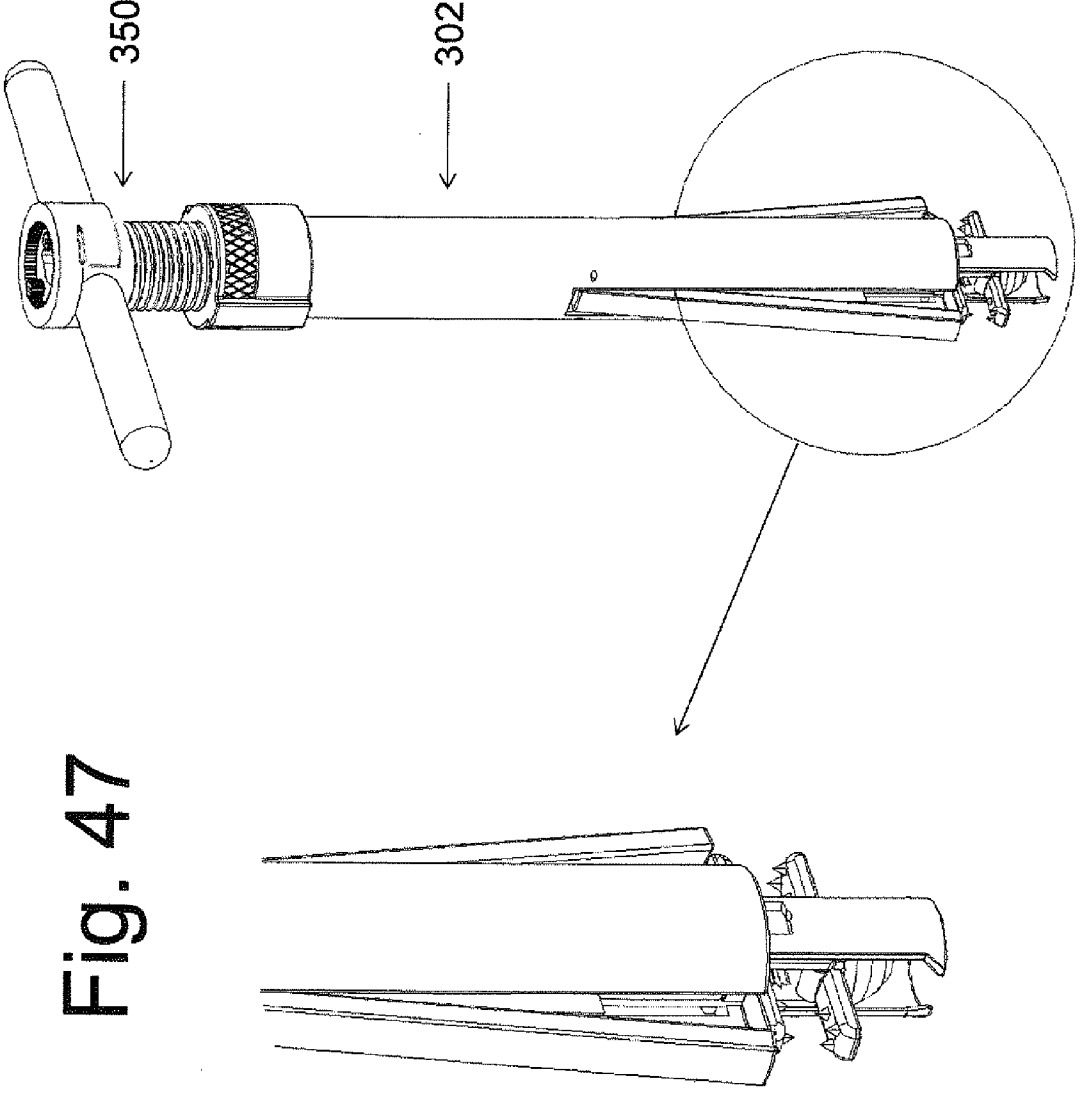

Fig. 47

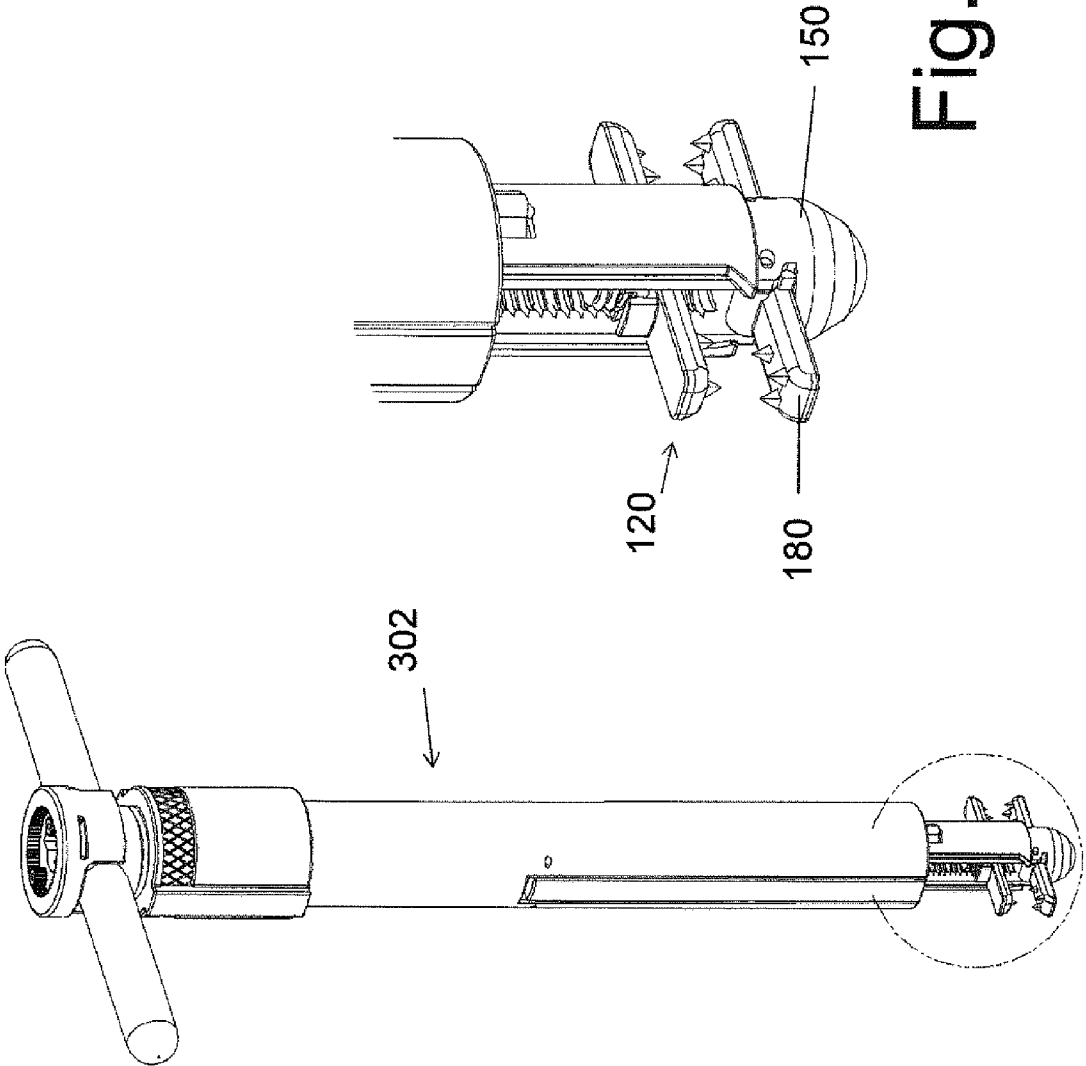

Fig. 48

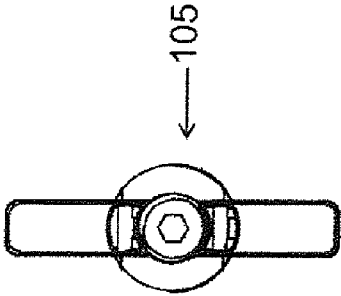
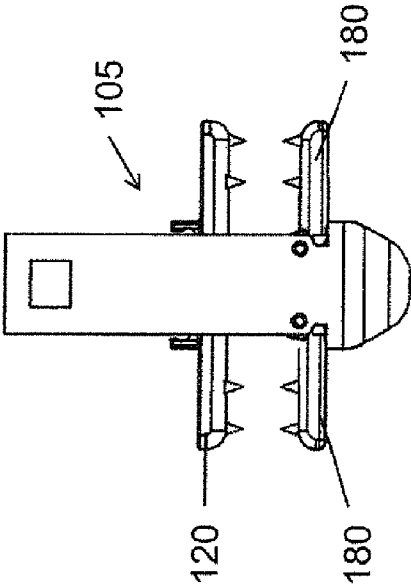
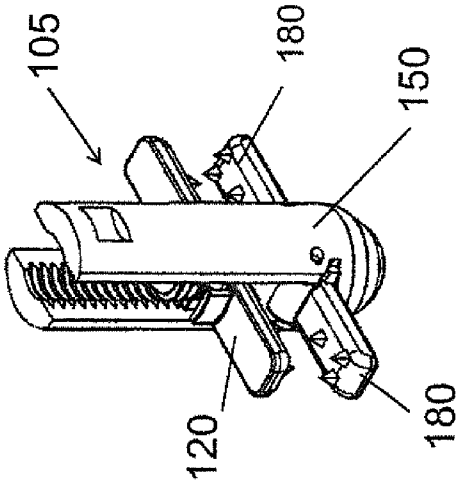
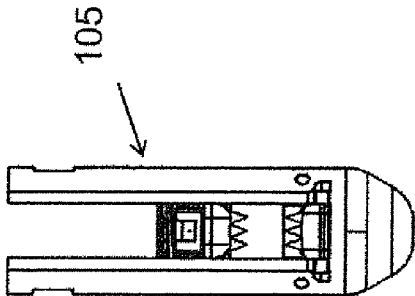

Fig. 49



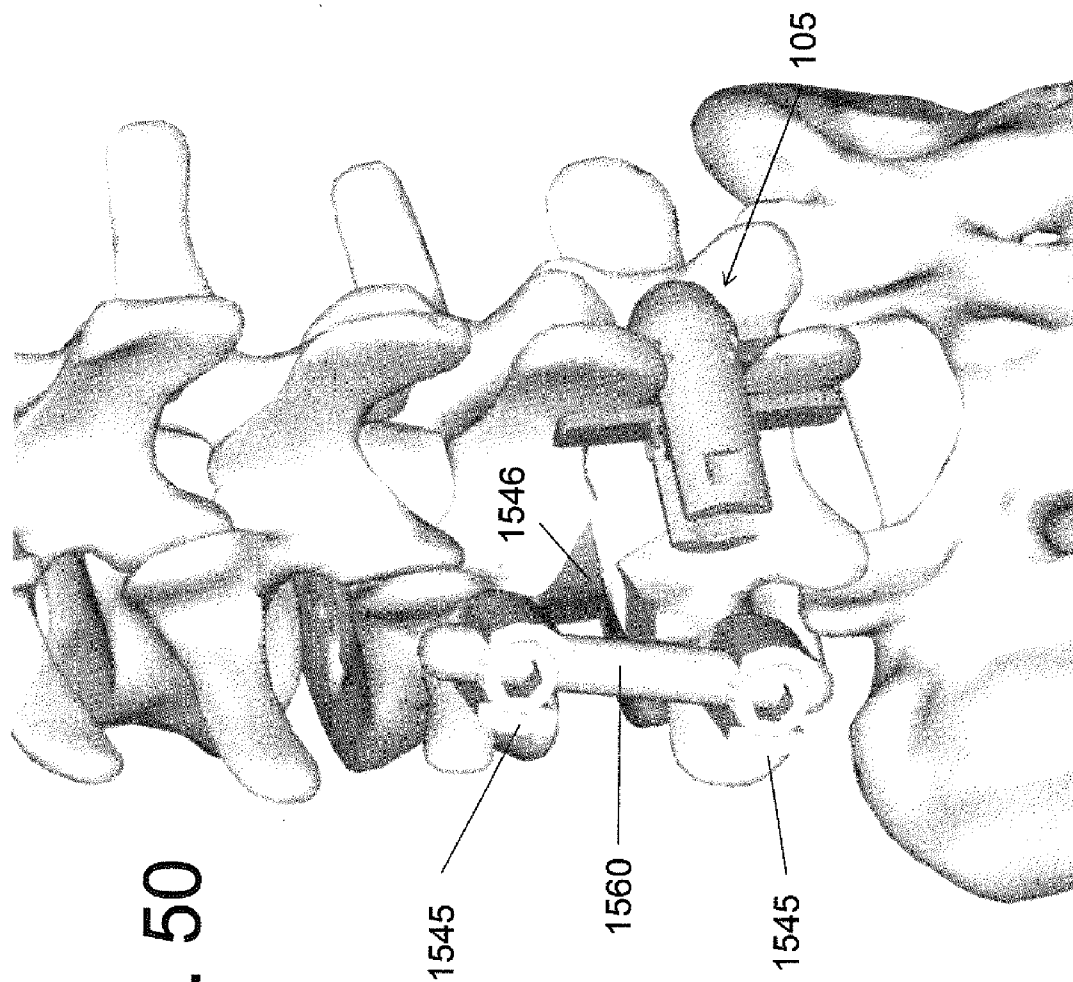

Fig. 50

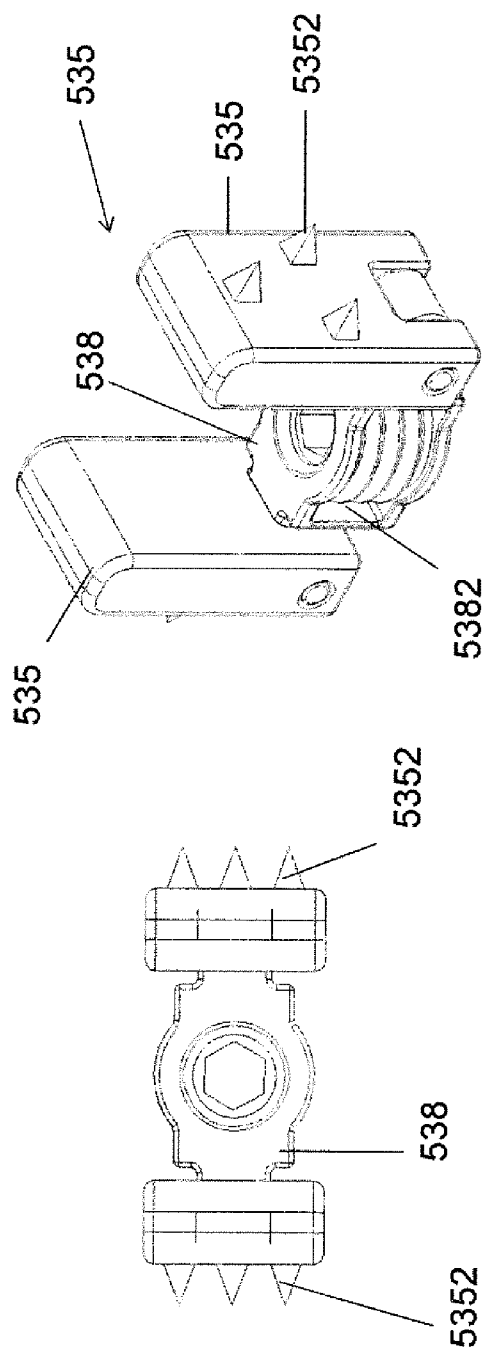

Fig. 51

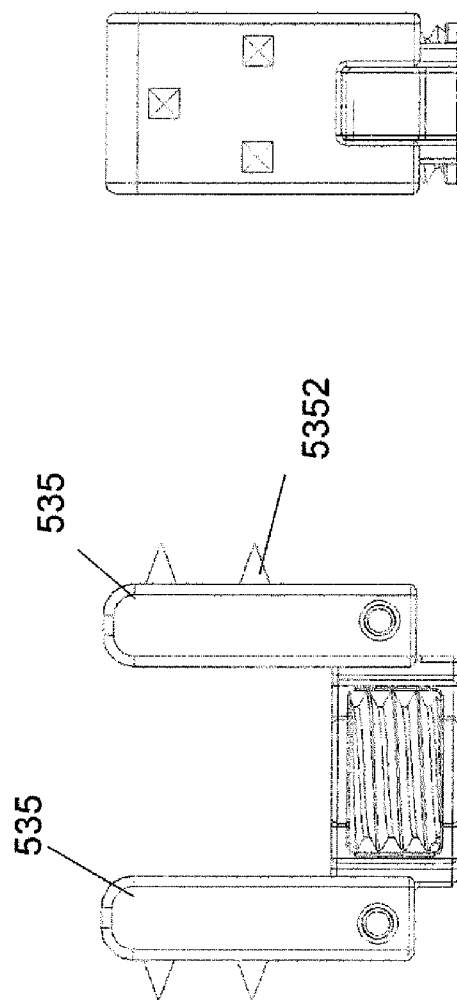

Fig. 52

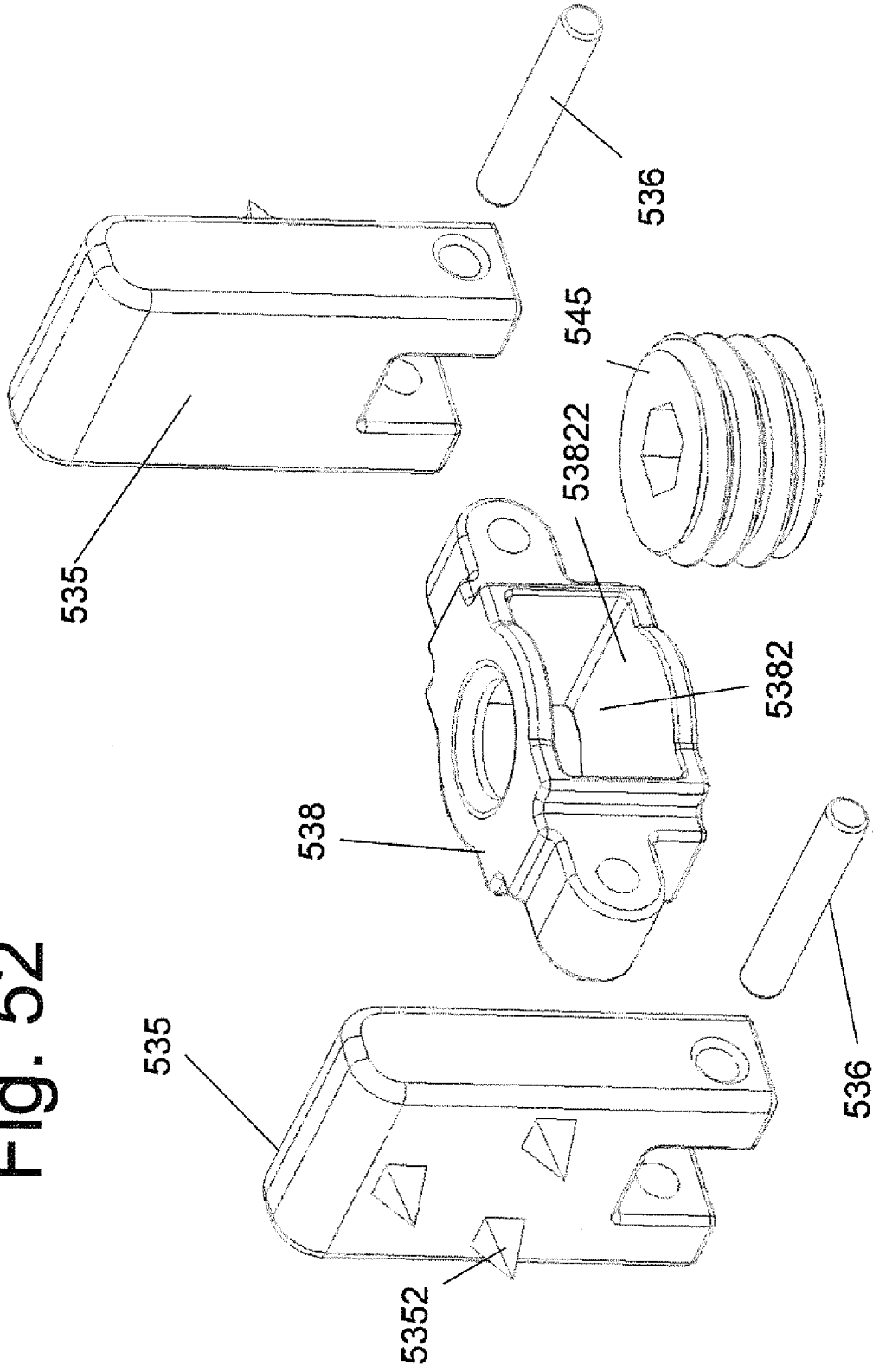
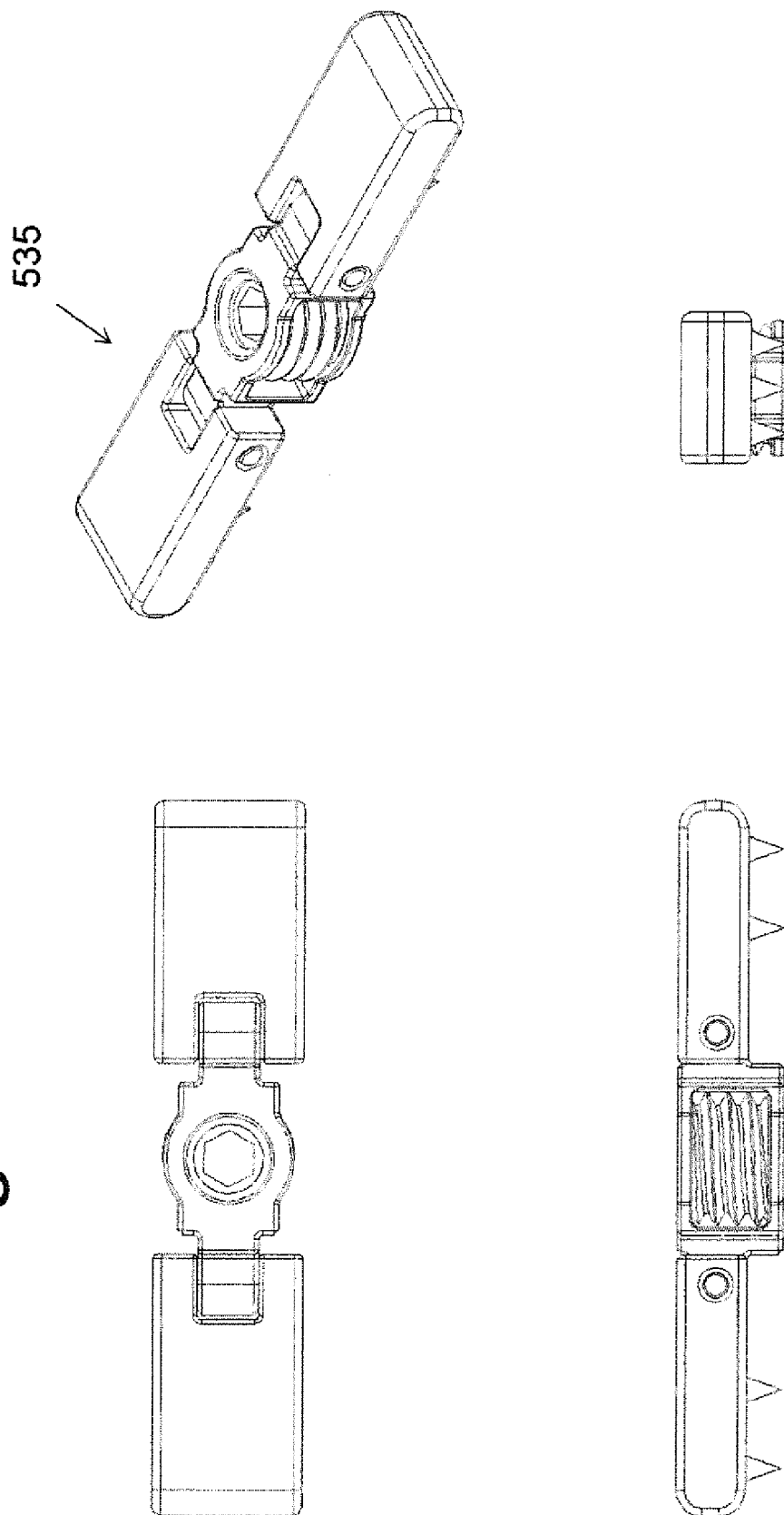

Fig. 53



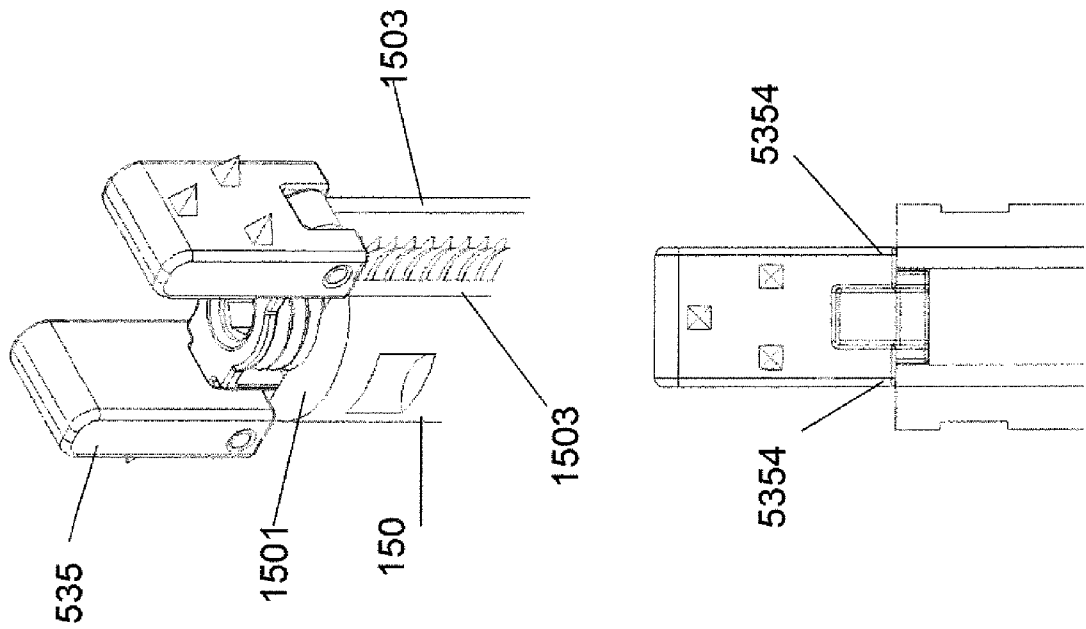

Fig. 54

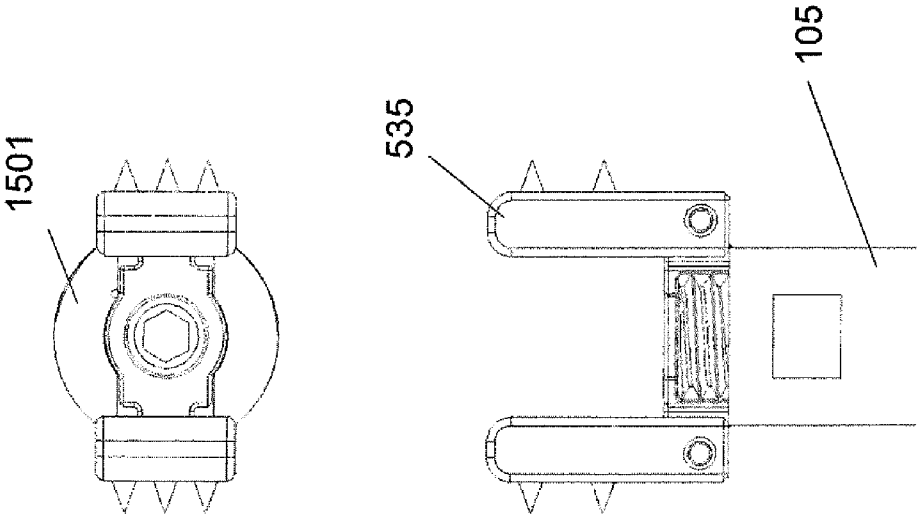

Fig. 55

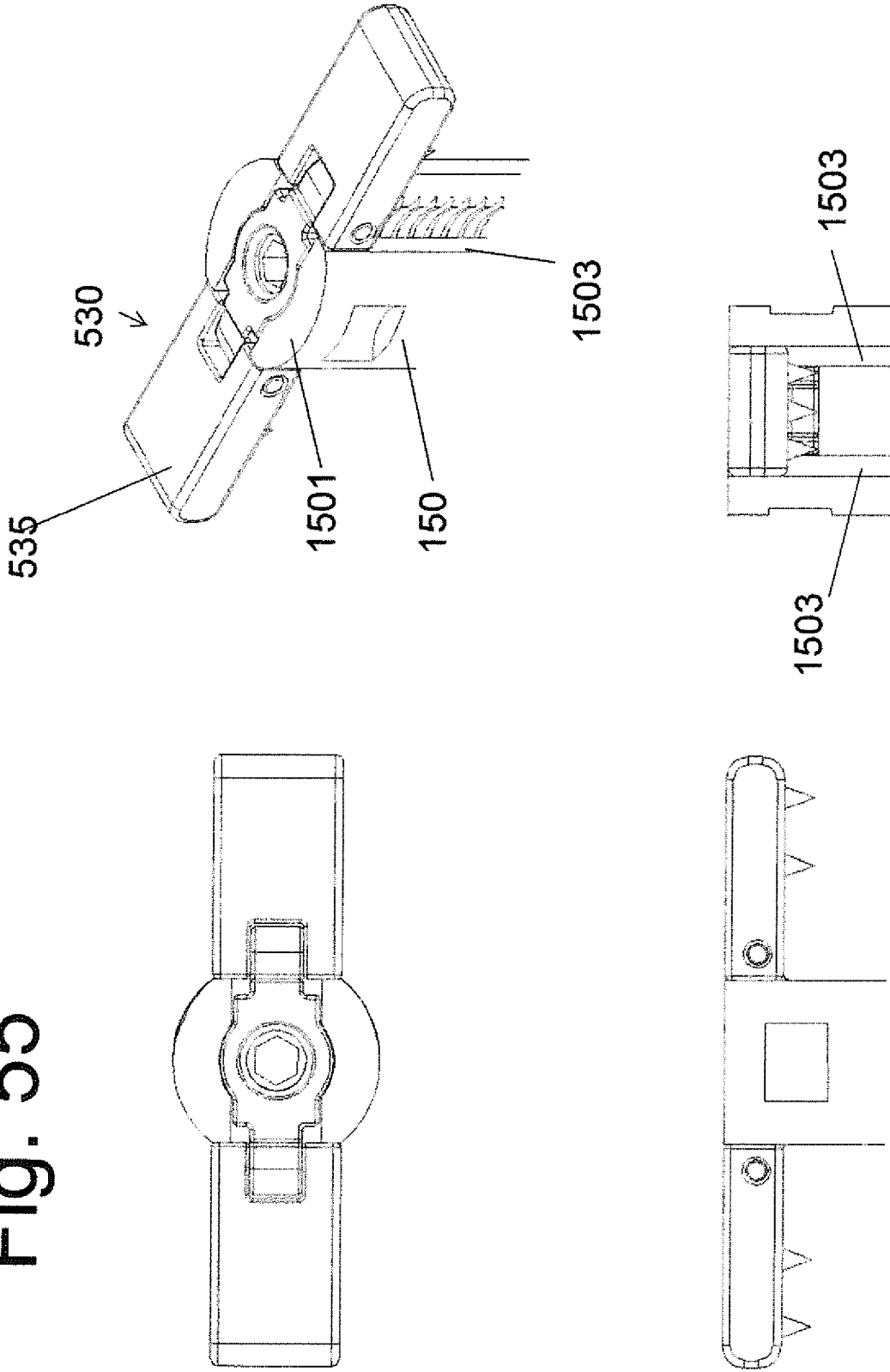
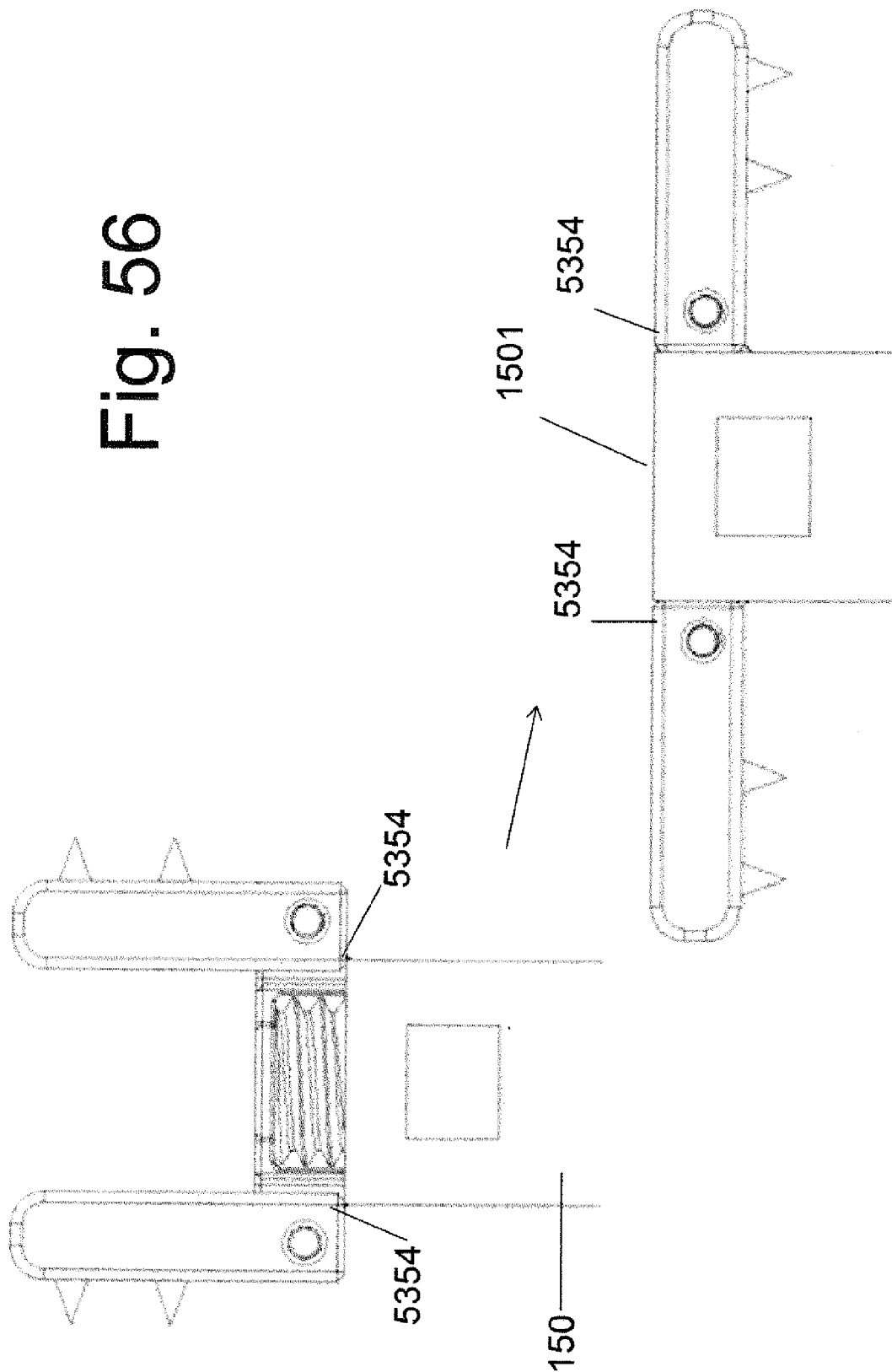

Fig. 56



**SPINOUS PROCESS FIXATION DEVICES
AND METHODS OF USE**

PRIORITY

[0001] This application claims priority to U.S. Provisional Patent Application Ser. No. 61/634,022 filed Feb. 22, 2012 of the same title, which is incorporated herein by reference in its entirety.

COPYRIGHT

[0002] A portion of the disclosure of this patent document contains material that is subject to copyright protection. The copyright owner has no objection to the facsimile reproduction by anyone of the patent document or the patent disclosure, as it appears in the Patent and Trademark Office patent files or records, but otherwise reserves all copyright rights whatsoever.

BACKGROUND

[0003] 1. Field of the Disclosure

[0004] This disclosure relates generally to bone fixation systems, components thereof, and methods of implant placement used to adjust, align and maintain the spatial relationship(s) of adjacent bones or bony fragments after surgical reconstruction of skeletal segments. In particular, this disclosure relates to devices that fixate the spinous processes at one vertebral level with the spinous process of another vertebra.

[0005] 2. Description of Related Technology

[0006] Whether from degenerative disease, traumatic disruption, infection or neoplastic invasion, alteration in the anatomical relationships between the spinal vertebrae can cause significant pain, deformity and disability. Spinal disease is a major health problem in the industrialized world and the surgical treatment of spinal pathology is an evolving discipline. The traditional surgical treatment of abnormal vertebral motion is the complete immobilization and bony fusion of the involved spinal segment and an extensive array of surgical techniques and implantable devices have been formulated to accomplish the treatment objective.

[0007] Regardless of the specific objectives of surgery, many surgeons employ implantable devices that maintain the desired spatial relationship(s) between adjacent vertebral bodies. The effectiveness of these devices is critically dependent on adequate fixation into the underlying bone. While screw fixation into the pedicle portion of the vertebral body has emerged as a common method of device fixation, it remains a substantial operation with multiple shortcomings.

SUMMARY

[0008] The present disclosure satisfies the need for the percutaneous delivery of an implant that can rigidly fixate the spinous process of a first superior bone and a second inferior bone of a functional spinal unit.

[0009] In one aspect, a device is disclosed. In one embodiment, the device is adapted to forcibly clamp onto the spinous processes of each of the vertebral bones. The device is sized to permit sufficient space for the implantation of bone forming material (for bone fusion) within the interspinous space adjacent to it.

[0010] Additionally, or alternatively, the implant may in another embodiment be adapted to contain a bone forming material within an internal cavity, wherein the bone forming

material forms a fusion between the first and the second vertebral bones through at least one opening of the internal cavity.

[0011] In another embodiment, the implant comprises: (i) an elongated body configured to extend along a longitudinal axis from a first proximal segment to a second distal segment, the elongated body comprising an internal bore configured to: accept a bone forming material therein, occupy at least a portion of an internal volume of the elongated body, and comprise at least one aperture configured to open onto an outer surface of the elongated body, (ii) at least one rotational bone abutment member configured to attach to the second distal segment of the elongated body and configured to rotate from a first orientation to a second orientation relative to the elongated body, (iii) at least one second bone abutment member configured to attach to the first proximal segment of the elongated body, and (iv) a locking mechanism positioned at the first proximal segment of the elongated body, the locking mechanism configured to be advanced in a first direction to produce movement of the at least one second bone abutment member towards the at least one rotational bone abutment member. Advancement of the locking mechanism in a second direction permits movement of the at least one second bone abutment member away from the at least one rotational bone abutment member.

[0012] In another aspect, a method for the percutaneous decompression of a spinal canal is disclosed. In one embodiment, the method comprises: (i) identifying on an imaging technique a spinal level to be implanted, (ii) making an incision lateral to a vertebral midline, (iii) advancing an orthopedic implant into an interspinous space of the spinal level to be decompressed, the orthopedic implant comprising an elongated body having an internal bore configured to accept a bone forming material therein, the internal bore occupying at least a portion of an internal volume of the elongated body and having an aperture opening onto an outer surface of the elongated body, (iv) attaching at least one rotational bone abutment member to a distal segment of the elongated body of the orthopedic implant, the at least one rotational bone abutment member configured to rotate from a first orientation to a second orientation relative to the elongated body, (v) attaching at least one second bone abutment member to a proximal segment of the elongated member, (vi) positioning a locking mechanism at the proximal segment of the elongated body, and (vii) advancing the locking mechanism along a first direction to produce movement of the at least one second bone abutment member towards the at least one rotational bone abutment member and capturing a spinous process of each vertebral bone abutting the implanted inter-spinous space between the at least one rotational bone abutment member and the at least one second bone abutment member. The advancement of the locking mechanism in a second direction opposing the first direction permits movement of the at least one second bone abutment member away from the at least one rotational bone abutment member.

[0013] In another aspect a method for treatment of a spinal segment is disclosed. In one embodiment, the spinal segment comprises first and second adjacent spinous processes, and the method comprises: (i) positioning a bone forming material within an internal bore of an orthopedic implant, the internal bore comprising at least 20% of an internal volume of the orthopedic implant and the bone forming material being configured to fuse with at least one of the first and second spinous processes, (ii) advancing a first segment of the ortho-

pedic implant from a first ipsilateral side to a second contralateral side of an interspinous ligament that interconnects the first and second spinous processes, the first segment comprising a segment of an elongated body and at least a first bone abutment member coupled to the elongated body, (iii) rotating the first bone abutment member relative to the elongated body, the rotated first bone abutment member being at least partially positioned within the second contralateral side of the interspinous ligament, (iv) causing a surface of a second bone abutment member to abut a side surface of at least one of the first and second spinous processes, the second bone abutment member being at least partially positioned within the first ipsilateral side of the interspinous ligament, (v) translating the second bone abutment surface towards the first bone abutment surface by advancement of a locking mechanism of the orthopedic implant, and (vi) causing a forceful immobilization of at least one of the first and second spinous processes between the first and the second one abutment members.

[0014] In another aspect, a kit for positioning an orthopedic implant within a subject is disclosed. In one embodiment, the kit comprises: (i) an orthopedic implant comprising an elongated body extending along a longitudinal axis from a first proximal segment to a second distal segment, the elongated body comprising an external surface and an internal bore configured to occupy at least twenty percent of an internal volume of the elongated body, the internal bore further comprising an aperture configured to open onto the external surface, (ii) at least one rotatable bone abutment member attached to the second distal segment of the elongated member and configured to rotate from a first orientation to a second orientation relative to the elongated body, the at least one rotatable bone abutment member comprising an external surface positioned along the external surface of the orthopedic implant, and (iii) at least one elongated implant placement device configured to reversibly couple to the first proximal segment of the orthopedic implant, the at least one elongated implant placement device further configured to forcibly rotate the at least one rotatable bone abutment member from the first to the second orientation relative to the elongated body through an application of a force transmitted directly from the at least one elongated implant placement device to the external surface of the at least one rotatable bone abutment member.

[0015] The details of one or more embodiments are set forth in the accompanying drawings and description below. Other features, objects, and advantages will be apparent from the following description, the accompanying drawings and from the claims.

BRIEF DESCRIPTION OF THE DRAWINGS

[0016] FIG. 1 is a perspective view of an embodiment of a fixation device in an assembled state according to the disclosure.

[0017] FIG. 2 is an exploded perspective view of the embodiment of the fixation device of FIG. 1.

[0018] FIG. 3 illustrates diagrammatic representations of a spinal vertebral bone.

[0019] FIG. 4A is a posterior view of an Functional Spinal Unit (FSU) illustrating a posterior surface of the adjacent vertebrae of and the articulations between them.

[0020] FIG. 4B is an oblique view of the FSU of FIG. 4A, illustrating a posterior surface of the adjacent vertebrae of and the articulations between them.

[0021] FIG. 5 is a cross sectional view of the torso at the level of the lumbar spine for use with the common flank approach.

[0022] FIG. 6 is a schematic representation of the posterior aspect of a patient illustrating an XLIF incision location.

[0023] FIG. 7A is a schematic representation of the posterior aspect of a patient illustrating a TLIF incision location.

[0024] FIG. 7B is a cross sectional view of the torso at the level of the lumbar spine for use with the single incision approach.

[0025] FIG. 8 illustrates perspective and cross-sectional views of the housing member of the fixation device of FIG. 1.

[0026] FIG. 9 illustrates additional cross-sectional views of the housing member of the fixation device of FIG. 1.

[0027] FIG. 10 illustrates side and perspective views of the rotational member of the fixation device of FIG. 1.

[0028] FIG. 11 illustrates side and perspective views of the locking nut of the fixation device of FIG. 1.

[0029] FIG. 12 illustrates side, top, and perspective views of the plate member of the fixation device of FIG. 1.

[0030] FIG. 13 illustrates side, top, bottom, and perspective views of the retaining member of the fixation device of FIG. 1.

[0031] FIG. 14 is a perspective view of an assembly of the exemplary plate member of FIG. 12 and the retaining member of FIG. 13.

[0032] FIG. 15A is a side view of the assembly of FIG. 14.

[0033] FIG. 15B is a cross-sectional view of the assembly of FIG. 14.

[0034] FIGS. 16A and 16B illustrate side and perspective views of the device of FIG. 1 with the plate assembly of FIG. 14 in the "closed" configuration.

[0035] FIG. 17 illustrates a perspective view of the device of FIG. 1 with the plate assembly of FIG. 14 in the "open" configuration.

[0036] FIG. 18 is a perspective view of an exemplary instrument for reversibly rotating the plate assembly of FIG. 14 from the "open" to the "closed" configuration within the exemplary implant of FIG. 1.

[0037] FIG. 19 is an orthogonal view of the exemplary instrument of FIG. 18.

[0038] FIG. 20 is an exploded view of the exemplary instrument of FIG. 18.

[0039] FIG. 21 is a close-up view of the end segments of the exemplary instrument of FIG. 18.

[0040] FIGS. 22A and 22B illustrate side views of the interaction of the exemplary instrument of FIG. 18 with an exemplary plate member of the assembly of FIG. 14.

[0041] FIG. 23 is a perspective view of the actuated exemplary instrument of FIG. 18 with the rotated exemplary assembly of FIG. 14.

[0042] FIG. 24 is a cross-sectional view of the actuated exemplary instrument of FIG. 18 with the rotated exemplary assembly of FIG. 14.

[0043] FIG. 25 illustrates perspective views of the "open" and "closed" grip positions of the exemplary instrument of FIG. 18 producing translation of the two ends of the instrument.

[0044] FIG. 26A is an exploded view of an outer member of an exemplary instrument used to position the exemplary implant of FIG. 1 at the target interspinous space.

[0045] FIG. 26B illustrates the outer member of the exemplary instrument used to position the exemplary implant of FIG. 1 at the target interspinous space with side doors in a closed position.

[0046] FIG. 26C illustrates the outer member of the exemplary instrument used to position the exemplary implant of FIG. 1 at the target interspinous space with side doors in an open position.

[0047] FIG. 27A is a cross-sectional view of the outer member of the exemplary instrument used to position the exemplary implant of FIG. 1 at the target interspinous space.

[0048] FIG. 27B illustrate close-up views of the distal protrusions of the outer member of the exemplary instrument used to position the exemplary implant of FIG. 1 at the target interspinous space.

[0049] FIG. 28A is a close-up view of the proximal aspect of an inner member of the exemplary instrument used to position the exemplary implant of FIG. 1 at the target interspinous space.

[0050] FIG. 28B illustrate an oblique and a cross-sectional view of the inner member of the exemplary instrument used to position the exemplary implant of FIG. 1 at the target interspinous space.

[0051] FIG. 29A is an orthogonal view of the inner member of the exemplary instrument used to position the exemplary implant of FIG. 1 at the target interspinous space.

[0052] FIG. 29B is a cross-sectional view through the inner member of the exemplary instrument used to position the exemplary implant of FIG. 1 at the target interspinous space.

[0053] FIG. 30 is an exploded view of the inner member of the exemplary instrument used to position the exemplary implant of FIG. 1 at the target interspinous space illustrating the locking members positioned within the bores.

[0054] FIG. 31 is a close-up view of the projection of a top surface of the inner member of the exemplary instrument used to position the exemplary implant of FIG. 1 at the target interspinous space after advancement of a portion of a locking member thereof within a bore.

[0055] FIG. 32 is a perspective view of the assembled exemplary instrument used to position the exemplary implant of FIG. 1 at the target interspinous space

[0056] FIG. 33 illustrates a coupling of the inner and outer members of the exemplary instrument used to position the exemplary implant of FIG. 1 at the target interspinous space.

[0057] FIG. 34 illustrates an assembled exemplary instrument used to position the exemplary implant of FIG. 1 at the target interspinous space in a locked position.

[0058] FIG. 35 illustrates an assembled exemplary instrument used to position the exemplary implant of FIG. 1 at the target interspinous space in an unlocked position.

[0059] FIG. 36A is a close-up view of the distal end of the assembled exemplary instrument of FIG. 34 in the locked position.

[0060] FIG. 36B is a close-up view of the distal end of the assembled exemplary instrument of FIG. 35 in the unlocked position.

[0061] FIG. 37 illustrates cross-sectional views of the assembled exemplary instrument used to position the exemplary implant of FIG. 1 at the target interspinous space.

[0062] FIG. 38 illustrates a perspective and close-up view of the positioning of the exemplary implant of FIG. 1 for coupling to the exemplary instrument for positioning the implant at the target interspinous space.

[0063] FIG. 39 illustrates a perspective and close-up view of the coupling of the exemplary implant of FIG. 1 within the exemplary instrument for positioning the implant at the target interspinous space.

[0064] FIG. 40 is a perspective view of rotation of the rotational members of the exemplary implant of FIG. 1 while within the exemplary instrument for positioning the implant at the target interspinous space.

[0065] FIG. 41 is a perspective view of positioning of the rotational members of the exemplary implant of FIG. 1 to capture the two spinous processes that border the target interspinous space while the implant is within the exemplary instrument for positioning the implant at the target interspinous space.

[0066] FIG. 42 illustrates a coupling of the exemplary instrument of FIG. 18 with the plate assembly of FIG. 14 attached thereto to the exemplary instrument of FIG. 32 for positioning the implant at the target interspinous space.

[0067] FIG. 43A illustrates another view of the coupling of the exemplary instrument of FIG. 18 with the plate assembly of FIG. 14 attached thereto to the exemplary instrument of FIG. 32 for positioning the implant at the target interspinous space.

[0068] FIG. 43B is a cross-sectional view of the coupling of the exemplary instrument of FIG. 18 with the plate assembly of FIG. 14 attached thereto to the exemplary instrument of FIG. 32 for positioning the implant at the target interspinous space.

[0069] FIG. 44A is a perspective and close-up view of the actuation of the exemplary instrument of FIG. 18 to rotate the plate assembly of FIG. 14 attached thereto to be substantially parallel to the rotational members of the exemplary implant of FIG. 1.

[0070] FIG. 44B is a cross-sectional view of the actuation of the exemplary instrument of FIG. 18 to rotate the plate assembly of FIG. 14 attached thereto to be substantially parallel to the rotational members of the exemplary implant of FIG. 1.

[0071] FIG. 45 illustrates a coupling of an exemplary screw driver for attaching a locking nut to the implant assembly within the exemplary instrument of FIG. 18 and the exemplary instrument of FIG. 32 for positioning the implant at the target interspinous space.

[0072] FIG. 46 illustrates a perspective and close-up view of the coupling of the exemplary screw driver of FIG. 45 within the exemplary instrument of FIG. 18 and the exemplary instrument of FIG. 32.

[0073] FIG. 47 illustrates a perspective and close-up view of the assembled implant within the exemplary instrument of FIG. 32 having the screw driver of FIG. 45 and the exemplary instrument of FIG. 18 removed.

[0074] FIG. 48 illustrates a perspective and close-up view of the rotation of the exemplary instrument of FIG. 32 for removal thereof after implantation of the exemplary assembled implant of FIG. 1 at the target interspinous space.

[0075] FIG. 49 illustrates top, side, and perspective views of the exemplary assembled implant of FIG. 1.

[0076] FIG. 50 is a perspective view of an exemplary implant using TLIF methods.

[0077] FIG. 51 illustrates side, top, and perspective views of an alternative plate member for use with the fixation device of FIG. 1 in a "closed" position.

[0078] FIG. 52 illustrates an exploded view of the alternative plate member of FIG. 51.

[0079] FIG. 53 illustrates side, top, and perspective views of the alternative plate member of FIG. 51 in an “open” position.

[0080] FIG. 54 illustrates side, top, and perspective views of the alternative plate member of FIG. 51 in the “closed” position and attached to the fixation device of FIG. 1.

[0081] FIG. 55 illustrates side, top, and perspective views of rotation of the alternative plate member of FIG. 51 to the “open” position.

[0082] FIG. 56 illustrates side views of the transition of the alternative plate member of FIG. 51 from the “closed” to the “open” position.

[0083] All Figures © Copyright 2013. Samy Abdou All rights reserved.

DETAILED DESCRIPTION

[0084] Described herein are, inter alia, devices and methods for the treatment of abnormal spinal stability and stenosis of the spinal canal by the implantation of orthopedic devices between skeletal segments. In an embodiment, a device is disclosed that rigidly fixates the spinous processes of two adjacent vertebral bones relative to one another. In one embodiment of device use, the implant is percutaneously placed into the interspinous space and may be used to provide decompression of spinal stenosis by retaining the spinous process in the distracted position. The implant also affixes the spinous processes of the vertebral bones on either side of the implanted interspinous space in order to retain and immobilize the vertebral bones relative to one another.

[0085] The device is inserted from a skin incision that is on a first side of the target interspinous. Rotatable members of the implant are advanced across the interspinous space from the first side (ipsilateral to site of skin incision) to a second contralateral side. The long axis of the implant is positioned substantially parallel to the trajectory used for implantation. After at least a distal segment of the rotatable members is positioned on the contralateral side of the interspinous space, at least one rotatable member is made to rotate, wherein, after rotation, the rotatable members had been substantially rotated by ninety degrees so that its long axis is now substantially along the long axis of the spinal column and perpendicular to the trajectory used for device implantation. In the rotated position, at least a distal segment of the rotated rotatable member is positioned to overly a segment of the lateral side surface of one of said first or the second spinous processes.

[0086] A second member is positioned on the side of the spinous process that is ipsilateral to the site of skin incision. A locking member is used to retain the second member attached to the device. As the locking member is advanced further, the spinous processes are forcibly captured between the rotatable members on the contralateral side of the spinous processes and the separate member positioned on the ipsilateral side of the spinous processes.

[0087] In another embodiment, the mechanisms for rotation of the rotatable arms as well as the locking mechanism are engaged and actuated through deployment instruments that are substantially positioned parallel to the trajectory of device implantation. Further, the engageable segments of these mechanisms are located on the ipsilateral side of the spinous processes at the time of engagement by the deployment instrument (whereas the rotatable members are located on the contralateral side of the spinous processes).

[0088] In an embodiment of implant use, the implant is percutaneously advanced into the posterior column of a spinal

segment under radiographic guidance. The implant may be used at any spinal level but is particularly suited for implantation into the lumbar spine. While the disclosed implant may be used by itself to fuse the superior vertebral bone and the inferior vertebral bone that abut the implanted interspinous space, in other embodiments, the disclosed implant may be used with other orthopedic implants. The implant is particularly suited for use in the lumbar spine wherein another orthopedic implant is placed (at the same or at another operation) into the anterior column of the same spinal segment using a lateral approach to the anterior column. (The lateral-approach lateral fusion operations are collectively known as XLIF, DLIF and the like. An example of this method is disclosed in “Extreme Lateral Interbody Fusion (XLIF): a novel surgical technique for anterior lumbar interbody fusion” by Ozgur, Aryan et al. in *Spine J.* 2006 July-August; 6(4):435-43, which is hereby incorporated by reference in its entirety.)

[0089] In this way, both the anterior column implant (i.e., the one XLIF, DLIF and the like implant as well the other implant of the current application) may be placed through a single lateral skin incision or two closely adjacent skin incisions to provide a truly percutaneous or minimally invasive approach. Further, this method provides circumferential (i.e., anterior and posterior) expansion and decompression of the spinal canal so as to treat spinal stenosis through anterior and posterior decompression of the spinal canal. That is, placement of an anterior column implant (via XLIF, DLIF and the like) provides anterior decompression of the spinal column, whereas placement of the disclosed implant into the posterior column (between the spinous processes) provides posterior decompression of the spinal column—and both can be performed through a common flank approach (see FIG. 5).

[0090] In another embodiment of use, the device may be deployed through a single incision that is posterior and lateral to the transverse processes of the spinal level to be implanted (see FIG. 7). (A surgical procedure that employs a similar incision is known to those of ordinary skill in the art as TLIF.) Bone screws are advanced into the pedicle portion of bone on the side of the vertebrae that is ipsilateral to the incision. The screws are rigidly interconnected with a rod. The device disclosed herein is then placed through the same skin incision into the interspinous space. While contralateral pedicle screws may be also placed by the operating surgeon, the implanted interspinous device obviates the need for contralateral screw placement.

[0091] FIG. 1 is a perspective view of an embodiment of a fixation device 105 in an assembled state. FIG. 2 shows a perspective view of the device 105 in an exploded view. The fixation device 105 is comprised of a plate member 120, rotation arms 180, and housing member 150 each of which will be described in more detail below. The fixation device 105 also includes a locking nut 210, retaining member 195 and spring members 190 (i.e., Belleville washers and the like).

[0092] The device 105 can be used to interconnect and fixate the spinous process of a first vertebral bone with the spinous process of a second adjacent vertebral bone. The device permits a surgeon to percutaneously implant it into the posterior column of the spine from a lateral, or flank incision, as will be discussed in more detail below. As previously discussed, the device is particularly useful in the fixation of the posterior spinal column of a target functional

spinal unit of a spinal column—in conjunction with a lateral approach fusion of the disc space of the same target functional spinal unit.

[0093] As used herein, the anterior column generally designates a portion of the vertebral body and/or Functional Spinal Unit (FSU) that is situated anterior to the posterior longitudinal ligament. Thus, its use in this application encompasses both the anterior and middle column of Denis (see e.g., “The three column spine and its significance in the classification of acute thoracolumbar spinal injuries” by Denis, F. Spine 1983 November-December; 8(8):817-31, which is incorporated by reference in its entirety). The illustrations and definitions of anatomical structures are known to those of ordinary skill in the art. They are described in more detail in Atlas of Human Anatomy, by Frank Netter, third edition, Icon Learning Systems, Teterboro, N.J. The text is hereby incorporated by reference in its entirety. It should be appreciated that the directional language and terms regarding orientation such as upper, lower, upward, downward etc. are used merely for convenience of description and are not intended to be limiting.

[0094] FIG. 3 illustrates diagrammatic representations of a spinal vertebral bone **802** in multiple views. For clarity of illustration, the vertebral bone of FIG. 3 and those of other illustrations disclosed herein are represented schematically and it should be appreciated that actual vertebral bodies may include anatomical details that are not shown in these figures. Further, it is understood that the vertebral bones at a given level of the spinal column of a human or animal subject will contain anatomical features that may not be present at other levels of the same spinal column. The illustrated vertebral bones are intended to generically represent vertebral bones at any spinal level without limitation. The disclosed devices and methods may be applied at any spinal level.

[0095] Vertebral bone **802** contains an anteriorly-placed vertebral body **804**, a centrally placed spinal canal **806** and posteriorly-placed lamina **808**. The pedicle segments **810** of vertebral bone **802** form the lateral aspect of the spinal canal **806** and connect the laminae **808** to the vertebral body **804**. The spinal canal **806** contains neural structures such as the spinal cord and/or nerves. A midline protrusion termed the spinous process SP extends posteriorly from the medial aspect of laminae **808**. A protrusion extends laterally from each side of the posterior aspect of the vertebral bone **802** and is termed the transverse process TP. A right transverse process RTP extends to the right and a left transverse process LTP extends to the left. A superior protrusion extends superiorly above the lamina **808** on each side of the vertebral midline and is termed the superior articulating process SAP. An inferior protrusion extends inferiorly below the lamina **808** on each side of the vertebral midline and is termed the inferior articulating process IAP. Note that the posterior aspect of the pedicle **810** can be accessed at an indentation **811** in the vertebral bone **802** between the lateral aspect of the SAP and the medial aspect of the transverse process TP. In surgery, it can be common practice to anchor a bone fastener into the pedicle portion **810** of a vertebral bone **802** by inserting the fastener through indentation **811** and into the underlying pedicle **810**.

[0096] FIGS. 4A and 4B illustrate a FSU, which includes two adjacent vertebrae and the intervertebral disc between them. The intervertebral disc resides between the inferior surface of the upper vertebral body and the superior surface of the lower vertebral body, although it is not specifically shown

in the figures. FIG. 4A shows the posterior surface of the adjacent vertebrae and the articulations between them. FIG. 4B shows an oblique view. The FSU contains a three joint complex between the two vertebral bones, with the intervertebral disc comprising the anterior joint. The posterior joints include a facet joint **814** on each side of the midline, wherein the facet joint **814** contains the articulation between the IAP of the superior vertebral bone and the SAP of the inferior bone.

[0097] The interspinous space is generally defined as the space immediately between the spinous processes of a superior vertebral bone and the spinous process of an immediately adjacent inferior vertebral bone. The interspinous space is limited anteriorly by the spinal canal **806** and posteriorly by the posterior tip of the spinous processes. For the purpose of this application, the right lateral aspect of the interspinous space is limited by the right lateral side of the spinous processes whereas the left lateral aspect of the interspinous space is limited by the left lateral side of the spinous processes. Note that the spinous processes of adjacent vertebral bones may be rotated in the axial plane relative to one another because of biological and/or individual variation (schematically shown in FIG. 4A). The interspinous space would continue to be defined as residing between the spinous processes of the superior and inferior vertebral bones.

[0098] With respect to FIGS. 8 & 9, the housing member **150** extends from a proximal end to a distal end **1502** along the direction of a longitudinal axis. The housing member is a generally cylindrical device having a tapered, closed end **1502** and an opposing end **1501**. Housing member **150** comprises an external surface **1500**. The opposing end **1501** contains an internal bore **1504** that extends substantially along the central axis. The wall of bore **1504** contains threads **1506**. Bore holes **152** accept pins **202** that retain rotational members **180**. Recess **204** accepts a protrusion **374** of locking member **370** of a placement instrument that is used to guide the implant to the implantation side.

[0099] As shown in FIG. 8, the internal bore **1504** is open onto the external surface **1500** and the space external to member **150** through at least one side aperture **15042** that emerges between the surfaces **1503**. In one embodiment, the bore **1504** is open onto the external surface **1500** through at least two opposing side surfaces (as shown in FIG. 9). In this way, the bore **1504** may accept a bone forming material that is configured to form a bony fusion with a bony surface external to member **150**. In one variant, the bony surface is positioned to abut at least a segment of an external surface of member **150**. It is appreciated that the bore **1504** may occupy any percentage of the internal volume of member **150**. For example, the bore **1504** may occupy at least 80% of the internal volume of member **150**. In another particular embodiment, the bore **1504** occupies at least 60% of the internal volume of member **150**. In yet another example, the bore **1504** occupies at least 40% of the internal volume of member **150**. In another example, the bore **1504** occupies at least 20% of the internal volume of member **150**. Side aperture(s) **15042** must be of sufficient size to permit a bony fusion between the bone forming material of bore **1504** and the bony structure positioned outside of member **150**. That is, the aperture(s) **15042** are sized to allow enough bone formation to immobilize member **150** relative to the adjacent bony structure. In one embodiment, the aperture has, at its intersection with the external surface **1500**, a surface area having bone forming material that is at least 5% of that of the surface area of

external surface **1500**. That is, aperture(s) **15042** may be of greater surface area than 5% of the surface area of external surface **1500** and may contain other device members within them (such as, for example, a fastener or interconnecting member), but the surface area of aperture(s) **15042** at its intersection with surface **1500** that contains bone forming material alone is not less than 5% of the surface area of external surface **1500**. In another embodiment, the surface area of the aperture(s) **15042** at its intersection with surface **1500** that contains bone forming material alone is greater than 15% of the surface area of external surface **1500**. In yet another embodiment, the surface area of the aperture(s) **15042** at its intersection with surface **1500** that contains bone forming material alone is greater than 25% of the surface area of external surface **1500**.

[0100] Rotational member **180** is shown in FIG. 10. Member **180** contains internal bore **1802** that accepts a pin **202**. Projections **1804** extend from bone abutment surface **1806** and contain a sharpened tip that is adapted to penetrate and anchor into bone. Side projections **1808** extend from the side of member **180** and serves to limit the extent of rotation of member **180**—as will be discussed below.

[0101] Locking nut **210** is shown in FIG. 11. Outer threads **2102** are adapted to interact with complimentary threads **1506** of member **150**. An internal indentation **2104** (hex-shaped in the illustration, but may be any applicable geometric shape) receives a complimentary driver (not shown) that can impart a rotational force onto the locking nut. Preferably, but not necessarily, the undersurface **2106** of member **210** is convex (curvilinear) so as to permit movement of member **210** relative to plate member **120**—as will be discussed below.

[0102] Bone plate **120** is shown in FIG. 12. The plate substantially has a first bone abutment surface **1202** and opposing second surface **1206**. Projections **1204** extend from bone abutment surface **1202**. Full thickness bore **1208** extends from surface **1206** to surface **1202**. Projections **130** and **132** extend from surface **1206** and serve to attach member **120** to a holding and placement—as will be described below. Projections **130** and **132** define an internal circular space **1301** which will contain locking nut **210**. In an embodiment, it will also house Belleville washers (or any other spring-like device or malleable member that functions as a spring).

[0103] Projection **130** has circular bore **1302** that extends from one side surface to the opposing side surface of projection **130**. A top opening **1304** and side opening **1306** extend into bore **1302**. Note that top opening **1304** is of smaller diameter than bore **1302**. Projection **132** is similar to **130**. It contains an internal bore **1322** with top and side openings. Note that, in a side view, bore **1302** of projection **130** is positioned closer to surface **1206** than bore **1322** of projection **132**. This permits accommodation of the holding instrument as will be described below.

[0104] FIG. 13 illustrates retaining member **195**. In an embodiment wherein a spring member (such as, for example, a Belleville washer) is placed within internal circular space **1301** and beneath the locking nut **210**, retaining member **195** functions to retain the spring member attached to plate **120**. Surface **1952** rests against locking nut **210**. The surface is curvilinear (concave) so as to cooperatively abut the curvilinear (convex) inferior surface **2106** of locking nut **210**. FIG. 14 illustrates an example of the assembled embodiment with spring member (Belleville washers **190**). An exploded view is shown in FIG. 2. Side views of plate with retaining member

195 and Belleville washers is shown in FIG. 15A, whereas a sectional view is shown in FIG. 15B.

[0105] FIG. 16 show the device during implantation with plate **120** and rotational members **180** in the “closed configuration”, whereas FIG. 17 shows them in the “open configuration”. Note that, during implantation, rotational members **180** are rotated into an “open” positioned so as to be substantially perpendicular to the longitudinal axis of member **150**. Note that protrusion **1808** limits the extent of rotation of member **180** and abuts a surface of member **150** when member **180** is fully “closed” (FIG. 16) or fully “open” (FIG. 17). The instrument that actuates and rotates member **180** applies the force needed to produces rotation at protrusion **1808**—as well be discussed further below.

[0106] Similarly, plate **120** is rotated so as to be substantially perpendicular to the longitudinal axis of member **150**. Subsequent advancement of locking nut **210** relative to threads **1506** of member **150** moves the “open” plate **120** towards the open members **180** and forcibly captures the spinous processes of an adjacent first and second vertebral bone therebetween. This will be further illustrated below.

[0107] Note that the interaction of the curvilinear surface **2106** of locking nut **206** and the curvilinear surface **1952** of member **195** with allow plate member **120** to assume a non-parallel trajectory relative to members **180**. This features permits accommodation of the local anatomical variation between adjacent spinous processes. Further, note that the advanced locking nut **210** will place a compressive load on the Belleville washers **190** between it and plate **210**. Since repeated movement between the spinous processes that are attached to the plate will cause at least some loosening of fixation protrusions **1804** and **1204** within the surrounding spinous process bone, the Belleville washers function to reload the bone/implant interface and maintain implant fixation. It should be understood that placement of loading springs between the locking nut and plate is not required for implant function, but is contemplated in an embodiment of the present disclosure. When present, the loading springs form an important feature of that embodiment—since they allow the implant to be self-tightening.

[0108] Plate member **120** is actuated to reversibly rotate from the fully “closed” to the fully “open” position by the use of instrument **230**. Instrument **230** is illustrative and it should be appreciated that any other instrument adapted to rotate member **120** may be alternatively used. The instrument **230** is a hand actuated device but may be alternatively configured to be mechanically drive, such as, for example by an attached drill. (See, for example, U.S. patent application Ser. No. 11/559,871. The application is hereby incorporated by reference in its entirety.) Instrument **230** is shown in a prospective view in FIG. 18. FIG. 19 illustrates orthogonal views while FIG. 20 shows an exploded view. Instrument **230** is comprised of a grip **232**, an articulating hand member **234**, spring members **236** and rivets **238**. Side connectors **242** connect the grip **232** to actuating member **240**. Protrusions **2402** of member **240** attach to side connectors **242**. Various pins may be used to hold different members together and are not necessarily shown in the exploded view.

[0109] Actuating member **240** has a “T” shaped distal end **2404** that is adapted to interact with segment **130** of plate **120**. Grip **232** has a separate “T” shaped distal end **2324** that is adapted to interact with segment **132** of plate **120** (see FIG. 19). Squeezing grip **232** produces the translation of end **2402** relative to end **2324** and the rotation of member **120**—as is

shown in FIG. 25. A prospective view of the actuated instrument 230 with rotated plate member 120 is shown in FIG. 23 and a section view is shown in FIG. 24. Note that the actuated instrument 230 contains channel 2303 (FIG. 24) that extends from end opening 2305 (also, see FIGS. 19 and 20) to the internal circular space 1301 of plate member 120 (FIG. 12). Channel 2303 permits the passage of locking nut 210 (attached to a screw driver) into space 1301 (posterior to retaining member 195) after plate member 120 has been rotated into the “open” configuration.

[0110] FIG. 21 illustrates end segments 2402 and 2324. FIG. 22 show the end segments interacting with plate 120. Segment 2404 has bar 24044 that extends substantially perpendicular to the long axis of member 240. Bar 24044 has radius R1 that is slightly smaller than the radius of bore 1302 of member 130 of plate 120 but greater than the size of top opening 1304. Thickness R2 is slightly smaller than the size of top opening 1304. Segment 2324 has bar 23244 having similar size relationship with bore 1322 of member 132 of plate 120. In this way, when the plate 120 is rotated into the “open” configuration of FIG. 22 (wherein the long axis of plate 120 is substantially perpendicular to the long axis of segments 2402 and 2324—FIG. 23), bar 24044 can enter and exit bore 1302 freely through top opening 1304. Similarly, bar 23244 can enter and exit bore 1322 freely through top opening 1324. However, when plate 120 is in the “closed” configuration (wherein the long axis of plate 120 is substantially oblique to the long axis of segments 2402 and 2324—FIG. 18), bar 24044 is retained in bore 1302 and bar 2344 is retained within bore 1322 so that the plate 120 cannot be detached from instrument 230.

Deployment Tubes

[0111] Illustrated are instruments used to position implant 105 at the target interspinous space.

[0112] FIG. 26A shows an exploded view of an outer member 302. Member 302 is an elongated tube that extends from a proximal end 3023 to a distal end 3021 and has an internal bore 3022. Distal protrusions 304 and 306 are positioned at the distal end whereas extension 308 is positioned at the proximal end. Full-thickness side cut 3024 and 3026 extend from the outer surface of member 302 to internal bore 3022 and contain side doors 314 and 316, respectively. Each door is attached onto outer member 302 with a pin 310. The assembled member 302 is shown in FIG. 26B with side doors 314 and 316 in the closed position. Each side door member 314 and 316 is adapted to open outwardly in reaction to an outward-directed force from within internal bore 3022. Each door may be spring loaded (spring(s) not shown) and biased toward the closed position of FIG. 26B. The assembled member 302 is shown in FIG. 26C with side doors 314 and 316 in the open position.

[0113] A cross-sectional view of member 302 is shown in FIG. 27A. Doors 314 and 316 are positioned in the open position. Internal bore 3022 contains an indentation 3021 that extends from ledge 3029 to cut-out 3025. FIG. 27B better illustrate distal protrusions 304 and 306. These protrusions are adapted to at least partially encircle the outer surface of member 150—when it is coupled to member 302. Ends 3042 and 3062 are each configured to engage and advance protrusion 1808 of member 180—so as to rotate each member 180 into the “open” position (FIG. 17).

[0114] FIG. 28B shows an oblique and section view of inner member 350. FIG. 29A shows orthogonal views of

member 350, whereas FIG. 29B illustrates a section view through the device. Member 350 extends from top surface 3504 to distal end 3507 and has internal bore 352 that is configured and sized to permit the advancement of plate 120 therethrough when it is in the closed configuration and attached to placement instrument 230 (as shown FIGS. 18 & 19). The outer surface of member 350 has threads 358 and side openings 354 and 356. Side openings cuts 354 and 356 extend from the outer surface of member 350 to internal bore 352. The proximal aspect of member 350 has a “T” handle 360. The proximal aspect of member 350 is shown in an enlarged view in FIG. 28A. Top surface 3504 contains bores 3505 that are adapted to accept a locking member. Each bore 3505 is internally contained within the segment of member 350 that extends from top surface 3504 to the distal aspect of threads 358. However, each bore 3505 is partially open distal to the distal aspect of threads 358—see FIGS. 28A and 29B.

[0115] Each locking member 370 is adapted to be at least partially contained within each bore 3505. As can be seen in FIG. 30, locking member 370 contains an elongated member having a cylindrical body 372 that extends from a proximal end 3702 to a distal end. The distal end contains protrusion 374 which is sized and configured to fit within recess 204 of member 150. The interaction of the protrusion 374 and recess 204 will be discussed further in the following sections.

[0116] FIG. 30 illustrates each locking member 370 being positioned within each bore 3505. After advancement of member 370 through bore 3505, proximal end 3702 projects above top surface 3504 of member 350 as seen in FIG. 31. A Gear member 382 is attached onto proximal end 3702 and affixed using any known method for component fixation (such as, for is example, brazing, adhesives, press fit, thermal techniques and the like). Member 390 is positioned onto top surface 3504, wherein member 390 has internal serrations that interact with each of gears 382 in a planetary gear—like arrangement. Member 390 is retained onto member 350 by pins 3902—which are retained within cut out 3904 of member 390 and function to also limit the extend of rotation of member 390. The assembled device is shown in FIG. 32. Note that the protrusion 374 of each member 370 extends inwards and towards internal bore 352 of member 350 when member 390 is in the illustrated position. (In contradistinction, protrusion 374 of each member 370 extends outward and away from internal bore 352 of member 350 when member 390 is in the position shown in FIG. 35.)

[0117] With protrusion 374 of each member 370 extending towards internal bore 352 of member 350, outer member 302 can be coupled with inner member 350 as shown in FIG. 33. Nut 402 has a knurled external surface and a central bore. The central bore has threads 4022 that are adapted to cooperatively engage threads 358 of member 350. When member 350 and 302 are coupled, rotation of nut 402 relative to threads 358 in a first direction will cause member 302 to travel along member 305 in a first longitudinal direction. Conversely, rotation of nut 402 relative to threads 358 in an opposite direction will cause member 302 to travel along member 305 in an opposite longitudinal direction. Note that cylindrical body 372 of locking member 370 is at least partially contained within indentation 3021 of member 302 and protrusion 374 is configured to fit within cut-out 3025 of member 302 (see FIG. 36).

[0118] FIGS. 34-37 illustrate the assembled outer member 302 and inner member 350. FIG. 37 shows sectional views. In FIGS. 34 and 36B, member 390 is rotated into a “locked”

position, wherein protrusion 374 of each member 370 extends inwards and towards internal bore 352 of member 350. In FIGS. 35 and 36A, member 390 is rotated into an “unlocked” position, wherein protrusion 374 of each member 370 extends outward and away from internal bore 352 of member 350. Note that member 390 must be in the “unlocked” position in order to couple implant 105 to the assembly. Further, when member 390 is in the “unlocked” position, outer member 302 and member 350 are locked together and prevented from movement relative to one another along the longitudinal direction.

Method of Device Placement—

[0119] The implantation of the fixation devices will now be described. As mentioned above, the devices perform a spacing function as well as the compression and fixation of adjacent spinous processes such that the spinous processes of the implanted vertebral bones are locked in position relative to one another. That is, the device enlarges the target interspinous space by increasing the distance from the inferior surface of the superior spinous process to the superior surface of the inferior spinous process, wherein the superior and inferior spinous processes are the spinous processes that border and define the target interspinous space.

[0120] It should be appreciated that the fixation device described herein may be used with any surgical approach to the posterior aspect of the spine and the disclosed fixation device can be positioned in the spine using any appropriate surgical method and/or surgical corridor. The fixation device described herein is particularly adapted to be placed through a lateral surgical approach to the spine that starts with a surgical incision in the posterior aspect of the patient’s flank (i.e., side aspect of the abdominal cavity). The fixation device described herein is also particularly adapted for use in stabilizing the posterior aspect of a spinal segment when a second orthopedic implant is implanted into the disc space of that segment using a lateral, or flank, approach to the disc space. It must be noted that while the lateral approach is employed in one method of use, the implantation procedure of the device is by no means limited to a lateral approach to the interspinous space.

[0121] In an embodiment, the fixation devices are implanted into the lumbar spine using a flank incision and a lateral approach—which is now described. The spinal level of desired device implantation can be localized under imaging guidance (such as, for example, using X-rays). Referring to FIG. 5, a skin incision can be placed in the flank at the approximate cephalad-caudal level of the implantation site on the spine. FIG. 5 illustrates a cross sectional view of the torso at the level of the lumbar spine. For clarity of illustration, the contents are represented schematically and those skilled in the art will appreciate that an actual cross section of the human torso may include anatomical details not shown in FIG. 5.

[0122] In preparation for percutaneous placement of the implant into a spinal level, the patient can be, but is not necessarily, placed in a prone or lateral decubitus position. The level of the spine that is to be implanted can be localized on X-ray in at least one plane. After the customary sterile preparation of the operative site, the surgeon can localize an incision point on the skin that is substantially directly lateral to the spinal segment that will be implanted. FIG. 6 shows a schematic representation of the posterior aspect of a patient. The skin overlying the back is shown. Lines Y show the lateral

extent of the fact joints of the spinal column. Assuming that the spinal level to be accessed is at line Z, the surgeon can make an incision at or about circle X.

[0123] A lateral corridor “Y” (FIG. 5) can be made from the flank, through the psoas muscle 116 and onto the lateral aspect of the disc space at the spinal level to be implanted. An implant can be placed through the corridor Y and into disc space or onto the spine. The procedure is known to those skilled in the art and known as the “XLIF” procedure. (Once again, see “Extreme Lateral Interbody Fusion (XLIF): a novel surgical technique for anterior lumbar interbody fusion” by Ozgur, Aryan et al. in *Spine J.* 2006 July-August; 6(4):435-43, which is hereby incorporated by reference in its entirety.)

[0124] A second lateral corridor “Z” (FIG. 5) can be made from the flank, through the posterior tissues lateral to the spine and onto the lateral aspect of the spinous processes and interspinous ligament of the level to be implanted. While Corridor Y and Corridor Z are shown schematically as exiting the skin of the flank at two different sites, both corridors can be made through a single, common skin incision on the patient’s flank. Once through the skin, the trajectory can be then varied so as to form an anatomically anterior Corridor Y and an anatomically posterior Corridor Z. The device disclosed herein can be implanted into the posterior aspect of a functional spinal unit using a Corridor Z and, at the same operation, an implant can be placed into or onto the anterior column (including disc space) of the same functional spinal unit using a Corridor Y.

[0125] The totality of the operation—from selection of the target level to implant to the final placement of implant—can be performed under image guidance. Further, the operation can be performed using percutaneous or minimally invasive surgical techniques with or without the aid of electrophysiological monitoring. The later include techniques such as electromyography (EMG) and are intended to alert the operating surgeon to the presence of nerves and other neural elements within the surgical corridor. EMG identification of nerves permits the surgeon to navigate the surgical site with increased safety and to lessen the possibility of nerve injury.

[0126] After placement of lateral/flank skin incision (at or about “X” of FIG. 6), cylindrical tissue dilator are advanced through the incision and used to create a corridor (such as, for example, corridor z of FIG. 5) to the interspinous space of the target segment. The tract is sequentially dilated to the desired size. The technique of expanding a tissue corridor by the sequential placement of progressively larger tubes is known in the art, and was also disclosed by Abdou in U.S. patent application Ser. No. 12/940,960 (the application is hereby incorporated by reference in its entirety). After tract dilatation, the outer-most tube (or expandable tissue dilator, as shown in application Ser. No. 12/940,960) is retained whereas all the smaller-sized dilation tubes are removed. The internal aspect of the retained tube forms a corridor to the lateral aspect to the target interspinous space.

[0127] The target space is accessed and the interspinous ligament contained therein is cut and/or perforated. At least a segment of each of the two spinous processes that border the target interspinous space is decorticated (wherein the decorticated segments also form a border of the target interspinous space). The decortication step prepares the bone of each spinous process for the formation of a fusion mass with the spinous process. (For clarity of illustration, the vertebral bones are not illustrated in the accompanying drawings.)

[0128] The internal aspect of housing member 150 is filled with bone forming material. The bone forming material is placed to substantially fill the internal bore 1504 of member 150. With rotation members 180 in the “closed” position, the device is attached to the tube assembly of outer member 302 and member 350—as shown in FIGS. 38 and 39. Note that member 390 must be in the unlocked position in order to attach member 150 (FIG. 38). After member 150 is placed inside of the space between protrusions 304 and 306, member 390 is rotated to the “closed” position which rotates the protrusion 374 of each member 370 into a recess 204 of member 150 (FIG. 39). It should be noted that when member 150 is rigidly attached to the tube assembly, member 150 is positioned with end 1501 abutting distal end 3507 of member 350. Further, ends 3062 of protrusion 306 and ends 3042 of protrusion 304 are abutting projections 1808 of rotational members 180. Note that the engagement between the ends 3062 of protrusion 306 and the ends 3042 of protrusion 304 with the projections 1808 of the rotational members 180 are located on the external surface of member 150. That is, the engagement between the impartment placement device and the rotational members 180 in one embodiment comprises an abutment of the external surface (1500 and 1503) of member 150, and is not within the internal aspect of member 150. This feature permits maximization of the internal space for placement of the bone forming material.

[0129] It is this embodiment, the direct external engagement between member 302 of the tube assembly and the rotational members 180 forcibly rotates members 180 at the time of implantation (as will be discussed below). In one variant, member(s) 180 is not rotated through a direct internal engagement mechanism between a segment of the implant placement devices (of the tube assembly) and the rotational members, nor through the use of a linkage that is wholly contained within the internal aspect of member 150.

[0130] The tube assembly and the attached implant are then advanced to the target interspinous space (through the cylindrical tube that forms corridor Z). “T” handle 360 permits the surgeon to control the implantation process. The distal end of the implant is advanced across the target interspinous space until the free end of each rotation member 180 is positioned on the contralateral side of the spinous processes that border the target interspinous space. (Note that the ipsilateral side of the spinous processes is on the same side of the sagittal midline of the subject as the site of the skin incision of device insertion. Conversely, the contralateral side of the spinous processes is on the opposite side of the sagittal midline of the subject as the site of the skin incision.) At the time of advancement across the target interspinous space, members 180 are purposely angled relative to member 150 so as to form an arrow-like configuration. In this way, the free end of each member 180 would be captured on the contralateral side of the spinous process and unable to return across the interspinous space.

[0131] After members 180 are positioned on the contralateral side of the spinous processes, knurled nut 402 is rotated. As member 302 is advanced relative to member 350, distal protrusions 304 and 306 of member 302 forcibly rotate rotation members 180—as shown in FIG. 40. Nut 402 is advanced further until each of the two spinous process that border the target interspinous space are captured between the rotated (“Open”) rotation member 180 and the distal end 3021 of member 302 (see FIG. 41).

[0132] Instrument 230 with attached plate 120 (in the “closed” position) is advanced into internal bore 352 of member 350. This is illustrated on FIGS. 42 and 43A. FIG. 43B shows a cross-sectional view with the instrument 230/plate 120 in place. Instrument 230 is actuated in order to rotate plate 120 and position it substantially parallel to the “open” rotation members 180. This is shown in FIG. 44A and in a cross-sectional view in FIG. 44B. Note that channel 2303 provides an open corridor for the placement of locking nut 210 there-through. FIG. 45 illustrates locking nut 210 being attached to screw-driver 425 and then advanced into channel 2303 of instrument 230 through opening 2305. As locking member 210 engages threads 1506 on member 150, it is rotationally advanced relative to member 150 and it pushes the rotated plate 120 into the ipsilateral side of the captured spinous processes. Note that advancing plate 120 within central bore 1504 of member 150 also compacts the bone graft material contained therein and forces said graft material out of the open sides of central bore 1504 and into certain contact with the decorticated spinous process segments that border the implantation site. This is an important feature of the present disclosure and it functions to guarantee contact of the bone graft material with the adjacent spinous processes. Further, the compressive load placed on the bone graft material will improve the likelihood of bone fusion, since compressive load is a known stimulant of bone formation.

[0133] Continued advancement of locking nut 210 forcibly drives the projections 1804 of member 180 and the projections 1204 of plate 120 into opposing sides of the captured spinous processes. FIG. 47 shows the implant with plate 120 having been advanced and screw driver 425 having been removed.

[0134] In order to remove the tube assembly of member 302 and member 350, knurled nut 402 is rotated back fully relative to threads 358 (FIG. 48). Member 390 is then rotated into the “open” position so that protrusion 374 of each member 370 extends outward and away from internal bore 352 of member 350. In this way, protrusions 374 disengage from member 150. (Note that member 390 cannot be rotated into the “open” position until knurled nut 402 is rotated back fully relative to threads 358.)

[0135] After removal of the tube assembly, the cylindrical tube used to form and maintain corridor Z is removed. Implant 105 (FIG. 49) is left at the target interspinous space.

[0136] Note that the implanted device 105 has a number of novel properties. The implant contains an internal cavity that is sized and configured to house a bone graft material and the enclosed material is able to contact the decorticated surfaces of both spinous processes that border the implanted interspinous space. That is, the spinous processes can fuse together and form a continuous bony bridge that extends from one side surface of the implant through the internal aspect of implant 105 and onto an opposing side surface of the implant. As noted, the internal cavity may in one embodiment be at least 20% of volume of the implant 105. Advancement of member 120 functions as a plunger that compacts the enclosed bone graft material and pushes it of the device and onto the prepared bony surface of the adjacent spinous processes. However, it should be noted that the device may be alternatively (or additionally) coated/made with osteo-conductive (such as demineralized bone matrix, hydroxyapatite, nanotube surface (such as Titanium Oxide) and the like) and/or osteo-inductive (such as Transforming Growth Factor “TGF- β ,” Platelet-Derived Growth Factor “PDGF,” Bone-Morpho-

genic Protein “BMP,” and the like) bio-active materials that promote bone formation. In this way, a mineralized (bony) bond is made between the each of the two device-abutting spinous processes and the implant instead of (or in addition to) a direct mineralized bony fusion between the spinous processes.

[0137] An additional novel feature of the implant is use of the Belleville washers (or any appropriate spring/malleable member) to re-load the implant/bone interface in event of fixation member loosening. Finally, the implant accommodates individual variations in bone anatomy by permitting plate 120 to rest in a non-parallel trajectory relative to members 180. This is accomplished by the interaction of the curvilinear surface 2106 of member 210 (FIG. 11) and the curvilinear surface 1952 of retainer 195.

[0138] Another method of device use is shown in FIG. 50. In this embodiment, a portion of the facet joint is removed and a bone fusion implant is placed into the anterior column through the cavity created by the facet resection. This operation is known to those of ordinary skill in the art as a Transforaminal Lumbar Interbody Fusion (TLIF). A bone screw 1545 can be placed into the pedicle portion of bone at each of the upper (L4 level) and lower (L5 level) vertebral bones. A rod 1560 can be used to rigidly interconnect the screws 1545. The screws/rod can be placed on one side of the vertebral midline and a fixation device 105 can be used to supplement the uni-lateral screw/rod fixation. In one method of use, the implant 105 is implanted through the same (single) skin incision used to implant the screws 1545 and inter-connecting rod 1560.

[0139] FIG. 7A shows a schematic illustration of the approximate location of incision site “X” for the TLIF procedure. A soft tissue corridor “J”, which extends from incision “X” to the underlying bone, is shown in FIG. 7B. In a first embodiment, all implants are placed ipsilateral to the skin incision “X”, wherein an implant 1546 is positioned into the disc space of the anterior column, two screws 1545 and an interconnecting rod 1560, as well as interspinous implant 105 are collectively delivered through corridor “J”. A separate contralateral skin incision is not needed, since placement of device 105 obviates the need to place bone screws on the contralateral side of the spinous process. However, it is further contemplated that a separate skin incision can be made on the contralateral side of the spinous processes and bone screws (or other orthopedic implants) may be placed into the vertebral bones on the contralateral side of the spinous process—if the surgeon so desires.

[0140] FIGS. 51-55 disclose an alternative embodiment to plate 120. Instead of the unitary plate 120 disclosed above, member 530 is comprised of multiple segments that include two rotatable door member 535 and interconnecting housing 538. Door members 535 are connected to housing 538 via pins 536. Housing 538 contains an internal cut out 5382 that is sized and configured to at least partially contain locking nut 545. Locking nut 545 has external threads that cooperatively engage complimentary threads 1506 of member 150. While cut out 5382 is shown containing locking nut 545 alone, it is contemplated that Belleville washers, spring member or any other appropriate malleable member may be additionally placed within cut out 5382—as was disclosed for plate 120. When Belleville washers are included, they are positioned to abut surface 53822 of cut out 5382 and to rest between locking nut 545 and said surface 5382. In this way, the Belleville washers would exert a force that retightens the device-bone

interface between door member 535 (and spikes 5352) and the adjacent bone in the event of loosening. This feature was fully discussed for plate 120.

[0141] FIG. 51 illustrates member 530 with door members 535 in the “closed” position, whereas FIG. 52 shows an exploded view. FIG. 53 shows member 530 with door member 535 in the “open” position.

[0142] Member 105 is advanced through the insertion corridor to the target interspinous space with member 530 attached to member 150—and with door members 535 in the “closed” position. This configuration is shown in FIG. 54 (the deployment tubes are not shown). Note that corner 5354 of door 535 overlaps end surface 1501 of member. It is this corner interaction and interference that produces door rotation into the “open” position.

[0143] After the device is positioned at the target interspinous space, locking nut 545 is rotationally advanced relative to threads 1506 of member 150. Doors 535 are forcibly rotated by surface 150 so that member 530 is in the “open” position—as shown in FIG. 55. Note that side surfaces 1503 of member 150 retain member 530 in the “open” position. Close-up views of the “closed” to “open” door transition are shown in FIG. 56.

[0144] The disclosed devices or any of their components can be made of any biologically adaptable or compatible materials. Materials considered acceptable for biological implantation are well known and include, but are not limited to, stainless steel, titanium, tantalum, combination metallic alloys, various plastics (such as PEEK and the like), resins, ceramics, biologically absorbable materials and the like. Any components may be also coated/made with osteo-conductive (such as demineralized bone matrix, hydroxyapatite, and the like) and/or osteo-inductive (such as Transforming Growth Factor “TGF- β ,” Platelet-Derived Growth Factor “PDGF,” Bone-Morphogenic Protein “BMP,” and the like) bio-active materials that promote bone formation. Further, any surface may be made with a porous ingrowth surface (such as titanium wire mesh, plasma-sprayed titanium, tantalum, porous CoCr, and the like), provided with a bioactive coating, made using tantalum, and/or helical rosette carbon nanotubes (or other carbon nanotube-based coating) in order to promote bone in-growth or establish a mineralized connection between the bone and the implant, and reduce the likelihood of implant loosening. Lastly, the system or any of its components can also be entirely or partially made of a shape memory material or other deformable material.

[0145] Certain features that are described in this specification in the context of separate embodiments can also be implemented in combination in a single embodiment. Conversely, various features that are described in the context of a single embodiment can also be implemented in multiple embodiments separately or in any suitable sub-combination. Moreover, although features may be described above as acting in certain combinations and even initially claimed as such, one or more features from a claimed combination can in some cases be excised from the combination, and the claimed combination may be directed to a sub-combination or a variation of a sub-combination. Similarly, while operations are depicted in the drawings in a particular order, this should not be understood as requiring that such operations be performed in the particular order shown or in sequential order, or that all illustrated operations be performed, to achieve desirable results. Only a few examples and implementations are disclosed. Variations, modifications and enhancements to the

described examples and implementations and other implementations may be made based on what is disclosed.

What is claimed is:

1. An orthopedic implant, comprising:
 - an elongated body configured to extend along a longitudinal axis from a first proximal segment to a second distal segment, the elongated body comprising an internal bore configured to:
 - accept a bone forming material therein;
 - occupy at least a portion of an internal volume of the elongated body; and
 - comprise at least one aperture configured to open onto an outer surface of the elongated body;
 - at least one rotational bone abutment member configured to attach to the second distal segment of the elongated body and configured to rotate from a first orientation to a second orientation relative to the elongated body;
 - at least one second bone abutment member configured to attach to the first proximal segment of the elongated body; and
 - a locking mechanism positioned at the first proximal segment of the elongated body, the locking mechanism configured to be advanced in a first direction to produce movement of the at least one second bone abutment member towards the at least one rotational bone abutment member;
 - wherein advancement of the locking mechanism in a second direction permits movement of the at least one second bone abutment member away from the at least one rotational bone abutment member.
2. The orthopedic implant of claim 1, wherein the at least one rotational bone abutment member comprises at least one protrusion configured anchor onto bone.
3. The orthopedic implant of claim 2, wherein the advancement of the locking mechanism in the first direction produces forceful advancement of the at least one protrusion onto a bony segment positioned between the at least one rotational bone abutment member and the second bone abutment member.
4. The orthopedic implant of claim 1, wherein the at least one second bone abutment member comprises at least one protrusion configured to anchor onto bone.
5. The orthopedic implant of claim 4, wherein the advancement of the locking mechanism in the first direction produces forceful advancement of the at least one protrusion onto a bony segment positioned between the at least one rotational bone abutment member and the second bone abutment member.
6. The orthopedic implant of claim 1, further comprising a placement instrument configured to produce rotation of the rotational bone abutment member as the locking mechanism is advanced in the first direction.
7. A method for the percutaneous decompression of a spinal canal, comprising:
 - identifying on an imaging technique a spinal level to be implanted;
 - making an incision lateral to a vertebral midline;
 - advancing an orthopedic implant into an interspinous space of the spinal level to be decompressed, the orthopedic implant comprising an elongated body having an internal bore configured to accept a bone forming material therein, the internal bore occupying at least a portion

- of an internal volume of the elongated body and having an aperture opening onto an outer surface of the elongated body;
 - attaching at least one rotational bone abutment member to a distal segment of the elongated body of the orthopedic implant, the at least one rotational bone abutment member configured to rotate from a first orientation to a second orientation relative to the elongated body;
 - attaching at least one second bone abutment member to a proximal segment of the elongated member;
 - positioning a locking mechanism at the proximal segment of the elongated body; and
 - advancing the locking mechanism along a first direction to produce movement of the at least one second bone abutment member towards the at least one rotational bone abutment member and capturing a spinous process of each vertebral bone abutting the implanted inter-spinous space between the at least one rotational bone abutment member and the at least one second bone abutment member;
 - wherein advancement of the locking mechanism in a second direction opposing the first direction permits movement of the at least one second bone abutment member away from the at least one rotational bone abutment member.
8. A method for treatment of a spinal segment, the spinal segment comprising first and second adjacent spinous processes, the method comprising:
 - positioning a bone forming material within an internal bore of an orthopedic implant, the internal bore comprising at least 20% of an internal volume of the orthopedic implant and the bone forming material being configured to fuse with at least one of the first and second spinous processes;
 - advancing a first segment of the orthopedic implant from a first ipsilateral side to a second contralateral side of an interspinous ligament that interconnects the first and second spinous processes, the first segment comprising a segment of an elongated body and at least a first bone abutment member coupled to the elongated body;
 - rotating the first bone abutment member relative to the elongated body, the rotated first bone abutment member being at least partially positioned within the second contralateral side of the interspinous ligament;
 - causing a surface of a second bone abutment member to abut a side surface of at least one of the first and second spinous processes, the second bone abutment member being at least partially positioned within the first ipsilateral side of the interspinous ligament;
 - translating the second bone abutment surface towards the first bone abutment surface by advancement of a locking mechanism of the orthopedic implant; and
 - causing a forceful immobilization of at least one of the first and second spinous processes between the first and the second one abutment members.
 9. The method of claim 8, wherein the forceful immobilization of at least one the first and second spinous processes causes at least one protrusion of one of the first and second abutment surfaces to anchor onto bone.
 10. A kit for positioning an orthopedic implant within a subject, the kit comprising:
 - an orthopedic implant comprising an elongated body extending along a longitudinal axis from a first proximal segment to a second distal segment, the elongated body

comprising an external surface and an internal bore configured to occupy at least twenty percent of an internal volume of the elongated body, the internal bore further comprising an aperture configured to open onto the external surface;

at least one rotatable bone abutment member attached to the second distal segment of the elongated member and configured to rotate from a first orientation to a second orientation relative to the elongated body, the at least one rotatable bone abutment member comprising an external surface positioned along the external surface of the orthopedic implant; and

at least one elongated implant placement device configured to reversibly couple to the first proximal segment of the orthopedic implant, the at least one elongated implant placement device further configured to forcibly rotate the at least one rotatable bone abutment member from the first to the second orientation relative to the elongated body through an application of a force transmitted directly from the at least one elongated implant placement device to the external surface of the at least one rotatable bone abutment member.

* * * * *