



US010175515B2

(12) **United States Patent**
Oka et al.

(10) **Patent No.:** **US 10,175,515 B2**

(45) **Date of Patent:** **Jan. 8, 2019**

(54) **IMAGE DISPLAY DEVICE**

(71) Applicant: **Japan Display Inc.**, Tokyo (JP)

(72) Inventors: **Shinichiro Oka**, Tokyo (JP); **Toshinari Sasaki**, Tokyo (JP)

(73) Assignee: **Japan Display Inc.**, Tokyo (JP)

(*) Notice: Subject to any disclaimer, the term of this patent is extended or adjusted under 35 U.S.C. 154(b) by 18 days.

(21) Appl. No.: **15/448,681**

(22) Filed: **Mar. 3, 2017**

(65) **Prior Publication Data**

US 2017/0269421 A1 Sep. 21, 2017

(30) **Foreign Application Priority Data**

Mar. 17, 2016 (JP) 2016-054001

Aug. 29, 2016 (JP) 2016-166470

(51) **Int. Cl.**

G02F 1/1333 (2006.01)

G02F 1/1368 (2006.01)

G02F 1/1362 (2006.01)

G02F 1/1345 (2006.01)

G02F 1/1343 (2006.01)

(52) **U.S. Cl.**

CPC **G02F 1/133305** (2013.01); **G02F 1/1368** (2013.01); **G02F 1/13452** (2013.01); **G02F 1/136209** (2013.01); **G02F 1/134363** (2013.01); **G02F 2001/13685** (2013.01)

(58) **Field of Classification Search**

CPC G02F 2001/133308; G02F 2001/133314;

G02F 2001/133317; G02F 2001/133322

See application file for complete search history.

(56) **References Cited**

U.S. PATENT DOCUMENTS

2008/0198298 A1* 8/2008 Jeong F41J 3/02 349/65

2015/0362812 A1 12/2015 Aoki et al.

FOREIGN PATENT DOCUMENTS

JP 2001-264751 A 9/2001

JP 2003-195288 A 7/2003

JP 2007-065270 A 3/2007

JP 2016-004071 A 1/2016

* cited by examiner

Primary Examiner — Phu Vu

(74) *Attorney, Agent, or Firm* — Typha IP LLC

(57) **ABSTRACT**

An image display device includes a first substrate; a second substrate located to face the first substrate; an electro-optical layer between the first substrate and the second substrate; a plurality of pixel electrodes located between the electro-optical layer and the first substrate; a plurality of switching elements electrically connected with the plurality of pixel electrodes respectively; and a color filter included in a layer between the first substrate and the plurality of switching elements. A side of the first substrate opposite to a side thereof facing the electro-optical layer is an image display side.

18 Claims, 15 Drawing Sheets

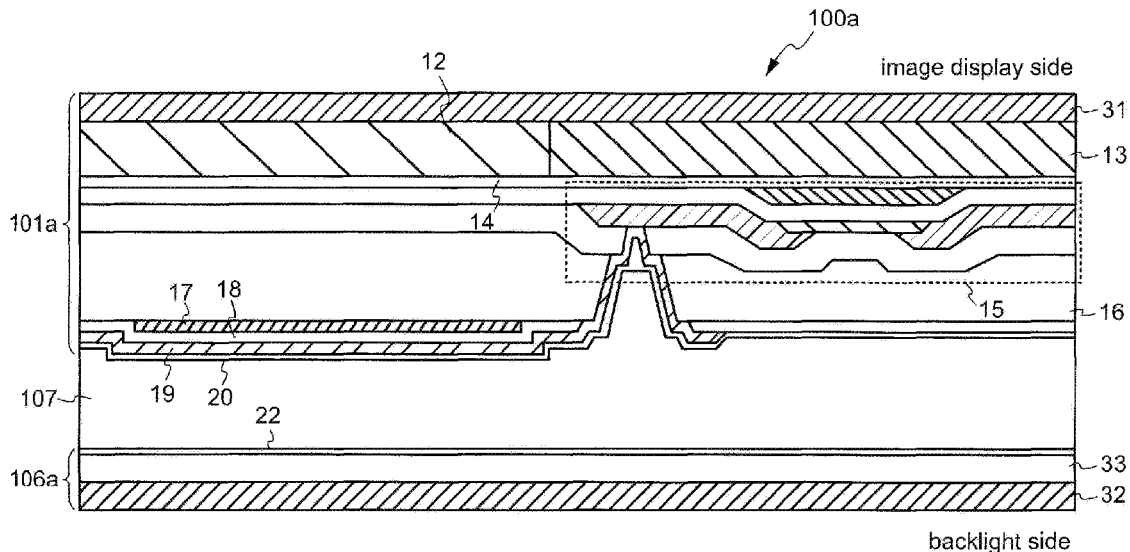

FIG. 1

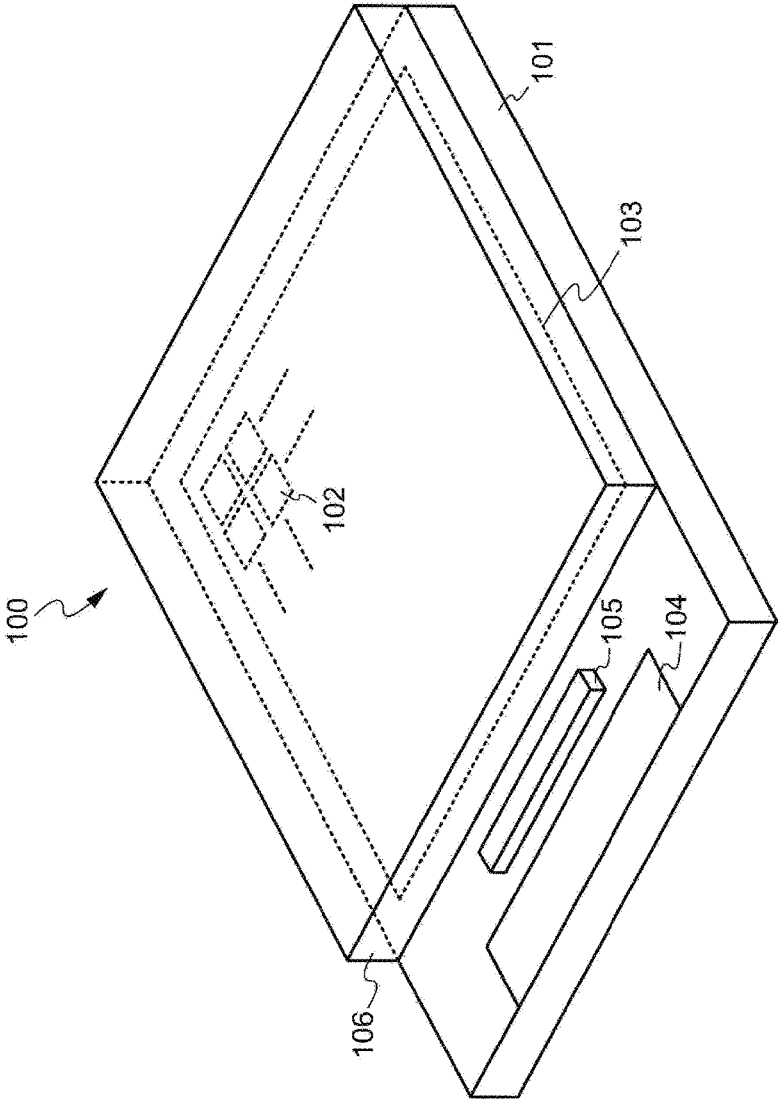

FIG. 2

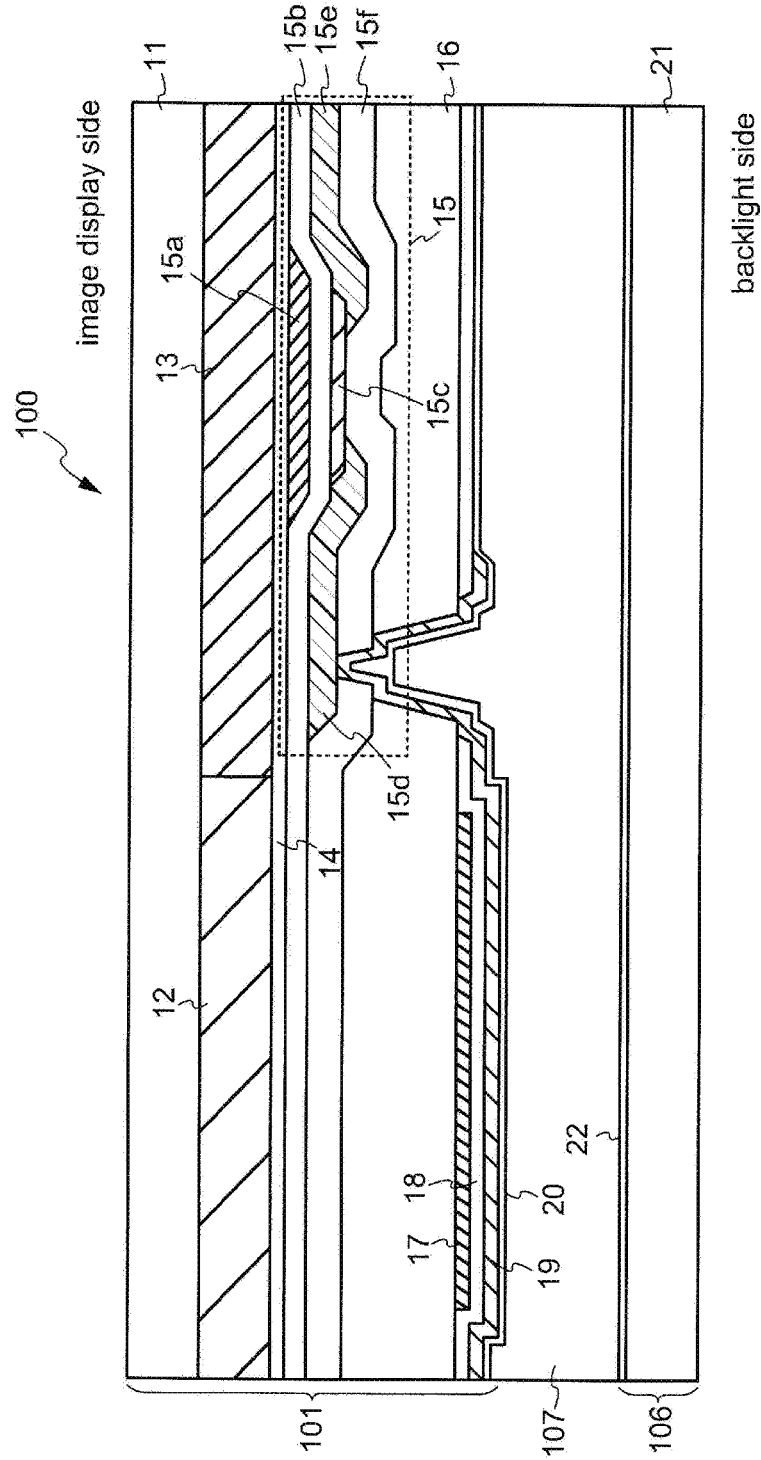

FIG.3

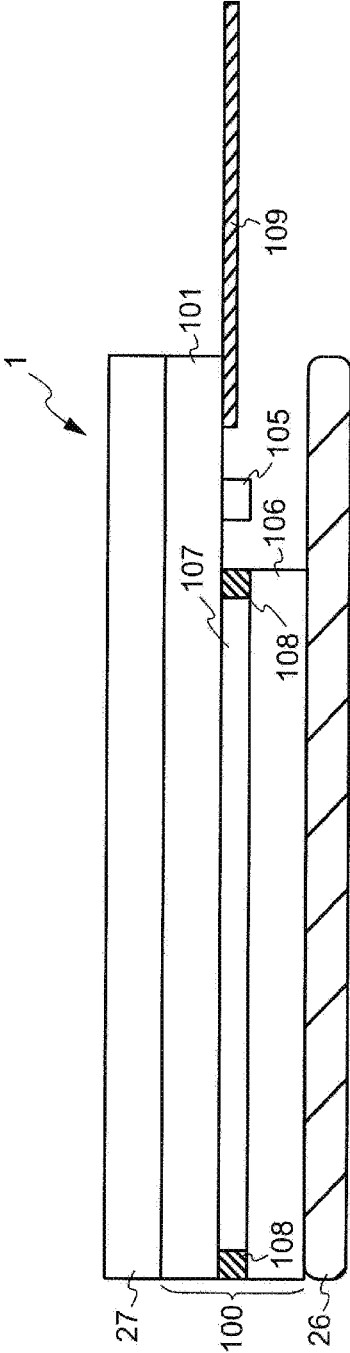

FIG. 4

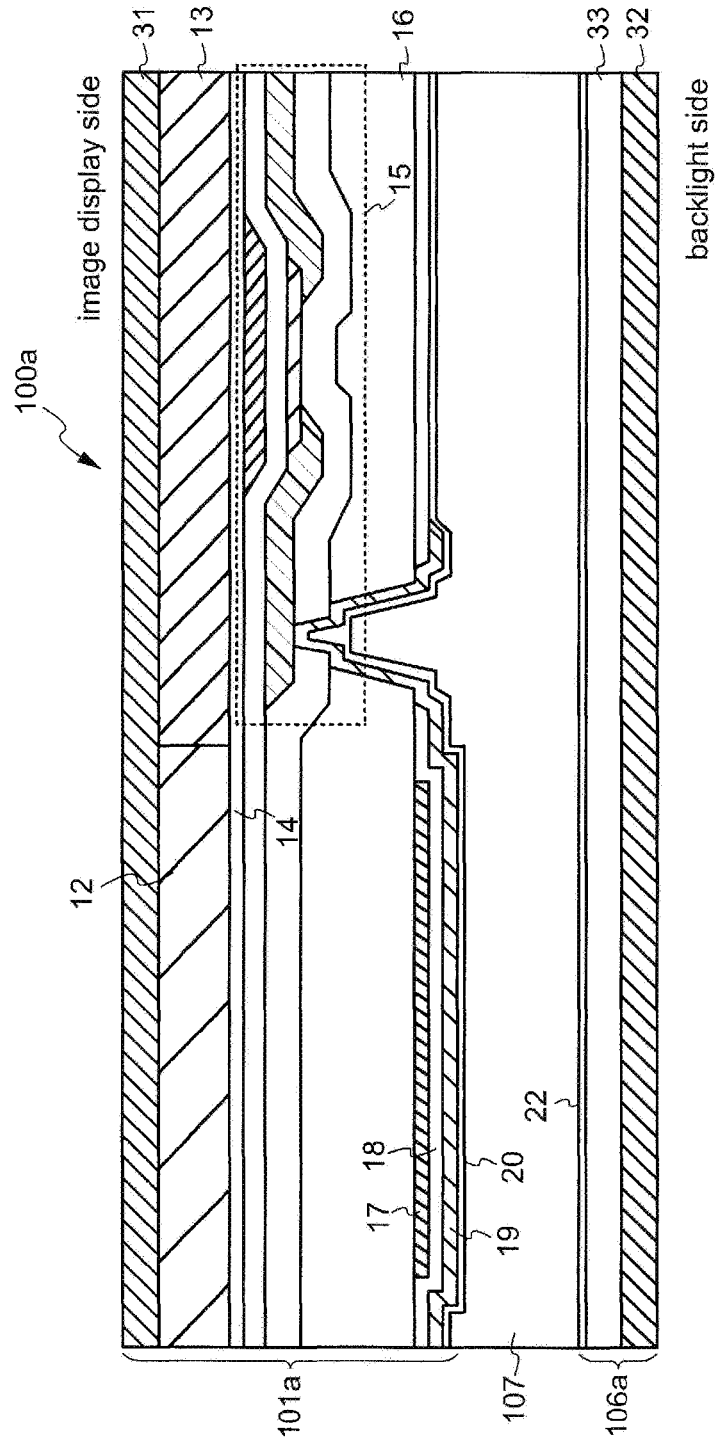

FIG. 5

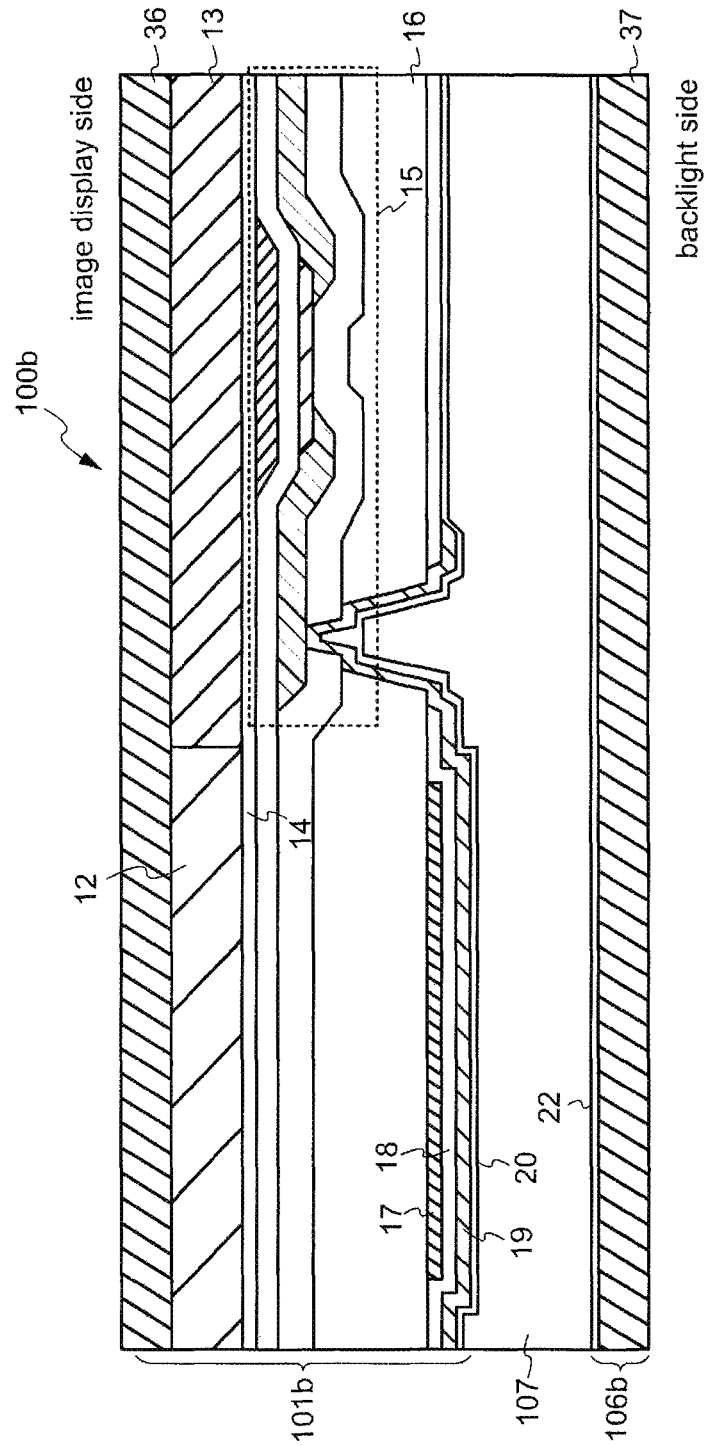

FIG. 6

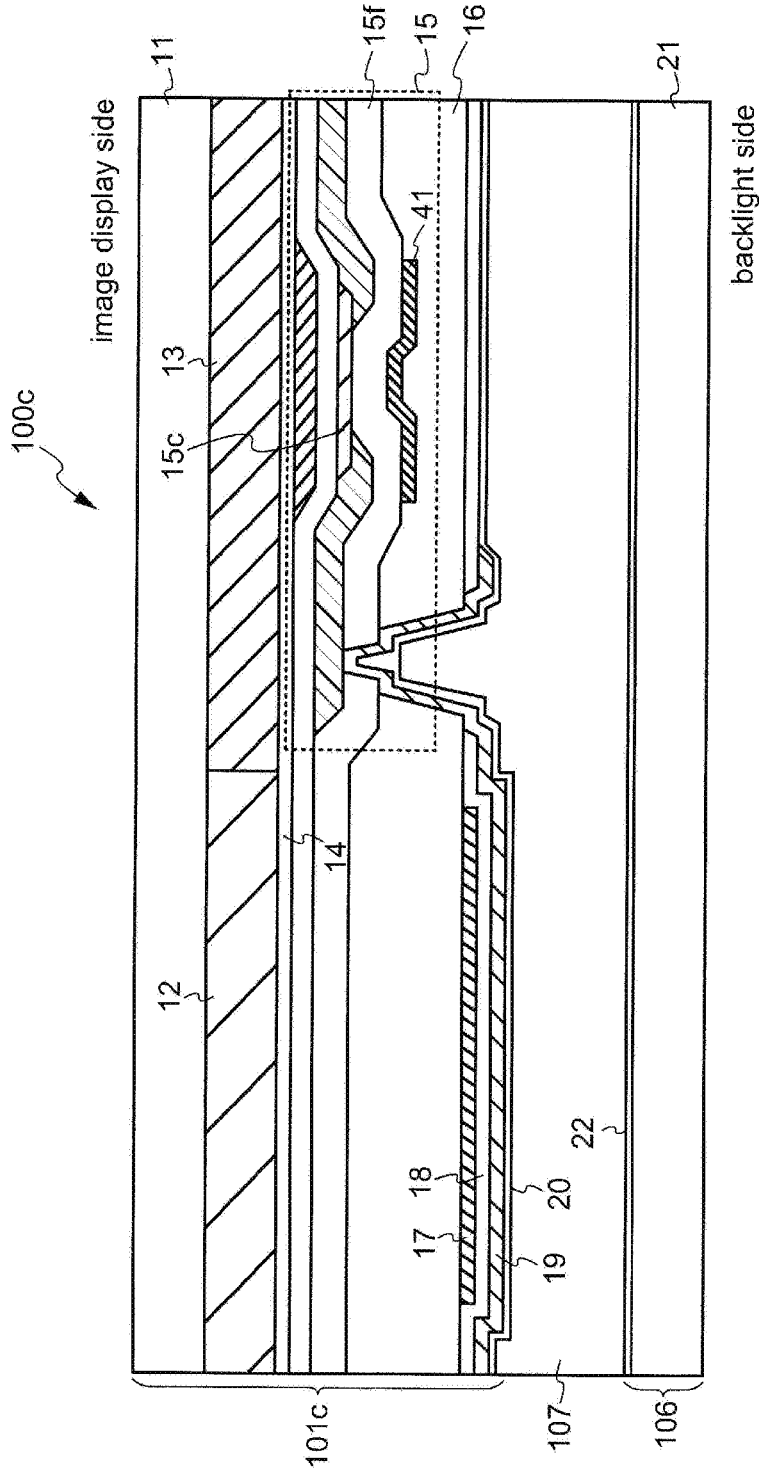

FIG. 7

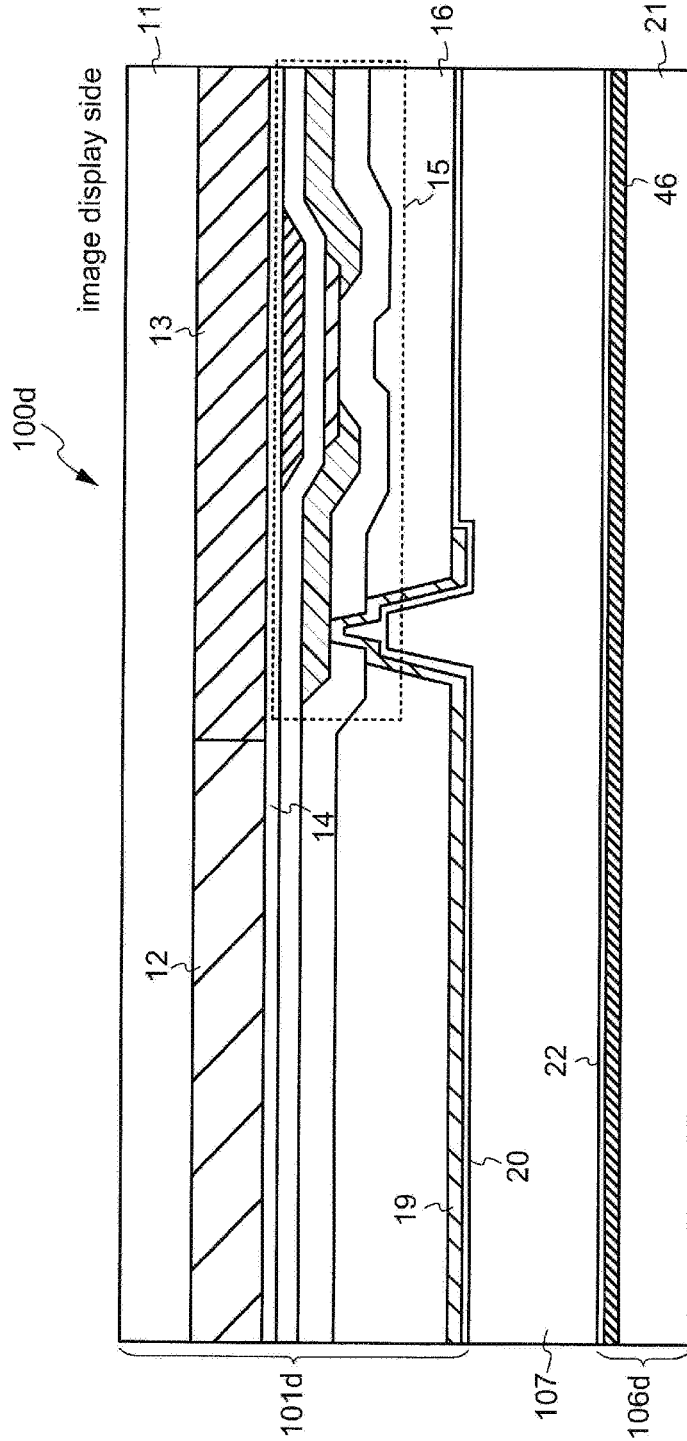

FIG. 8

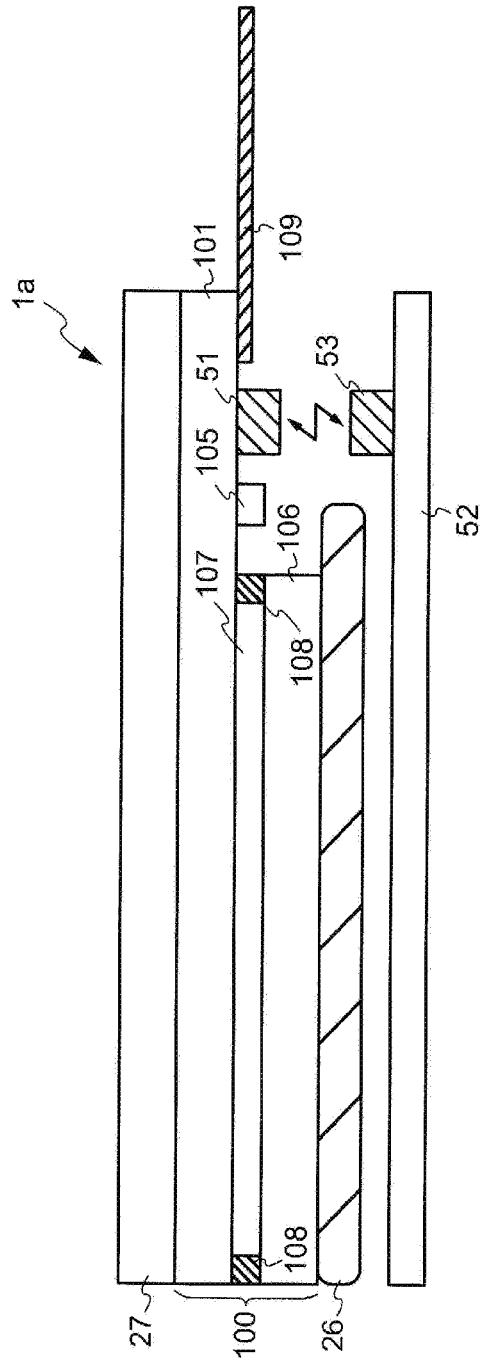

FIG. 9

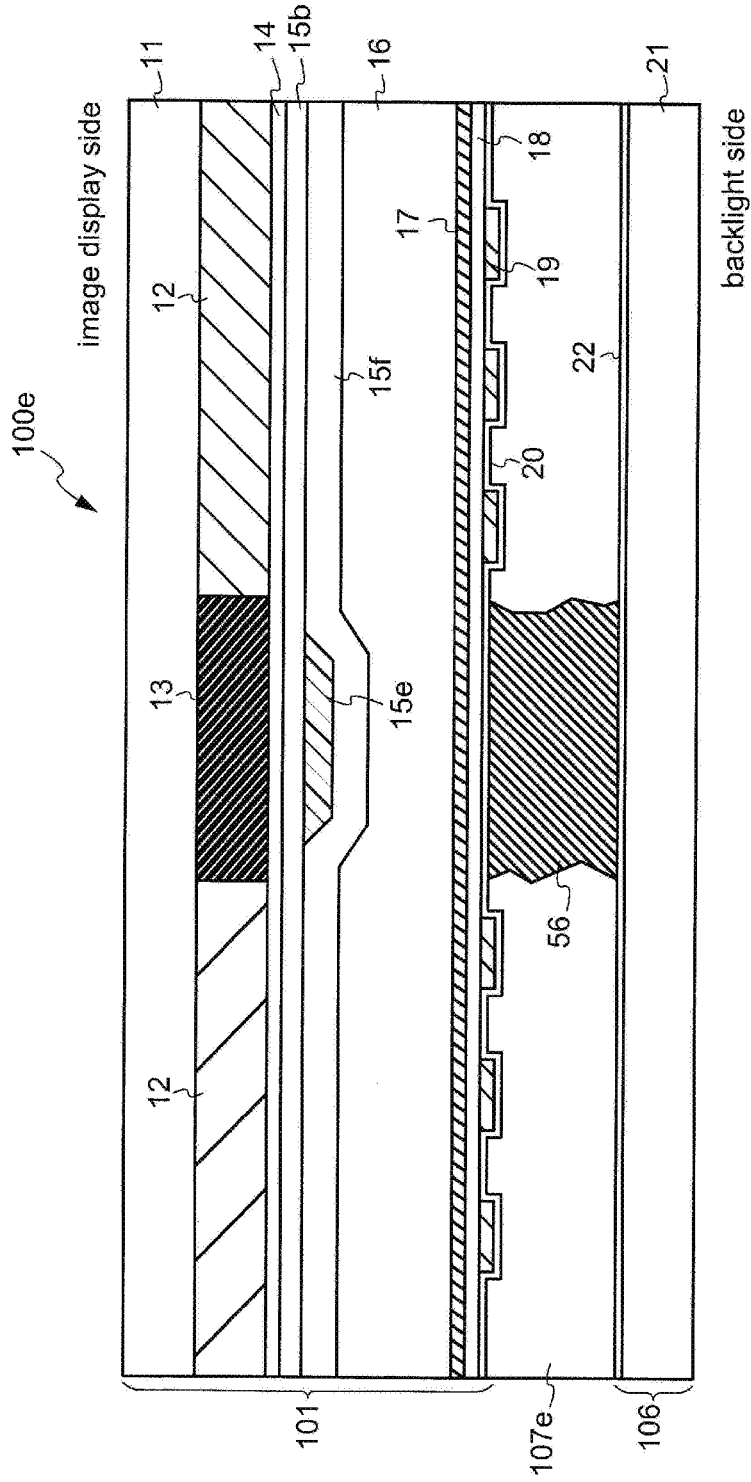

FIG. 10

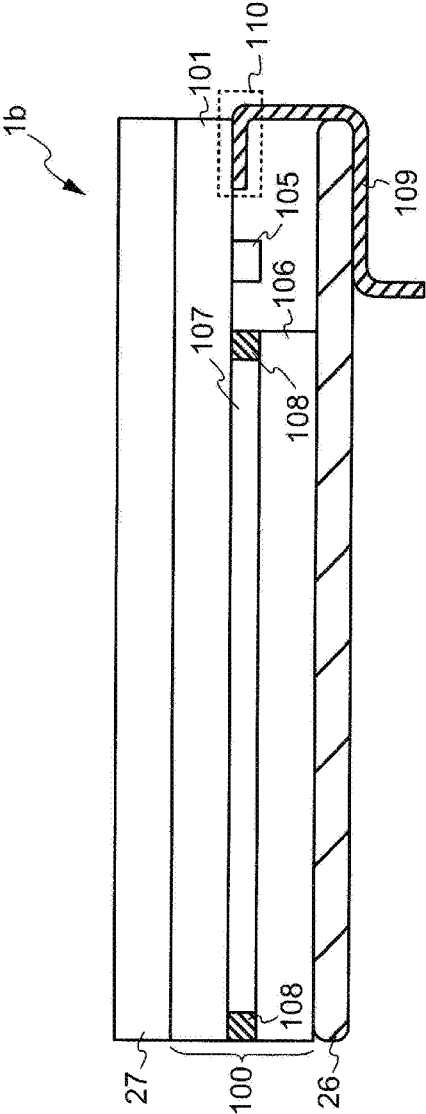

FIG. 11

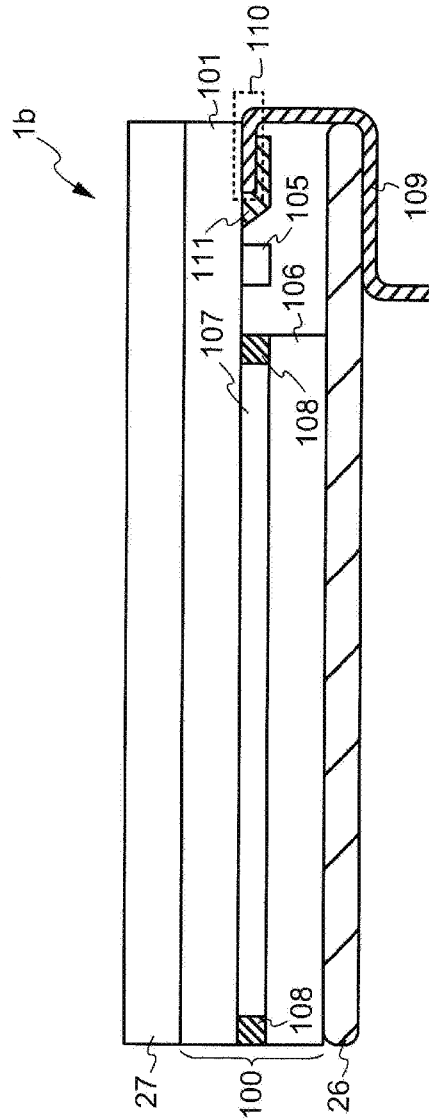

FIG.12

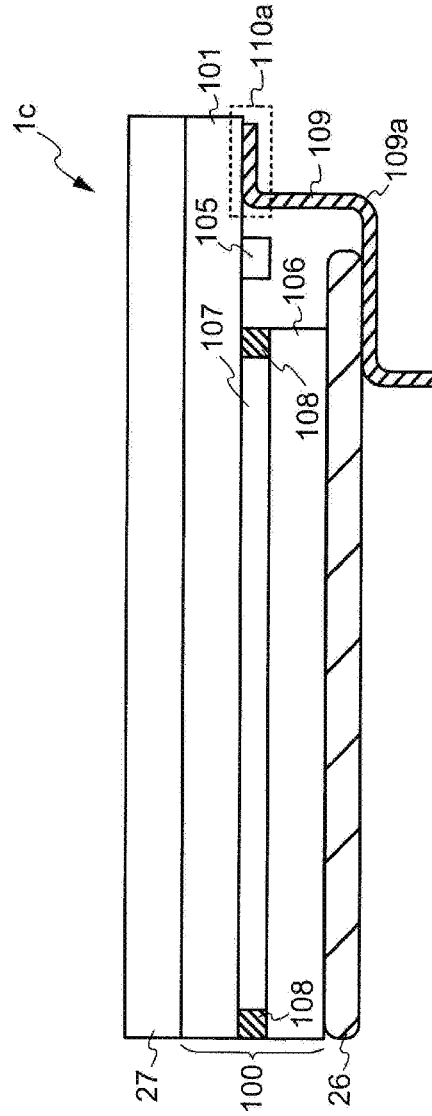

FIG. 13

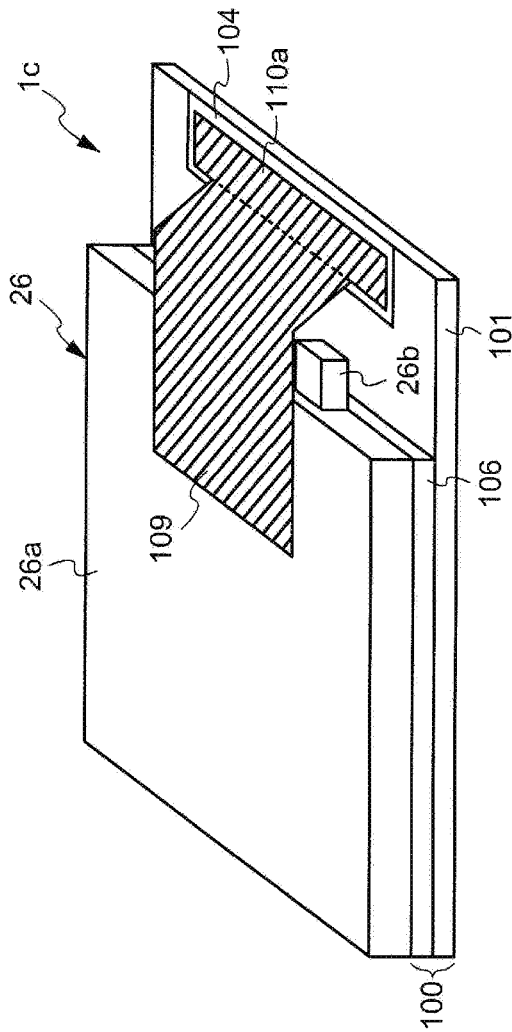

FIG. 14

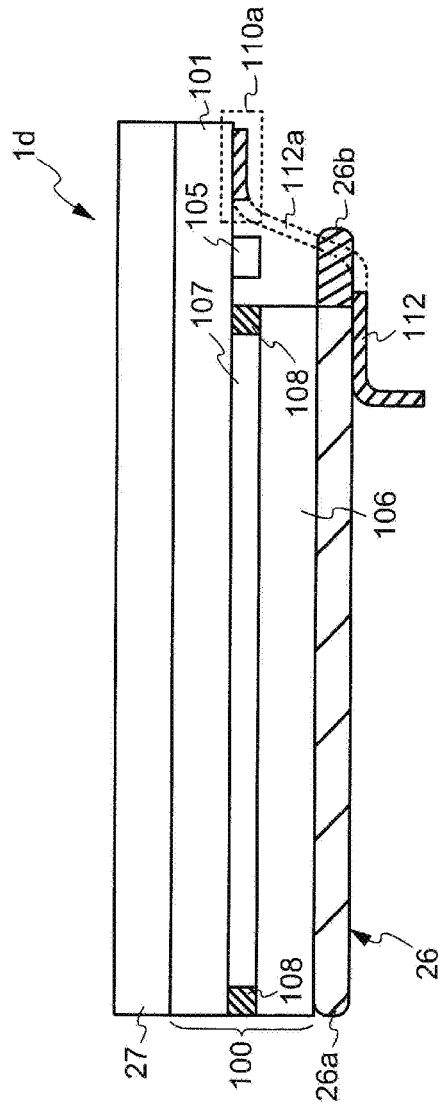
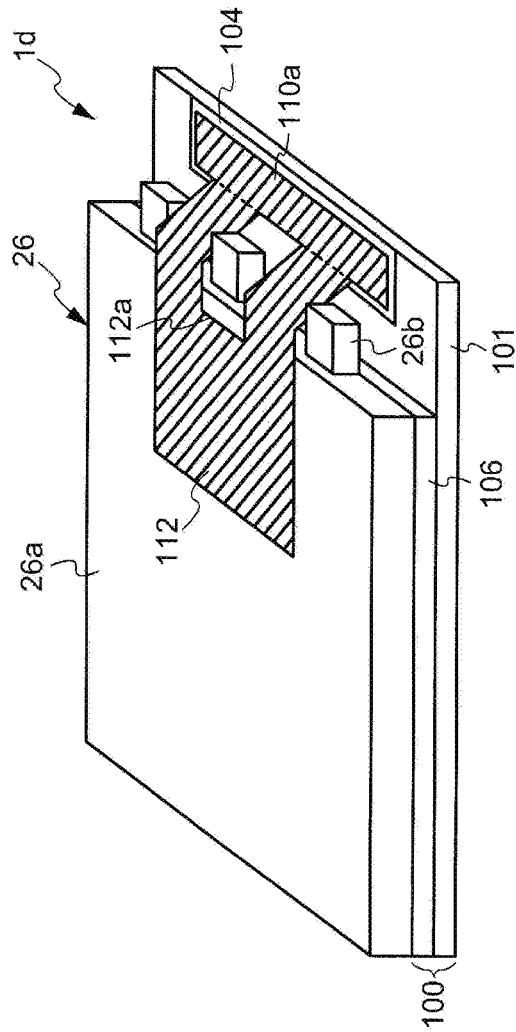

FIG. 15



1

IMAGE DISPLAY DEVICE**CROSS REFERENCE TO RELATED APPLICATIONS**

This application is based upon and claims the benefit of priority from the prior Japanese Patent Application No. 2016-054001, filed on Mar. 17, 2016 and the prior Japanese Patent Application No. 2016-166470, filed on Aug. 29, 2016, the entire contents of which are incorporated herein by reference.

FIELD

The present invention relates to an image display device including an electro-optical layer, and specifically to an image display device including a liquid crystal layer as the electro-optical layer.

BACKGROUND

Conventionally, a liquid crystal display (LCD) including a liquid crystal cell that includes a liquid crystal layer held between a pair of substrates is known. Such a liquid crystal display, which has features of being lightweight, thin and the like, is used as a display of a mobile information terminal such as a mobile phone, a tablet device or the like. Especially recently, the liquid crystal display is reduced in cost and thus is used in a wider range of fields including a wrist watch, an electric home appliance and the like, in addition to the mobile information terminal.

A main stream liquid crystal display is an active matrix type liquid crystal display including a switching element provided between one of a pair of substrates and a liquid crystal layer and performing on/off control on each of pixels by use of the switching element. This type of liquid crystal display allows light, introduced from a light source such as a backlight unit or the like, to be selectively transmitted by the on/off control on each pixel and provides an image by the transmitted light.

Especially a liquid crystal display capable of providing a color image has a structure in which light selectively transmitted through each pixel is divided into, for example, three primary colors of RGB by a color filter provided on an optical path and a desired color image is displayed by a combination of the three primary colors. A known example of the liquid crystal display is described in Japanese Laid-Open Patent Publication No. 2003-195288.

SUMMARY

An image display device in an embodiment according to the present invention includes a first substrate; a second substrate located to face the first substrate; an electro-optical layer between the first substrate and the second substrate; a plurality of pixel electrodes located between the electro-optical layer and the first substrate; a plurality of switching elements electrically connected with the plurality of pixel electrodes respectively; and a color filter included in a layer between the first substrate and the plurality of switching elements. A side of the first substrate opposite to a side thereof facing the electro-optical layer is an image display side.

An image display device in an embodiment according to the present invention includes a first substrate formed of a resin material; a second substrate located to face the first substrate; an electro-optical layer between the first substrate

2

and the second substrate; a plurality of pixel electrodes located between the electro-optical layer and the first substrate; a plurality of switching elements electrically connected with the plurality of pixel electrodes respectively; and a color filter. A side of the first substrate opposite to a side thereof facing the electro-optical layer is an image display side.

BRIEF EXPLANATION OF DRAWINGS

FIG. 1 shows a schematic structure of a liquid crystal module in embodiment 1;

FIG. 2 shows a cross-sectional structure of a pixel included in the liquid crystal module in embodiment 1;

FIG. 3 shows a schematic structure of an image display device in embodiment 1;

FIG. 4 shows a cross-sectional structure of a pixel included in a liquid crystal module in embodiment 2;

FIG. 5 shows a cross-sectional structure of a pixel included in a liquid crystal module in embodiment 3;

FIG. 6 shows a cross-sectional structure of a pixel included in a liquid crystal module in embodiment 4;

FIG. 7 shows a cross-sectional structure of a pixel included in a liquid crystal module in embodiment 5;

FIG. 8 shows a schematic structure of an image display device in embodiment 6;

FIG. 9 shows a cross-sectional structure of pixels included in a liquid crystal module in embodiment 7;

FIG. 10 shows a schematic structure of an image display device in embodiment 8;

FIG. 11 shows a schematic structure of the image display device in embodiment 8;

FIG. 12 shows a schematic structure of an image display device in embodiment 9;

FIG. 13 shows a schematic structure of the image display device in embodiment 9;

FIG. 14 shows a schematic structure of an image display device in embodiment 10; and

FIG. 15 shows a schematic structure of the image display device in embodiment 10.

DESCRIPTION OF EMBODIMENTS

The liquid crystal display described in Japanese Laid-Open Patent Publication No. 2003-195288 includes a pair of substrates, a liquid crystal layer, a TFT (thin film transistor) provided between one of the pair of substrates and the liquid crystal layer, and a color filter provided between the TFT and a pixel electrode. Such a structure increases the thickness of a region between the pixel electrode and the TFT, which requires a large contact hole to be formed in order to electrically connect the TFT and the pixel electrode to each other. As a result, the numerical aperture of the pixel may be undesirably decreased.

In the case of the liquid crystal display described in Japanese Laid-Open Patent Publication No. 2003-195288, there is no blocking member between a viewer of a screen thereof and the thin film transistor. Therefore, unnecessary light reflected by a metal line such as a signal line or the like included in the thin film transistor may undesirably decrease the visual recognizability.

One object of the present invention is to provide an image display device having high visual recognizability.

One object of the present invention is to provide an image display device easy to produce.

Hereinafter, embodiments of the present invention will be described with reference to the drawings. The present inven-

tion may be carried out in various forms without departing from the gist thereof, and is not to be construed as being limited to any of the following embodiments. In the drawings, components may be shown schematically regarding the width, thickness, shape and the like, instead of being shown in accordance with the actual sizes, for the sake of clearer illustration. The schematic drawings are merely exemplary and do not limit the interpretations of the present invention in any way. In the specification and the drawings, components that have substantially the same functions as those described before with reference to a previous drawing(s) bear the identical reference signs thereto, and detailed descriptions thereof may be omitted.

In this specification, the terms “up”, “down”, “outer”, “inner” and the like used with respect to the drawings each represent a positional relationship between a component that is a target of attention and another component. For example, in this specification, as seen in a side view, a direction from a liquid crystal layer toward a color filter is defined as “upward”, and an opposite direction is defined as “downward”. As seen in a plan view, a direction from the center of a display region toward an end of a substrate is defined as “outward”, and an opposite direction is defined as “inward”.

In this specification, in the case where the expression that “ α includes A, B or C”, “ α includes any one of A, B and C”, “ α includes one selected from the group consisting of A, B and C” or the like is provided, such an expression does not exclude a case where α includes any combination of A through C unless otherwise specified. Such an expression does not exclude, either, a case where α includes any other element.

In this specification, an “image display device” refers to a device displaying an image by use of an electro-optical layer. Therefore, the image display device encompasses a display module (also referred to as a “display panel”) including an electro-optical layer and also a display device including a combination of the display module and any other element (e.g., backlight unit, cover member, polarization member, etc.).

In each of the following embodiments, the “electro-optical layer” may encompass a liquid crystal layer, an electroluminescence (EL) layer, an electrochromic (EC) layer, and an electrophoretic layer unless any technological contradiction occurs. In each of the following embodiments, an image display device including a liquid crystal module that includes a liquid crystal layer will be described. However, the present invention is also applicable to an image display device including a display module including any of the above-described electro-optical layers.

Embodiment 1

First, a schematic structure of a liquid crystal module **100** included in an image display device **1** in embodiment 1 will be described. FIG. 1 shows a schematic structure of the liquid crystal module **100** in embodiment 1.

The liquid crystal module **100** includes an array substrate **101**, a display region **103** formed in the array substrate **101** and including a plurality of pixels **102**, a terminal region **104** supplying an external signal to the display region **103**, a driving integrated circuit **105** located between the display region **103** and the terminal region **104**, and a counter substrate **106** located to face the array substrate **101**. As described below, the image display device **1** may include a polarization member (e.g., polarization film) adjacent to each of the array substrate **101** and the counter substrate **106**.

The array substrate **101** has the plurality of pixels **102** provided therein, and the plurality of pixels **102** each include a switching element such as a thin film transistor or the like. The array substrate **101** is also referred to as an “active matrix substrate”. The pixels **102** are located in a matrix and form the display region **103** as a whole. Each of the pixels **102** includes a circuit using a thin film transistor acting as the switching element. The switching element is on/off-controlled to control the alignment of liquid crystal molecules in correspondence with each pixel **102**.

FIG. 1 shows the driving integrated circuit **105** provided in order to drive the thin film transistors included in the display region **103**. A gate driver circuit or a source driver circuit each including a thin film transistor may be provided around the display region **103**. In this case, the gate driver circuit or the source driver circuit is driven by a driving signal received from the driving integrated circuit **105**. The driving integrated circuit **105** may be an external IC chip or the like.

A liquid crystal layer **107** (see FIG. 2) is held between the array substrate **101** and the counter substrate **106**. An assembly of the array substrate **101**, the counter substrate **106** and the liquid crystal layer **107** may be referred to as a “liquid crystal cell”. The counter substrate **106** is bonded to the array substrate **101** by use of, for example, a sealing member containing a resin material.

FIG. 2 shows a cross-sectional structure of a pixel included in the liquid crystal module **100** in embodiment 1. The liquid crystal module **100** in this embodiment has a structure in which the liquid crystal layer **107** is held between the array substrate **101** and the counter substrate **106**. The liquid crystal module **100** in this embodiment performs image display on the side of the array substrate **101** with respect to the liquid crystal layer **107**. Therefore, unlike in a general liquid crystal module including a backlight unit provided on the side of the array substrate, a backlight unit is provided on the side of the counter substrate **106**.

In this embodiment, the array substrate **101** includes a glass substrate **11**, a color filter **12**, a light blocking layer **13**, an underlying layer **14**, a TFT (thin film transistor) **15**, a flattening layer **16**, a common electrode **17**, an insulating layer **18**, a pixel electrode **19**, and an alignment film **20**. The array substrate **101** may include any other element in addition to the above-described elements, needless to say.

The glass substrate **11** may be replaced with a substrate formed of any other light-transmissive material, for example, a resin substrate. In this specification, the term “resin substrate” refers to a flat plate-like member formed of a resin material. The “resin substrate” encompasses, for example, a molded sheet-like member formed of a resin material (resin sheet) and a film-like member formed of a resin material (resin film).

The color filter **12** is located in a light-transmissive region (region where light from a backlight unit is transmitted) of each pixel. The color filter **12** may be formed of, for example, a resin material containing a pigment. In accordance with the type of pigment, light of a part of a spectrum corresponding to each of colors such as R (red), G (green), B (blue) and W (white) is transmitted through the color filter **12**.

The light blocking layer **13** may be formed of, for example, a resin material containing a black pigment or carbon. As shown in FIG. 2, in this embodiment, the light blocking layer **13** is provided between the glass substrate **11** and the TFT **15**, so that the TFT **15** is not directly visually recognizable by a viewer of an image on the image display device **1**. Therefore, even in the case where the TFT **15** includes a gate electrode **15a** formed of a metal material,

external light reflected by the gate electrode **15a** is prevented from entering the eye of the viewer. The light blocking layer **13** is also referred to as a “black matrix”.

The light blocking layer **13** is a member provided for the purpose of blocking light, and therefore, may be a light-blocking metal film. However, in the case where the metal film is used as the light blocking layer **13**, capacitance coupling caused between the TFT **15** and the metal film may influence the operation of the image display device **1**. Therefore, in the structure of this embodiment, it is preferable that the light blocking layer **13** is formed of a resin material containing a black pigment.

In this embodiment, the color filter **12** and the light blocking layer **13** are both formed of a resin material. The resin material usable for the color filter **12** and the light blocking layer **13** is, for example, an acrylic resin, polyamide or the like. It is especially preferable to use an acrylic resin in consideration of the processing temperature and the retardation of the production process of the TFT **15** described below.

The underlying layer **14** is an insulating layer containing silicon such as silicon oxide, silicon nitride or the like. In this example, the underlying layer **14** is provided for the purpose of separating the color filter **12** and the light blocking layer **13** formed of a resin material from the TFT **15**. The underlying layer **14** may be referred to as an “overcoat” layer.

The TFT **15** acts as a switching element controlling the pixel **102** to be in an on state or an off state. In this embodiment, the TFT **15** is a so-called bottom gate-type TFT. Specifically, the TFT **15** in this embodiment includes the gate electrode **15a**, a gate insulating layer **15b**, an active layer **15c**, terminal electrodes **15d** and **15e**, and a protective layer **15f**.

In this embodiment, the active layer **15c** of the TFT **15** is formed of an oxide semiconductor. The oxide semiconductor usable for the active layer **15c** is, for example, a transparent amorphous oxide semiconductor (TAOS). The TAOS usable for the TFT **15** is, specifically, an oxide containing at least one of indium, gallium and zinc; for example, indium gallium zinc oxide (IGZO), indium gallium oxide (IGO), indium zinc oxide (IZO), zinc tin oxide (Zn-SnO), zinc oxide (ZnO) or the like.

In this embodiment, after the color filter **12** and the light blocking layer **13** are formed of a resin material, the TFT **15** is formed. Therefore, the heat resistance of the color filter **12** and the light blocking layer **13** needs to be considered. The oxide semiconductor may be formed into a film at a very low temperature of about 25° C. to about 100° C. Therefore, the TFT **15** may be formed even after the color filter **12** and the light blocking layer **13** are formed of a resin material.

The active layer **15c** may be formed of any semiconductor material that can be formed into a film at a temperature lower than, or equal to, the temperature at which the resin material is resistive; for example, may be formed of amorphous silicon.

The terminal electrodes **15d** and **15e** act as terminals that input a voltage to, or output a voltage from, the TFT **15**, and are usually referred to as a source electrode and a drain electrode. In this embodiment, the terminal electrodes **15d** and **15e** are formed of silicon containing n-type or p-type impurities. The functions of the terminal electrodes **15d** and **15e** are switched to each other in accordance with the direction in which the carriers move. Therefore, the terminal electrodes **15d** and **15e** may act as a source electrode or a drain electrode.

The protective layer **15f** is an insulating layer formed of silicon oxide, and has a role of protecting the TFT **15** against the flattening layer **16** formed of a resin material. Namely, the protective layer **15f** has a function of preventing the flattening layer **16** from contacting the active layer **15c**.

The flattening layer **16** is formed of a resin material and has a function of flattening convexed and concaved portions caused by the TFT **15**. In this embodiment, the flattening layer **16** is formed of an acrylic resin as the resin material, but may be formed of another resin material such as polyimide, polyamide or the like.

The common electrode **17** is formed of a transparent conductive film. The common electrode **17** is provided in order to form a lateral electric field (also referred to as a “fringe field”) between the common electrode **17** and the pixel electrode **19** adjacent thereto. The transparent conductive film usable for the common electrode **17** is formed of an inorganic compound such as ITO (indium tin oxide), ZnO (zinc oxide) or the like.

The insulating layer **18** is formed of silicon nitride, and is provided so as to cover the common electrode **17** and the flattening layer **16**. The insulating layer **18** electrically insulates the common electrode **17** and the pixel electrode **19** from each other, and also acts as an insulating element for a storage capacitance formed by the common electrode **17** and the pixel electrode **19**.

The pixel electrode **19** is formed of a transparent conductive film, and as described above, forms a lateral electric field between the pixel electrode **19** and the common electrode **17**. The transparent conductive film usable for the pixel electrode **19** is formed of an inorganic compound such as ITO (indium tin oxide), ZnO (zinc oxide) or the like. The pixel electrode **19** is electrically connected with the TFT **15** via a contact hole formed in the flattening layer **16**.

The above-described structure allows the potential of the pixel electrode **19** to be controlled via the TFT **15**, and thus a desired voltage is allowed to be applied between the common electrode **17** and the pixel electrode **19**. In this manner, a predetermined electric field is formed between the common electrode **17** and the pixel electrode **19**, and the electric field controls the alignment of the liquid crystal molecules in the liquid crystal layer **107**. The alignment film **20** may be a known alignment film or may be omitted.

The liquid crystal module **100** in this embodiment includes the counter substrate **106** provided to face the array substrate **101** having the above-described structure. In this embodiment, the counter substrate **106** includes a glass substrate **21** and an alignment film **22**. The glass substrate **21** may be replaced with a substrate formed of a light-transmissive material, like the glass substrate **11**. The alignment film **22** may be a known alignment film or may be omitted.

As described above, in the liquid crystal module **100** in this embodiment, the array substrate **101** includes the color filter **12**, the light blocking layer **13**, the TFT **15** and the pixel electrode **19**. Therefore, the counter substrate **106** in this embodiment does not include any element other than the glass substrate **21** and the alignment film **22**. Namely, the counter substrate **106** includes, other than the glass substrate **21**, only a so-called flat, uniform film (i.e., a non-patterned film, or a film having a uniform thickness in at least a region overlapping the display region). The counter substrate **106** in the liquid crystal module **100** in this embodiment does not include any element that needs to be aligned in terms of the position (e.g., a color filter, a light blocking layer, or an overcoat layer covering the color filter or the light blocking layer). Therefore, it is not necessary to perform a precise positional alignment for bonding the array substrate **101** and

the counter substrate **106** to each other, which simplifies the production process of the liquid crystal module **100**. The alignment film **20** and the alignment film **22** in the substrates **101** and **106** need to be positionally aligned, but the positional alignment does not need to be precise. In the liquid crystal module **100** in this embodiment, the light blocking layer **13** protecting the TFT **15** against light also acts to demarcate the color filters **12** of a plurality of colors. Therefore, it is not necessary to provide another light blocking layer demarcating the color filters **12** or an overcoat layer covering such a light blocking layer.

The alignment film **22** in the counter substrate **106** is a flat layer. Therefore, the liquid crystal molecules may be aligned by rubbing alignment as well as by optical alignment on the side of the counter substrate **106**. By contrast, on the side of the array substrate **101** including the alignment **20** having concaved and convexed portions, it is preferable to align the liquid crystal molecules by optical alignment.

In this embodiment, the counter substrate **106** includes only the glass substrate **21** and the alignment film **22**. Alternatively, the counter substrate **106** may include any other element. For example, a further layer such as an overcoat layer or the like may be provided between the glass substrate **21** and the alignment film **22**. However, it is desirable that a stack of the further layer such as an overcoat layer or the like and the alignment film **22** is flat in at least a region overlapping the display region **103** in order to make the above-described positional alignment unnecessary. Namely, it is desirable that a flat layer overlapping the pixel electrode **19** as seen in a plan view is provided on a surface of the glass substrate **21** facing the liquid crystal layer **107**. With such a structure, it is not necessary to perform the precise positional alignment for bonding the array substrate **101** and the counter substrate **106** to each other.

As shown in FIG. 2, in this embodiment, the side of the glass substrate **11** opposite to the side facing the liquid crystal layer **107** is the image display side (i.e., the viewer side) (i.e., the side of the glass substrate **11** opposite to the side on which the color filter **12** and the light blocking layer **13** are provided is the image display side). Therefore, the light blocking layer **13** is provided between the glass substrate **11** and the TFT **15**, and thus unnecessary light reflected by a metal line (e.g., gate electrode **15a**) included in the TFT **15** is prevented from entering the eye of the viewer located at the image display side. Conventionally, a light blocking layer is always included in a counter substrate. In this embodiment, the light blocking layer does not need to be included in the counter substrate **106**.

The liquid crystal module **100** in this embodiment includes a great number of pixel electrodes **19** in at least the display region **103**. Therefore, an inconvenience that external electrostatic charges adversely influence the liquid crystal layer **107** is suppressed. In the liquid crystal module **100** of the lateral electric field type, the common electrode **17** is provided over at least the entirety of the display region **103**. Therefore, the external electrostatic charges are further suppressed from adversely influencing the liquid crystal layer **107**. Namely, an inconvenience that when an electric field is applied to the liquid crystal layer **107**, the external electrostatic charges disturb the electric field and thus disturb the alignment of the liquid crystal molecules is suppressed.

Now, with reference to FIG. 3, the image display device **1** including the liquid crystal module **100** will be described. FIG. 3 shows a schematic structure of the image display device **1** in embodiment 1.

The liquid crystal module **100** has a structure in which the array substrate **101** and the counter substrate **106** described above with reference to FIG. 2 are bonded together with a sealing member **108**, and the liquid crystal layer **107** is held in a space enclosed by the sealing member **108**. To an end of a surface of the array substrate **101** facing the liquid crystal layer **107** (specifically, to the terminal region **104** shown in FIG. 1), a flexible printed circuit (FPC) **109** transmitting a signal to, and receiving a signal from, an external circuit is connected. As shown in FIG. 3, the image display device **1** in this embodiment includes a backlight unit **26** on the side of the counter substrate **106** of the liquid crystal module **100**, and also includes a cover member **27** on the side of the array substrate **101**. Although not shown, a polarization member (e.g., polarization film) is provided between the counter substrate **106** and the backlight unit **26**, and also between the array substrate **101** and the cover member **27**.

The backlight unit **26** is provided on a side of the counter substrate **106** (specifically, the glass substrate **21** shown in FIG. 2) opposite to the side facing the liquid crystal layer **107** (i.e., the backlight unit **26** is provided on the “backlight side” in FIG. 2). Therefore, light emitted from the backlight unit **26** is transmitted through the counter substrate **106**, the polarization member (not shown), the liquid crystal layer **107** and the array substrate **101** in this order.

The cover member **27** is provided on a side of the array substrate **101** (specifically, the glass substrate **11** shown in FIG. 2) opposite to the side facing the liquid crystal layer **107** (i.e., the cover member **27** is provided on the “image display side” in FIG. 2). Therefore, the viewer visually recognizes, via the cover member **27**, an image displayed by the liquid crystal module **100**.

The cover member **27** may be formed of a glass material or a plastic material. It is desirable to use a cover member formed of a glass material (also referred to as a “cover glass”) in order to protect the liquid crystal module **100**.

As described above, unlike in the conventional structure, the image display device **1** in this embodiment includes the backlight unit **26** on the side of the counter substrate **106** of the liquid crystal module **100**, not on the side of the array substrate **101**.

In this embodiment, the cover member **27** is provided for the purpose of protecting the liquid crystal module **100**. Therefore, the cover member **27** is provided on the side of the array substrate **101**, unlike in the conventional structure. In the case where a touch panel is mounted, the cover member **27** may be used as a member for forming an electrode of a sensor for the touch panel.

Embodiment 2

With reference to FIG. 4, a liquid crystal module **100a** in embodiment 2 will be described. Unlike the liquid crystal module **100** in embodiment 1, the liquid crystal module **100a** in embodiment 2 includes resin substrates **31** and **32** as support substrates instead of the glass substrates **11** and **21**. In this embodiment, the differences from embodiment 1 will be mainly described, and elements same as those of the liquid crystal module **100** in embodiment 1 bear the same reference signs thereto and descriptions thereof may be omitted. In this embodiment, the color filter **12** may be provided in a counter substrate **106a**.

FIG. 4 shows a cross-sectional structure of a pixel included in the liquid crystal module **100a** in embodiment 2. The liquid crystal module **100a** shown in FIG. 4 includes the resin substrate **31** as the support substrate for an array

substrate **101a** and includes an assembly of the resin substrate **32** and a resin film **33** as the support substrate for the counter substrate **106a**. In this embodiment, the resin substrates **31** and **32** are polyimide substrates.

The liquid crystal module **100a** in this embodiment includes a great number of pixel electrodes **19** in at least a region overlapping the display region **103**, and therefore, suppresses an inconvenience that the external electrostatic charges adversely influence the liquid crystal layer **107**. In the liquid crystal module **100a** of the lateral electric field type, the common electrode **17** is provided over the entirety of the display region **103**. Therefore, the external electrostatic charges are further suppressed from adversely influencing the liquid crystal layer **107**. Namely, an inconvenience that when an electric field is applied to the liquid crystal layer **107**, the external electrostatic charges disturb the electric field and thus disturb the alignment of the liquid crystal molecules is suppressed.

In order to protect a liquid crystal layer against external electrostatic charges, a technology of providing a transparent conductive film between the liquid crystal module and a cover member is in wide use for liquid crystal displays. In this embodiment, however, the support substrate of the array substrate **101a** is the resin substrate **31**. Therefore, in the case where, for example, a transparent conductive film is formed by a method such as sputtering, photolithography or the like, the resin material may be deteriorated by the load applied at the time of the formation of the transparent conductive film. In this embodiment, as described above, the array substrate **101a** including the pixel electrode **19** and the common electrode **17** is located on the image display side, and these electrodes protect the liquid crystal layer **107** against the electrostatic charges. In other words, it is not necessary to provide a transparent conductive film on the image display side of the array substrate **101a**.

In the case where the resin substrates **31** and **32** are polyimide substrates, it is desirable that the resin substrates **31** and **32** are as thin as possible because a large retardation is caused to the polyimide substrates. However, the polyimide substrates become weaker as becoming thinner. Therefore, it is preferable to provide some reinforcement to the resin substrates **31** and **32**.

In this embodiment, the counter substrate **106a** includes the resin film **33** as a reinforcing member provided between the resin substrate **32** and the liquid crystal layer **107**. Thus, the retardation of the resin substrate **32** formed of polyimide is alleviated while the counter substrate **106a** is reinforced by the resin film **33**. In this case, the resin film **33** is formed of a resin material other than polyimide. Examples of the resin material usable for the resin film **33** include polyethylene, polypropylene, acrylic resin, methacrylic resin, epoxy, urethane, polyaramide, polystyrene, polyarylate and the like. Among these materials, polyaramide, polystyrene and polyarylate are preferable.

In the liquid crystal module **100a** in this embodiment, the color filter **12** and the light blocking layer **103** formed of a resin material are located in contact with the resin substrate **31**. The color filter **12** and the light blocking layer **103** act as reinforcing members that reinforce the array substrate **101a**. Therefore, the array substrate **101a** does not need to include any member corresponding to the resin film **33**, unlike the counter substrate **106a**. In this case also, it is preferable that the color filter **12** and the light blocking layer **103** are formed of a resin material other than polyimide.

In this embodiment, the resin substrates **31** and **32** are formed of polyimide. The material of the resin substrates **31** and **32** is not limited to polyimide. For example, the resin

substrates **31** and **32** may be formed of PET or a fiber-reinforced plastic (FRP) material, instead of polyimide.

Use of the resin substrates as the support substrates as described above allows the thickness of each of the array substrate **101a** and the counter substrate **106a** to be suppressed to 30 μm or less (typically, 5 to 20 μm). In this embodiment, the resin substrates **31** and **32** used as the support substrates are very thin, and therefore, the array substrate **101a** and the counter substrate **106a** may be treated as being flexible.

Embodiment 3

With reference to FIG. 5, a liquid crystal module **100b** in embodiment 3 will be described. Unlike the liquid crystal module **100** in embodiment 1, the liquid crystal module **100b** in embodiment 3 includes resin substrates **36** and **37** having different properties from each other as the support substrates on the side of an array substrate **101b** and on the side of a counter substrate **106b**, instead of the glass substrates **11** and **21**. In this embodiment, the differences from embodiment 1 will be mainly described, and elements same as those of the liquid crystal module **100** in embodiment 1 bear the same reference signs thereto and descriptions thereof may be omitted.

FIG. 5 shows a schematic structure of a pixel included in the liquid crystal module **100b** in embodiment 3. The liquid crystal module **100b** in this embodiment may include the resin substrate **36** formed of polyimide as the support substrate included in the array substrate **101b**. The liquid crystal module **100b** may include the resin substrate **37** formed of, for example, polystyrene as the support substrate included in the counter substrate **106b**. Namely, the support substrates in the array substrate **101b** and the counter substrate **106b** may be formed of different resin materials from each other.

Herein, the term "properties" refer to physical properties of a substance. Specifically, in this embodiment, the glass transition temperature (T_g), the coefficient of linear thermal expansion (CTE), the UV transmittance, the thickness-direction retardation (T_{th}) and the in-plane retardation (R_o) will be mainly described. Any other physical property may be considered, or one or more of the above-listed physical properties may not be considered.

Like in embodiment 1, in the liquid crystal module **100b** in this embodiment, the array substrate **101b** includes the color filter **12**, the light blocking layer **13**, the TFT **15** and the pixel electrode **19**. Therefore, the counter substrate **106b** does not include any element other than the glass substrate **21** and the alignment film **22**. This simplifies the production process of the counter substrate **106b**. Therefore, in the liquid crystal module **100b** in this embodiment, the material of the resin substrate **37** may be selected with a higher degree of freedom than the material of the resin substrate **36** in the array substrate **101b**. This allows the resin substrate **37** in the counter substrate **106b** to have different properties from those of the resin substrate **36** in the array substrate **101b**.

It is preferable that the thickness-direction retardation, which significantly influences the transmittance of the substrate, is as low as possible. Therefore, it is desirable that the material of the resin substrate **37** has a lower thickness-direction retardation than that of the material of the resin substrate **36**. In the case where the resin substrate **37** is formed of a material having a low thickness-direction retardation, the liquid crystal display may be reduced in size because, for example, a retardation compensation member

11

(e.g., retardation compensation film) may be omitted. Since a material having a low thickness-direction retardation is usable, the resin substrate **37** may be made thicker than the resin substrate **36**, which reinforces the counter substrate **106b**.

In the liquid crystal module **100b** in this embodiment, the counter substrate **106b** may be a sheet-like member. In general, a resin substrate is formed as follows. A resin layer of polyimide or the like is formed on a support plate, and the support plate is peeled off from the resin layer, so that the left resin layer acts as the resin substrate. Therefore, a glass plate is needed as the support plate, and the step of peeling off the glass plate from the resin layer is needed. By contrast, in this embodiment, the material of the resin substrate **37** may be selected with a high degree of freedom. This allows a resin sheet of polyaramide, polystyrene, polyarylate or the like to be used as the counter substrate. The support plate or the step of peeling off is not needed. The resin sheet is already molded and is not much thermally expanded or shrunk. Thus, use of a resin sheet allows the material of the resin substrate **37** to be selected from a wide range of materials in consideration of the thickness and the properties.

Embodiment 4

With reference to FIG. **6**, a liquid crystal module **100c** in embodiment 4 will be described. Unlike the liquid crystal module **100** in embodiment 1, the liquid crystal module **100c** in embodiment 4 further includes a light blocking layer **41** provided between the TFT **15** and the backlight unit **26** (FIG. **3**). In this embodiment, the differences from embodiment 1 will be mainly described, and elements same as those of the liquid crystal module **100** in embodiment 1 bear the same reference signs thereto and descriptions thereof may be omitted.

FIG. **6** shows a cross-sectional structure of a pixel included in the liquid crystal module **100c** in embodiment 4. The liquid crystal module **100c** in this embodiment includes, in addition to the light blocking layer **13**, the light blocking layer **41** provided between the TFT **15** and the liquid crystal layer **107** (specifically, between the protective layer **15f** and the flattening layer **16**). As seen in a plan view, the light blocking layer **41** is located at a position overlapping the active layer **15c**. The light blocking layer **41** may be formed of a metal material or may be formed of a resin material containing a black pigment or carbon.

In the liquid crystal module **100c** in this embodiment, light emitted from the backlight unit **26** (see FIG. **3**) is blocked by the light blocking layer **41** and thus does not reach the active layer **15c**. Therefore, a leak current is prevented from being generated by light excitation in the active layer **15c**.

In this embodiment, the light blocking layer **41** is provided between the protective layer **15f** and the flattening layer **16**. The light blocking layer **41** is not limited to being provided at this position. The light blocking layer **41** merely needs to be provided between the TFT **15** and the backlight unit **26**. For example, the light blocking layer **41** may be provided in a part of the counter substrate **106** although not shown. However, it is preferable that the light blocking layer **41** is provided in a part of an array substrate **101c** because as the distance between the light blocking layer **41** and the active layer **15c** is shorter, the light is blocked more effectively.

Embodiment 5

With reference to FIG. **7**, a liquid crystal module **100d** in embodiment 5 will be described. Unlike the liquid crystal

12

module **100** in embodiment 1, the liquid crystal module **100d** in embodiment 5 includes a reflective layer **46** provided over a plurality of pixels in a counter substrate **106d**, so that the liquid crystal module **100d** is of a reflection type. In this embodiment, the differences from embodiment 1 will be mainly described, and elements same as those of the liquid crystal module **100** in embodiment 1 bear the same reference signs thereto and descriptions thereof may be omitted.

FIG. **7** shows a cross-sectional structure of a pixel included in the liquid crystal module **100d** in embodiment 5. The liquid crystal module **100d** in this embodiment includes the reflective layer **46** provided in a part of the counter substrate **106d**, more specifically, between the glass substrate **21** and the liquid crystal layer **107**. The reflective layer **46** is provided in order to reflect external light incident thereon from the image display side, and may be formed of a metal material. The metal material usable for the reflective layer **46** is, for example, aluminum or silver having a high reflectance.

In the liquid crystal module **100d** in this embodiment, a common potential is applied to the reflective layer **46** to form a vertical electric field between the pixel electrode **19** and the reflective layer **46**. The vertical electric field controls the alignment of the liquid crystal molecules in the liquid crystal layer **107**. Therefore, an array substrate **101d** in this embodiment may not need to include the common electrode **17** or the insulating layer **18** described in embodiment 1. In embodiment 5, a line transmitting the common potential to the array substrate **101d** may be provided, and the line and the reflective layer **46** may be electrically connected with each other outside the display region **103**.

In this embodiment, the control mode on the liquid crystal layer **107** is a VA mode. The control mode is not limited to the VA mode, and may be a TN mode or an ECB mode. Alternatively, the control mode may be an IPS mode or an FFS mode, which is a lateral field mode, in the case where the array substrate **101d** includes the common electrode **17**. In this case, it is not necessary to apply the common potential to the reflective layer **46**.

In the liquid crystal module **100d** in this embodiment, the reflective layer **46** is provided in a part of the counter substrate **106d** (as seen in a plan view, in at least a region overlapping the display region **103**). Therefore, external light incident from the image display side is reflected upward in a wide range. In a conventional reflective type liquid crystal module, each of pixel electrodes acts as a reflective layer. Therefore, the area size of reflection is small. By contrast, in this embodiment, the external light is reflected by the reflective layer **46** having an area size corresponding to at least the entirety of the display region **103**. Therefore, the liquid crystal module **100d** has an improved reflection efficiency.

Embodiment 6

With reference to FIG. **8**, an image display device **1a** in embodiment 6 will be described. Unlike the image display device **1** in embodiment 1, the image display device **1a** in embodiment 6 includes a pair of signal receiver/transmitter **51** and **53** receiving and transmitting a video signal, and video signals are received and transmitted between the array substrate **101** and an external circuit **52**. In this embodiment, the differences from embodiment 1 will be mainly described, and elements same as those of the image display device **1** in embodiment 1 bear the same reference signs thereto and descriptions thereof may be omitted.

FIG. 8 shows a schematic structure of the image display device **1a** in embodiment 6. The image display device **1a** in this embodiment includes the pair of signal receiver/transmitter **51** and **53** receiving and transmitting a video signal. The pair of signal receiver/transmitter **51** and **53** are, for example, a signal receiver **51** located in the array substrate **101** and a signal transmitter **53** located in the external circuit **52**. It should be noted that the signal transmitter **51** may have a signal transmission function and the signal transmitter **53** may have a signal receiving function so as to realize a bidirectional communication.

In the image display device **1a** in this embodiment, the signal receiver **51** is located on a side of the array substrate **101** (specifically, the glass substrate **11** shown in FIG. 2) facing the liquid crystal layer **107**, and the signal transmitter **53** is provided in the external circuit **52** located on a side of the counter substrate **106** (specifically, the glass substrate **21** shown in FIG. 2) opposite to the side facing the liquid crystal layer **107**. The signal receiver **51** and the signal transmitter **53** face each other.

The external circuit **52** may be an integrated circuit generating a video signal, or an integrated circuit decoding and storing a video signal received from a server or the like and outputting the stored video signal. The external circuit **52** may be any type of integrated circuit capable of outputting a video signal from the signal transmitter **53** to the signal receiver **51**.

The signal receiver **51** and the signal transmitter **53** may use any communication system capable of communicating a video signal. The signal receiver **51** and the signal transmitter **53** may use, for example, a short range wireless communication technology such as NFC (Near Field Communication), Bluetooth (registered trademark) or the like, or an infrared communication technology.

In the case of a conventional image display device allowing an image to be observed from the counter substrate side, an array substrate is located between a signal transmitter and a signal receiver. Therefore, the distance between the signal transmitter and the signal receiver is long and thus a communication error is easy to occur. Also in such a conventional image display device, the array substrate acts as a blocking member against infrared communication. By contrast, in the image display device **1a** in this embodiment, the signal receiver **51** and the signal transmitter **53** face each other, and thus the above-described problems do not occur.

As described above, in this embodiment, in the image display device receiving a video signal from an external circuit and displaying an image, the transmission and receiving of the video signal are performed efficiently. Such an image display device has a high communication quality.

Embodiment 7

With reference to FIG. 9, a liquid crystal module **100e** in embodiment 7 will be described. Unlike the liquid crystal module **100** in embodiment 1, the liquid crystal module **100e** in embodiment 7 includes a polymer-containing resin structural body **56** in a liquid crystal layer **107e**. In this embodiment, the differences from embodiment 1 will be mainly described, and elements same as those of the liquid crystal module **100** in embodiment 1 bear the same reference signs thereto and descriptions thereof may be omitted.

FIG. 9 shows a cross-sectional structure of pixels included in the liquid crystal module **100e** in embodiment 7. The liquid crystal module **100e** in this embodiment includes the resin structural body **56** provided in the liquid crystal layer **107e**. Specifically, as seen in a plan view, the resin

structural body **56** is provided in a region that is between pixels adjacent to each other (specifically, between pixel electrodes adjacent to each other) and overlaps the light blocking layer **13**.

The resin structural body **56** is a structural body obtained as a result of polymerization of a monomer (i.e., is a polymer), and is also referred to as a “polymer wall”. A preferable monomer usable for the resin structural body **56** is a monomer having a high solubility in a liquid crystal material and thus having a molecular framework similar to that of the liquid crystal molecules such as, for example, a phenyl group, a cyclohexane group or the like. Specific examples of the material usable for the resin structural body **56** include polyethylene, polypropylene, polyolefin, acrylic resin, methacrylic resin, epoxy, urethane, polystyrene, poly(vinyl alcohol), fluorine-based resin, and a copolymer thereof.

A method for forming the resin structural body **56** may be the following method described in, for example, Japanese Laid-Open Patent Publication No. 2007-65270. A monomer is dispersed in advance in the liquid crystal layer **107e**. The liquid crystal layer **107e** is irradiated with ultraviolet light (typically, light having a central wavelength of 365 nm) directed, through the counter substrate **106**, between the pixels to locally polymerize the monomer. Thus, the resin structural body **56** is formed. In this case, the resin structural body **56** may be considered as a polymer of the monomer dispersed in advance in the liquid crystal layer **107e**. Alternatively, the resin structural body **56** may be considered as a three-dimensional crosslinked body of such a polymer.

The resin structural body **56** formed as a result of polymerization of the monomer dispersed in the liquid crystal layer **107e** has a feature of being bonded to both of the array substrate **101** and the counter substrate **106**. A column-like resinous spacer generally used widely is integrated with a flattening layer formed of an organic material. Such a spacer is usable to adjust the interval in the thickness direction of the liquid crystal module, but is not usable to suppress the offset in a direction parallel to the surfaces of the array substrate and the counter substrate. In the case where such a spacer is used, the alignment film may be shaved as a result of the offset in the direction parallel to the surfaces of the substrates, which may decline the quality. By contrast, the resin structural body **56** in this embodiment is bonded to both of the pair of substrate **101** and **106**, and thus overcomes for the above-described disadvantage of the column-like spacer.

The resin structural body **56** is formed by polymerization of the monomer dispersed in the liquid crystal layer **107e**. As a result, after the optical energy is provided (namely, after the resin structural body **56** is formed), the monomer not used to form the resin structural body **56** may remain in the liquid crystal layer **107e**.

As described above, the resin structural body **56** may be located in a desired region, specifically, in a region in the liquid crystal layer **107e** that is between the pixels adjacent to each other (specifically, between the pixel electrodes adjacent to each other) and overlaps the light blocking layer **13** as seen in a plan view by use of this embodiment and the technology described in Japanese Laid-Open Patent Publication No. 2007-65270.

The structure of the liquid crystal module **100e** in this embodiment is preferable to form the resin structural body **56** by use of the polymer formation technology described in Japanese Laid-Open Patent Publication No. 2007-65270. For forming the resin structural body **56**, the liquid crystal layer **107e** is irradiated with ultraviolet light directed

15

through the counter substrate **106** using a metal mask having an opening in a region corresponding to a region between the pixels. Thus, the monomer, which is of an ultraviolet-curable type, in the liquid crystal layer **107e** is polymerized to form the resin structural body **56**. A liquid crystal module of a conventional structure includes a light blocking layer in a counter substrate so as to block light directed toward a region between the pixels as seen in a plan view. Therefore, the ultraviolet light, which is directed through the counter substrate, is blocked by the light blocking layer and thus does not efficiently irradiate a region of the liquid crystal layer between the pixels.

By contrast, the liquid crystal module **100e** in this embodiment does not need to include a light blocking layer in the counter substrate **106**. Therefore, the ultraviolet light is merely directed through the counter substrate **106** by use of a metal mask, so that a region of the liquid crystal layer **107e** between the pixels is irradiated with the ultraviolet light efficiently to form the resin structural body **56**. The resin structural body **56** may be formed at any position in accordance with the position of the opening in the metal mask, as well as in the region between the pixels.

The technology described in embodiment 3 may be used to form, as the support substrate included in the counter substrate **106**, a resin substrate of a resin material having a high UV transmittance such as polystyrene or the like. In this case, the efficiency of ultraviolet light irradiation is further improved, which increases the production yield.

Embodiment 8

With reference to FIG. **10**, an image display device **1b** in embodiment 8 will be described. Unlike in the image display device **1** in embodiment 1, in the image display device **1b** in embodiment 8, the flexible printed circuit **109** is foldable and thus the entirety of the image display device **1b** is reduced in size. In this embodiment, the differences from embodiment 1 will be mainly described, and elements same as those of the image display device **1** in embodiment 1 bear the same reference signs thereto and descriptions thereof may be omitted.

FIG. **10** shows a schematic structure of the image display device **1b** in embodiment 8. In this embodiment, the flexible printed circuit **109** is located on a side of the array substrate **101** facing the liquid crystal layer **107**, and the backlight unit **26** is located on a side of the counter substrate **106** opposite to the side facing the liquid crystal layer **107**. The flexible printed circuit **109** is folded to face a side of the backlight unit **26** opposite to the side facing the counter substrate **106**.

Namely, in the case where the liquid crystal module **100** in embodiment 1 is used in the image display device **1b**, as shown in FIG. **10**, the flexible printed circuit **109** is foldable so as to overlap the backlight unit **26** as seen in a plan view. This is unique to the image display device **1b** in this embodiment, which allows an image to be observed from the side of the array substrate **101**.

As described above, a majority part of the flexible printed circuit **109** faces a rear surface of the backlight unit **26** (side of the backlight unit **26** opposite to the side facing the counter substrate **106**) as seen from the array substrate **101**. Therefore, the entirety of the image display device **1b** is reduced in size with no influence on the image display.

With the structure shown in FIG. **10**, a load may be undesirably applied to a connection portion **110** of the terminal region **104** in the array substrate **101** and the flexible printed circuit **109** in a direction in which the flexible printed circuit **109** is peeled off.

16

Thus, as shown in FIG. **11**, a reinforcing member **111** formed of a resin material such as epoxy resin or the like may be used to reinforce the connection portion **110**. In this case, the connection strength of the connection portion **110** of the terminal region **104** and the flexible printed circuit **109** is increased, and thus generation frequency of connection faults at the connection portion **110** is decreased.

Embodiment 9

With reference to FIG. **12**, an image display device **1c** in embodiment 9 will be described. In the image display device **1c** in embodiment 9, the flexible printed circuit **109** is attached to the array substrate **101** in a direction opposite to that in the image display device **1b** in embodiment 8. In this embodiment, the differences from embodiment 1b will be mainly described, and elements same as those of the image display device **1b** in embodiment 8 bear the same reference signs thereto and descriptions thereof may be omitted.

FIG. **12** shows a schematic structure of the image display device **1c** in embodiment 9. FIG. **13** also shows a schematic structure of the image display device **1c** in embodiment 9. In this embodiment, an end of the flexible printed circuit **109** is directed outward with respect to the liquid crystal layer **107** (direction away from the liquid crystal layer **107**) at a connection portion **110a** of the flexible printed circuit **109** and the terminal region **104**. In other words, a folded portion **109a** of the flexible printed circuit **109** overlaps the array substrate **101** as seen in a plan view. Therefore, in this embodiment, the entirety of the flexible printed circuit **109** overlaps the array substrate **101** as seen in a plan view.

In this case, as shown in FIG. **12**, among surfaces of the flexible printed circuit **109**, the surface facing the array substrate **101** in the connection portion **110a** and the surface facing the backlight unit **26** in a region overlapping the backlight unit **26** are the same surface. This is also different from the image display device **1b** in embodiment 8.

With such a structure, a large load is not applied to the connection portion **110a** in a direction in which the flexible printed circuit **109** is peeled off when the flexible printed circuit **109** is folded. Therefore, the connection portion **110a** has a sufficient strength with no need to provide the reinforcing member **111** described above with reference to FIG. **11**.

Embodiment 10

With reference to FIG. **14**, an image display device **1d** in embodiment 10 will be described. Unlike the image display device **1c** in embodiment 9, the image display device **1d** in this embodiment includes a flexible printed circuit **112** having an opening **112a**. In this embodiment, the differences from embodiment 1c will be mainly described, and elements same as those of the image display device **1c** in embodiment 9 bear the same reference signs thereto and descriptions thereof may be omitted.

FIG. **14** shows a schematic structure of the image display device **1d** in embodiment 10. FIG. **15** also shows a schematic structure of the image display device **1d** in embodiment 10. In this embodiment, the backlight unit **26** includes a light guide plate **26a** and a light source **26b** located to the side of the light guide plate **26a**. The flexible printed circuit **112** has the opening **112a** at a position where, when the flexible printed circuit **112** is folded so as to overlap the backlight unit **26**, the flexible printed circuit **112** and the light source **26** would contact each other. Namely, the flexible printed circuit **112** included in the image display

17

device **1d** in this embodiment has the opening **112a**, and the light source **26b** is located in the opening **112a**.

In other words, the light source **26b** is located to the side of the light guide plate **26a** so as to overlap the array substrate **101** as seen in a plan view, and the flexible printed circuit **112** is formed to have the opening **112a** such that the flexible printed circuit **112** does not overlap the light source **26b**. Therefore, even if the backlight unit **26** and the flexible printed circuit **112** are close to each other, the light source **26b** and the flexible printed circuit **112** are prevented from contacting each other.

As described above, the image display device **1d** in this embodiment includes the light source **26b** overlapping the array substrate **101** and allows the flexible printed circuit **112** to be close the back light unit **26** while preventing the flexible printed circuit **112** from contacting the light source **26b**. As a result, the image display device **1d** is further reduced in size.

The devices described above in embodiments according to the present invention may have an element added thereto, or deleted therefrom, or may be changed in design optionally by a person of ordinary skill in the art. The methods described above in embodiments according to the present invention may have a step added thereto, or deleted therefrom, or may be changed in a condition optionally by a person of ordinary skill in the art. Such devices and methods are encompassed in the scope of the present invention as long as including the gist of the present invention.

Even functions and effects that are different from those provided by the above-described embodiments but are obvious from the description of this specification or are easily expectable by a person of ordinary skill in the art are naturally construed as being provided by the present invention.

What is claimed is:

1. An image display device, comprising:
 - a first substrate;
 - a second substrate located to face the first substrate;
 - an electro-optical layer between the first substrate and the second substrate;
 - a plurality of pixel electrodes located between the electro-optical layer and the first substrate;
 - a plurality of switching elements electrically connected with the plurality of pixel electrodes respectively; and
 - a color filter included in a layer between the first substrate and the plurality of switching elements;
 wherein a side of the first substrate opposite to a side thereof facing the electro-optical layer is an image display side.
2. The image display device according to claim 1, further comprising a light blocking layer between the first substrate and the plurality of switching elements.
3. The image display device according to claim 1, wherein no light blocking layer is provided between the second substrate and the electro-optical layer.
4. The image display device according to claim 1, further comprising a cover member located on the image display side with respect to the first substrate.
5. The image display device according to claim 1, further comprising a reflective layer between the second substrate and the electro-optical layer, the reflective layer facing the plurality of pixel electrodes.
6. The image display device according to claim 1, further comprising a common electrode between the first substrate and the electro-optical layer, the common electrode being adjacent to the plurality of pixel electrodes.

18

7. The image display device according to claim 1, wherein the plurality of switching elements are each a transistor including an oxide semiconductor.

8. The image display device according to claim 1, further comprising a flattening layer located in contact with a surface of the second substrate facing the electro-optical layer, the flattening layer overlapping the plurality of pixel electrodes as seen in a plan view.

9. The image display device according to claim 1, wherein:

- the first substrate is formed of polyimide; and
- the color filter is located in contact with the first substrate.

10. The image display device according to claim 1, wherein:

- the electro-optical layer is a liquid crystal layer;
- the image display device further includes:
 - a monomer contained in the liquid crystal layer; and
 - a resin structural body formed by polymerization of the monomer and provided in a region of the liquid crystal layer, the region being between the plurality of pixel electrodes and overlapping a light blocking layer as seen in a plan view.

11. The image display device according to claim 1, further comprising a signal receiver and a signal transmitter receiving and transmitting a video signal;

wherein:

- one of the signal receiver and the signal transmitter is located on the side of the first substrate facing the electro-optical layer;
- an external circuit is located on a side of the second substrate opposite to a side thereof facing the electro-optical layer; and
- the other of the signal receiver and the signal transmitter is located in the external circuit and faces the one of the signal receiver and the signal transmitter.

12. The image display device according to claim 1, further comprising a backlight unit located on a side of the second substrate opposite to a side thereof facing the electro-optical layer.

13. The image display device according to claim 1, further comprising:

- a flexible printed circuit located on the side of the first substrate facing the electro-optical layer; and
- a backlight unit located on a side of the second substrate opposite to a side thereof facing the electro-optical layer;

wherein the flexible printed circuit is folded to face a side of the backlight unit opposite to a side thereof facing the second substrate.

14. The image display device according to claim 13, wherein the flexible printed circuit entirely overlaps the first substrate as seen in a plan view.

15. The image display device according to claim 14, wherein:

- the backlight unit includes a light guide plate and a light source located to the side of the light guide plate;
- the flexible printed circuit has an opening; and
- the light source is located in the opening.

16. The image display device according to claim 2, wherein no light blocking layer is provided between the second substrate and the electro-optical layer.

17. The image display device according to claim 2, further comprising a cover member located on the image display side with respect to the first substrate.

18. The image display device according to claim 3, further comprising a cover member located on the image display side with respect to the first substrate.

* * * * *