

June 27, 1961

A. RODRIGUEZ VILLA ET AL

2,989,923

DETONATOR

Filed Jan. 20, 1958

3 Sheets-Sheet 1

FIG. 1

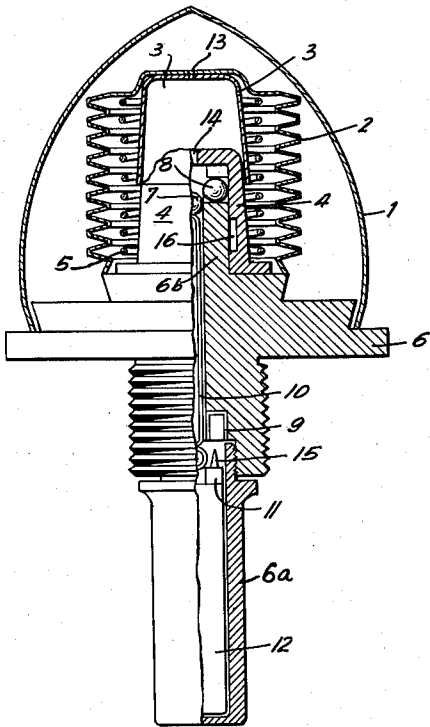
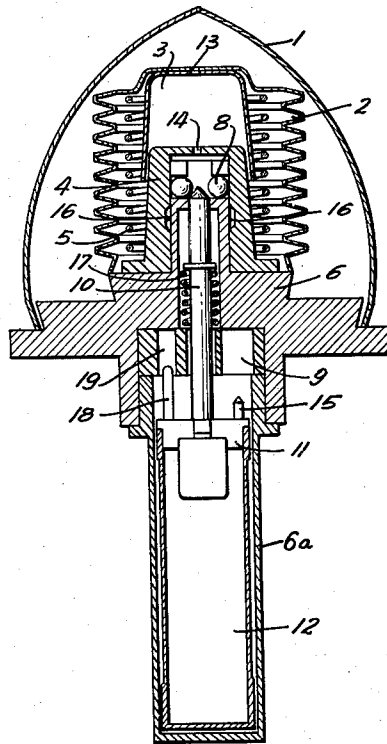

FIG. 2



INVENTORS
Andrés Rodríguez Villa
Fernando Pons
BY
Michael S. Spikes
ATTORNEY

June 27, 1961

A. RODRIGUEZ VILLA ET AL

2,989,923

DETONATOR

Filed Jan. 20, 1958

3 Sheets-Sheet 3

FIG. 5

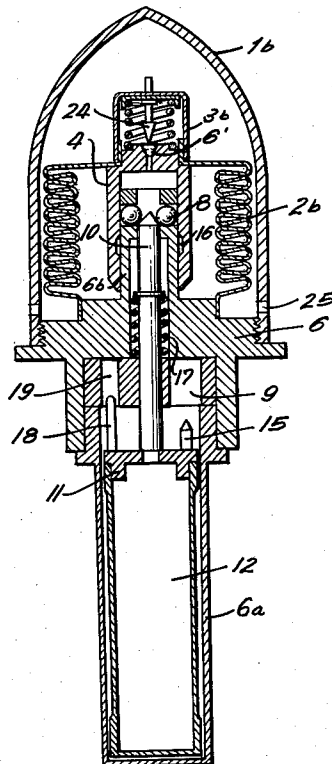

INVENTORS
Andrés Rodríguez Villa
Fernando Pineda
BY
Michael S. Stiller
ATTORNEY

1

2,989,923

DETONATOR

Andres Rodriguez Villa, Alcalá 120-7° izquierda, and
Fernando Pons, Calle del Darro 18, both of Madrid,
Spain

Filed Jan. 20, 1958, Ser. No. 710,125

Claims priority, application Spain Jan. 19, 1957

18 Claims. (Cl. 102-76)

The present invention relates to a detonator, and more particularly to a detonator for a missile which detonates a charge when the missile hits an object.

It is important that detonators are constructed in such a manner as to permit safe handling during transport and to prevent a detonation of the charge during passage through a gun, and in the vicinity of the firing place. It is apparent that premature detonation would endanger the operating personnel which fires the missile.

It is one object of the present invention to provide a detonator which can be safely handled, and which under no circumstances will cause a premature detonation of the charge at the firing range, or during transport of the detonator.

Another object of the present invention is to provide a detonator in which the detonator means are locked during firing of the missile, and are released during the flight of the missile for movement to a detonating position when the missile hits an object.

Another object of the present invention is to provide a resilient membrane means which under the influence of air therein moves between an expanded and a collapsed position for shifting a control member which releases the locking means which lock the detonator means in an inoperative position.

With these objects in view, the present invention mainly consists in a detonator for a missile and comprises, in combination, a casing including a front cap member; a detonator charge; detonator means movable in the casing between an inoperative position and a detonating position engaging the detonator charge; locking means including a control member movable between a locking position holding the detonator means in the inoperative position and a releasing position releasing the detonator means for movement to the detonating position; and a resilient membrane means movable between a collapsed position and an expanded position and being coupled to the control member for moving the same from the locking position to the releasing position. The membrane means have an inner chamber with an air passage to the outside permitting expansion and contraction of the membrane means during flight of the missile. The expanding or contracting membrane means operates the control member of the locking means during the flight of the missile to release the detonator means so that the same move under the action of inertia to the detonating position upon impact of the casing on an object.

According to certain embodiments of the present invention, the membrane means has the shape of bellows, and is normally in an expanded position. Under the influence of inertia directly upon firing of the missile, the membrane means is collapsed, and moves to a coupling position in which it is coupled to the control member. Thereupon, the membrane means slowly expands taking along the control member to its releasing position.

According to another embodiment of the present invention, air is pressed into the membrane means during flight of the missile whereby the membrane means is expanded, and effects release of the detonator means.

According to a further embodiment of the present invention, the membrane means is so mounted in the cap member that the initial inertia effects expansion of the membrane means and coupling of the same in expanded

2

position to the control member. Spring means return the membrane means to collapsed position whereby the control member is taken along and releases the detonator means.

In accordance with a further embodiment of the present invention, air is trapped in the inner chamber of the membrane means, and effects expansion of the membrane means as the missile enters higher layers of air in which the pressure is lower. Expansion of the membrane means effects shifting of the control member to releasing position, and thereby release of the detonator means.

All embodiments of the present invention preferably have a membrane means shaped like a bellows which is moved between expanded and collapsed position during flight of the missile under the influence of the air contained in, or entering the inner chamber of the membrane means.

The membrane means of the present invention is preferably made of rubber, resilient metal, or any other resilient and yieldable material. It is advantageous to provide spring means for urging the membrane means either to collapsed position, or to expanded position.

The novel features which are considered as characteristic for the invention are set forth in particular in the appended claims. The invention itself, however, both as to its construction and its method of operation, together with additional objects and advantages thereof, will be best understood from the following description of specific embodiments when read in connection with the accompanying drawings, in which:

FIG. 1 is a side view, partly in section, illustrating one embodiment of the present invention;

FIG. 2 is a sectional view illustrating a modified embodiment of the present invention;

FIG. 3 is a sectional view illustrating another embodiment of the present invention;

FIG. 4 is a sectional view illustrating a further embodiment of the present invention; and

FIG. 5 is a sectional view illustrating another embodiment of the present invention.

Referring now to the drawings, in which corresponding parts are indicated by the same reference numerals in the different figures, the detonator illustrated in FIG. 1 includes a casing having a rear portion 6a which is threadedly connected to a central portion 6. A front cap member 1 is mounted on the central portion 6. A transfer charge 12 is located in the hollow rear portion 6a. Detonator means 11 including a striker point 15 are movably mounted in the rear portion 6a for movement between an inoperative position, and a detonating position in which the striker points 15 engage the detonator charge 9 which is mounted in a chamber at the rear of the central portion 6. A locking pin 10 abuts at the rear end thereof on the detonator means 11, or on a ball engaging the detonator means 11, and passes through a central bore in the central portion 6. The front end of the pin 10 abuts against a ball 7, which in turn abuts against a plurality of balls 8 located in transverse bores in a central guiding portion 6b of the central portion 6. A cup-shaped control means 4 is slidably mounted on the guide portion 6b, and is movable between the illustrated locking position in which the balls 8 are prevented from outward movement, and releasing position in which the annular recess 16 is located opposite the transverse bores in which the balls 8 are located. In this position, the balls 8 can partly move into the recess 16, and release the central ball 7 so that the pin 10 is free to move forwardly, and permits forward movement of the detonator means 11 and 15 to detonating position.

A membrane means 2 having the shape of bellows has an inner chamber in which the member 4 is located. One end of the membrane means 2 abuts against the central portion 6, and the other end is substantially closed,

3

but has a small opening 13 which is located opposite another small opening 14 in the cup-shaped control member 4. The membrane means includes a cup-shaped coupling member 3 whose conical inner surface cooperates with the conical outer surface of the cup-shaped control member 4. Opening 13 also passes through coupling member 3. The angles of the conical surfaces are approximately 1°. A spring means 5 is connected to the membrane means and urges the same to the illustrated expanded position. However, it is also contemplated to make the membrane means of sufficiently resilient material so that the membrane means tends to assume the expanded position thereof.

The detonator illustrated in FIG. 1 operates in the following manner:

When the missile carrying the detonator is fired, the membrane means 2 moves to a collapsed position due to the inertia of the membrane means 2 and coupling member 3 during acceleration of the device. When the membrane means is in collapsed position, the inner coupling surface of coupling member 3 engages the outer surface of the control member 4 and effects coupling of the membrane means 2 to the control member 4. During further flight of the missile, air gradually and slowly enters through the openings 13 and 14 which are aligned and superimposed in the collapsed position of the membrane means 2, so that the control member 4 is taken along when the membrane means 2 expands under the action of the spring 5. Thereby, the control member 4 moves to the releasing position in which the annular recess 16 is located opposite the locking balls 8, and permits movement of the balls 8 in outward direction whereby the central ball 7 is released, and in turn releases the pin 10, and the detonator means 11, 15. The outward movement of the locking balls 8 is effected during flight by the centrifugal force produced by rotation of the detonator and missile.

When the missile hits an object, the detonator means 11, 15 move forwardly due to inertia, and the striking points 15 engage the detonator charge 9, and detonate the same. Such movement of the detonator means is possible, since the locking pin 10, and the locking ball 7 were previously released.

The release of the locking means is slow, since the openings 13 and 14 are small and expansion of the membrane means 2 can only take place at the speed at which the air enters through the openings 13 and 14. By properly calibrating the openings 13 and 14, the necessary delay can be determined in accordance with the type of missile used.

The membrane means according to the present invention has the advantage that it is normally in expanded position, and is only temporarily tensioned so that the spring 5 is not tensioned during storage of the device. Due to the delay effected by the operation of the membrane means, the charge can never be detonated during firing of the gun, or in the vicinity of the gun. The cap member 1 assures safe handling during transport.

FIG. 2 illustrates an embodiment very similar to the embodiment of FIG. 1. In addition to the members described with reference to FIG. 1, there is provided a spring 17 urging the locking pin 10 in forward direction. The front end of the locking pin 10 is conical and directly abuts against the locking balls 8. The conical end portion of the locking pin 10 urges the balls 8 in outward direction, but outward movement is only possible when the cup-shaped control member 4 is moved by the membrane means to the releasing position in which the recess 16 is located opposite the transverse bores in which the balls 8 are located.

As in the embodiment of FIG. 1, the detonator charge 9 is located opposite the striker point 15 which is mounted on a detonator means 11. In order to assure an exact position of the striker point with respect to the detonator charge 9, the central part of the casing is formed

4

with at least one longitudinal bore 19 in which a pin 18 is guided. Pin 18 is secured to the detonator means 11, and moves with the same. The operation of the device shown in FIG. 2 corresponds to the operation of the embodiment of FIG. 1. At first, the membrane means is collapsed, and is coupled with the control member 4, whereupon it gradually expands and takes along the control member 4 whereby the balls 8 move to a releasing position in the recess 16, and release the pin 10 for forward movement so that the striking points of the detonator means 11 can engage the charge 9 when the missile hits an object.

A further embodiment of the present invention is illustrated in FIG. 3. The detonator means, and the detonator charge, as well as the general arrangement of the locking means is the same as described with reference to FIGS. 1 and 2. However, in the embodiment of FIG. 3, the membrane means 2' has one end secured to the cap member 1, and another end secured to the coupling member 3'. The coupling member 3' is again formed with a small opening 13, and the cup-shaped control member 4 has a corresponding small opening 14. A spring 5' abuts on a flange of member 4, and on the connected ends of the members 3' and 2'. Members 3' and 4 have cooperating slightly conical coupling faces.

The detonator illustrated in FIG. 3 operates in the following manner:

When the missile with the detonator is fired, the membrane means 2' moves to an expanded position due to inertia, and since one end of the membrane means 2' is secured, for example by welding, to the cap member 1, the free end of the membrane means together with the coupling member 3' compress the spring 5', and the coupling member 3' is coupled to the cup-shaped control member 4. In this position no air can pass between members 4 and 3' and opening 13 into the inner chamber between the membrane means, the coupling member and the central portion of the front cap member.

During flight of the missile in coupled position of the members 3' and 4, the membrane means resiliently moves to the collapsed position thereof, taking along the control member 4 which moves to a releasing position in which the recess 16 is located opposite the locking balls 8, permitting releasing movement of the locking balls as previously described. The air contained in the inner chamber of the membrane means escapes through the superimposed openings 13 and 14, and the delay at which the detonator means are released depends on the size of these openings. The spring 5' is small, and insufficient to separate the coupled members 3' and 4, and is mainly provided for the purpose of controlling the movement of the membrane means to expanded position under the action of inertia at the time of firing, and for preventing movement of the membrane means to expanded position during transport of the detonator.

After release of the locking pin 10, the detonator means 11 and 15 are free to move to the detonating position due to inertia created by the impact of the missile on an object.

In the embodiment of FIG. 4, parts corresponding to similar parts in the previously described embodiments are indicated by the same reference numerals. It will be noted that the locking means, and the detonator means are substantially the same as described with reference to FIGS. 2 and 3. In the embodiment of FIG. 4, the control member 4a is slidable on the guide portion 6b of the central portion 6 of the casing, and has an annular recess 16 cooperating with the locking balls 8, as previously described. However, the membrane means 2a is not temporarily coupled with the control member 4a, but is fixedly connected to the same at one closed end thereof. The other end of the membrane means 2a is secured to a member 6c which is threadedly connected to the central portion 6. Member 6c has air passages 22 communicating with the inner chamber between the membrane means 2a, and the control member 4a. The cap member 1a is fixedly secured

5

to member 6c and forms an outer chamber surrounding the membrane means 2a, the outer chamber communicating through passages 23 with the outside. Passages 23 pass through an outer jacket member 20 which is fixedly secured to the portion 6, and has a front aperture 21. The outer jacket member 20 defines with the cap member 1a a pressure air chamber.

Preferably, the openings 21 and 23 are closed by a cover consisting of a plastic material during transport of the detonator in order to prevent dust from entering into the device.

The detonator illustrated in FIG. 4 operates in the following manner. When the missile is accelerated, air enters through the aperture 21 into the pressure air chamber 22, and passes through the passages 22 into the inner chamber in the membrane means 2a. Due to the dynamic pressure exerted by the air in the moving missile, the membrane means 2a is moved to an expanded position, and takes along the control member 4a which effects release of the locking means as previously described. In the expanded position of the membrane means 2a, the recess 16 is located opposite the balls 8, and permits lateral movement of the balls 8 so that the locking pin 10 is free to move in forward direction. Thereby, the detonator means 11 and 15 are also free to move forwardly into engagement with the charge 9 when the detonator hits an object, and the casing with the detonator charge 9 is stopped. The outer chamber between the cap member 1a and the membrane means 2a communicates with the outside through passages 23, but the dynamic pressure of the air pressed into the aperture 21 is, of course, greater than the pressure in the outer chamber so that the membrane means can easily expand.

It is therefore apparent that in the embodiment of FIG. 4 the relative air speed between the moving missile and the atmosphere is used for releasing the locking means which normally lock the detonator means.

In the embodiment of FIG. 5, the lower atmospheric pressure in the higher layers of the atmosphere is used for releasing the locking means. The general construction of the locking means used in the embodiment of FIG. 5 is the same as described with reference to the other embodiments. The membrane means 2b is secured at one end to the central member 6, and has at the other end thereof a member 3b which carries a movable valve member 24 which is spring-loaded, and is normally in the illustrated position. The control member 4 has a valve seat 6' cooperating with the valve member 24, and communicating with passages in the interior of the guide member 6b. The cap 1b has openings 25 connecting the chamber outside of the membrane means and within the cap member with the atmosphere.

The detonator illustrated in FIG. 5 operates in the following manner:

When the missile is fired, the valve member 24 closes the valve seat 6' due to inertia movement. A small amount of air is trapped in the inner chamber within the membrane means 2b. As the missile rises to the higher layers of the atmosphere, the pressure in the outer chamber between the cap member 1b and the membrane means 2b is reduced due to the provision of the openings 25. Therefore, the pressure in the interior of the membrane means exceeds the pressure outside of the same, and the membrane means 2b expands and takes along the control member 4 which is moved to a releasing position in which the annular recess 16 releases the locking balls 8, whereby the locking pin 10, and the detonator means 11 and 15 are also released. Thereby the detonator means are free to move into the detonator charge 9 when the missile hits an object and the casing of the detonator is stopped. A plastic cover may be provided for closing the openings 25 during transport of the detonator, whereby entering of dust into the interior of the device is prevented.

It will be understood that each of the elements described above, or two or more together, may also find

6

a useful application in other types of detonators differing from the types described above.

While the invention has been illustrated and described as embodied in a detonator including a membrane means having the shape of bellows, and effecting a delayed release of locking means locking the detonator means during transport and firing of the missile, it is not intended to be limited to the details shown, since various modifications and structural changes may be made without departing in any way from the spirit of the present invention.

Without further analysis, the foregoing will so fully reveal the gist of the present invention that others can by applying current knowledge readily adapt it for various applications without omitting features that, from the standpoint of prior art, fairly constitute essential characteristics of the generic or specific aspects of this invention and, therefore, such adaptations should and are intended to be comprehended within the meaning and range of equivalence of the following claims.

What is claimed as new and desired to be secured by Letters Patent is:

1. Detonator for a missile comprising, in combination, a casing including a front cap member; a detonator charge in said casing; detonator means located in said casing rearwardly of said detonator charge and movable between an inoperative position and a detonating position engaging said detonator charge; locking means including a control member movable in said casing between a locking position holding said detonator means in said inoperative position and a releasing position releasing said detonator means for movement to said detonating position, said control member having an outer conical coupling surface; and a resilient membrane means located in said cap member and being movable between a collapsed position and an expanded position, said membrane means including a conical coupling member having an inner coupling surface coupled to said control member at least in one of said positions of said membrane means for moving said control member from said locking position to said releasing position while moving from said one of said positions thereof to the other of said positions thereof, said membrane means having an inner chamber with an air passage to the outside permitting movement of said membrane means between said positions thereof during flight of the missile for moving said control member to said releasing position during flight of the missile whereby said detonator means is free to move under the action of inertia to said detonating position upon impact of said casing on an object.

2. Detonator for a missile comprising, in combination, a casing including a rear portion, a center portion having a forwardly projecting guide portion, and a front cap member mounted on said center portion and housing said guide portion; a detonator charge in said center portion of said casing; detonator means located in said rear portion movable between an inoperative position and a detonating position engaging said detonator charge; locking means including elongated means engaging at the rear end thereof of said detonator means and having a front end projecting into said guide portion, locking balls mounted in said guide portion engaging said front end of said elongated means, a control member movably mounted on said guide portion for movement between a locking position engaging said balls and preventing movement of the same and a releasing position, said control member being formed with at least one recess permitting movement of said balls to a position releasing said front end of said elongated means in said releasing position of said control member for releasing said detonator means for movement to said detonating position; and a resilient membrane means located in said cap member and being movable between a collapsed position and an expanded position, said membrane means being coupled to said control member at least in one of said posi-

7

tions of said membrane means for moving said control member from said locking position to said releasing position while moving from said one of said pistons thereof to the other of said positions thereof, said membrane means having an inner chamber with an air passage to the outside permitting movement of said membrane means between said positions thereof during flight of the missile for moving said control member to said releasing position during flight of the missile whereby said detonator means is free to move under the action of inertia to said detonating position upon impact of said casing on an object.

3. A detonator as set forth in claim 2 wherein said guide portion has a longitudinal center bore receiving said front end of said elongated means, a plurality of transverse bores extending from said center bore to the outside of said guide portion and movably housing said locking balls, and wherein said control member surrounds said guide portion and has an inner surface closing said transverse bores in said locking position, said recess in said control member being an annular recess in said inner surface located opposite said transverse bores in said releasing position of said control member.

4. A detonator as set forth in claim 3 and including spring means abutting on said center portion and on said pin for urging said pin against said locking balls.

5. A detonator as set forth in claim 2 wherein said center portion has at least one longitudinal guide bore, and wherein said detonator means include at least one guide pin projecting into said guide bore for guiding said detonator means during movement to said detonating position.

6. A detonator for a missile comprising, in combination, a casing including a rear portion, a center portion having a forwardly projecting guide portion formed with a longitudinally extending central bore, and a front cap member mounted on said center portion and housing said guide portion; a detonator charge in said center portion of said casing; detonator means located in said rear portion movable between an inoperative position and a detonating position engaging said detonator charge; locking means including a locking pin abutting at the rear end thereof on said detonator means and having a front end portion passing through central bore in said guide portion, control means movably mounted on said guide portion for movement between a locking position locking said locking pin and said detonator means and a releasing position releasing said locking pin and said detonator means for movement to said detonating position; a resilient membrane means having the shape of bellows, said membrane means having an inner chamber with an air passage to the outside of said membrane means, said control means and said guide portion being located in said inner chamber, said membrane means being located in said cap member and being movable between a collapsed position and an expanded position, said membrane means being coupled to said control means at least in one of said positions of said membrane means for moving said control means from said locking position to said releasing position while moving from one of said positions thereof to the other of said positions thereof so that when air in said inner chamber effects movement of said membrane means between said positions thereof during flight of the missile, said control means is moved to said releasing position and said detonator means is free to move under the action of inertia to said detonating position upon impact of said casing on an object.

7. A detonator for a missile comprising, in combination, a casing including a rear portion, a center portion having a forwardly projecting guide portion formed with a longitudinally extending central bore, and a front cap member mounted on said center portion and housing said guide portion; a detonator charge in said center portion

8

tion movable between an inoperative position and a detonating position engaging said detonator charge; locking means including a locking pin abutting at the rear end thereof on said detonator means and having a front end portion passing through central bore in said guide portion; control means including a cup-shaped means having a small opening and being movably mounted on said guide portion for movement between a locking position locking said locking pin and said detonator means and a releasing position releasing said locking pin and said detonator means for movement to said detonating position; a resilient membrane means having the shape of bellows, said membrane means having an inner chamber with an air passage to the outside of said membrane means and with a small opening opposite said opening in said cup-shaped means, said control means and said guide portion being located in said inner chamber, said membrane means being located in said cap member and being movable between a collapsed position and an expanded position, said openings being superimposed in said collapsed position, and said membrane means being coupled at least in said collapsed position to said control means for moving said control means from said locking position to said releasing position while moving from said collapsed position to said expanded position so that when air entering said inner chamber through said superimposed openings effects movement of said membrane means to said expanded position thereof during flight of the missile, said control means is moved to said releasing position and said detonator means is free to move under the action of inertia to said detonating position upon impact of said casing on an object.

8. A detonator as set forth in claim 7 wherein said membrane means tends to resiliently assume said expanded position and is adapted to be moved by inertia to said collapsed position so as to be coupled to said control means upon firing of the missile so that said membrane means is coupled during the first part of the flight of the missile to said control means and slowly moves with the same to said expanded position during the flight of the missile.

9. A detonator as set forth in claim 7 wherein said membrane means has one end abutting on said central portion and a closed end formed with said small opening, and includes a coupling member having an inner conical coupling surface located at said closed end; wherein said cup-shaped means has an outer conical surface in coupling engagement with said inner surface of said coupling member when said membrane means is in collapsed position; and resilient means urging said membrane means to said expanded position, said membrane means adapted to be moved to said collapsed position by inertia upon firing of the missile so that during the first part of the flight said coupling member is coupled to said control means, and slowly moves with the same to said releasing position while said membrane means moves to said expanded position.

10. A detonator for a missile comprising, in combination, a casing including a rear portion, a center portion having a forwardly projecting guide portion formed with a longitudinally extending central bore, and a front cap member mounted on said center portion and housing said guide portion; a detonator charge in said center portion of said casing; detonator means located in said rear portion movable between an inoperative position and a detonating position engaging said detonator charge; locking means including a locking pin abutting at the rear end thereof on said detonator means and having a front end portion passing through central bore in said guide portion, control means including a cup-shaped means having a small opening and a coupling member secured to one end of said resilient membrane means and having a small opening opposite said opening in said cup-shaped means, said coupling member having an inner coupling surface

9

cooperating with the outer surface of said cup-shaped means, said membrane means and said coupling member defining an inner chamber, said membrane means being located in said cap member and having the other end thereof secured to the same, said membrane means being movable with said coupling member between a collapsed position and an expanded position, said openings in said cup-shaped means and in said coupling member being superimposed in said expanded position of said membrane means, and said coupling member being coupled to said control means in said expanded position for moving said control means from said locking position to said releasing position while moving from said expanded position to said collapsed position; and resilient means abutting on said central portion and urging said membrane means to said collapsed position so that said coupling member is coupled to said control means during the first part of the flight of the missile by inertia movement, whereupon said membrane means moves to said collapsed position with said cup-shaped means when air enters said inner chamber through said openings whereby said control means move to said releasing position and said detonator means is free to move under the action of inertia to said detonating position upon impact of said casing on an object.

11. A detonator for a missile comprising, in combination, a casing including a rear portion, a center portion having a forwardly projecting guide portion formed with a longitudinally extending central bore, and a front cap member mounted on said center portion and housing said guide portion; a detonator charge in said center portion of said casing; detonator means located in said rear portion movable between an inoperative position and a detonating position engaging said detonator charge; locking means including a locking pin abutting at the rear end thereof on said detonator means and having a front end portion passing through central bore in said guide portion, control means movably mounted on said guide portion for movement between a locking position locking said locking pin and said detonator means and a releasing position releasing said locking pin and said detonator means for movement to said detonating position; a resilient membrane means having the shape of bellows closed at one end and abutting at the other end on said central portion, said membrane means having an inner chamber in which said control means and said guide portion are located, said membrane means being located in said front cap member, said front cap member defining an outer chamber surrounding said resilient membrane means and having air passage means communicating with the outside, said membrane means being movable between a collapsed position and an expanded position and having said closed end secured to said control means for moving said control means from said locking position to said releasing position while said membrane means moves from said collapsed position to said expanded position; and an outer jacket enclosing said front cap member and having an aperture at the front end thereof, said outer jacket defining with said front cap member and said central portion a pressure air chamber, said central portion being formed with openings connecting said pressure air chamber with said inner chamber in said membrane means whereby air entering said pressure chamber through said aperture during flight of the missile enters said inner chamber and moves said membrane means to said expanded position whereby said control means is moved to said releasing position and said detonator means is free to move under the action of inertia to said detonating position upon impact of said casing on an object.

12. A detonator for a missile comprising, in combination, a casing including a rear portion, a center portion having a forwardly projecting guide portion formed with a longitudinally extending central bore, and a front cap member mounted on said center portion and housing said guide portion; a detonator charge in said center portion

10

of said casing; detonator means located in said rear portion movable between an inoperative position and a detonating position engaging said detonator charge; locking means including a locking pin abutting at the rear end thereof on said detonator means and having a front end portion passing through the central bore in said guide portion, control means movably mounted on said guide portion for movement between a locking position locking said locking pin and said detonator means and a releasing position releasing said locking pin and said detonator means for movement to said detonating position; said control means having inner air passages and a valve seat communicating with said air passages; a resilient membrane means having the shape of bellows and having one end secured to said central portion and a closed end attached to said control means, said membrane means having an inner chamber communicating with said air passages through said valve seat, said membrane means being located in said front cap member and movable between a collapsed position and an expanded position for moving said control means from said locking position to said releasing position, said membrane means defining with said cap member an outer chamber, said cap member having openings connecting said outer chamber with the outside; and a valve member mounted on said closed end of said membrane means cooperating with said valve seat so that said valve member closes said air passages and inner chamber due to inertia movement at the beginning of the flight of the missile, whereupon the air in said inner chamber expands and moves said membrane means to said expanded position so that said control means is moved to said releasing position and said detonator means is free to move under the action of inertia to said detonating position upon impact of said casing on an object.

13. A detonator as set forth in claim 7 wherein said guide portion is formed with transverse bores connected to said central bore and to the outer surface of said guide portion; and including locking balls in said transverse bores; and wherein said cup-shaped means closes said transverse bores in locking position, and opens said transverse bores in releasing position for movement of said locking balls into a position releasing said locking pin.

14. A detonator as set forth in claim 10 wherein said guide portion is formed with transverse bores connected to said central bore and to the outer surface of said guide portion; and including locking balls in said transverse bores; and wherein said cup-shaped means closes said transverse bores in locking position, and opens said transverse bores in releasing position for movement of said locking balls into a position releasing said locking pin.

15. A detonator as set forth in claim 11 wherein said guide portion is formed with transverse bores connected to said central bore and to the outer surface of said guide portion; and including locking balls in said transverse bores; and wherein said control means closes said transverse bores in locking position, and opens said transverse bores in releasing position for movement of said locking balls into a position releasing said locking pin.

16. A detonator as set forth in claim 12 wherein said guide portion is formed with transverse bores connected to said central bore and to the outer surface of said guide portion; and including locking balls in said transverse bores; and wherein said control means closes said transverse bores in locking position, and opens said transverse bores in releasing position for movement of said locking balls into a position releasing said locking pin.

17. A detonator as set forth in claim 16 and including a spring urging said locking pin against said locking balls.

18. Detonator for a missile comprising, in combination, a casing including a front cap member; a detonator charge in said casing; detonator means located in said casing rearwardly of said detonator charge and movable between an inoperative position and a detonating position engaging said detonator charge; locking means including a control member movable in said casing between

11

a locking position holding said detonator means in said inoperative position and a releasing position releasing said detonator means for movement to said detonating position; and a resilient membrane means located in said cap member and being movable between a collapsed position and an expanded position, said membrane means having the shape of bellows and including a coil spring urging said membrane means to said expanded position, said membrane means being coupled to said control member at least in one of said positions of said membrane means for moving said control member from said locking position to said releasing position while moving from said one of said positions thereof to the other of said positions thereof, said membrane means having an inner chamber with an air passage to the outside permitting movement of said membrane means between said positions thereof during flight of the missile for moving said control member to said releasing position during flight of the missile whereby said detonator means is free to

12

move under the action of inertia to said detonating position upon impact of said casing on an object.

References Cited in the file of this patent

UNITED STATES PATENTS

559,495	Rapieff -----	May 5, 1896
1,537,208	Wiley -----	May 12, 1925
1,687,484	Van Essen -----	Oct. 9, 1928
2,068,708	Reed -----	Jan. 26, 1937
2,438,853	Hebard -----	Mar. 30, 1948
2,513,185	Lauritsen -----	June 27, 1950
2,750,890	Leonard -----	June 19, 1956
2,754,760	Wynn -----	July 17, 1956
2,807,210	Wales -----	Sept. 24, 1957

FOREIGN PATENTS

742,598	France -----	Jan. 4, 1933
345,315	Italy -----	Dec. 28, 1936