

No. 747,704.

PATENTED DEC. 22, 1903.

M. F. HAVENS.
PLAITING MACHINE.
APPLICATION FILED FEB. 21, 1903.

NO MODEL.

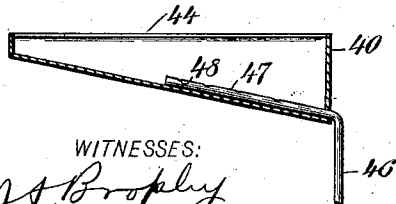
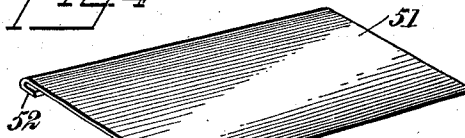
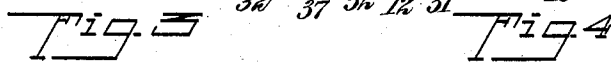
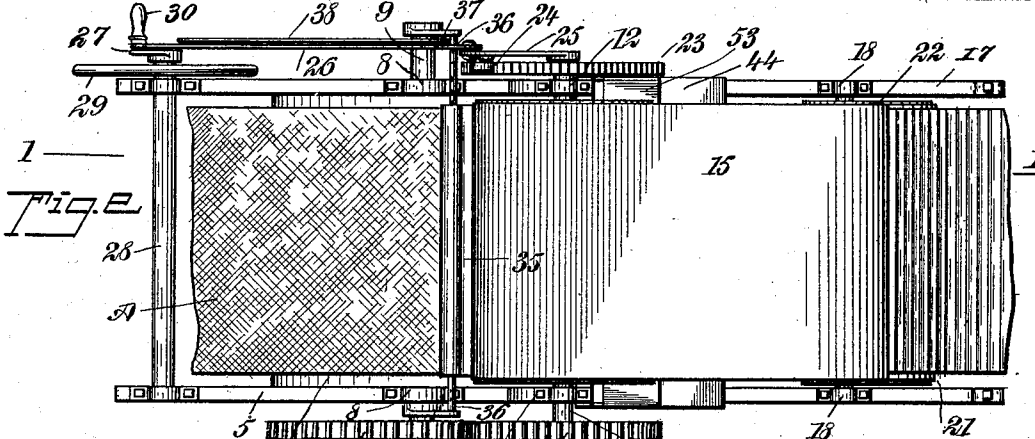
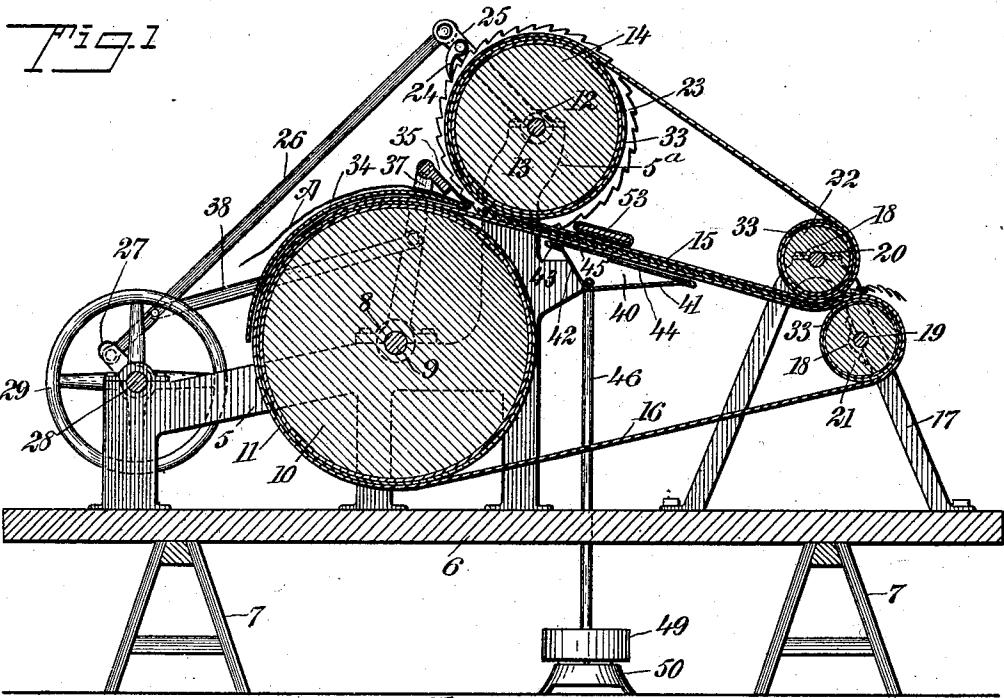

WITNESSES:

J. S. Brophy
N. A. Bouchard

INVENTOR
Mary F. Havens
BY *Mumford*
ATTORNEYS.

UNITED STATES PATENT OFFICE.

MARY F. HAVENS, OF NEW YORK, N. Y.

PLAITING-MACHINE.

SPECIFICATION forming part of Letters Patent No. 747,704, dated December 22, 1903.

Application filed February 21, 1903. Serial No. 144,444. (No model.)

To all whom it may concern:

Be it known that I, MARY F. HAVENS, a citizen of the United States, and a resident of the city of New York, borough of Manhattan, in the county and State of New York, have invented new and useful Improvements in Accordion-Plaiting Machines, of which the following is a full, clear, and exact description.

This invention relates to improvements in machines for plaiting fabrics by which I am able to rapidly and economically lay the fabric in plaits or folds, steam and dry the plaits, and subject the prepared fabric to pressure during its progress through the machine, so that it will emerge in a set and finished condition, these steps in the treatment of the fabric being carried out in a manner which does not expose the fabric to injury from overheated rollers or other devices which have a tendency to burn or scorch the goods.

Further objects and advantages of the invention will appear in the course of the subjoined description, and the novelty will be defined in the annexed claims.

Reference is to be had to the accompanying drawings, forming a part of this specification, in which similar characters of reference indicate corresponding parts in all the figures.

Figure 1 is a vertical sectional elevation through a plaiting-machine constructed in accordance with my invention, the plane of the section being indicated by the dotted line 1 1 of Fig. 2. Fig. 2 is a plan view of the machine shown by Fig. 1. Fig. 3 is a detail sectional view taken longitudinally through the steaming-pan, showing the arrangement of the steam-feed pipe therein, said Fig. 3 being a section transverse of the machine—*i. e.* at right angles to the section of the machine and of the pan shown in Fig. 1; and Fig. 4 is a detail perspective view of a cover adapted to be fitted removably to a part of the pan shown by Fig. 3.

In carrying my invention into practice I employ a suitable construction of frame having side pieces 5, joined by a number of transverse shafts, which will be hereinafter more specifically referred to, the said frame being secured in a suitable way to a foundation or base 6, which may or may not be supported

in a raised position by suitable trestles 7. The sides 5 of the frame are equipped with shaft-bearings 8, adapted to support a transverse shaft 9 of a large feed roller or drum 10, the latter being provided with a jacket 11, of any suitable material. The side pieces of the frame are also provided with upwardly-extending members 5^a, having shaft-bearings 12, which accommodate a shaft 13 of an upper feed drum or roller 14. This upper roller or drum is of smaller diameter than the lower roller 10, and the shafts 9 13 of the two rollers are in horizontally parallel planes.

An important feature of this invention consists in arranging the upper smaller feed-roller 14 in a position in the rear of the lower feed-roller 10, whereby the upper feed-roller is spaced with relation to the roller 10 in a way to permit the free operation of the folding or plaiting knife and also allow the easy and unobstructed introduction of the plaits or folds of the fabric between the upper and lower cooperating aprons 15 16, as will hereinafter appear.

The base or foundation 6 is provided at or near its rear portion with standards 17, equipped with pairs of shaft-bearings 18, which receive the shafts 19 20 of a pair of rear rollers 21 22. The roller 21 lies in the rear of the feed-roller 10 in order to support the rear portion of the lower apron 16, while the other roller 22 is disposed in a horizontal plane below the axis of the upper feed-roller 14, said roller 22 cooperating with the feed-roller 14 to support the upper apron 15. It will thus be seen that the feed-rollers 10 14 and the rollers 21 22 support the two aprons in positions for the upper lead of the lower apron 16 to run parallel to the lower lead of the upper apron 15, whereby the opposing leads of the two aprons serve as a means for carrying the plaited fabric through the machine, and they also cooperate in pressing the fabric after it is plaited or folded by the operation of the plaiting-knife.

Any suitable means may be employed to simultaneously rotate the feed-rollers in opposite directions and with step-by-step movements; but in the drawings I have shown a ratchet feed mechanism for rotating the upper feed-roller 14, which is geared to the

lower feed-roller 10. This feed-roller 14 is provided at one end with a ratchet 23, with which engages a pawl 24, that is mounted on a vibratory lever 25, the latter being hung loosely on the shaft 13 of said feed-roller 14. This lever 25 is connected by a pitman 26 with a suitable form of crank 27, attached to an operating-shaft 28, the latter being journaled in proper bearings at the front part of the frame 5. This shaft is equipped with a balance-wheel 29, and the crank 27 I provide with a hand-piece 30 for the convenient rotation of the shaft 28 by hand; but it will be understood that any suitable type of power device may be applied to the shaft 28 for operating the machine by power, if desired.

The roller-shaft 13 is provided at the opposite end from the ratchet 23 with a spur-gear 31, having intermeshing engagement with a gear 32 on the shaft 9 of the feed-roller 10, thus driving said feed-roller 10 directly from and in an opposite direction to the feed-roller 14. The gearing 31 32 between the front feeder-rollers 10 14 should be so proportioned as to make the two rollers turn at the same peripheral speed, and these rollers are thus effective in driving the aprons of the pair at equal speed, thus insuring the proper carriage of the work through the machine without disarranging the plaits or folds.

In my machine neither of the rollers 10 14 21 22 is designed to be heated by steam or other medium, but, on the contrary, each roller is equipped with a soft fibrous jacket of any suitable fabric, the jackets of the rollers 14 21 22 being indicated at 33 in Fig. 1.

34 designates a metallic curved hood which is made from a single piece of plate metal bent to the proper curve. This hood is arranged in overhanging relation to the feed-roller 10, and it is supported in a suitable way on the side members 5 of the frame, one edge of the hood projecting into the space or throat, which is formed by the adjacent portions of the aprons 15 16 at the point where they pass around the rollers 10 14. Over this hood 34 operates the plaiting knife or blade 35, one edge of which is attached to a pivotal rod 36, that is mounted on the upper ends of the rocking arms 37, the latter being loosely fitted on the shaft 9 of the large feed-roller 10. The arms 37 may be moved back and forth by connection with the operating-shaft 28, and in the drawings this connection is in the form of a link 38, pivoted at one end to one arm 37 and at its other end to the pitman 26.

An important feature of the present invention is the steam-pan 40, which is arranged below the upper lead of the apron 16 and in a position between the feed-drum 10 and the idle roller 21. This pan 40 has a chamber, (shown more particularly by Fig. 3,) and it is arranged in a horizontal position between the members 5 of the frame, the end portions of said pan being fastened in a suitable way to said frame members in order that the pan may occupy a stationary position adjacent

to said apron 16. The bottom of the pan consists of two inclined members 41 42, the member 42 rising abruptly from the member 41, which is inclined rearwardly and upwardly toward the upper lead of the apron 16, thereby forming a pocket in the bottom portion of the pan. The member 42 is equipped at the top of the pan with a lip 43, which extends beyond the front edge of the pan and lies close to the upper lead of the apron 16 to serve as a support therefor and prevent sagging of the apron. The rear portion of the steaming-pan is provided with a plate 44, which serves to partially close the open upper side of the pan and is disposed parallel to said upper lead of the apron 16, said plate 44 serving as a drier-plate for the plaited fabric as it is carried through the machine by the rearward traveling motion imparted to the aprons 15 16. The front edge of the drier-plate terminates short of the lip 43 of the pan, thus leaving an unobstructed opening 45 in the upper side of the pan directly below the apron 16. Steam is supplied to the chamber of the pan 40 by a vertical pipe or tube 46, the same entering one side of the pan at the pocket formed by the junction of the members 41 42, comprising the bottom of the pan. This pipe 46 is provided with an elbow or short length 47, having steam-outlet orifices 48 in the upper side thereof, as shown by Fig. 3. The bottom portion of the pan 40 is inclined lengthwise from one side toward the other, as also shown by Fig. 3, and the water resulting from the condensation of the steam is free to pass into this pocket of the pan, to return through the openings 48 and the pipe 46 back to a suitable form of steam-boiler.

The steam-generating appliances may be of any suitable character; but in Fig. 1 I have shown the boiler 49 as consisting of a flat cylindrical vessel arranged to rest directly upon a gas-stove 50.

In the operation of the machine a fabric of any suitable nature (indicated at A in the drawings) is fed over the hood 34 into the throat between the aprons 15 16 and below the plaiting-knife 35. The shaft 28 is operated to impart motion to the pitman 26 and the link 38, thus giving reciprocating motion to the plaiting-knife 35 and a rotary step-by-step motion to the feed-rollers 10 14. The knife engages with the fabric to lay the same in plaits or folds, and this fabric is carried by the traveling motion imparted to the aprons 15 16 over the steaming-pan 40. The parallel leads of the cooperating aprons 15 16 retain the plaits or folds of the fabric in the condition in which they are formed by the knife, and these leads also press the plaited fabric, so that it will retain the desired condition. The fabric is exposed to the action of the heat and moisture arising from the steaming-pan 40, thus causing the folds to become set and resulting in a superior article of work. It is sometimes desirable, how-

ever, to cut off the passage of steam to certain portions of the fabric—as, for instance, when making a plaited fabric with a loose flounce—and to attain this end, I provide a plate 51, shown more particularly by Fig. 4, said plate having inwardly-turned edges 52, forming flanges adapted to engage with the lip 43 at one end of the steaming-pan and the folded edge at the rear edge of said pan. The plate 51 is arranged to extend across the pan in order to close a portion of the opening 45 therein, and this plate may be adjusted lengthwise of the pan to cover any desired portion thereof.

Another feature of my machine is a pressing-board 53, which is arranged in a horizontal position across the lower lead of the upper apron 15. This pressing-board extends across the machine so as to have its end portions supported by the side pieces 5, and said board lies over the opening 45 in the steaming-pan. The board is made of wood or equivalent material adapted to retain the moisture arising from the pan, and this board presses on the apron 15 and the interposed fabric between the two aprons 15 16, whereby the board serves as a means to retain the moisture by preventing the free escape of the steam and coöperates with the aprons in pressing the steamed and plaited fabric. The pressing-board 53 is lined on its under side with one or more layers of cloth, which tend to retain the heat as well as to close up the open part of the steaming-pan. The steam-pan is peculiarly shaped with a view to securing the desired degree of heat and pressure of the steam on the fabric. As shown, the pan tapers toward one end, it is of small dimensions, and it has an opening of comparatively small area for the escape of steam, whereby the pan operates in a way to economize the steam and to receive the desired pressure in order to force the steam into the work passing over the open top side of the pan. The open space in the top of the pan, over which the plaited folds are adapted to be carried by the movement of the aprons, provides all the heat and steam required for rapid step-by-step motion of the fabric carried by the aprons.

Special stress is laid on the fact that my machine omits heated rollers, which are liable to burn or scorch the fabrics; but the rollers of my machine are of light construction and inclosed within fabric jackets of a soft material, thus overcoming one of the great objections to plaiting-machines which employ means for heating and pressing the fabric in order to make the plaiting retain its shape.

Another advantage of the invention is the spacing of the inlet ends of the aprons to form the throat, which permits the fabric to easily enter the space between the aprons without resorting to the use of special devices to keep the plaits from falling out at the front of the machine.

Having thus described my invention, I

claim as new and desire to secure by Letters Patent—

1. A plaiting-machine having a pair of front coöperating rollers of different diameters, the smaller roller having its axis disposed in a vertical plane which lies substantially back of the surface of the larger roller, suitable rear rollers, a pair of aprons fitted to said rollers and forming at their front ends a tapering throat, the upper lead of the lower apron extending for a distance in front of the lower lead of the upper apron, and a vibratory knife movable in an arcuate path and having its center of movement coincident with the axis of the lower larger feed-roller, said knife being movable into the throat or space between and substantially up to the point where the adjacent leads of the aprons assume parallel relation.

2. A plaiting-machine having a pair of front coöperating rollers of different diameters, the smaller roller having its axis disposed in a vertical plane which lies substantially back of the surface of the larger roller, suitable rear rollers, a pair of aprons fitted to said rollers and forming at their front ends a tapering throat, the upper lead of the lower apron extending for a distance in front of the lower lead of the upper apron, a curved hood concentric with the lower front roll and having its upper rear edge extended into the throat or space between the aprons, rocking arms mounted on the shaft of the lower roller, and a plaiting-knife carried by said arms in a position to traverse the curved hood and arranged to work in the throat or space between the aprons.

3. A plaiting-machine having endless aprons, a steaming-pan disposed below the upper lead of the lower apron, the bottom of the steaming-pan consisting of reversely-inclined portions disposed transversely across the pan, and said bottom being inclined in the direction of the length of the pan, and a steam-feed pipe having a perforated length disposed in the space formed by the inclined portions of the pan-bottom.

4. A plaiting-machine having endless aprons, a steaming-pan disposed below the upper lead of the lower apron, said pan having its bottom formed by reversely-inclined portions, a drier-plate partially covering the top of the pan and leaving therein an exit-opening, a steam-pipe entering the pan, and a presser device located over the exit-opening of the pan and above the adjacent leads of said aprons.

5. In a plaiting-machine, the combination with endless aprons having adjacent lengths disposed in coöperative relation, of a steaming-pan below the upper lead of the lower apron, and a presser-board supported above the lower lead of the upper apron and over a steam-outlet from said pan.

6. In a plaiting-machine, the combination with a carrier for the plaited fabric, of a steaming-pan disposed below said carrier and

having an outlet arranged to discharge steam directly against the same, a drier-plate over the steaming-pan and below a portion of said carrier, and a presser-board over the fabric-
5 carrier and a steam-outlet from said pan.

7. In a plaiting-machine, the combination with a fabric-carrier, of a steaming-pan having an outlet which directs the steam against said fabric-carrier, and a shiftable cut-off

plate fitted to said pan to partly close the steam-outlet thereof.

In testimony whereof I have signed my name to this specification in the presence of two subscribing witnesses.

MARY F. HAVENS.

Witnesses:

JNO. M. RITTER,
H. T. BERNHARD.