

(No Model.)

2 Sheets—Sheet 2.

J. ADAIR.
MACHINE FOR MIXING OR WORKING DOUGH.

No. 526,986.

Patented Oct. 2, 1894.

Fig. 2.

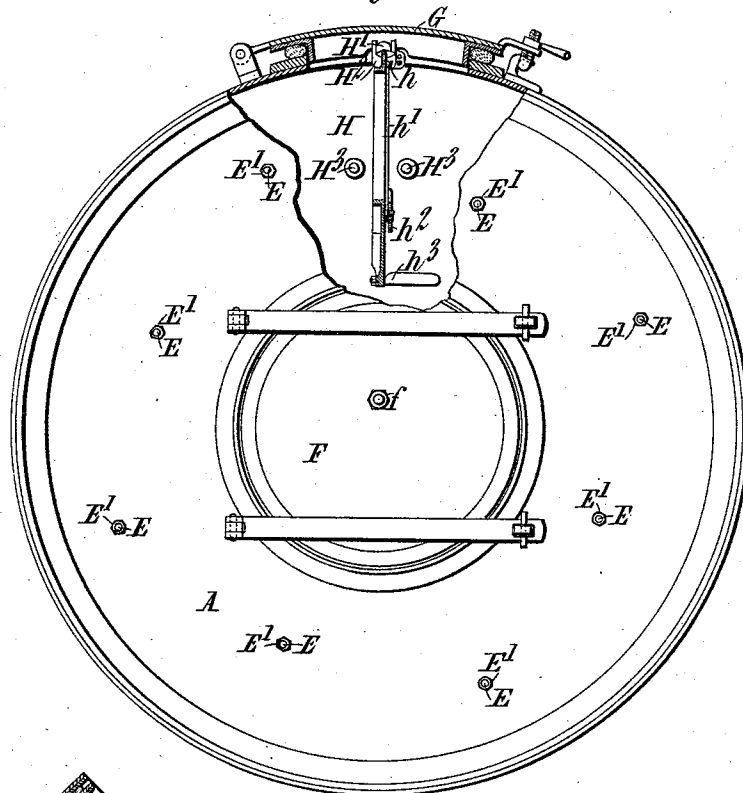
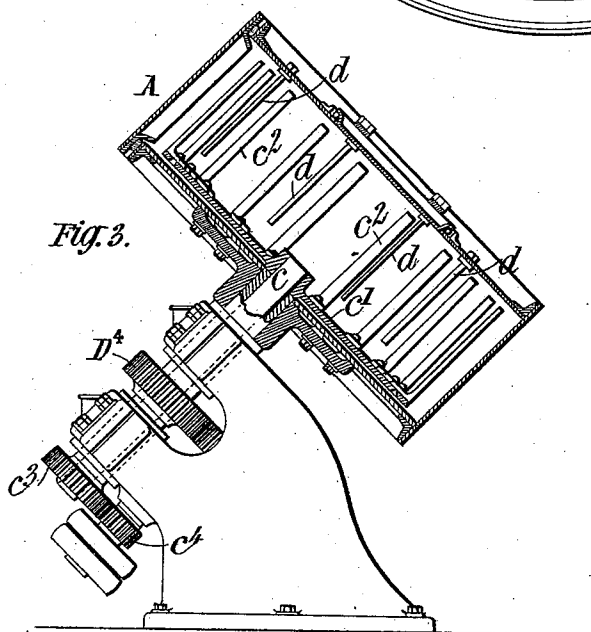

Fig. 3.



Witnesses:
E. W. Rea
Thos. A. Green

Inventor:
John Adair,
By James L. Norris.
Attys.

UNITED STATES PATENT OFFICE.

JOHN ADAIR, OF WATERFORD, IRELAND, ASSIGNOR TO THE ADAIR SYNDICATE, LIMITED, OF LONDON, ENGLAND.

MACHINE FOR MIXING OR WORKING DOUGH.

SPECIFICATION forming part of Letters Patent No. 526,986, dated October 2, 1894.

Application filed March 3, 1894. Serial No. 502,269. (No model.) Patented in England February 24, 1888, No. 2,750, September 26, 1889, No. 15,143, November 23, 1889, No. 18,771, February 1, 1890, No. 1,714, and December 9, 1890, No. 20,123; in Canada October 15, 1892, No. 40,684, and in Victoria October 26, 1892, No. 10,089.

To all whom it may concern:

Be it known that I, JOHN ADAIR, commission agent, a subject of the Queen of Great Britain, residing at Waterford, in the county of Waterford, Ireland, have invented certain new and useful Improvements in Machines for Mixing or Working Dough, (for which I have obtained patents in Great Britain, No. 2,750, bearing date February 24, 1888, No. 15,143, bearing date September 26, 1889, No. 18,771, bearing date November 23, 1889, No. 1,714, bearing date February 1, 1890, and No. 20,123, bearing date December 9, 1890; in Canada, No. 40,684, bearing date October 15, 1892, and in Victoria, No. 10,089, bearing date October 26, 1892,) of which the following is a specification, reference being had to the accompanying drawings.

This invention relates to machinery or apparatus for mixing or working dough.

The chief feature of the said invention relates to the provision in combination with a rotary dough-box of internal wires, bars, rods, or knives through which the dough raised by the rotating box is continually falling. Said wires, bars, rods, or knives are preferably fixed in the dough-box and rotate therewith. They are sometimes however made independent of the dough-box and either remain stationary or are rotated in the same direction as the dough-box, or in the opposite direction. I sometimes also combine rods that are fixed in the dough-box with other rods that are independent thereof.

Another important feature of my said invention relates to the sponge blender as hereinafter described.

In the accompanying drawings, Figure 1 is a vertical central section through the dough-box, and showing also the standard and driving mechanism, the outer end of the shaft being shown in section. Fig. 2 is a side elevation partly in section of the dough-box showing the sponge blender in end elevation. Fig. 3 is a side elevation partly in section showing a modified form of my doughing apparatus having rotary rods which may remain stationary or be driven independently of the box.

Referring to Figs. 1 and 2, A is the rotary dough-box which is secured in any suitable manner, as for example by means of a plate B', to a shaft B which is mounted in bearings in a standard C. Said shaft B may be driven by hand or power gear.

I have shown driving mechanism comprising fast and loose pulleys D, D' mounted on a short shaft to which is keyed a toothed wheel D² that gears with a wheel D³ keyed on the shaft B. Any other suitable driving mechanism may be substituted for that shown.

The dough-box may or may not be formed integral with the plate B'. It is preferably made separate and riveted or bolted thereto. I have shown a cylindrical dough-box built up of wrought iron, but I do not confine myself either to this shape or this material.

Extending across the interior of the dough-box at suitable intervals are a number of wires, or rods or the like E. Said wires are tightened by means of nuts E' screwed on their ends which project through the sides of the box. Any other suitable manner of securing and tightening may be adopted. I do not limit myself to any particular thickness or shape of said wires, or rods or the like (as such may be varied very considerably) or in the direction or position of said rods, the novelty consisting in the use of wires, or rods or the like, in the rotating-box and rotating therewith.

F is a door in the side of the dough-box to provide for obtaining access to the interior.

F' is a rubber or other jointing-ring for making a tight joint and preventing leakage at the door when the machine is at work. I sometimes provide a vent pipe *f* to prevent the accumulation of pressure in the dough-box when steam is used therein. Said pipe *f* projects some distance into the box so that the dough will not be likely to fall there-through or choke the vent.

G is another door hinged to the periphery of the box and may be used for filling and emptying the box.

H is the sponge blender consisting of a plate having pivots H' H' which rest in sockets H², H², secured to the side of the dough-box. Said pivots H', H' are held in place in

the sockets H^2 , H^3 by the door G which when in position is in contact or nearly so with the pivots and prevents the same from rising out of their sockets while allowing the plate to swing quite freely.

H^3 , H^3 are stops to limit the oscillation of the sponge blender as the dough-box rotates. In some cases said stops are fixed quite close to the plate so as to prevent any oscillation whatever.

The plate H has a large opening H^4 formed therein. Along two of the edges of said opening are fixed a number of pegs or projections h . A wire h' is strung across the opening H^4 and passed around the pegs h in the manner indicated in the drawings, and is tightened by the screws h^2 or otherwise. Instead of having one continuous wire stretched across the opening on the sponge blender, I may arrange two or more shorter wires so that they together extend across the opening from one side to the other. Rows of thin rods may be substituted for the wire. Along the lower edge of the sponge blender I fix a number of knives h^3 which project from the face of the plate and assist the blending of the sponge.

The action of this apparatus is as follows:

Flour and water in proper proportions for making a creamy emulsion or sponge are introduced into the box and the latter is then rotated, the sponge blender being in position therein. The sponge blender aided by the transverse wires or rods of the box thoroughly mixes up the contents and soon forms the sponge, that is to say, very much sooner and far more effectively than would be the case were the transverse wires or rods alone relied upon. When the sponge is properly blended, more flour is added sufficient to make a dough, and the sponge blender is removed. The box is then again rotated until the dough is kneaded or formed by the transverse wires or rods.

To provide for conveniently introducing water and steam into the dough-box while the same is rotating, I provide an axial thoroughfare b in the shaft B . b' is a pipe which enters said thoroughfare to deliver the steam or water therein. Leakage is prevented around the pipe b' by means of a packed stuffing-box b^2 .

While the sponge is blending or the dough is mixing, steam may be allowed to flow into the dough-box through the said thoroughfare at the rate required to keep the contents at the proper temperature. Consequently in cold and wintry weather it will be unnecessary to use very hot water for blending sponges. Care however must be taken to prevent the too rapid entry of steam which would injure the ferment. In the ordinary method where there is no steam pipe it often happens during the operation of sponge blending and dough making that the tem-

perature falls considerably, and to make provision for this the water at the start is heated much higher than would be otherwise necessary. Such high heat is injurious as it tends to sour the sponge. By my method of steam heating this objection is overcome, and moreover steam can be very conveniently used to heat the drum preliminarily to a moderate temperature so as to form a hot jacket for the contents during the operations of dough making and sponge blending. My improved method of heating enables the temperature to be regulated as required and maintained during the whole operation. Moreover the box can be very readily scalded and cleaned when required.

In the modified form of dough box shown in Fig. 3 the box A rotates about an inclined axle which is hollow. Said hollow axle contains an internal shaft or axle c , concentric therewith, and projecting into the dough box. To the inner end of said shaft c is fixed a plate c' to which are attached a number of rods or bars c^2 that project across the dough-box and perform the same function as the wires, or rods E , Fig. 1. Said shaft c may be held stationary or it may be rotated through suitable gear wheels c^3 , c^4 . D^4 is a gear wheel for driving the dough-box. In addition to the stationary or rotating bars c^2 , I sometimes provide other bars d d projecting into the dough-box and fixed to the sides thereof.

What I claim is—

1. The combination, with a revoluble dough-box, of wires, rods, or knives extending across the same and fixed thereto, and a sponge blender mounted therein, substantially as described.
2. The combination, with a revoluble dough-box, of wires, rod or knives extending across the same and fixed thereto, and a sponge blender supported on pivots and adapted to swing freely between limiting stops, substantially as described.
3. The combination, with a revoluble dough-box, of wires rod or knives extending across the same and fixed thereto, a sponge blender supported on pivots and adapted to swing freely between limiting stops, an opening in said sponge blender and a wire or wires stretched across said opening, substantially as described.
4. The combination, with a revoluble dough-box, of wires, rod or knives extending across the same and fixed thereto, a sponge blender supported on pivots and adapted to swing freely between limiting stops, an opening in said sponge blender, a wire or wires stretched across said opening, and knives fixed to the sponge blender to project from the face thereof, substantially as described.
5. The combination, with a revoluble dough-box, of wires, rod or knives extending across the same and fixed thereto, a sponge blender supported on pivots and adapted to swing

freely between limiting stops, an opening in
said sponge blender a wire or wires stretched
across said opening, knives fixed to the
sponge blender to project from the face
5 thereof, and a thoroughfare passing through
the axle of the dough-box whereby water and
steam may be introduced into the box with-
out stopping the same, substantially as de-
scribed.

In witness whereof I have hereunto set my 10
hand this 22d day of December, 1893.

JOHN ADAIR.

Witnesses:

JAMES MCCOY,

16 Colbeek Street, Waterford, Solicitor.

JOHN BOYD,

44 Manor Street, Waterford, Solrs. Clerk.