

(No Model.)

3 Sheets—Sheet 1.

T. TRIPP.
CAR BRAKE.

No. 450,761.

Patented Apr. 21, 1891.

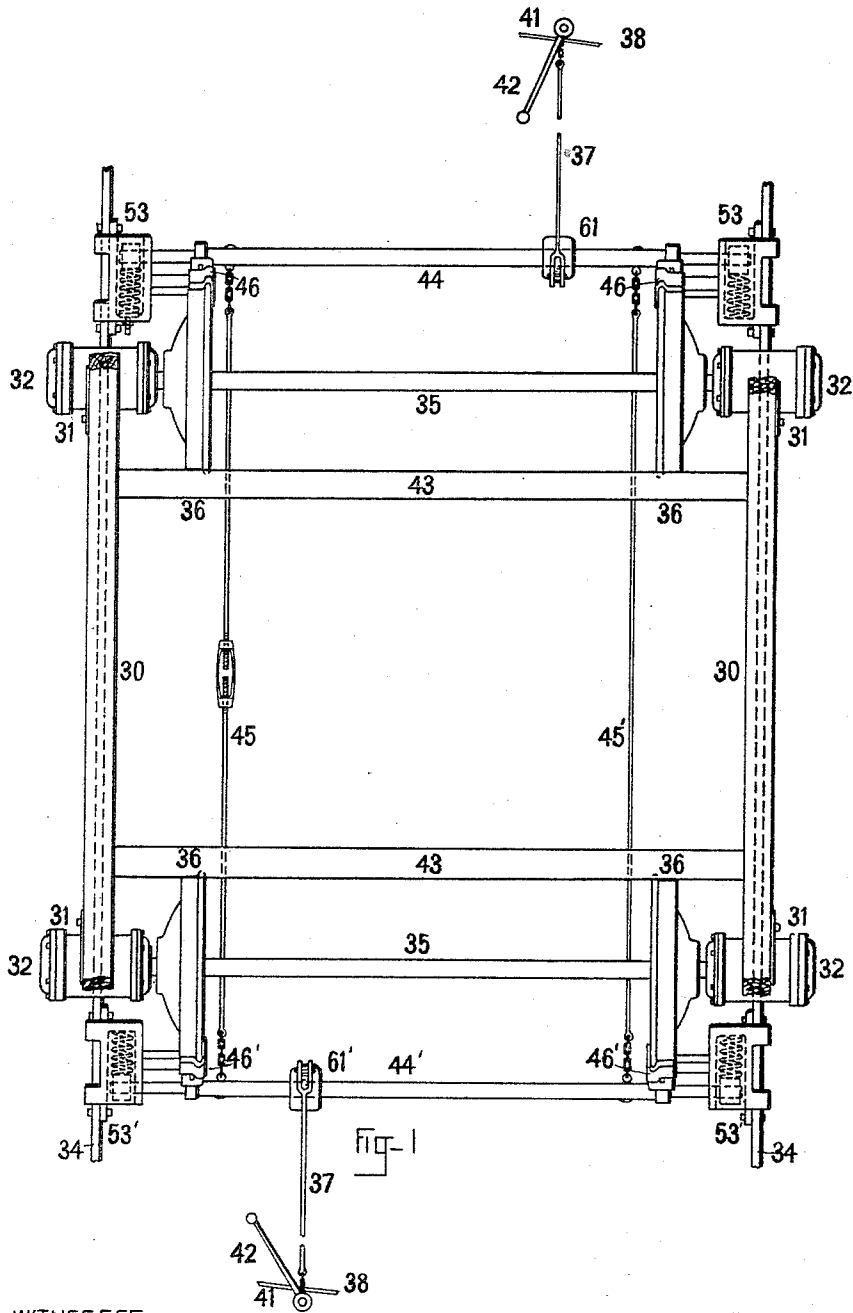

WITNESSES:

Walter L. Perry
J. Edward Porter

INVENTOR.

Thomas Tripp
BY
E. Frank Woodbury
ATTORNEY.

(No Model.)

3 Sheets—Sheet 2.

T. TRIPP.
CAR BRAKE.

No. 450,761.

Patented Apr. 21, 1891.

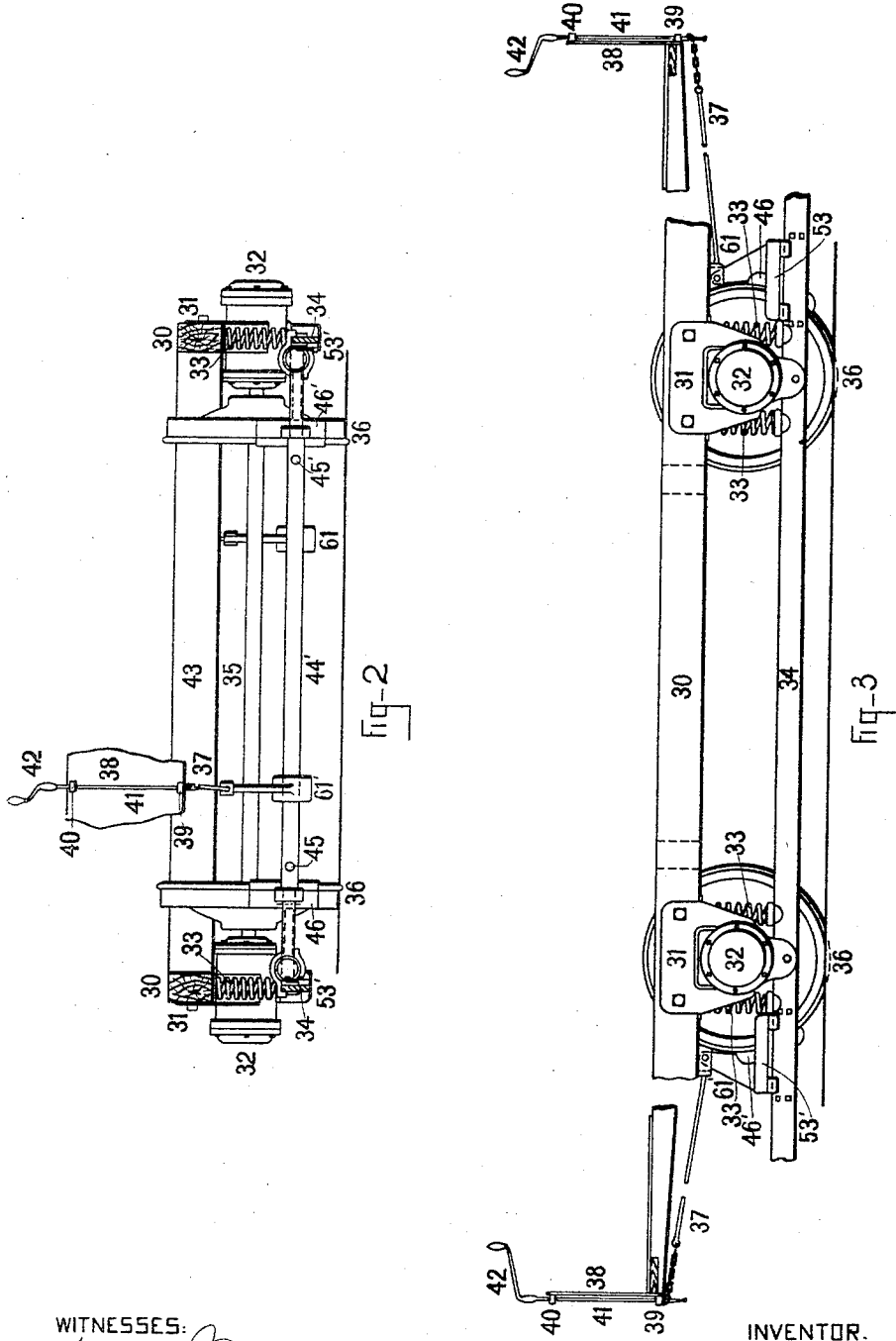

WITNESSES:
Walter L. Perry.
J. Edward Porter.

INVENTOR.
Thomas Tripp
 BY
E. Frank Woodbury
 ATTORNEY—

T. TRIPP.
CAR BRAKE.

No. 450,761.

Patented Apr. 21, 1891.

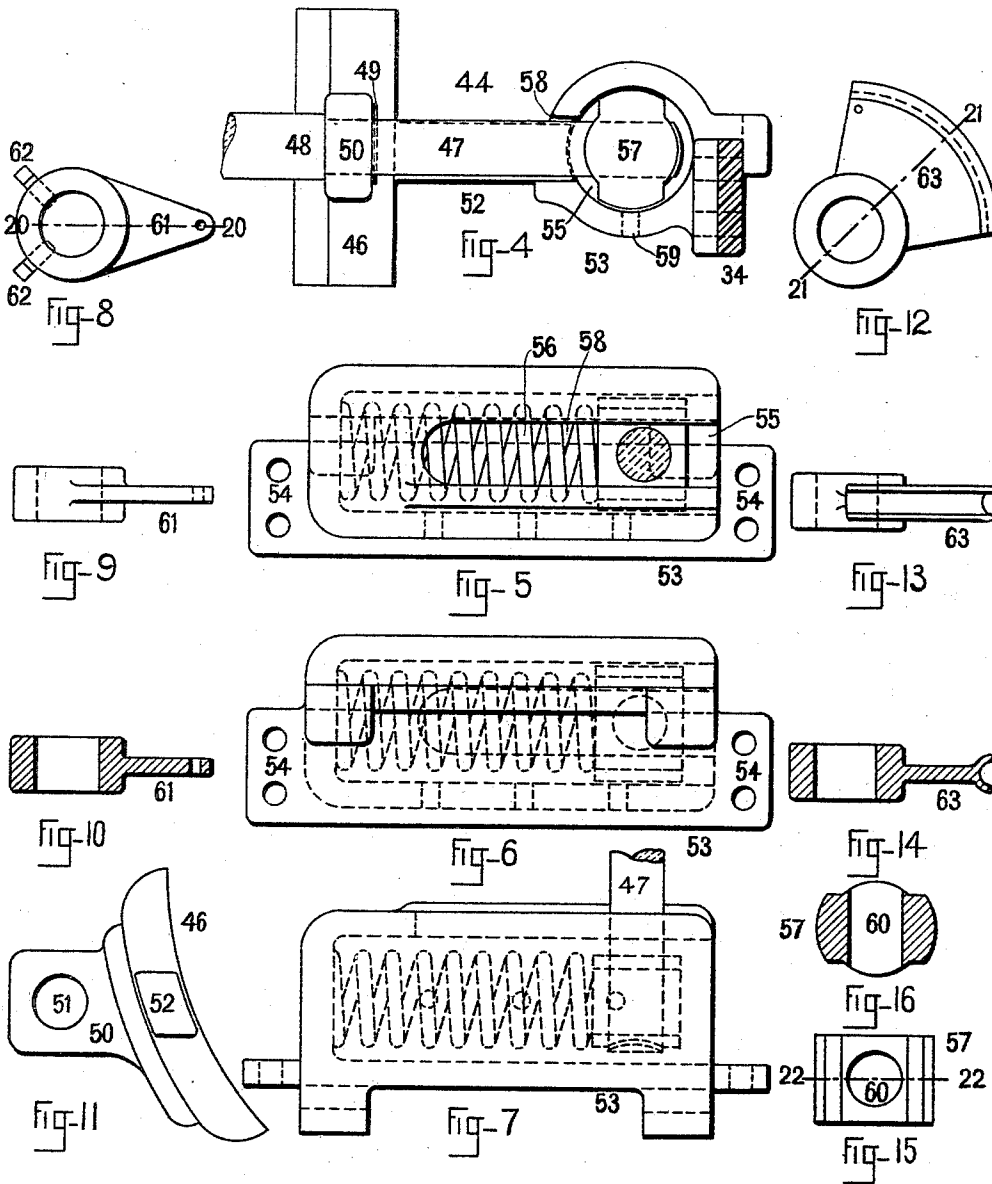

WITNESSES:

Walter L. Perry
J. Edward Porter

INVENTOR.

Thomas Tripp
BY
E. Frank Woodbury
ATTORNEY.

UNITED STATES PATENT OFFICE.

THOMAS TRIPP, OF AVON, MASSACHUSETTS.

CAR-BRAKE.

SPECIFICATION forming part of Letters Patent No. 450,761, dated April 21, 1891.

Application filed December 15, 1890. Serial No. 374,802. (No model.)

To all whom it may concern:

Be it known that I, THOMAS TRIPP, a citizen of the United States, residing at Avon, in the county of Norfolk and State of Massachusetts, have invented a new and useful Car-Brake, of which the following is a specification.

My invention relates to improvements in car-brakes of a class designed for use upon steam and street cars; and the objects of my improvements are, first, to produce a car-brake of great power and possessing in use great durability and safety; second, to accomplish these results by the use of as few separate simple pieces of mechanism as possible; third, to insure a quick-acting, powerful, durable, economical car-brake, which shall consist of few parts, so arranged as to obtain a maximum efficiency with a minimum amount of wear, thereby greatly reducing the injurious vibration of the brake-gear.

The drawings represent the car-brake as applied to a street-car.

Figure 1 represents in plan my device as applied to a street-car truck of a style especially adapted for electric-motor car purposes, the car-sills, the journal-box, tie-bars, and brake-beam supporter, and the brake-shaft connecting-rods being broken in order to show my device more clearly. Fig. 2 is an end elevation of Fig. 1. Fig. 3 is a side elevation of Fig. 1. Fig. 4 represents in elevation, on an enlarged scale, one brake-block, a portion of one brake-beam, the brake-beam sliding block, and brake-beam sliding block and spring-holder, the tie-bar being represented in section. Fig. 5 is a rear elevation of the beam sliding block and spring-holder, brake-beam sliding block, the brake-beam being represented in cross-section. In this view the brake-beam spring and sliding block are shown in their respective positions. Fig. 6 is a front elevation of Fig. 5. Fig. 7 represents Fig. 5 in plan. Fig. 8 represents the brake-beam crank in side elevation. Fig. 9 represents the brake-beam crank in front elevation, and Fig. 10 is a sectional view of Fig. 8 on line 20 20. Fig. 11 represents the brake-block in side elevation, on an enlarged scale. Fig. 12 represents in side elevation a modified form of brake-beam crank or quadrant,

and Fig. 13 is a front elevation of the same. Fig. 14 is a sectional view of Fig. 12 on line 21 21. Fig. 15 represents the brake-beam sliding block in side elevation, and Fig. 16 is a sectional view of the same on line 22 22.

The following parts are all of a class and style such as are in use upon several street-railways: sills 30, pedestals 31, journal-boxes 32, side journal-springs 33, journal-box tie-bars and brake-beam supporters 34, axles 35, wheels 36, brake-shaft connecting-rods 37, dash-guard 38, lower brake-shaft bearing 39, upper brake-shaft bearing 40, brake-shafts 41, brake-shaft cranks 42, and transverse floor-timbers 43.

The brake-beams 44 and 44' are alike, so are the secondary brake-rods 45 and 45' and the brake-blocks 46 and 46', except that they are rights and lefts, and they are constructed and connected as follows: Each brake-beam has its ends made alike, and each end, as shown upon an enlarged scale by Fig. 4, as 44, is provided with the reduced portion 47, upon which the brake-block 46 is loosely fitted. The brake-block is securely held in its position of oppositeness to the car-wheel upon the length of the brake-beam by means of the shoulder 48 and the cotter 49. This construction permits the free rotative movement of the brake-beam within the brake-blocks. One of the brake-blocks 46 is represented upon an enlarged scale by Figs. 4 and 11, and it is provided with the lug 50, having the hole 51, by means of which it is mounted upon the brake-beam. It is also provided with the side projection 52, of semi-rectangular section, which is so constructed as to permit its reciprocating movements within the brake-beam sliding block and spring-holder.

The brake-beam sliding block and spring-holders 53 and 53' are alike, except that they are rights and lefts. The brake-beam sliding block and spring-holder 53 is represented upon an enlarged scale by Figs. 4, 5, 6, and 7, and it is provided with the following: Holes 54, by the use of which it is bolted in its position upon the journal-box tie-bar and brake-beam supporter 34, spring and brake-beam sliding-block pocket 55, closed at one end and open at the other, designed to receive within it the brake-beam spiral spring 56 and brake-beam

sliding block 57, slot 58, designed to permit within it the reciprocating movements of the brake-beams, and apertures 59, adapted to permit (in use) the free escape of all dust, water, and ice which might (if permitted to remain) tend to clog the device.

The brake-beam sliding blocks 57 are alike, and one is represented upon an enlarged scale by Figs. 4, 15, and 16, and it is adapted to slide within the brake-beam sliding block and spring-holder. It is provided with hole 60, adapted to receive within it one end of the brake-beam, and in use it performs a double duty—first, as a cross-head or slide for the brake-beam; second, as a means of transmitting to the brake-beam the movements of the spiral spring.

The brake-beam cranks 61 and 61' are alike, and one is represented upon an enlarged scale by Figs. 8, 9, and 10, and it is designed to be secured to the brake-beam in any well-known manner, or, if it is desired to be adjustable upon brake-shaft, the set-screws 62 may be used. The quadrant-crank 63 (represented by Figs. 12, 13, and 14) may be substituted for the brake-beam crank, if it is desired, to obtain more perfect leverage upon the brake-beam.

In the usual manner each brake-shaft connecting-rod 37 has its forked end connected with the brake-beam crank and its chain end connected with the brake-shaft. This mechanism is designed to be operated in the usual way by turning the brake-shaft by means of the brake-shaft crank, thereby winding the chain end of the brake-shaft connecting-rod upon the brake-shaft.

Each end of each secondary brake-rod is provided with a chain and eyebolt, each eyebolt being securely fastened to its respective brake-beam. These secondary brake-rods may be made adjustable as to their length, if desired, by the employment of any well-known device, such as a common turn-buckle, which is represented on rod 45, Fig. 1. These rods, by reason of their chain ends, may be shortened by the winding of the chains upon the brake-beam when it is turned by the brake-shaft mechanism.

The tension of each brake-beam spiral spring may be adjusted by the use of shims or any well known device, such as a plate and set-screw, as represented by Fig. 1, as applied to one brake-beam sliding block and spring-holder.

All the parts having been constructed, arranged, and connected, as described, the operation of my device is as follows: The brakes being applied in the usual manner by the use of the brake-shaft crank by the operator, the power applied thereto is conveyed, first, to the brake-shaft, giving to it a rotary motion; second, the chain end of the brake-shaft connecting-rod, being thereby wound upon the brake-shaft, gives the brake-beam a rotary movement by reason of the brake-power being conveyed to the brake-beam by means

of the brake-shaft connecting-rod and brake-beam crank or lever. This rotary motion of the brake-beam forces the brake-beams toward each other, for the reason that they are connected together by the secondary brake-rods having chain ends, which are wound upon the brake-beam as it revolves, thereby lessening the distance between the brake-beams, and the brake-blocks being secured to the brake-beams, when the brake-beams are forced toward each other, are forced against the treads of the wheels and the resultant braking action ensues. The braking action is very quick and powerful, as the brake power is transmitted by the employment of few parts, which are so arranged that a maximum leverage may be obtained, reducing the speed of the motion applied to the handle of the brake-shaft crank to the slow motion of the brake-blocks toward the wheel-treads. The brake-blocks in operation move only in lines at right angles with the axis of the car-axes, for the reason that they are loosely fitted to the brake-beams, and at the same time they are guided by their semi-rectangular sections traveling within the slot of the brake-beam sliding block and spring-holder, and the reciprocating movements of the brake-beams are in the same lines, for the reason that to each end of a brake-beam is fitted a sliding block or cross-head, which travels within the sliding-block pocket of the brake-beam sliding block and spring-holder. The action of the brake-beam spiral springs (in operation when the brakes are released) is to force the brake-blocks clear of the tread of the wheels. This releasing action is accomplished by the springs pressing against the sliding blocks, which control the sliding or reciprocating movement of the brake-beam, to which are attached the brake-blocks.

It is obvious that the power to operate the brake-beams may be obtained from other sources than hand power, such as the air, hydraulic, and vacuum brake, which may be directly connected with the brake-beam cranks in any well-known manner.

As a matter of safety, two secondary brake-rods are used, as the breakage of either rod would not materially interfere with the operation of the brakes.

What I claim as new, and desire to secure by Letters Patent, is—

1. In a car-truck, in combination with operative mechanism, the brake-beams connected together by means of the secondary brake-rods having chain ends, each brake-beam being provided with a brake-beam crank or lever, and the brake-blocks, each of which is loosely fitted to the brake-beam and each being provided with a projection having a semi-rectangular section adapted to fit into and be guided by the slot in the brake-beam sliding block and spring-holder, substantially as described.

2. In a car-truck, the brake-beams connected together by means of flexible rods and

having loosely mounted thereon the sliding
brake-blocks, which are guided in their re-
ciprocating movements by the brake-beam
sliding block and spring-holders, which are
5 provided with spiral springs, in combination
with operative mechanism whereby in brak-
ing action the brake-blocks moving in hori-
zontal lines are pressed against the wheel-
treads by the rotary movements of the brake-
10 beams, and the releasing action is accom-
plished by the tension of the spiral springs,
which push the brake-blocks from the wheel-
treads, substantially as described.

3. In combination, the brake-beams 44 and
15 44', secondary brake-rods 45 and 45', brake-
blocks 46 and 46', brake-beam sliding block
and spring-holders 53 and 53', springs 56, and
brake-beam cranks 61 and 61', substantially
as described.

4. In combination with operative mechan- 20
ism, the brake-beams 44 and 44', secondary
brake-rods 45 and 45', brake-blocks 46 and
46', brake-beam sliding block and spring-
holders 53 and 53', each being provided with
25 a slot 58, adapted to receive and guide the
brake-block, a spring and brake-beam sliding-
block pocket 55, adapted to receive the spring
56 and the sliding block 57, substantially as
and for the purposes set forth.

In testimony whereof I have signed my name 30
to this specification in the presence of two
subscribing witnesses.

THOMAS TRIPP.

Witnesses:

CHARLES O. FARRAR,
WALTER L. PERRY.