



(51) International Patent Classification:
H05B 45/395 (2020.01)

(21) International Application Number:
PCT/TR2020/050045

(22) International Filing Date:
21 January 2020 (21.01.2020)

(25) Filing Language: English

(26) Publication Language: English

(30) Priority Data:
2019/00947 22 January 2019 (22.01.2019) TR

(71) Applicant: **TELETEK ELEKTRONİK SANAYİ VE TİCARET ANONİM ŞİRKETİ** [TR/TR]; Merkez Mah. Ayazma Cad. Demet İş Merkezi No:55 K:1 D:2, Kağıthane/İstanbul (TR).

(72) Inventor: **TEZOL, Atila**; Merkez Mah. Ayazma Cad. Demet İş Merkezi No:55 K:1 D:2, Kağıthane/İstanbul (TR).

(74) Agent: **OPTİMUM PATENT OFİSİ DANIŞMANLIK LTD. ŞTİ.**; 19 Mayıs Mah. Halaskargazi Cad. No:220 K:9 D:16, 34360 Şişli/İstanbul (TR).

(81) Designated States (unless otherwise indicated, for every kind of national protection available): AE, AG, AL, AM, AO, AT, AU, AZ, BA, BB, BG, BH, BN, BR, BW, BY, BZ, CA, CH, CL, CN, CO, CR, CU, CZ, DE, DJ, DK, DM, DO,

DZ, EC, EE, EG, ES, FI, GB, GD, GE, GH, GM, GT, HN, HR, HU, ID, IL, IN, IR, IS, JO, JP, KE, KG, KH, KN, KP, KR, KW, KZ, LA, LC, LK, LR, LS, LU, LY, MA, MD, ME, MG, MK, MN, MW, MX, MY, MZ, NA, NG, NI, NO, NZ, OM, PA, PE, PG, PH, PL, PT, QA, RO, RS, RU, RW, SA, SC, SD, SE, SG, SK, SL, ST, SV, SY, TH, TJ, TM, TN, TR, TT, TZ, UA, UG, US, UZ, VC, VN, WS, ZA, ZM, ZW.

(84) Designated States (unless otherwise indicated, for every kind of regional protection available): ARIPO (BW, GH, GM, KE, LR, LS, MW, MZ, NA, RW, SD, SL, ST, SZ, TZ, UG, ZM, ZW), Eurasian (AM, AZ, BY, KG, KZ, RU, TJ, TM), European (AL, AT, BE, BG, CH, CY, CZ, DE, DK, EE, ES, FI, FR, GB, GR, HR, HU, IE, IS, IT, LT, LU, LV, MC, MK, MT, NL, NO, PL, PT, RO, RS, SE, SI, SK, SM, TR), OAPI (BF, BJ, CF, CG, CI, CM, GA, GN, GQ, GW, KM, ML, MR, NE, SN, TD, TG).

Published:

- with international search report (Art. 21(3))
- before the expiration of the time limit for amending the claims and to be republished in the event of receipt of amendments (Rule 48.2(h))
- in black and white; the international application as filed contained color or greyscale and is available for download from PATENTSCOPE

(54) Title: CURRENT CONTROL CIRCUIT

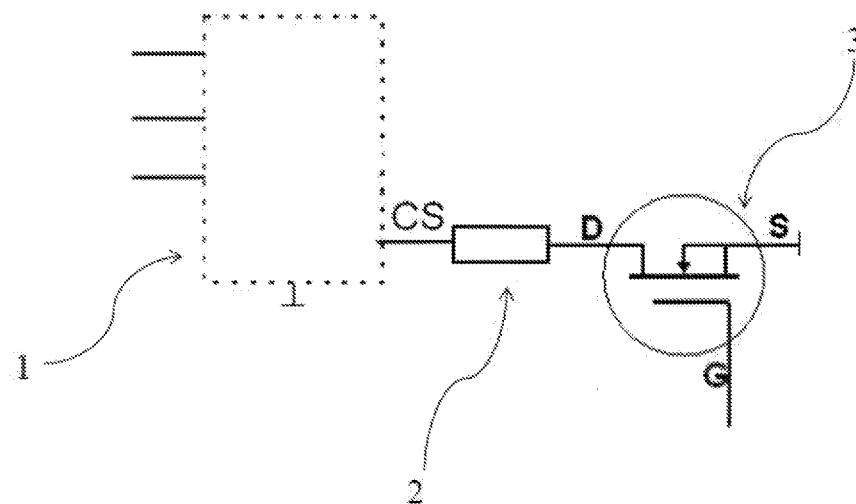

FIGURE 1

(57) Abstract: The invention relates to led lighting, dimming, easy replacement of power current in small/medium power electronics.



CURRENT CONTROL CIRCUIT

5 The invention is related to led (light emitting diode) lighting, dimming, easy replacement of power current in small/medium power electronics.

The development of electronics continues very rapidly thanks to the development of semiconductor technology, the development of electronics in our daily lives facilitates our lives in many areas.

10 **Prior Art**

The current control is carried out with constant resistors in the drivers that give a constant current like the led driver. Because resistors are a physical parts, it is not possible to change their value electronically. The change of the digital current uses DALI (Digital Adressable Lighting Interface) system, which is more complex and cost effective than the invention.

15 In the patent document titled 'Current controlled led driver', published in 2010/05477, which is included in the prior art, the current at the output of the driver is constant and the electronic elements required for the creation of the drive are excessive, which creates a problem in terms of cost.

20 In the patent document titled 'Ac micro led driver chip' in issue no. 2015/02165, also with the prior art, the current value cannot be excluded from the predetermined value. Since the current value is determined by the resistors on it, it must be specially designed for the led and device to operate. This makes the invention to be unavailable in devices of different energy spectrum.

Purpose Of Invention

25 This invention allows the drivers to adjust the desired current value from the output section and make PF (power factor) correction easier. In addition, drive currents can be produced in the desired form (sine, trapezoidal, square...). Especially small power sources that provide compatible energy to the network make it easier to produce sine wave voltage.

Brief Explanation of The Invention

The invention relates to led lighting, dimming, easy change of power current in small/medium power electronics, PF regulation and the current control circuit which transfers the desired current value to the device. It is characterized in that it has at least one mosfet (Metal Oxide Semiconductor Field Effect Transistor) to provide current control and/or to check the permeability of the current, at least one resistance for the stabilization of current to the drive and the PF regulation, and at least one drive which enables the regulation of PF and the connection of the current controlled current to the device.

10 Explanation Of Figures

Figure 1: Dimming scheme

Figure 2: PF correction scheme

Figure 3: Dimming + PF correction scheme

15 Explanation Of References

NO.	Name of Part
1	Driver
2	Resistance
3	Mosfet

20

Decription of the Invention

The dimming scheme is given in Figure 1, which consists of driver (1), resistor (2) and mosfet (3). In one example use of the circuit; if the voltage to mosfet (3) is '0', it is current-proof and closed. RDS (resistance between drain-source) is almost ∞ (the current is too large to flow). If the voltage to mosfet (3) is '1', the mosfet (3) lets the flow of the current, it is open. RDS is in

the minimum value here. If the voltage to mosfet (3) is between "0-1", the RDS on mosfet (3) is variable and it will be possible to change between 10 milliohm and ∞ ohm according to mosfet (3) type. In this way, current control will be possible since the total resistance will be $R(1)+RDS$. In sampling, resistance on Scheme (1) has been used in literature as resistance is expressed with 'R'.

Figure 2 shows the PF correction scheme, which consists of driver (1), resistor (2) and mosfet (3). Another exemplary use of the circuit makes it possible to fully utilize all the energy of the device that will use the electrical energy output from the driver (1), that is, to check the current value of PF (power factor) to be 1.0. In order to keep the PF value to the desired extent and to make sufficient amount of current to reach the device, and the amount of current required to pass through the mosfet (3) is adjusted according to the value range. If the PF value is close to 1.0, thus saving energy since the energy consumption of the device is in the correct proportion.

Dimming + PF correction scheme is given in Figure 3, this scheme consists of driver (1), resistor (2) and mosfet (3). In another exemplary use of the circuit, it can be used by connecting the connection part with "S" (source) leg of the mosfet (3) in the dimming circuit scheme and the driver (1) in the PF correction circuit diagram. In this way, current control can be controlled more precisely.

Mosfet transistors are destroyed at small 'gate' voltages due to excessive heat, as much current will pass through the transistor if the 'drain-source' voltage is high. In this patent application, the 'drain-source' voltage is equal to the Sens control voltage (UCS) voltage, and because the UCS voltages are small (0.1 to 0.8 volts) due to the structures of the drives, the mosfet is naturally protected and these voltages are not sufficient to destroy the mosfet transistor if selected appropriately.

The invention allows easy dimming and energy saving by bringing PF closer to 1.0.

CLAIMS

1- A current control circuit which transfers a desired current value to a device like led lighting, dimming, easy change of power current in small / medium power electronics, PF
5 regulation, and it is characterized by comprising;

-at least one mosfet (3) to provide current control and/or control the current's permeability,

- at least one resistance (1) for stabilization of current to a driver (1) and PF regulation.

2- It is a current control circuit according to claim 1, and it is characterized by comprising
10 where mosfet (3) and resistance are connected to each other in series in the current control
circuit.

3-The current control circuit in claim 1 and it is characterized by comprising

- at least one driver (1) that ensures the PF regulation and connection of the current whose
current control is made to the device.

4. The current control circuit of claim 1, characterized by comprising that the voltage passing
15 over the mosfet (3) when in operation converges to the value of "0" but is not "0".

20

25

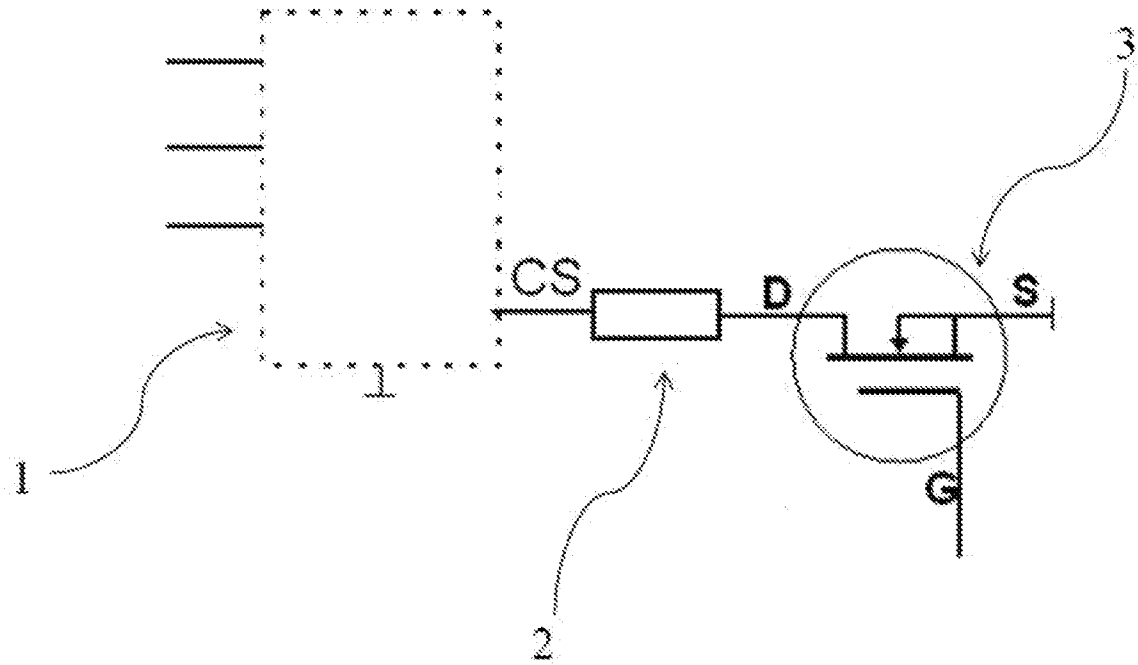

FIGURE 1

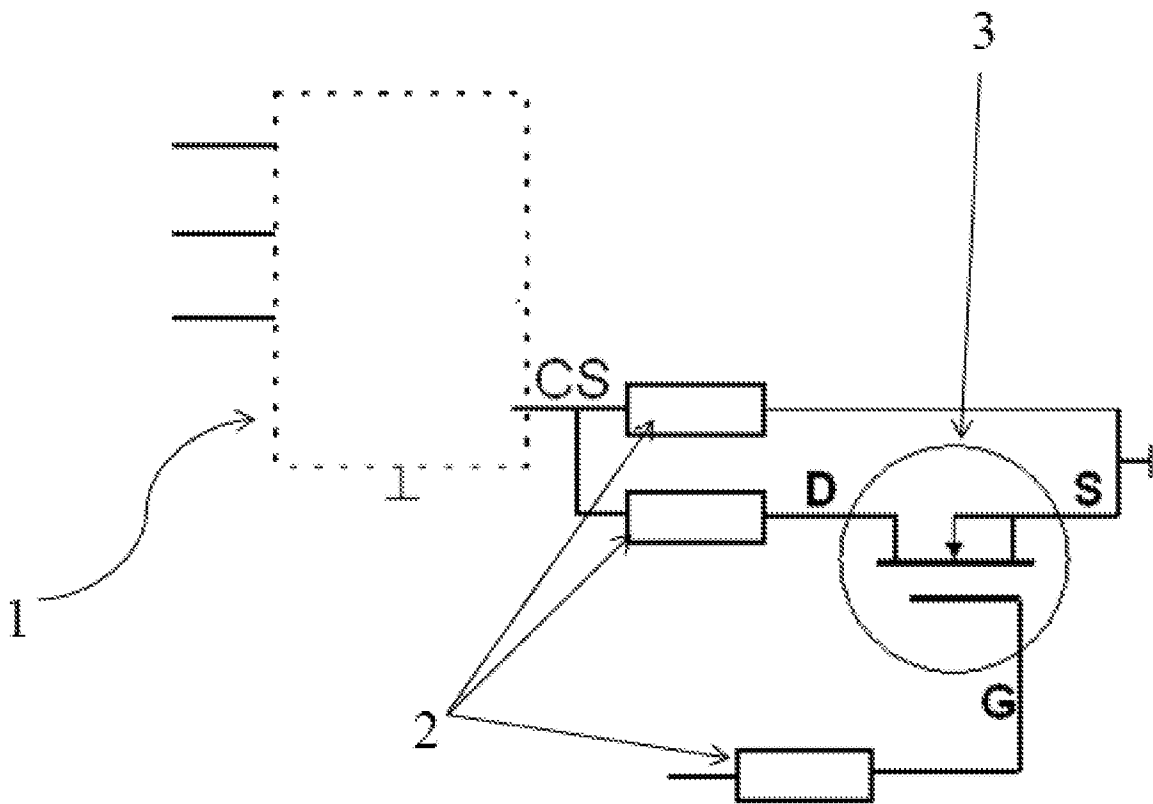

FIGURE 2

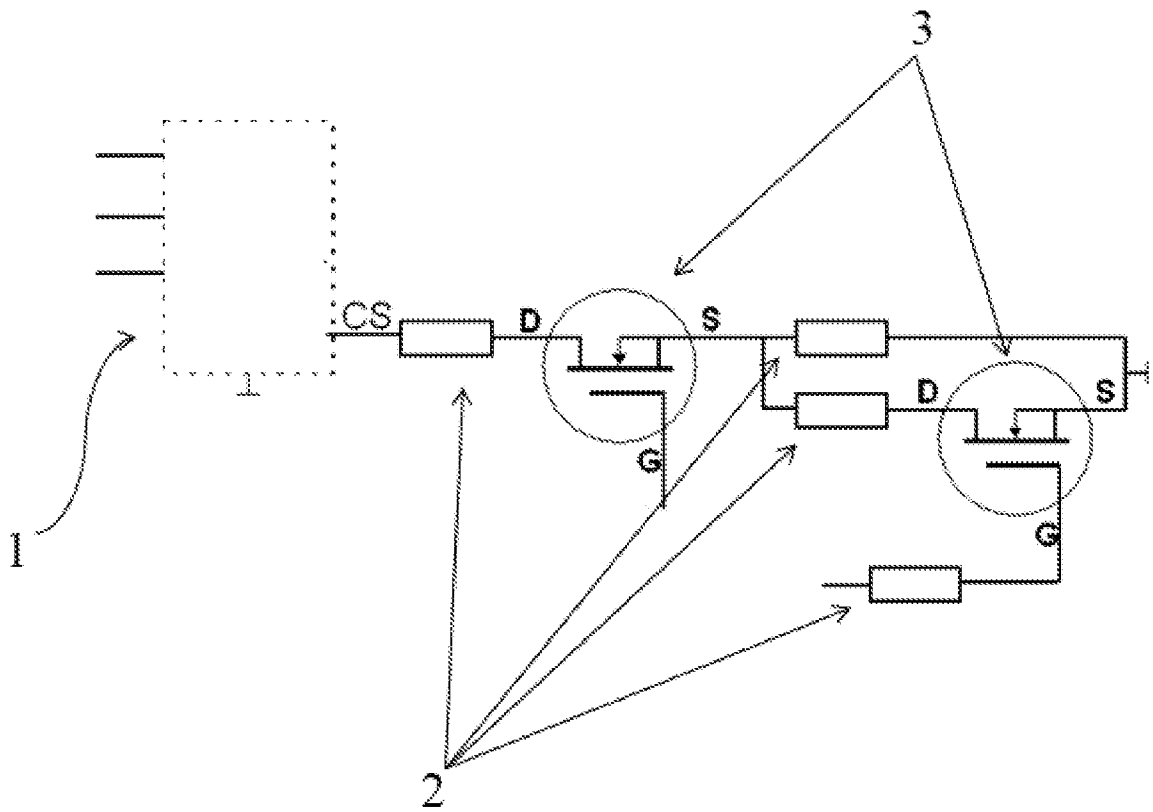

FIGURE 3

INTERNATIONAL SEARCH REPORT

International application No
PCT/TR2020/050045

A. CLASSIFICATION OF SUBJECT MATTER
INV. H05B45/395
ADD.

According to International Patent Classification (IPC) or to both national classification and IPC

B. FIELDS SEARCHED
Minimum documentation searched (classification system followed by classification symbols)
H05B

Documentation searched other than minimum documentation to the extent that such documents are included in the fields searched

Electronic data base consulted during the international search (name of data base and, where practicable, search terms used)
EPO-Internal, WPI Data

C. DOCUMENTS CONSIDERED TO BE RELEVANT

Category*	Citation of document, with indication, where appropriate, of the relevant passages	Relevant to claim No.
X	US 2012/161650 A1 (LIANG TSORNG-JUU [TW] ET AL) 28 June 2012 (2012-06-28) pages 1-3; figures 1, 5 -----	1-4
X	EP 2 563 094 A2 (O2MICRO INC [US]) 27 February 2013 (2013-02-27) pages 3-6; figure 2 -----	1-4
X	US 2013/099686 A1 (GE LIANG AN [CN] ET AL) 25 April 2013 (2013-04-25) paragraphs [0065] - [0073]; figure 10 -----	1-4

Further documents are listed in the continuation of Box C.

See patent family annex.

* Special categories of cited documents :

- "A" document defining the general state of the art which is not considered to be of particular relevance
- "E" earlier application or patent but published on or after the international filing date
- "L" document which may throw doubts on priority claim(s) or which is cited to establish the publication date of another citation or other special reason (as specified)
- "O" document referring to an oral disclosure, use, exhibition or other means
- "P" document published prior to the international filing date but later than the priority date claimed

- "T" later document published after the international filing date or priority date and not in conflict with the application but cited to understand the principle or theory underlying the invention
- "X" document of particular relevance; the claimed invention cannot be considered novel or cannot be considered to involve an inventive step when the document is taken alone
- "Y" document of particular relevance; the claimed invention cannot be considered to involve an inventive step when the document is combined with one or more other such documents, such combination being obvious to a person skilled in the art
- "&" document member of the same patent family

Date of the actual completion of the international search 13 May 2020	Date of mailing of the international search report 26/05/2020
--	--

Name and mailing address of the ISA/ European Patent Office, P.B. 5818 Patentlaan 2 NL - 2280 HV Rijswijk Tel. (+31-70) 340-2040, Fax: (+31-70) 340-3016	Authorized officer Morrish, Ian
--	--

INTERNATIONAL SEARCH REPORT

Information on patent family members

International application No PCT/TR2020/050045

Patent document cited in search report	Publication date	Patent family member(s)	Publication date
US 2012161650	A1	28-06-2012	CN 102612204 A
			TW 201228456 A
			US 2012161650 A1

EP 2563094	A2	27-02-2013	BR 102012021553 A2
			CN 102740557 A
			EP 2563094 A2
			JP 2013045768 A
			TW 201340776 A
			US 2013069546 A1

US 2013099686	A1	25-04-2013	CN 102300355 A
			US 2013099686 A1
			WO 2011160380 A1
