



US 20080037784A1

(19) **United States**

(12) **Patent Application Publication**  
**Corcoran et al.**

(10) **Pub. No.: US 2008/0037784 A1**

(43) **Pub. Date: Feb. 14, 2008**

(54) **POWER LINE COMMUNICATION DEVICE  
AND METHOD OF USING THE SAME**

**Publication Classification**

(76) Inventors: **Kevin F. Corcoran**, Middletown, MD  
(US); **James Douglas Mollenkopf**,  
Fairfax, VA (US)

(51) **Int. Cl.**  
**H04L 9/00** (2006.01)  
(52) **U.S. Cl.** ..... **380/255**

Correspondence Address:  
**CAPITAL LEGAL GROUP, LLC**  
**1100 River Bay Road**  
**Annapolis, MD 21409 (US)**

(57) **ABSTRACT**

The repeater of the present invention communicates data signals over power lines. The repeater of one embodiment includes at least one modem that receives a data packet and attempts to decrypt the data packet with a first and/or second encryption key. If the packet is successfully decrypted using the first encryption key, the packet is encrypted using the second encryption and transmitted over the power line. If the packet is successfully decrypted using the second encryption key, the packet is encrypted using the first encryption and transmitted over the power line.

(21) Appl. No.: **11/873,208**

(22) Filed: **Oct. 16, 2007**

**Related U.S. Application Data**

(63) Continuation of application No. 10/434,024, filed on May 8, 2003, now Pat. No. 7,308,103.

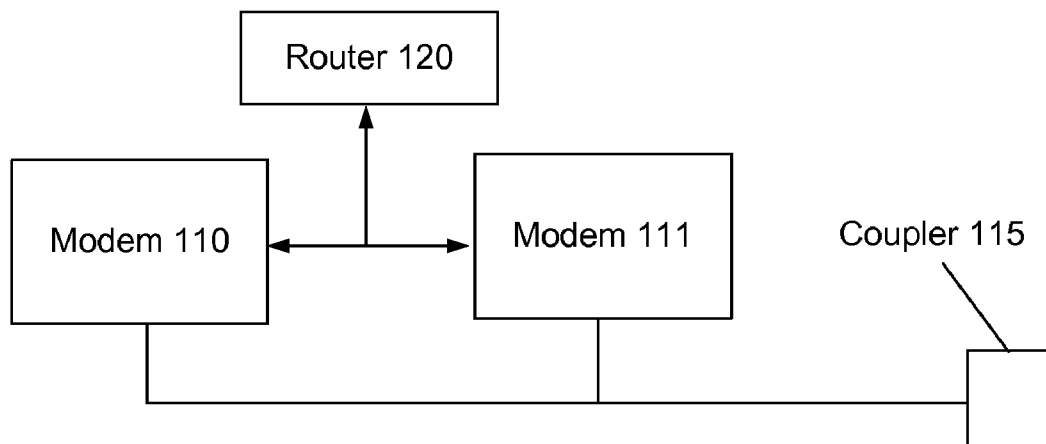

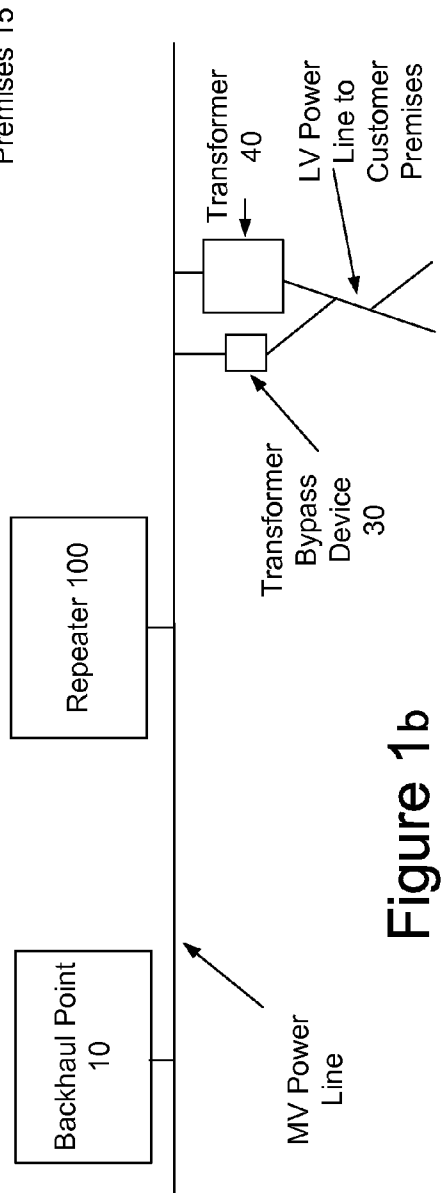
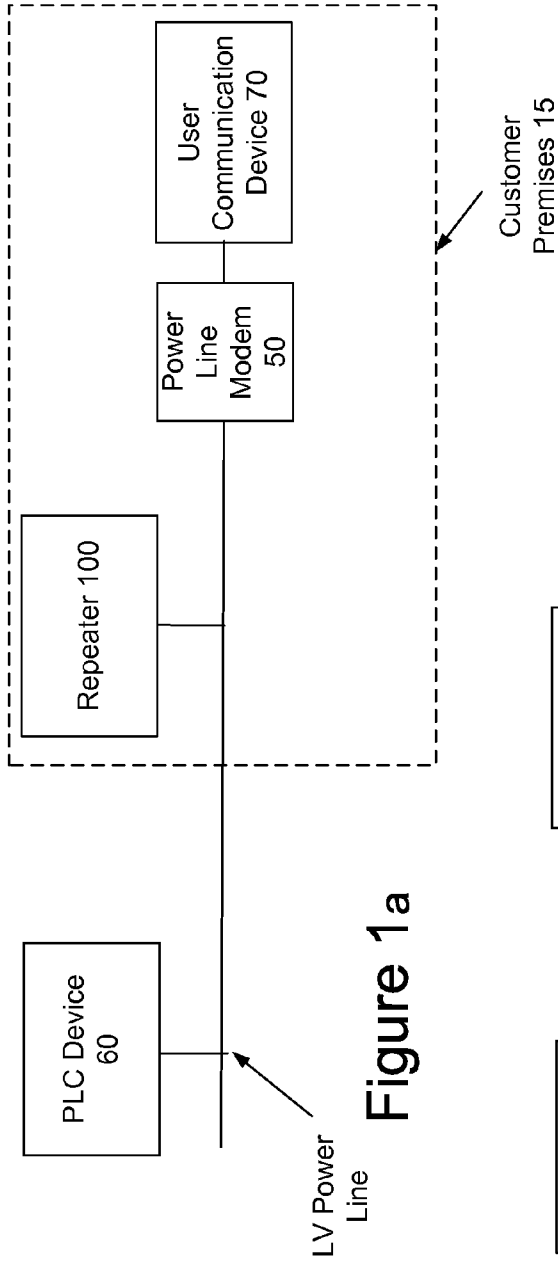

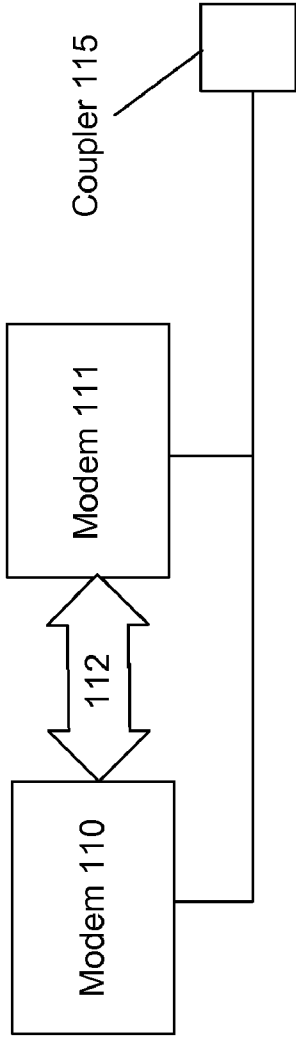

Figure 2

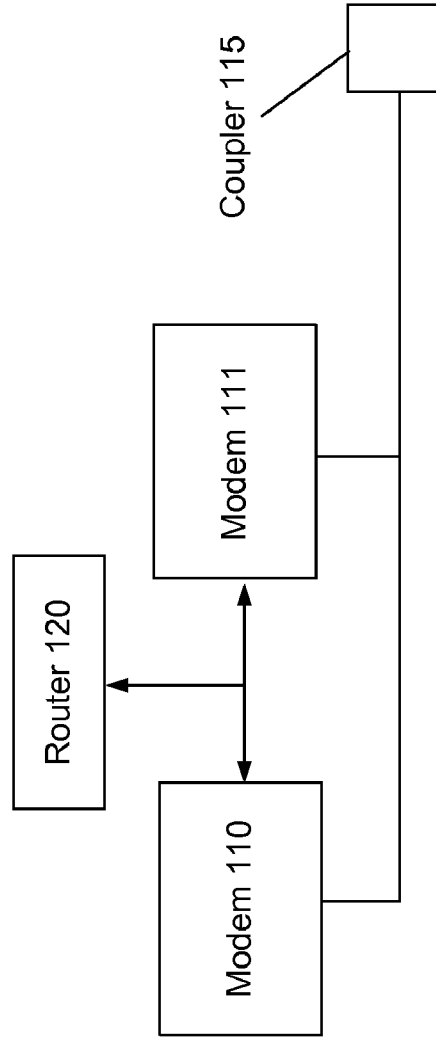
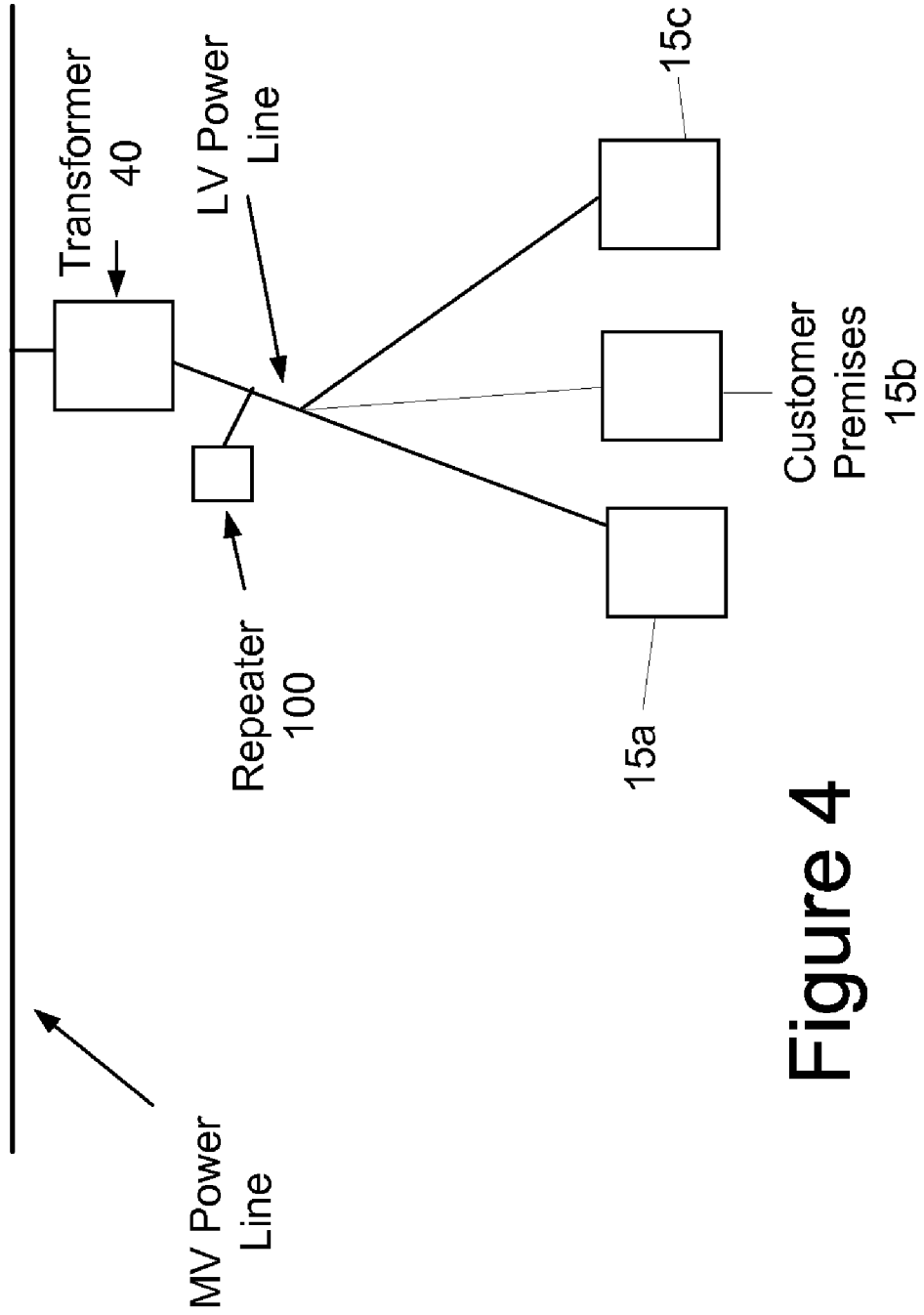

Figure 3



**Figure 4**

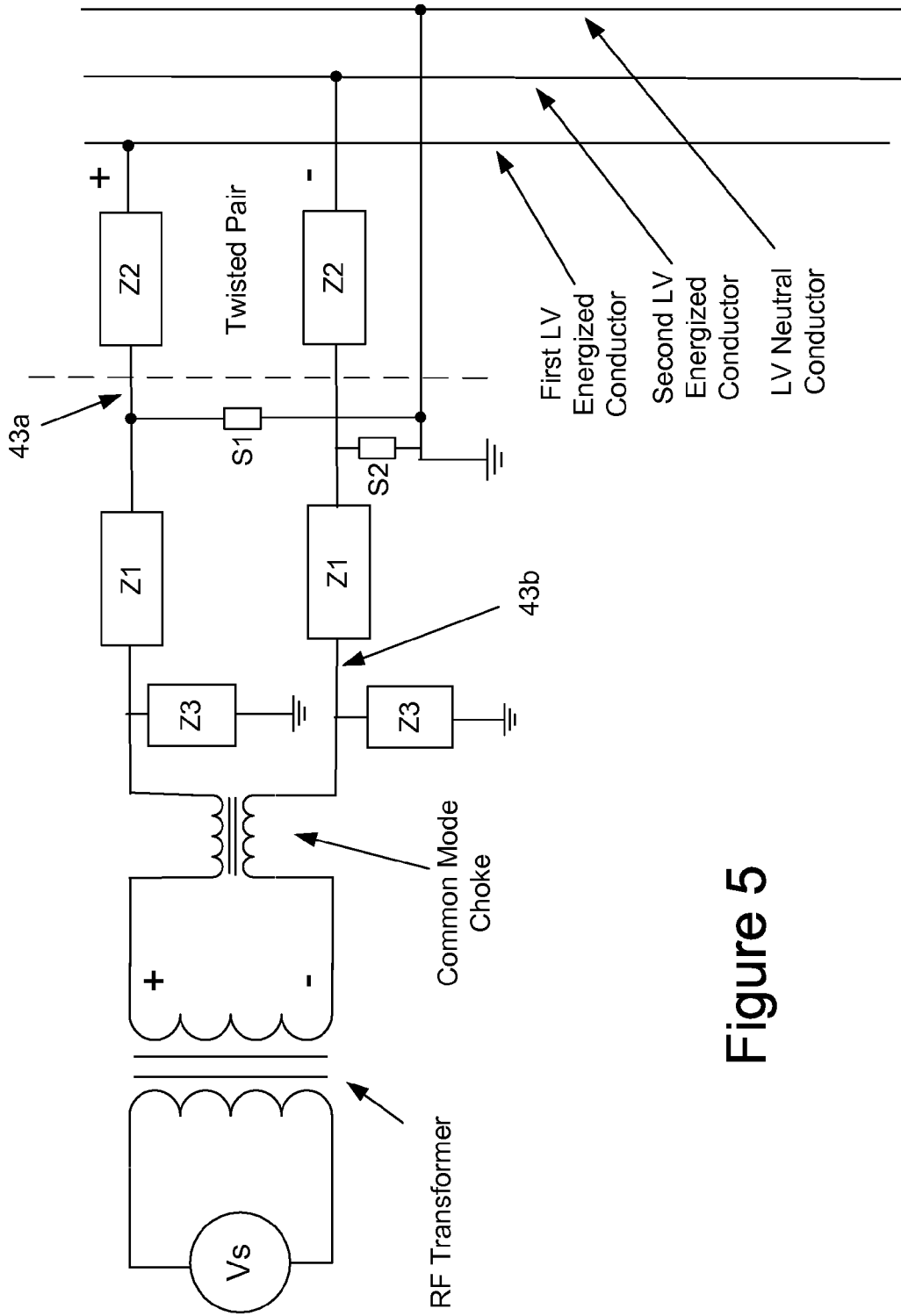

Figure 5

**POWER LINE COMMUNICATION DEVICE AND METHOD OF USING THE SAME**

**CROSS-REFERENCE TO RELATED APPLICATIONS**

[0001] This application is a continuation of, and claims priority to, U.S. patent application Ser. No. 10/434,024 filed May 8, 2003, which is incorporated herein by reference in its entirety.

**FIELD OF THE INVENTION**

[0002] The present invention relates, generally, to power line communication devices and in particular, to a communication device for repeating data signals on power lines.

**BACKGROUND OF THE INVENTION**

[0003] Well-established power distribution systems exist throughout most of the United States, and other countries, that provide power to customers via power lines. With some modification, the infrastructure of the existing power distribution systems can be used to provide data communication in addition to power delivery, thereby forming a power line communication system (PLCS). In other words, existing power lines that already have been run to many homes and offices can be used to carry data signals to and from the homes and offices. These data signals are communicated on and off the power lines at various points in the power distribution communication system, such as, for example, near homes, offices, Internet service providers, and the like.

[0004] While the concept may sound simple, there are many challenges to overcome in order to use power lines for data communication. Power distribution systems include numerous sections, which transmit power at different voltages. The transition from one section to another typically is accomplished with a transformer. The sections of the power line distribution system that are connected to the customers typically are low voltage (LV) sections having a voltage between 100 volts and 240 volts, depending on the system. In the United States, the low voltage section typically is about 120 volts (120V). The sections of the power distribution system that provide the power to the low voltage sections are referred to as the medium voltage (MV) sections. The voltage of the MV section is in the range of 1,000 Volts to 100,000 volts and typically 8.66 kilo volts (kV) to neutral (15 kV between phase conductors). The transition from the MV section to the LV section of the power distribution system typically is accomplished with a distribution transformer, which converts the higher voltage of the MV section to the lower voltage of the LV section.

[0005] Power system transformers are one obstacle to using MV or LV power distribution lines for data communication. Transformers designed for conversion of voltages at power frequencies (i.e. 50 or 60 Hz) present complex and often undesirable series and shunt impedances that can be detrimental to data signal frequencies useful for data communication. As such, power distribution communication systems face the challenge of passing the data signals around (or sometimes through) the distribution transformers.

[0006] Many power lines, including both LV (external and the internal customer premise power line wiring) and MV power lines, provide a high impedance communication

channel for high frequency data signals thereby significantly attenuating data signals. In addition, power lines may provide a very noisy communication channel and such noise is often sporadic and unpredictable. Thus, due to the limited power that may be used to transmit data signals on power lines (for example, due to Federal Communication Commission (FCC) regulations regarding RF emissions), high frequency data signals will only propagate a finite distance that in some instances may not be far enough from the transmitting source to be reliably received by the intended communication device.

[0007] Thus, there is a need for a power line communication device to extend the range of communications of a power line communication (PLC) device. Such a device should be designed to facilitate bi-directional communication. In addition, the device (or repeater as sometimes referred to herein) should enable the transmission and reception of broadband radio frequency (RF) signals used for data transmission over high voltage (HV), MV and LV power lines, including the internal customer premise wiring. Finally, it is desirable to design such a repeater to be installed without the need to disconnect power from the power lines.

**SUMMARY OF THE INVENTION**

[0008] The device of the present invention communicates data signals over power lines. The repeater of one embodiment comprises at least one modem that receives a data packet and attempts to decrypt the data packet with a first and/or second encryption key. If the packet is successfully decrypted using the first encryption key, the packet is encrypted using the second encryption and transmitted over the power line. If the packet is successfully decrypted using the second encryption key, the packet is encrypted using the first encryption and transmitted over the power line. The use of multiple encryption keys creates multiple logical networks.

[0009] Further features and advantages of the present invention, as well as the structure and operation of various embodiments of the present invention, are described in detail below with reference to the accompanying drawings.

**BRIEF DESCRIPTION OF THE DRAWINGS**

[0010] The accompanying drawings, which are incorporated herein and form part of the specification, illustrate various embodiments of the present invention and, together with the description, further serve to explain the principles of the invention and to enable a person skilled in the pertinent art to make and use the invention. In the drawings, like reference numbers indicate identical or functionally similar elements.

[0011] A more complete appreciation of the invention and many of the attendant advantages thereof will be readily obtained as the same becomes better understood by reference to the following detailed description when considered in connection with the accompanying drawings, wherein:

[0012] FIG. 1a is a schematic of an example PLCS employing an example embodiment of a communication device according to the present invention;

[0013] FIG. 1b is a schematic of another example PLCS employing an example embodiment of a communication device according to the present invention;

[0014] FIG. 2 is a schematic of an example embodiment of a communication device according to the present invention;

[0015] FIG. 3 is a schematic of another example embodiment of a communication device according to the present invention;

[0016] FIG. 4 is a schematic of another example embodiment PLCS employing an example embodiment of a communication device according to the present invention; and

[0017] FIG. 5 is a schematic of a portion of an example embodiment of a communication device according to the present invention.

#### DETAILED DESCRIPTION OF THE PREFERRED EMBODIMENTS

[0018] In the following description, for purposes of explanation and not limitation, specific details are set forth, such as particular networks, communication systems, computers, terminals, devices, components, techniques, data and network protocols, software products and systems, enterprise applications, operating systems, development interfaces, hardware, etc. in order to provide a thorough understanding of the present invention.

[0019] However, it will be apparent to one skilled in the art that the present invention may be practiced in other embodiments that depart from these specific details. Detailed descriptions of well-known networks, communication systems, computers, terminals, devices, components, techniques, data and network protocols, software products and systems, operating systems, development interfaces, and hardware are omitted so as not to obscure the description of the present invention.

#### I. System Architecture and General Design Concepts

[0020] The repeater of the present invention may be used to communicate data over LV, MV, or HV power lines and to communicate with any PLC device such as a transformer bypass device, a backhaul point, another repeater, a power line modem or any other device communicatively coupled to the power line. The present invention may be used to communicate data signals over both underground and overhead power lines. In addition, the present invention also may be communicatively coupled to LV power lines inside the customer premises (e.g., at a wall socket) (an indoor repeater) or external to the customer premises (an outdoor repeater). The outdoor repeater may be installed on the exterior of, or adjacent to, the customer premises or may be installed near, or adjacent to, the distribution transformer serving the customer premises (e.g., on a utility pole or inside a transformer enclosure). As will be discussed in detail below, the repeater may provide communications for a plurality of user devices that may be located in different (or the same) customer premises.

[0021] FIG. 1a is a schematic of an example embodiment of a PLC system employing a repeater 100 according to the invention that is designed to repeat data signals over the LV power lines. The repeater 100 in this topology is positioned inside the customer premises and may be plugged into a wall socket that preferably, although not necessarily, is near the breaker box so that the repeater 100 is near the location at which the LV power line enters the customer premises and where the data signals are strong enough to be reliably

received by the repeater 100. Alternately, the repeater 100 may be communicatively coupled to the LV power line at the breaker box (e.g., inside the box) or coupled to the external LV power lines on the outside of the customer premises.

[0022] As shown in FIG. 1a, the topology includes a user communication device 70 connected to a power line modem 50. The user communication device 70 may be any device capable of supplying data for transmission (or for receiving such data) including, but not limited to a computer, a telephone, a telephone answering machine, a fax, a digital cable box (e.g., for processing digital audio and video, which may then be supplied to a conventional television and for transmitting requests for video programming), a video game, a stereo, a videophone, a television (which may be a digital television), a video recording device, a home network device, a utility meter, a home security system, or other device.

[0023] The user communication device 70 is communicatively coupled to the power line modem 50 (sometimes known as a power line interface device), which is well-known in the art. In some instances, the power line modem 50 may be integral to the user device. The power line modem 50 serves as an interface for user devices to access the PLC system. The power line modem 50 can have a variety of interfaces for user communication devices data. For example, a power line modem 50 can include a RJ-11 Plain Old Telephone Service (POTS) connector, an RS-232 connector, a USB connector, a 10 Base-T connector, RJ-45 connector, coaxial connector, optical fiber connector, and the like. In this manner, a customer can connect a variety of user devices to the PLCS. Further, multiple power line modems can be plugged into power outlets throughout the customer premises 15, with each power line modem 50 communicating over the same wiring internal to the customer premises 15.

[0024] Data received by the repeater 100 from the PLC device 60, which as discussed above may be a transformer bypass device, another repeater 100, a communication interface device, or other device, may be repeated for reception by the power line modem 50 and subsequent reception by the user communication device 70. Data received by the repeater from the power line modem 50 (e.g., originating from the user communication device 70) may be repeated for reception by the PLC device 60.

[0025] FIG. 1b is a schematic of another example PLCS employing the invention. In this embodiment, the repeater 100 is communicatively coupled to the MV power line and provides bi-directional communications between a backhaul point 10 and a transformer bypass device 30. It will be evident to those skilled in the art that various embodiments of the present invention may be used to provide communications between any two or more PLC devices.

[0026] FIG. 2 illustrates an example embodiment of the present invention, which is comprised of a first modem 110 and a second modem 111 that are communicatively coupled to each other via communication path 112, which may be an Ethernet bus or other form of communication interface. In addition, both modems 110 and 111 are communicatively coupled to the power line via coupler 115. In this embodiment, coupler 115 may be a conventional three prong wall plug. Although not shown in FIG. 2, this embodiment also includes a power supply that receives power from the LV

power line to which the repeater **100** is coupled (and through which the repeater **100** provides communications) and supplies power to the modems.

[0027] The modems **110** and **111** may include a modulator, demodulator, an encryption module and a decryption module. In addition, the modems also may include one or more additional functional submodules such as an amplifier, one or more filters, an Analog-to-Digital Converter (ADC), Digital-to-Analog Converter (DAC), a memory, source encoder/decoder, an error encoder/decoder, a channel encoder/decoder, a MAC (Media Access Control) processor. These additional functional submodules may be omitted in some embodiments, may be integrated into a modem integrated circuit (chip or chip set), or may be peripheral to a modem chip. In the present example embodiment, the modems **110** and **111** are formed, at least in part, by part number INT51X1, which is an integrated power line transceiver circuit incorporating most of the above-identified submodules, and which is manufactured by Intellon, Inc. of Ocala, Fla.

[0028] The incoming power line data signal from the coupler **115** is supplied to each modem where the RF data signal is extracted from the power signal (e.g., by a high pass filter) and supplied to the ADC of each modem, which converts the incoming RF analog signal to a digital signal. The digital signal is then demodulated. Each modem may then attempt to decrypt the packet. After the decryption algorithm is executed, the modem will perform a validation procedure. Validation procedures are well known in the art and used to determine the validity of the decrypted packet and may be comprised of a cyclic redundancy check (CRC), a check sum validation, or any other such procedure.

[0029] If the validation procedure fails, the packet is discarded (ignored). If the validation procedure passes, the modem may provide source decoding, error decoding, channel decoding, and/or MAC processing, if appropriate, all of which are known in the art and, therefore, not explained in detail here.

[0030] In this example embodiment of the invention, the first modem **110** is assigned a first encryption key and the second modem **111** is assigned a second encryption key that is different from the first encryption key. The encryption key is stored in the memory of the modem and used to encrypt and decrypt power line data signals.

[0031] Packets transmitted over the LV power line by and to the PLC device **60** are encrypted (and decrypted) using the first encryption key. Packets transmitted by and to the power line modem **50** are encrypted (and decrypted) using the second encryption key.

[0032] During operation, the PLC device **60**, which may be a transformer bypass device, a backhaul point, another repeater **100**, a communication interface device (as described below), or other device, may receive the data packet (e.g., from a remote source), encrypt the data packet using the first encryption key, and transmit the data packet on the power line (which may include error coding, channel coding, modulating the packet, converting the digital signal to analog, and other process steps associated with transmitting). Modem **110** and modem **111** receive the data packet, demodulate the data packet and attempt to decrypt the packet. However, only the first modem **110** successfully

decrypts the data packet because the first modem **110** has the correct encryption key for decrypting the packet. Consequently, the validation procedure of the first modem **110** passes and the validation procedure of the second modem **111** fails (because the second modem does not have the correct key for decryption). The second modem therefore discards the packet.

[0033] The first modem performs the additional processing of the packet as is necessary, which may comprise source decoding, error decoding, channel decoding, and/or MAC processing. The packet is then transmitted via data path **112** to the second modem **111**. The second modem may provide MAC processing channel encoding, source encoding, error encoding, and encryption. The encryption by the second modem **111** is performed using the second encryption key. The data is then modulated and provided to the DAC to convert the digital data to an analog signal for transmission through the coupler **115** onto the power line.

[0034] Both the PLC device **60** and the power line modem **50** may receive the packet transmitted by the repeater **100**. In addition, the first modem **110** may receive the packet as well. However, the decryption of the data packet by PLC device **60** (and first modem **110**) will result in a packet that fails to pass the validation procedure because the packet has been encrypted using the second encryption key (while the PLC device and first modem **110** use the first encryption key to decrypt the packet). The power line modem **50** will successfully decrypt the packet and, therefore, may pass the data to the user communication device.

[0035] Transmissions from the power line modem **50** will likewise be decrypted by the second modem **111** (using the second encryption key) and not by the first modem **110**. The second modem **111** will transmit the decrypted data packet to the first modem **110**, which will encrypt the data packet using the first encryption key, and subsequently transmit the data packet over the power line. The transmitted data packet may be received by the PLC device **60**, the power line modem **50**, and perhaps the second modem **111**. The power line modem **50** (and second modem **111**) will attempt to decrypt the packet using the second encryption key and fail the validation procedure. The PLC device **60** will successfully decrypt the packet and, if appropriate, transmit the packet through the PLC network or other network.

[0036] This embodiment of the invention may receive and repeat every data packet that the device successfully decrypts. Alternately, the invention may be configured to repeat only select data packets such as those successfully decrypted and having the correct MAC address (or IP address). Thus, different repeaters in different customer premises may use the same set of encryption keys, but have different MAC addresses (or IP addresses) so that the repeater having the MAC address (or IP address) that corresponds to the destination address of the packet is the only repeater that repeats the data packet. Each modem may have its own MAC address (and/or IP address stored in memory).

[0037] As shown in FIG. *1b*, another example embodiment of the repeater **100** for communicating over MV power lines may provide communications between a backhaul point **10** and a transformer bypass device **30**. Thus, the backhaul point **10** and first modem **110** may encrypt and decrypt using a first encryption key. Similarly, the trans-



former bypass device **30** and second modem **111** may encrypt and decrypt using a second encryption key. The process steps for this embodiment would be similar to those described above with respect to FIG. **1a** and therefore, are not repeated here.

[0038] The embodiments of the present invention coupled to the MV power line (such as in FIG. **1b**) may use a coupler and signal conditioning circuitry described in U.S. Pat. No. 7,046,124, entitled “Power Line Coupling Device and Method of Using the Same” filed Jan. 21, 2003 and U.S. Pat. No. 6,980,090 entitled “Device and Method for Coupling with Electrical Distribution Network Infrastructure to Provide Communications” filed Mar. 10, 2003, which are hereby incorporated by reference. These incorporated applications also describe PLC devices, including some with wireless and power line communication capabilities such as a communication interface device, for which the present invention may provide communications.

[0039] Another embodiment of the present invention shown in FIG. **3** further includes a router **120** for controlling the flow of data packets through the repeater **100**. As shown in the figure, the router **120** is in communication with the first modem **110** and the second modem **111**. The router **120** may perform prioritization, filtering, packet routing, access control, and encryption. The router **120** of this example embodiment of the present invention uses a table (e.g., a routing or bridging table) and programmed routing rules stored in memory to determine the next destination of a data packet. The table is a collection of information and may include information relating to which modem (e.g., modem **110** or **111**) leads to particular groups of addresses (such as the addresses of the user devices connected to the customer LV power lines), the transformer bypass device, a backhaul point, another repeater, as well as the priorities for connections to be used, and rules for handling both routine and special cases of traffic (such as voice packets and/or control packets). Thus, in some embodiments information in the table may be used to determine which encryption key should be used to encrypt (or decrypt) a data packet.

[0040] The router **120** will detect routing information, such as the destination address (e.g., the destination IP address) and/or other packet information (such as information identifying the packet as voice data), and match that routing information with rules (e.g., address rules) in the table. Depending on the architecture of the device, the rules may be used to determine that packets in a particular group of addresses should be processed in a particular manner such as transmitted in a specific direction such as through the second modem **111** (e.g., if the packet has a destination IP address that corresponds to a user device connected to the LV power line), be encrypted with a particular encryption key, and/or be ignored (e.g., if the address does not correspond to a user device connected to the LV power line).

[0041] As an example, the table may include information such as the IP addresses (and potentially the MAC addresses) of the user devices on the repeater’s LV subnet, and/or the MAC addresses of the power line modems **50** on the repeater’s LV subnet. Alternatively, in the case in which the repeater is a MV repeater, the table may include information of the MV subnet mask (which may include the MAC address and/or IP address of the device’s backhaul point **10** and one or more transformer bypass devices).

Based on the destination address of the packet (e.g., an IP address), the router may pass the packet to the first modem **110**, the second modem **111**, or ignore the packet. Alternatively, if the IP destination address of the packet matches the IP address of the repeater **100**, the repeater **100** may process the packet as a request for data or other command. Thus, the repeater **100** may be designed for receiving and processing the commands described in the patent applications incorporated above, which may be transmitted by a power line server having a network element manager.

[0042] The router **120** may also prioritize transmission of packets. For example, data packets determined to be voice packets may be given higher priority for transmission through the repeater **100** than other data packets so as to reduce delays and improve the voice connection experienced by the user. Routing and/or prioritization also may be based on IP addresses, MAC addresses, subscription level, or a combination thereof (e.g., the MAC address of the power line modem or IP address of the user device).

[0043] In addition, the router **120** (or in the memory accessed by a separate processor communicating with the router **120**) may include a dynamic host configuration protocol (DHCP) server. When a user installs a new user device (and power line modem) on the LV subnet attached to the repeater **100**, the user device may need to be provisioned to identify itself on the network. To do so in this embodiment, the new user device transmits a DHCP request, which is received and routed by the repeater to the DHCP server. In response to the request, the repeater **100** may respond by transmitting to the user device the IP address and subnet mask for the user device, the gateway IP address for the device’s network interface to be used as the network gateway (e.g., the IP address of the modem **111** of the repeater **100**), and the IP addresses of the Domain Name Servers (DNS) all of which may be stored in memory by the user device. In addition, the repeater may transmit a “new user device” alert to a power line server (PLS) communicatively coupled to the PLSC.

[0044] Likewise, when first installed on the network, the repeater **100** may transmit a DHCP request, which is received and routed by a PLC device on the PLC network and routed to a DHCP server. In response to the request, the DHCP server may respond by transmitting to the repeater **100** the IP address and subnet mask for the repeater **100**, and the gateway IP address for the repeater’s network interface to be used as the network gateway (e.g., the IP address of the PLC device) all of which are stored in memory by the repeater. In addition, the PLC device may transmit a “new device” alert to the PLS.

[0045] In addition, the router **120** may include a module for performing network address translation (NAT). The router **120** may be configured to translate the destination address (e.g., an IP address) of a packet received from the PLC network side of the network to the address of the user device (or power line modem) on the customer premises side. If there is more than one user device, the translation may require additional information in the packet—such as information identifying a port—to allow the router **120** to determine the IP address corresponding to the user device that should replace the existing destination address in the packet. Similarly, the router may be configured to translate the destination of a packet received from the user device that is intended for the network.

[0046] Other embodiments of the invention may include a single modem that is programmed to attempt to decrypt each data packet using a first encryption key. If the decryption is successful, the modem may then encrypt the data packet using a second encryption key and subsequently transmit the encrypted packet over the power line. If the decryption with the first encryption key is not successful, the modem may then attempt to decrypt the received packet using a second encryption key. If the decryption using the second encryption key is successful, the modem may then encrypt the data packet using the first encryption key and subsequently transmit the encrypted packet over the power lines. If neither decryption is successful, the packet may be ignored.

[0047] Thus, the use of multiple encryption keys permits the creation of multiple logical networks. While these embodiments include two encryption keys, other embodiments may use three, four, or more encryption keys to create, and for use with, three, four, or more logical networks.

[0048] Such an embodiment, which is shown in FIG. 4, may be useful when the repeater **100** is communicatively coupled to the LV power lines near the distribution transformer **40** (e.g., where the LV power lines converge from multiple subscriber premises). Thus, the repeater may be in communication with multiple user devices at different customer premises **15a-c** via the LV power lines. Each encryption key may be used to decrypt and encrypt data for the user device (or another repeater) in the customer premises **15a-c** thereby forming a separate logical network for each customer premises **15a-c**. Consequently, this embodiment may provide isolation of the user devices of one customer premises **15a** from the devices of the other customer premises **15b-c**, and vice versa. In addition, a particular customer premises **15a-c** may have multiple user devices (or groups thereof) with each user device (or group of user devices) using a different encryption key and thereby being on a separate logical network as described herein. In addition, a device in communication with user devices in multiple customer premises that uses different encryption keys for each logical network may take the form of a transformer bypass device (described in the incorporated applications) instead of a repeater.

[0049] In addition, the repeater **100** of this embodiment may transmit data upstream through the distribution transformer **40** for reception by one or more PLC network devices communicatively coupled to the MV power line such as a transformer bypass device **30**, a MV repeater, or a backhaul device. Likewise, the one or more PLC network devices communicatively coupled to the MV power line may communicate downstream through the distribution transformer to the repeater **100**.

[0050] Furthermore, the repeater **100** (or bypass device) may communicate with the user devices in numerous customer premises **15a-c** via an optic fiber, a digital subscribe line (DSL), a coaxial cable, or wirelessly as opposed to via the LV power lines (or in addition to the internal LV power lines).

[0051] Likewise, some embodiments may be comprised of three, four or more modems that are coupled together such as via a router. In addition, alternate embodiments may use an algorithm, which simultaneously (or contemporaneously) attempts to decrypt with multiple keys (e.g., all the encryption keys available).

[0052] The LV repeater embodiment may be communicatively coupled to the LV power line near the customer premises **15a-c** or near (e.g., adjacent) the distribution transformer such as mounted on a utility pole or in, on, or to a transformer enclosure. If mounted near the transformer, the repeater **100** may be configured to provide communications for a user device in the customer premises over the LV power line. In addition, the repeater mounted near the transformer may transmit through the transformer onto the MV power line to provide communications between the user device and a MV PLC device such as a transformer bypass device (e.g., bypassing a different transformer), a backhaul point, a communication interface device (as described in the incorporated references), or a MV repeater.

[0053] In still another embodiment in which the present invention may be comprised of a single modem, the modem selects an encryption key based on information present in the packet (e.g., in the header of the packet) and information stored in memory (e.g., in the routing or bridge table). After decryption, the packet is encrypted using a different encryption key, which may be selected (e.g., retrieved from memory) based on programming and information stored in memory. After encryption, the packet is transmitted over the power line. In either single modem embodiment, the repeater **100** may also include a router that receives the decrypted packet from the modem and processes it as described above prior to, and to determine whether to, supply the packet back to the modem.

[0054] As will be evident from the above description, the repeater may be communicatively coupled (e.g., via the LV power lines) to a plurality of power line modems and associated user devices. Each modem (and associated user device) may use a different encryption key to create multiple logical networks. Alternatively, each user device may use the same encryption key (to permit networking between user devices) and the modems may only repeat data packets (using a different encryption key) with its address. Alternatively, one modem of the repeater and some subset of the user devices may use the same key (while other user devices use different keys), thereby permitting networking between the subset of user devices and to prevent the other devices from accessing the external PLC network.

[0055] Preferably, although not necessarily, the components of the repeater (perhaps excluding the coupler) are housed in an enclosure to provide environmental protection. The repeater **100** also may include a serial port, Ethernet port, USB, or a wireless transceiver to permit network personnel to access a processor in the repeater and to communicate with (or through) the user devices and network devices with which the repeater **100** is communicatively coupled.

[0056] Typically, each customer premises will be served by two LV energized conductors and a neutral conductor. The two LV energized conductors each carry 120V referenced to ground and are 180 degrees out of phase with each other to provide 240V potential between the two LV energized conductors. After the LV energized conductors enter the customer premises, typically only one LV energized conductor will be present at each wall socket where a power line modem or repeater might be installed (e.g., plugged in). Given this fact regarding the internal customer premises wiring, there is no way to know to which LV energized

conductor the power line modem (and user device) or repeater will be connected. In addition, the subscriber may move the power line modem and user device to another socket to access the PLCS and the new socket may be coupled to the second (different) LV energized conductor. Given these facts, the network designer must supply communications on both LV energized conductors and, therefore, would be motivated to simultaneously transmit the PLC RF data signal on each LV energized conductor referenced to the neutral conductor. However, in comparison to transmitting the RF data signals on both energized conductors referenced to the neutral, the following method of providing communications on the LV energized has been found to provide improved performance.

[0057] FIG. 5 illustrates an embodiment of a transmit circuit for transmitting the data signal provided by the repeater 100. Components to the left of the dashed line in FIG. 5c may be inside the repeater enclosure and those to the right may be outside the repeater enclosure. The transmit circuit of this embodiment (that forms part of or receives signals from a modem in the repeater) is comprised of a transformer that drives one conductor pair 43, which traverse through a common mode choke. The common mode choke provides a very low impedance to differential currents in the two conductors 43a,b, but provides a significant or high impedance to common mode currents (i.e., currents traveling in the same direction such as in or out). The two conductors 43a,b may also be coupled to ground by an impedance Z3, which may be a resistive impedance. In addition, each conductor 43a,b includes a series impedance Z1, which may be a capacitive impedance, or other low pass filter component(s), for impeding the 60 Hz power signal and permitting the RF data signal to pass unimpeded. Such impedances may be on either side of the common mode choke, but are preferably on the LV power line side of the choke.

[0058] In either embodiment, each conductor may also include a surge protection circuit, which in FIG. 5 are shown as S1 and S2. Finally, the cable 43 may be comprised of a twisted pair of conductors between the repeater enclosure and LV power line. As will be evident to those skilled in the art, the twisted pair cable 43 may have an impedance (determined by the geometry of the cable) as represented by Z2. This impedance Z2 may be modeled by a resistive component and an inductive component. The inductive component also may cause coupling between the two twisted wired conductors.

[0059] While not shown in the figures, the transmit circuit of either embodiment may also include a fuse in series with each conductor and a voltage limiting device, such as a pair of oppositely disposed zener diodes, coupled between the pair of conductors and may be located between the common mode choke and the transformer. Finally, one of the conductors of the repeater cable(s) 43 may be used to supply power to the power supply of the repeater 100 to power the modem(s) and other components of the repeater 100.

[0060] While these embodiments of the invention may drive the first and second LV energized conductors differentially to transmit the data signal (e.g., using OFDM), the power line modem (or indoor repeater) may transmit data signals from the customer premises to the repeater 100 by

applying the data signal to one conductor (e.g., one energized conductor) referenced to the other conductor such as the ground and/or neutral.

[0061] While in this embodiment the two energized conductors are opposite in magnitude, other embodiments may phase shift the signal on one conductor by forty-five degrees, ninety degrees, one hundred twenty degrees, one hundred eighty degrees, or some other value, in addition to or instead of differentially driving the two conductors.

[0062] The foregoing has described the principles, embodiments, and modes of operation of the present invention. However, the invention should not be construed as being limited to the particular embodiments described above, as they should be regarded as being illustrative and not as restrictive. It should be appreciated that variations may be made in those embodiments by those skilled in the art without departing from the scope of the present invention.

[0063] While a preferred embodiment of the present invention has been described above, it should be understood that it has been presented by way of example only, and not limitation. Thus, the breadth and scope of the present invention should not be limited by the above described exemplary embodiments. Similarly, while the preferred embodiment employs different encryption keys to isolate for various logical networks other embodiments may use other methods of isolating the logical networks. For example, a LV repeater (or other PLC device such as a bypass device) of another embodiment may use a first modulation scheme to communicate with the user device and another modulation scheme to communicate with another PLC device (e.g., a bypass device). In addition, or instead of, or in addition using different modulation schemes, the invention may use different forward error correction coding rates for each logical network. Thus, different modulation schemes, encryption, keys, and/or forward error correction coding rates can be used to provide isolation of each logical network.

[0064] Obviously, numerous modifications and variations of the invention are possible in light of the above teachings. It is therefore to be understood that within the scope of the appended claims, the invention may be practiced otherwise than as specifically described herein.

What is claimed is:

1. A method of communicating data over a low voltage power line, comprising:

receiving first data via the power line from a first user device disposed in a customer premises;

decrypting the first data using a first encryption key;

encrypting the decrypted first data using a second encryption key; and

transmitting the encrypted first data over the power line.

2. The method according to claim 1, further comprising selecting the first encryption key based on information included in the first data.

3. The method according to claim 2, wherein said selecting is based on information of a port included in the first data.

4. The method according to claim 2, further comprising storing information for selecting encryption keys in a memory.

5. The method according to claim 1, further comprising: receiving second data via the power line;

decrypting the second data using the second encryption key;

encrypting the decrypted second data using the first encryption key; and

transmitting the encrypted second data over the power line.

6. The method according to claim 5, wherein the second data is received from a power line communication device configured to provide communication services to the first user device.

7. The method according to claim 1, further comprising: receiving second data via the power line from a second user device disposed in the customer premises;

decrypting the second data using the first encryption key;

encrypting the decrypted second data using the second encryption key; and

transmitting the encrypted second data over the power line.

8. The method according to claim 7, further comprising: receiving third data via the power line from a power line communication device configured to provide communication services to the first and second user devices;

decrypting the third data using the second encryption key;

encrypting the decrypted third data using the first encryption key; and

transmitting the encrypted third data over the power line.

9. The method according to claim 1, further comprising selecting a destination device for the first data.

10. A method of communicating data over a low voltage power line, comprising:

receiving data via the low voltage power line;

selecting one of a plurality of encryption keys to decrypt the received data;

decrypting said received data with the selected encryption key;

encrypting the decrypted data with a second encryption key; and

transmitting the encrypted data over the power line.

11. The method according to claim 10, wherein at least some of the plurality of encryption keys are used for communicating with different communication devices.

12. The method according to claim 10, wherein the received data includes information of a port and said selecting is based on the information of the port.

13. The method according to claim 10, wherein said selecting is based on information included in the received data.

14. The method according to claim 10, wherein the received data is received from a user device disposed in a customer premises.

15. The method according to claim 10, wherein the received data is received from a power line communication device configured to provide communications to a plurality of user devices disposed in a plurality of customer premises.

16. The method according to claim 10, wherein the received data includes utility data.

17. The method according to claim 10, further comprising storing information for selecting the one of the plurality of encryption keys in a memory.

18. A method of providing communications between a first and second device over a low voltage power line, comprising:

receiving first data from the power line from the second device;

selecting a first encryption key from a plurality of encryption keys;

decrypting the received first data using the first encryption key;

encrypting the decrypted first data using a second encryption key;

transmitting the encrypted first data over the power line for reception by the first device;

receiving second data from the power line from the first device;

decrypting the received second data using the second encryption key;

encrypting the decrypted second data using the first encryption key; and

transmitting the encrypted second data over the power line for reception by the second device.

19. The method according to claim 18, wherein the first encryption key is selected based on information included in the first data.

20. The method according to claim 19, wherein the information included in the first data includes port information.

21. The method according to claim 18, wherein the first data is received from a power line communication device configured to provide communications to a plurality of user devices disposed in a plurality of customer premises

22. The method according to claim 18, wherein each of the plurality of encryption keys is associated with different communication devices than other encryption keys.

23. The method according to claim 18, wherein the first data is received from a user device disposed in a customer premise.

24. A device for communicating data over a power line, comprising:

a modem communicatively coupled to the power line; and wherein said modem is configured to:

receive first data from the power line;

decrypt received first data using a first encryption key of a plurality of encryption keys;

encrypt the decrypted first data using a second encryption key of the plurality of encryption keys; and

transmit the encrypted first data over the power line.

25. The device according to claim 24, wherein the first encryption key is selected based on information included in the received data.

26. The device according to claim 25, wherein the information included in the received data includes port information.

27. The device according to claim 24, wherein said modem is configured to:

- receive second data from the power line;
- decrypt received second data using the second encryption key;
- encrypt the decrypted second data using the first encryption key; and
- transmit the encrypted second data over the power line.

28. The device according to claim 24, wherein at least some of the plurality of encryption keys are associated with different communication devices.

29. The device according to claim 24, wherein the first data comprises data from a power line communication device configured to provide communications to a plurality of user devices disposed in a plurality of customer premises.

30. The device according to claim 24, wherein the first data comprises data from a user device disposed in a customer premise.

31. The device according to claim 24, further comprising a routing module in communication with said modem and including information to determine the encryption key to be used by said modem.

32. A device for communicating data over a power line, comprising:

a modem configured to be communicatively coupled to the power line;

wherein said modem is configured to:

- receive first data from the power line;
- use one of a plurality of encryption keys to decrypt received first data;
- use a different one of the plurality of encryption keys to encrypt the decrypted first data; and
- transmit the encrypted first data over the power line; and

a routing module in communication with said modem and including information to determine an encryption key to be used by said modem.

33. The device according to claim 32, wherein the encryption key used by said modem to decrypt the first data is based on information included in the received first data.

34. The device according to claim 33, wherein the information included in the received first data includes port information.

35. The device according to claim 32, wherein at least some of the plurality of encryption keys are associated with different communication devices.

\* \* \* \* \*