

C. P. HIGGINS.
RIVETING MACHINE.

No. 524,326.

Patented Aug. 14, 1894.

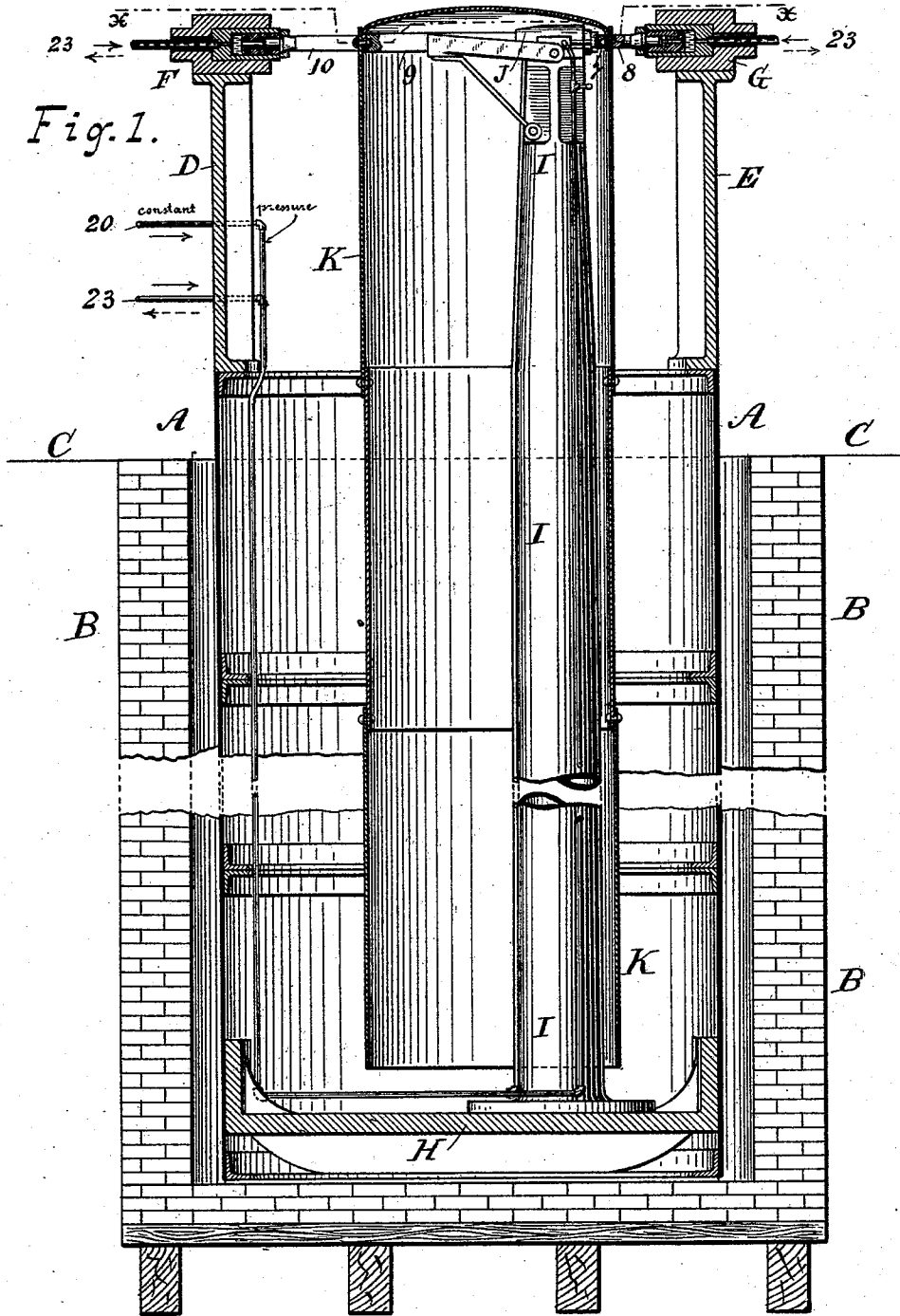

Witnesses
 Chas Hanemann
 E. MacEntee

Inventor
 Campbell P. Higgins
 By *his* Attorney
 Chas W. Forster

C. P. HIGGINS.
RIVETING MACHINE.

No. 524,326.

Patented Aug. 14, 1894.

Fig. 2.

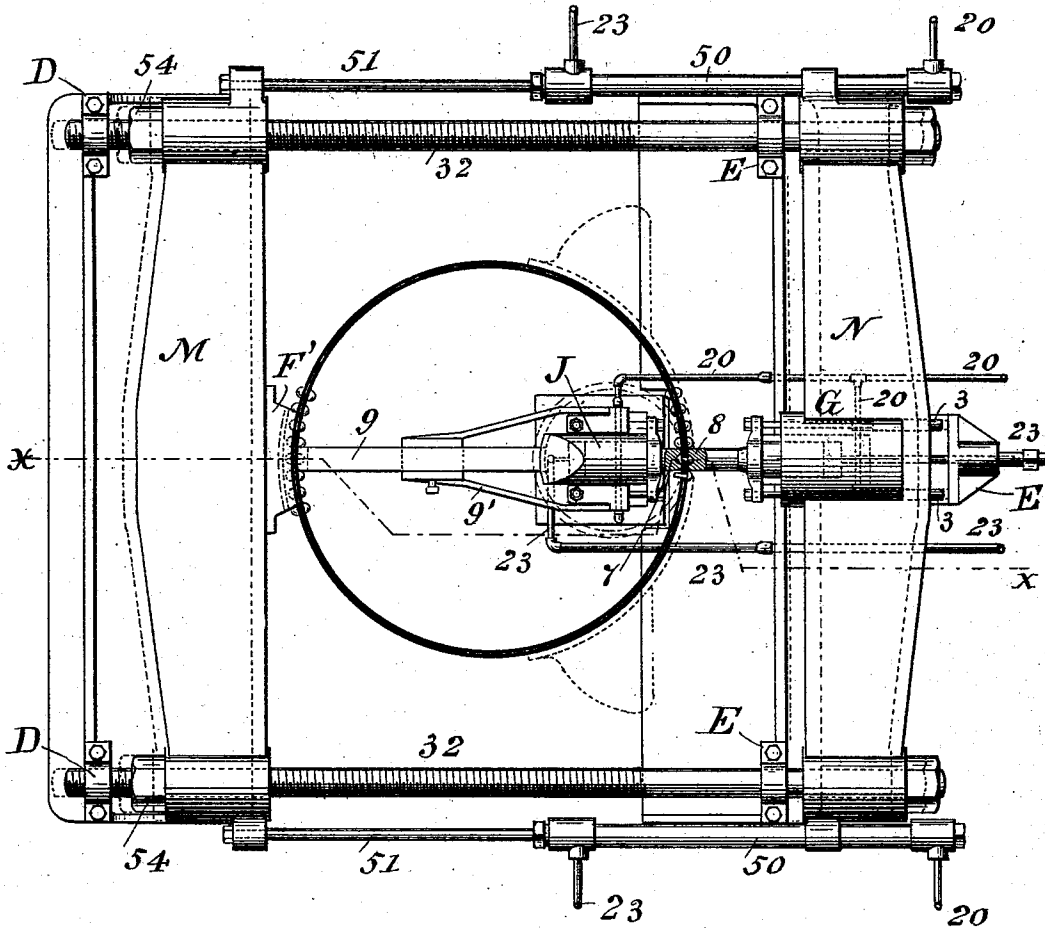
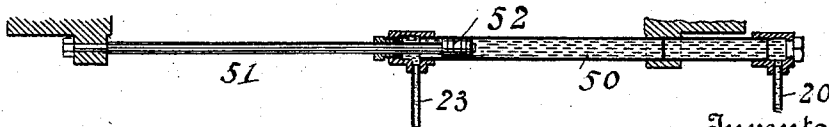

Fig. 2^a



Witnesses
 Chas. Hammann.
 E. Mac Carty.

Inventor
 Campbell P. Higgins
 By *his* Attorney
 Chas. M. Dober

C. P. HIGGINS.
RIVETING MACHINE.

No. 524,326.

Patented Aug. 14, 1894.

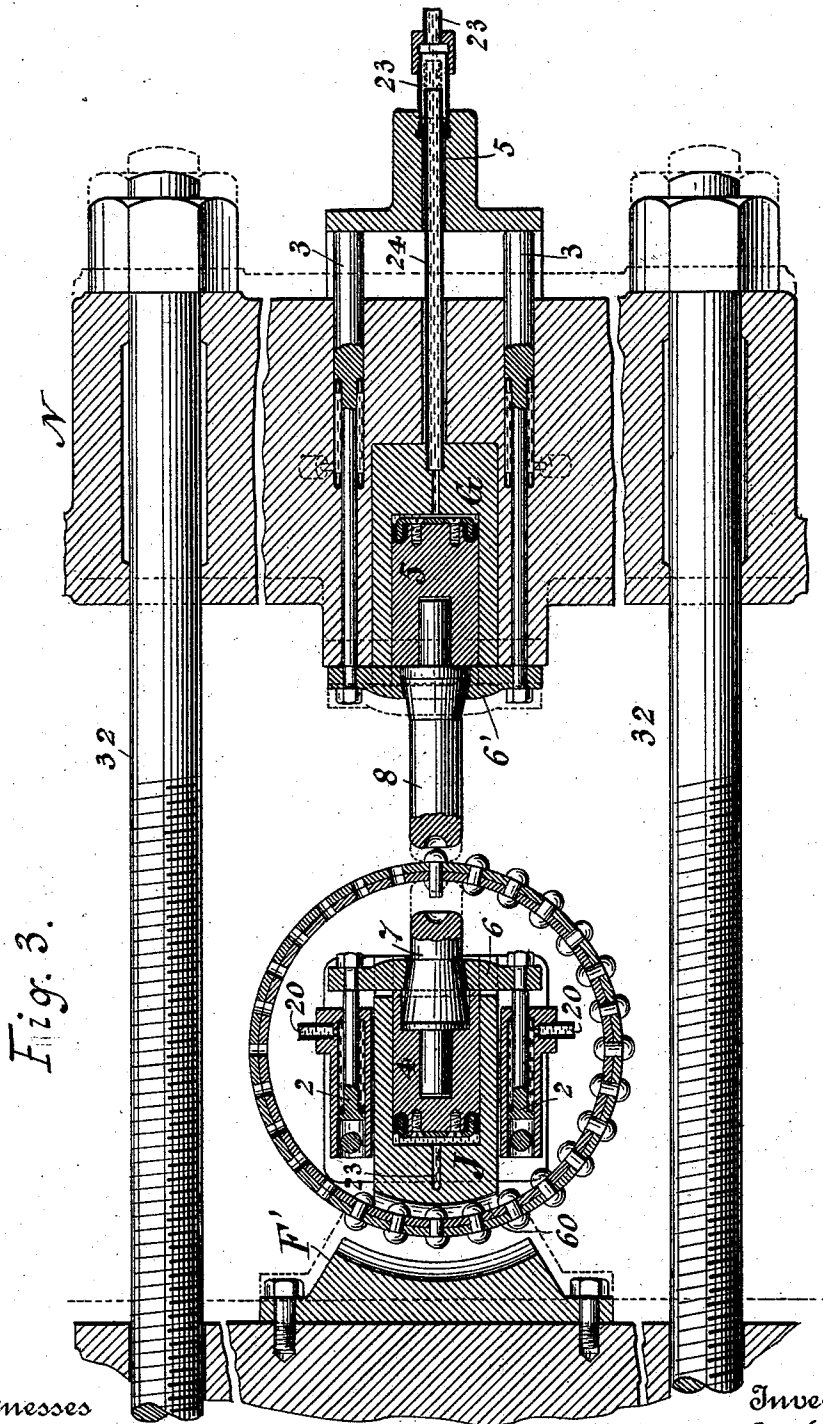

Fig. 3.

Witnesses
 Chas. Hanemann
 E. MacEntee

M

Inventor
 Campbell P. Higgins
 By his Attorney
 Chas. M. Dorlan

C. P. HIGGINS.
RIVETING MACHINE.

No. 524,326.

Patented Aug. 14, 1894.

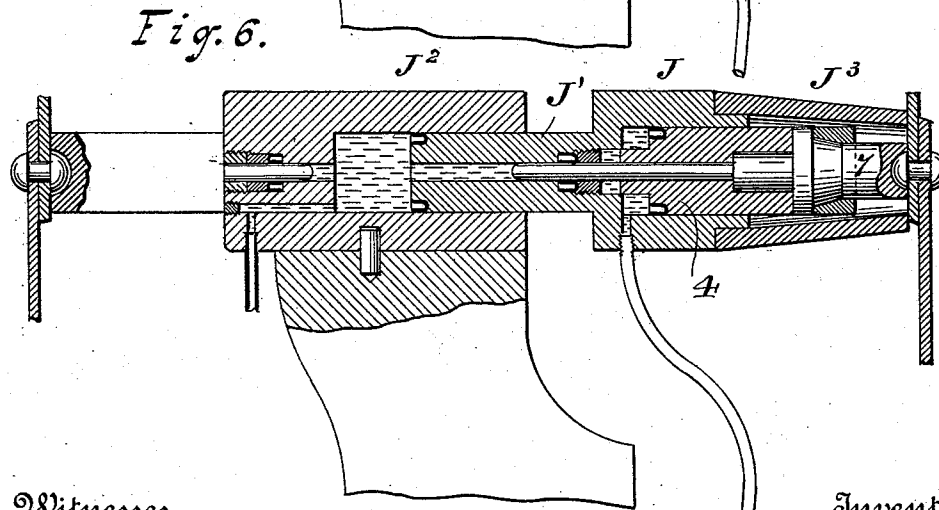
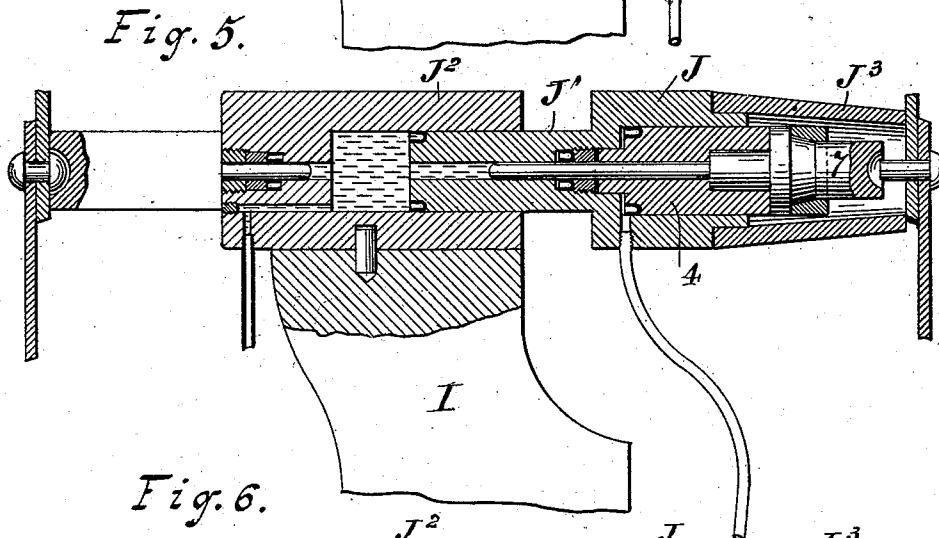
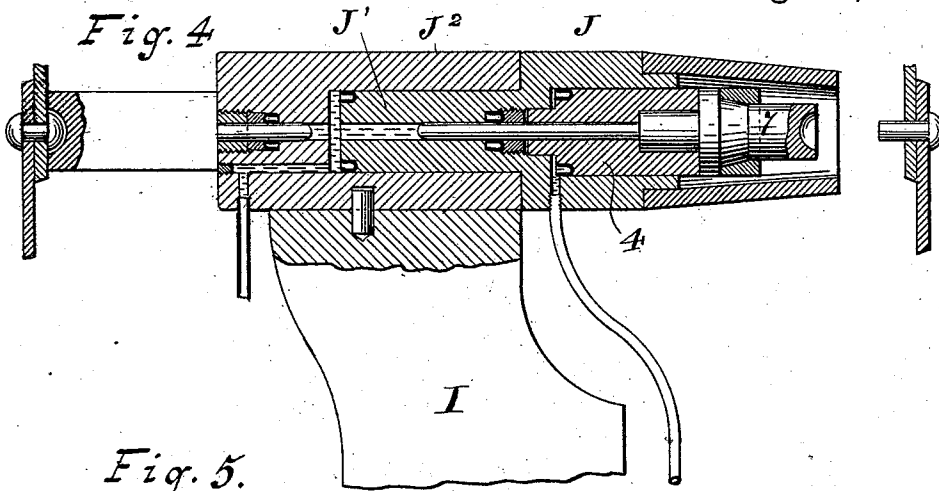

Witnesses
 Chas. Hanemann
 E. MacCall

Inventor
 Campbell P. Higgins
 By his Attorney
 Chas. W. Jordan

C. P. HIGGINS.
RIVETING MACHINE.

No. 524,326.

Patented Aug. 14, 1894.

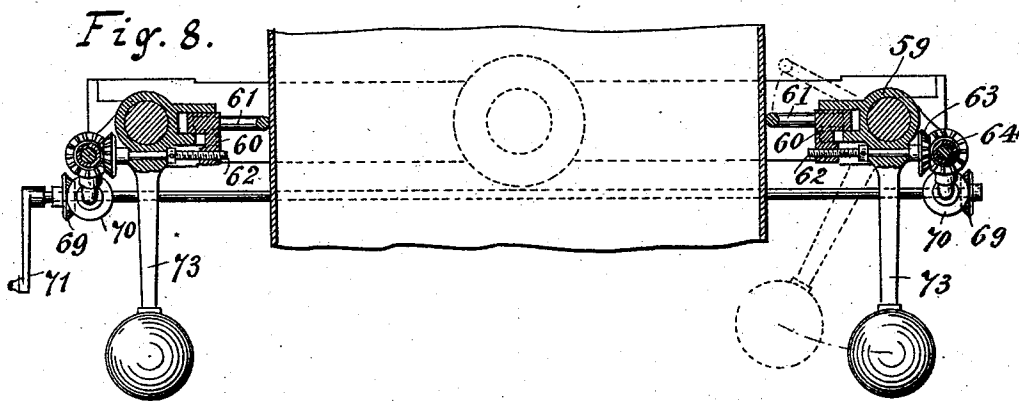
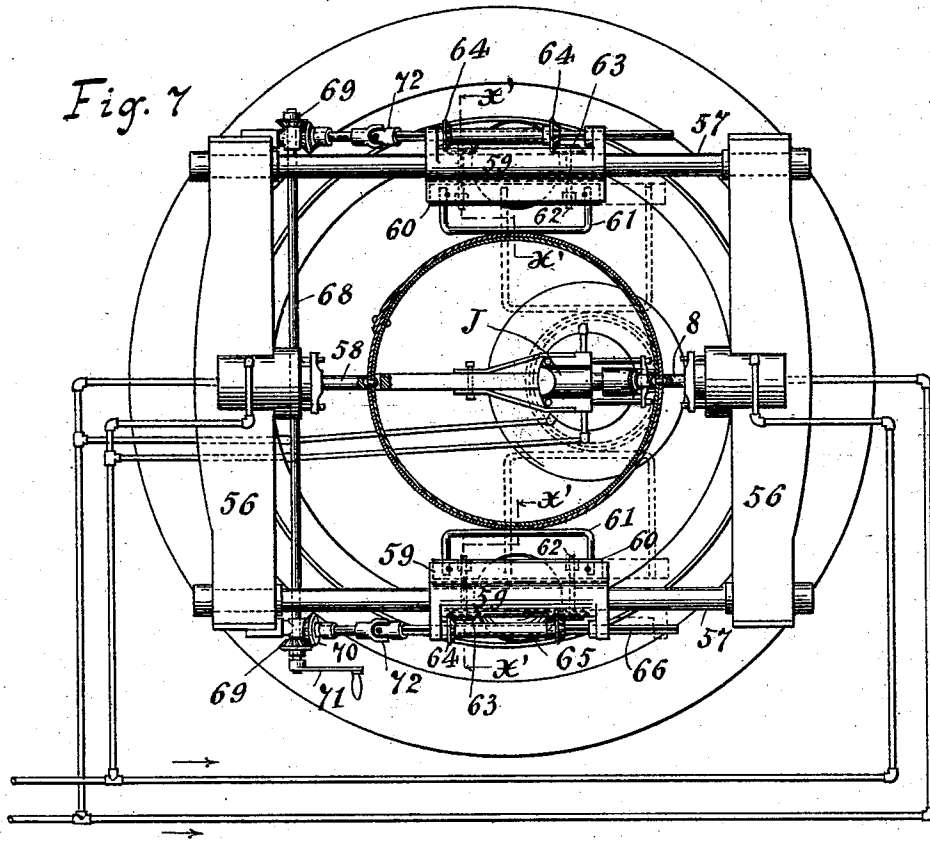

Witnesses
 Chas. Hanemann
 E. Moore Cutler

Inventor
 Campbell P. Higgins
 By His Attorney
 Chas. W. Corbin

UNITED STATES PATENT OFFICE.

CAMPBELL P. HIGGINS, OF ROSELLE, NEW JERSEY.

RIVETING-MACHINE.

SPECIFICATION forming part of Letters Patent No. 524,326, dated August 14, 1894.

Application filed May 27, 1893. Serial No. 475,788. (No model.)

To all whom it may concern:

Be it known that I, CAMPBELL P. HIGGINS, a citizen of the United States, residing at Roselle, in the county of Union and State of New Jersey, have invented certain new and useful Improvements in Riveting-Machines, of which the following is a specification.

The invention relates to riveting or punching machines of the general character described in my separate patent application, filed simultaneously herewith, Serial No. 475,787, requiring an interior support for the work having a long reach; and said invention is especially adapted for riveting cylindrical drums or other shells of wrought metal.

The invention consists in an apparatus having two movable punches, one exterior and the other interior to the shell or hollow work to be riveted, and having automatically adjustable means for forming, together with the punches, a continuous abutting connection from one exterior support, to and through the work, to another exterior support; the thrust of the punches being thereby transmitted in a continuous line through the work without lateral strain on the support of the interior punch.

In order to enable others skilled in the art to which the said invention appertains, to understand and use the same, I will proceed to describe its construction, explain its operation, and point out in the appended claims its novel characteristics.

Referring to the accompanying drawings, in which like characters of reference indicate corresponding parts throughout: Figure 1, is a sectional side elevation taken on the line $x-x$, Fig. 2; Fig. 2, a plan view; the head of the drum being in section according to the line $y-y$, Fig. 1; Fig. 2^a, a sectional view of one of the hydraulic cylinders; Fig. 3, an enlarged horizontal section, showing the interior construction of the actuating mechanism of the punches, and also the substitution of a proportionately smaller sized drum than that shown in the preceding figures. Fig. 4, is a longitudinal section on an enlarged scale, showing a modification of a punch and abutment mechanism, in a position prior to acting on a rivet. Fig. 5, is a section of the same showing the parts in another position. Fig. 6, is a section of the same showing the parts

in still another position. Fig. 7, is a plan view of another modification, and Fig. 8, is in section on the lines x', x' , of Fig. 7.

Referring first to Figs. 1, 2, 2^a and 3: A, represents the external structure or frame work of the apparatus which extends into the pit B.

The interior column I for supporting the interior punch 7 and the abutting parts interior to the work K, is mounted upon the base H of the frame work A, A, while the standards D, E, of said frame work support the movable frame M, N, that carries the abutment F'.

The frame-heads M, N, are united together by tie rods 32, 32, which are endwise movable in the supports D, D, E, E. The tie rods 32, are screw threaded in order to provide for securing the adjustment thereon of the head M, relatively to the head N. This adjustment of the head M, is produced by means of hydraulic cylinders 50, containing pistons attached to the rods 51. When the head M, is slid to the desired position, passing freely over the threaded rods 32, the nuts 54, which are the only parts threaded to said rods 32, are turned until they abut upon the head M, securing its adjustment firmly with reference to the head N.

The heads M, and N, when relatively adjusted, are free to move together by the sliding of their tie rods through the supporting bearings D, D, E, E.

The riveting punch 8, is mounted upon a plunger 5. The pistons 3, are attached to the punch 8, and the plunger 5, by means of the cross-head 6'. The supporting part E, of the frame A, is provided with an adjusting standard E', against which the extensions of the pistons 3, 3, may abut. Thus, when the plunger 5, and its punch 8, are retracted into the cylinder G, containing such plunger, the frame M, N, is pushed bodily away from said adjusting standard E', so that the abutment F' shall release and clear the work. The extensions of the pistons 3, 3, and their relation to the standard E', are so adjusted that their abutment shall occur after the punch 8, has retracted a sufficient distance from the rivet heads in the work to clear the same, as seen in Fig. 3.

In order to provide for the permanent water connection of the pipe 23, with the cyl-

inder G, irrespective of the movements of the frame M, N, the part 24, of the said pipe is telescoped into the part 23, through a suitable packing, as indicated in Fig. 3.

5 The riveting punch 7, interior to the work, is mounted in a plunger 4, within the cylinder J, whereby it is advanced by the introduction of water through the inlet 23. The punch 7, is retracted by means of its cross-head 6, and the retracting pistons 2, 2, attached thereto, actuated by pressure from the system of pipes 20.

10 When the work is of large diameter, as in Figs. 1 and 2, an intermediate abutting piece 9, is inserted between the cylinder J, and the work in line with the abutment F'. The piece 9, is provided with a suitable yoke 9', as indicated, which serves as a brace for holding it in position upon the column I.

15 20 When the work is of small diameter, as in Fig. 3, the back of the cylinder J, which is provided with a suitable groove 60, is permitted to abut directly on the work. Various pieces 9, may be interchanged or substituted to fit the sizes of the work.

25 The hydraulic connections for operating the several cylinder-plungers and pistons hereinbefore described, may be attached in various suitable or well known ways, and provided with valves for controlling the admission of fluid under pressure.

30 For convenience, the system of pipes 23, extend from a source of variable maximum pressure for advancing the punch-plungers 4, and 5, and performing the work, while the system of pipes 20, communicate with the retracting pistons 2, 2, and 3, 3, and are supplied with constant minimum pressure.

35 The pipes 20, may be connected to the constant pressure pipes of an apparatus for hydraulically intensifying and equalizing pressure, such as described in my separate patent application filed simultaneously herewith, Serial No. 475,787, and the pressure pipes 23, may be connected to the delivery pipe of the compressor described therein, and controlled by means of a suitable distributing valve adapted to alternately charge and exhaust such pipes 23, at each operation. The pipes 40 23, communicate also with the lesser area of the pistons 52, in the cylinders 50, to draw the frame M, N, up to the work, while the pipes 20, communicate constant minimum pressure to the greater area of said pistons 52, for retiring said frame to the position in Fig. 3. 45 The pipes 23, which communicate with the cylinders 50, are designed to be controlled by independent valves.

50 Referring now to the modifications shown in Figs. 4, 5, and 6, in which I employ in connection with the interior punch an abutment, or support, movable in advance of the movement of the punch; 7, designates the punch mounted in the plunger 4, movable within 55 the cylinder J. The cylinder J, has an extension J', movable in a cylinder J², mounted on the standard I. From the forward end of the

cylinder J, an abutment J³, extends and surrounds the punch 7. In this example the punch 7, is normally retracted within the 70 abutment J³, and the operation is as follows: The water pressure is first admitted to the interior of the cylinder J², and acting upon the inner end of the extension J', forces the cylinder J, the plunger 4, and the punch 7, to 75 the position shown in Fig. 5, with the abutment J³ tightly closed against the inner side of the work. Now, by admitting water pressure to the chamber J, and thus acting on the plunger 4, the punch 7, will be forced forward 80 to the position shown in Fig. 6, and heading the rivet. It is obvious that this movable abutment may be applied to the exterior-punch if desired.

85 Referring now to the modifications shown in Figs. 7 and 8, a fixed frame is shown, comprising cross-heads 56, and tie rods 57. In this example the riveting mechanism, or punches, may be the same, and operated in the same 90 manner as heretofore described. This example comprises a movable abutment arranged in line with the riveting mechanism, and it is shown as a punch 58, supported by one of the cross-heads 56, and constructed and actuated in a similar manner to the punch 8. 95 In this example I provide lateral supports for the work. These lateral supports are adjustable longitudinally of the machine, and to and from the work, for the purpose of adapting them to work of various sizes. For instance, for the 100 support laterally of small or large cylinders during the process of riveting. These lateral supports are constructed and operated as follows: 59, designates a cylindric block mounted on the tie-rod 57, so as to have a movement 105 longitudinally of said rod, and also to have a swinging movement relatively to the rod. 60, is a bar seated in a channel in the inner side of the block 59, and movable outward and inward relatively to the block. This bar 60, has a 110 bail 61, attached to it, and adapted to engage the outer side of the work operated upon, as shown in Fig. 7. This bail 61, is removable from the bar 60, so that another may be substituted for it, to accommodate the lateral 115 abutment to a cylinder, or work of smaller cross-section, as shown in dotted lines in Fig. 7. A lateral adjustment of this lateral abutment, or support, is made through the medium of screw-bolts 62, engaging tapped holes 120 in the bar 60, and extended through a portion of the block 59, in such manner as to rotate in the block, but having no longitudinal movement relatively to the block. The outer ends of the screw rods 62, are provided with 125 a beveled gear 63, meshing with the beveled gear 64, connected to a sleeve 65, mounted on a rod 66, having bearings in outwardly extending lugs of the block 59. The rod 66, is fixed, as to longitudinal movement, but the 130 block 59, and the sleeve 65, are movable longitudinally of the rod.

To impart a rotary movement to the sleeve 65, with the rod 66, the rod may be longitudi-

nally channeled, and the sleeve provided with a feather to extend into this channel.

To impart a simultaneous adjustment to the lateral abutments, or supports, I employ a shaft 68, mounted in bearings secured to the frame of the machine, and having beveled gears 69, engaging with beveled gears 70, on the rods 66. The shaft 68, may be rotated by means of a crank 71. As the shaft 68, is located below the horizontal plane of the lateral abutments, or supports, the rods 66, are provided with universal joints 72.

The blocks 59, may be moved longitudinally of the tie-rods 57, by hand power.

As the work is lifted from the machine in the usual manner, the lateral abutments, or supports, may be deflected upward, as shown in dotted lines at the right-hand end of Fig. 8, by turning the blocks 59 on the tie-rods 57.

After the removal of the work, the said lateral supports will be automatically returned to their normal or horizontal position by means of the weighted arm, or counter-balance 73, extended from the lower side of the blocks 59. I have termed these devices last described as lateral abutments, or supports, because they operate at substantially right-angles to the operation of the riveting mechanism and the aligned support or abutment.

The frame heads N, N, or external supports may be permanently connected at a given distance apart as in Fig. 7, or made adjustable with reference to one another as in Fig. 2, and provided with means for retaining them at a given distance during the performance of the work; and said supports may be supported in a proper working position by obvious other means than that shown; and the riveting mechanism 8, and 7, and the resisting mechanism comprising the parts J, or 9, or F', or 58, or any or all of them, abut in a continuous series from one said external support M to and through the hollow work to the other said external support N.

Having thus fully described my invention, what I claim is—

1. A riveting machine, constructed with opposing punches, and adapted respectively for operation on a rivet at the outside and inside of a drum or shell, hydraulic rams operating said punches, an abutment piece adapted for insertion between one side of the drum or shell and the interior punch, and an exterior abutment opposing the interior abutment piece, substantially as described, and for the purposes set forth.

2. A riveting machine, constructed with a supporting frame, two supports exterior to the work connected together, and movable on said frame, one support carrying a riveting punch, the other carrying an abutment, said punch and abutment adapted for operation at opposite exterior sides of the work, and means for supporting the interior sides of the work, substantially as described.

3. The combination in a riveting machine of a supporting frame, two supports at opposite sides of the work connected together and movably mounted on said frame, a riveting punch movably mounted on one of said supports, and means for advancing or retracting the opposite support toward or from the work by the advancing or retracting movements, respectively, of said punch.

4. A riveting machine constructed with a supporting frame, two supports exterior to the work connected together, one support carrying a riveting punch, the other carrying an abutment, said punch and abutment being adapted for operation at opposite exterior sides of the work, means for supporting the interior sides of the work, and the adjustable lateral supports, or abutments, substantially as specified.

5. The combination with riveting mechanism, substantially such as described, and a frame comprising tie-rods, of the abutments or supports, movable longitudinally on said tie-rods, and mechanism for adjusting said abutments or supports, laterally, substantially as specified.

6. The combination with riveting mechanism, substantially such as described, and a frame comprising tie-rods, of the abutments or supports, having a longitudinal or swinging movement relatively to said tie rods, and mechanism for causing a lateral adjustment of said abutments or supports, substantially as specified.

7. The combination with riveting mechanism, substantially such as described, and a frame comprising tie-rods, of the lateral abutments or supports, having a longitudinal and swinging movement relatively to said tie-rods, and a counter-balance for returning said abutments, or supports, to a normal or horizontal position, substantially as specified.

CAMPBELL P. HIGGINS.

Witnesses:

L. D. BURNHAM,
W. A. PEARSALL.