



INTERNATIONAL APPLICATION PUBLISHED UNDER THE PATENT COOPERATION TREATY (PCT)

(51) International Patent Classification⁵ : C08J 3/28, C08K 9/10 F16L 55/165, 55/18	A2	(11) International Publication Number: WO 93/15131 (43) International Publication Date: 5 August 1993 (05.08.93)
(21) International Application Number: PCT/GB93/00107 (22) International Filing Date: 18 January 1993 (18.01.93) (30) Priority data: 92810029.6 17 January 1992 (17.01.92) EP <i>(34) Countries for which the regional or international application was filed:</i> 07/834,683 11 February 1992 (11.02.92) US 07/990,972 15 December 1992 (15.12.92) US (71)(72) Applicants and Inventors: CHANDLER, Brian, Burnett [GB/AT]; Steinermark, A-8933 St Gallen 60 (AT). MITCHELL, David, Campbell [GB/CH]; 20, chemin des Rasses, CH-1255 Veyrier (CH).		(74) Agent: BAILEY WALSH & CO.; 5 York Place, Leeds LS1 2SD (GB). (81) Designated States: AT, AU, BB, BG, BR, CA, CH, DE, DK, ES, FI, GB, HU, JP, KP, KR, LK, LU, MG, MN, MW, NL, NO, NZ, PL, RO, RU, SD, SE, US, European patent (AT, BE, CH, DE, DK, ES, FR, GB, GR, IE, IT, LU, MC, NL, PT, SE), OAPI patent (BF, BJ, CF, CG, CI, CM, GA, GN, ML, MR, SN, TD, TG). Published <i>Without international search report and to be republished upon receipt of that report.</i>
(54) Title: CURABLE RESIN SYSTEMS AND APPLICATIONS THEREOF		
(57) Abstract <p>A method of producing resin articles from a resin reaction system including an uncured resin material and added radiation activatable matter therein. In one case said matter is microencapsulated catalyst and, upon application of ultrasonic energy the catalyst is released to initiate cure of the resin. The catalyst is one which is water insoluble and encapsulated with gelatin. In another case, radiation reactive particles such as iron oxide particles are incorporated in the resin and are caused to heat by application of an alternating magnetic field to cure the resin. The field is generated by annular electromagnetic means (14X) borne by a core member (10X) drawn by a cable (12X) through the pipe (1X) and tube (2X). The process is particularly well suited to a replacement pipe and method of installing the replacement pipe within an existing conduit with the resin being cured by passing appropriate radiation generator through a fluid inside the inflated replacement pipe. The invention is of particular interest in mending leaky sewer pipes and the like as the presence of flowing liquid or the like does not affect the radiation.</p>		

FOR THE PURPOSES OF INFORMATION ONLY

Codes used to identify States party to the PCT on the front pages of pamphlets publishing international applications under the PCT.

AT	Austria	FR	France	MR	Mauritania
AU	Australia	GA	Gabon	MW	Malawi
BB	Barbados	GB	United Kingdom	NL	Netherlands
BE	Belgium	GN	Guinea	NO	Norway
BF	Burkina Faso	GR	Greece	NZ	New Zealand
BG	Bulgaria	HU	Hungary	PL	Poland
BJ	Benin	IE	Ireland	PT	Portugal
BR	Brazil	IT	Italy	RO	Romania
CA	Canada	JP	Japan	RU	Russian Federation
CF	Central African Republic	KP	Democratic People's Republic of Korea	SD	Sudan
CG	Congo	KR	Republic of Korea	SE	Sweden
CH	Switzerland	KZ	Kazakhstan	SK	Slovak Republic
CI	Côte d'Ivoire	LK	Sri Lanka	SN	Senegal
CM	Cameroon	LJ	Liechtenstein	SU	Soviet Union
CS	Czechoslovakia	LU	Luxembourg	TD	Chad
CZ	Czech Republic	MC	Monaco	TG	Togo
DE	Germany	MG	Madagascar	UA	Ukraine
DK	Denmark	ML	Mali	US	United States of America
ES	Spain	MN	Mongolia	VN	Viet Nam
FI	Finland				

CURABLE RESIN SYSTEMS AND APPLICATIONS THEREOFBACKGROUND OF THE INVENTION

This invention relates generally to curable resins and more particularly to resins which have been conditioned in order that they may be cured to produce rigid articles in a most convenient and efficient manner.

The use of curable synthetic resins to produce rigid articles is extensive, indeed nearly all plastics whilst too numerous to mention here, are synthetic resins initially, which means that they go through a liquid or plastic phase before being shaped and hardened into the final article.

In the majority of uses, the processing of the resin including the curing of same is performed under controlled conditions according to manufacturing methods established over many years, but circumstances do arise wherein it is required to control the hardening or curing of the resin until the appropriate instant in time to ensure best utilization of the resin.

A particularly good example of this situation arises in connection with the curing of a resin which is used to impregnate a resin absorbent tubular structure (herein the "lining tube or pipe") which is to be used for lining an underground pipeline or passageway such as a sewer. In such utilization, which is now practiced widely throughout the world, the impregnated lining tube is inflated (by gas such as air, steam and/or liquid such as water) against the pipeline or passway surface whilst the resin is uncured, and whilst the lining tube is so held in position, the resin is allowed or caused to cure whereby the cured resin with the absorbent tubular structure embedded therein forms a self

supporting rigid pipe, which may or may not bond to the pipeline or passageway wall. The purpose of this operation is to rehabilitate and/or repair the passageway or pipeline. A particular advantage of the provision of a self supporting rigid pipe is that bonding to the existing pipeline is not necessary, as is the case with some lining systems but it is to be mentioned that this invention can be applied to pipe-lining systems where the impregnated tube does bond to the existing pipeline or passageway, such systems being those wherein the lining tube is of relatively small thickness e.g. 5 mm or less and the resin acts like a bonding medium rather than an impregnating medium.

Also the lining tube when the resin is in the uncured state may not strictly be a tube in that it may be a web folded into tubular form so that its edges overlap and such edges become fused or held relatively together only when curing in place has been effected. In fact, this arrangement provides the advantage that the overlapping edges can slip relatively as the tube is being inflated so that the tube will best fit to the passageway surface.

Examples of methods of lining of underground pipelines and passageways using impregnated lining tubes which are cured in place are contained in many patent specifications of which examples are U.K. Patent No. 1,340,068 which is the original patent for this technology and U.K. Patent No. 1,449,445.

All or by far the majority of the methods which are practised throughout the world using cured in place lining tubes for lining underground pipelines and passageways use heat for the curing of the resin, the application of heat causing a catalyst in the resin to commence cross linking of the resin molecules and crystal formation; the curing reaction is exothermic and heat is internally generated and the curing

process accelerates.

One disadvantage of this arrangement is that even if heat is not applied to the impregnated lining tube, under ambient conditions the resin will eventually cure in a matter of days and of course if curing takes place before the lining tube is in place on the passageway of pipeline surface, the lining tube is completely lost and must be scrapped. This can represent a considerable loss if not complete loss of profit on a contract. Should the lining tube cure when it is part way inside the pipeline or passageway, then the consequences financially could be disastrous for the contractor. In order to avoid the problem of the resin curing too soon, i.e. before the lining tube is in place, contractors have resorted to extensive measures, in particular to keeping the impregnated tube refrigerated until it is to be used on site. This means that the tubes must be delivered to the site in refrigerated vehicles.

Another disadvantage is that when heat is applied it is applied usually by hot fluent medium e.g. water or steam which fills the inside of the inflated lining tube. If the pipeline is one which constantly carries a fluid or liquid such as sewage the normal flow must be diverted whilst the curing continues. Especially in the case of sewage, this represents a considerable inconvenience and more significantly extra costs which can mean in some cases the loss of contracts to cheaper methods.

Ironically, however, once the tubes have been put in place, it is desirable that the resin should be cured as fast as possible, as the sooner the resin cures, the sooner the contractor can leave the site. It is to be noted that the contractor will often be given or will often quote a relatively short time for completion of the work, usually

undertaken during the night. It is very important therefore that the work be completed in the shortest possible time, especially in these cases where the performance of the work involves the rendering inoperative (as it does in many cases) of a sewage system or the blocking or obstructing of traffic.

To perform the contract therefore the contractor must on the one hand have a factory or plant at which the tube is impregnated, a vehicle for keeping the impregnated tube refrigerated and a vehicle with a heating means for heating the fluid which inflates the tube when in place, in order to effect the curing of the resin, as well as the necessary equipment for putting the tube into place.

There is also the dilemma concerning the resin. On the one hand it is desirable that it should have as long a shelf life as possible to give the contractor plenty of time to place the tube in the pipeline or passageway before curing. On the other hand, when the tube is in place, it is desirable that curing should take place as quickly as possible. Unfortunately this dilemma has proved so far to be insoluble as the additives such as retarders for the resin which can increase shelf life of the resin also increase the cure time of the resin.

Consequently, when a contractor has to perform a contract, he must have the lining tube manufactured, and, immediately before he is to insert the lining tube, he impregnates the tube with the resin, transports it to site (which may be remotely located) as quickly as possible, and inserts the lining tube and cures it as quickly as possible. As soon as the resin is mixed with its catalyst for impregnation of the lining tube, there is a time countdown, and the contractor is racing against time.

The industry is aware of this problem and some attempts have been made to solve it by developing special resins which are curable by light radiation, and examples of such resins are disclosed in European Patent Specification Nos _____ and _____, and methods of cured in place lining with impregnated lining tubes using light radiation are disclosed in U.S. Patent No. 4,581,247 and 4,680,066.

Light radiation curable resins however include catalysts which are activatable by the suns rays and therefore the impregnated lining tubes must be contained in opaque wrappings during storage and transportation to avoid premature curing.

Light radiation curable resin does however have the advantage that curing of same can be controlled and theoretically has an infinite shelf life. When it comes to curing the in place impregnated tube however, problems arise. Firstly, special ultra violet light sources are needed to cure the resin; secondly, when, as is often the case, the inflating medium is water, that water may be dirty in which case light curing cannot be performed, and in any case waterproof light sources have to be designed and manufactured as no such sources are commercially available. When the flowing liquid in the pipeline or passageway is opaque, as sewage is, it must be diverted and the use of light curing equipment suffers from the same disadvantage in this respect as heating methods. For these reasons, in practice, light curing of in place impregnated lining tubes has not been successful and has not replaced the traditional heating methods.

SUMMARY OF THE INVENTION

The present invention seeks to provide curable resin systems for the production of rigid articles wherein the resin can be

cured readily and quickly, but retains a long to infinite shelf life (e.g. one year or more) making it particularly suitable for use in cured in place lining systems for pipelines and passageways; the invention at this time is not however to be considered as limited to this field of application and it is useable in any circumstances as appropriate where resin is to be formed into a rigid article.

According to the present invention in its most general aspect the resin includes or is located adjacent inert matter which is not affected by ambient conditions such as ambient heat and light, but such matter is susceptible to applied radiation to such an extent to cause curing or commencement of curing of the resin.

There are various forms which the said matter can take, and such forms can be used singly or in combination.

Thus, the matter may comprise microencapsulation shells in which is contained a catalyst for the resin, the shells being susceptible to the ultrasonic radiation to rupture the cells to release the catalyst, and hence cause commencement of the cure.

Again the added matter may be magnetic/metallic particles or the like and may be susceptible to alternating electromagnetic radiation to magnetise same according to the well known hysteresis effect, and the hysteresis loss shows up as heating of the particles, and the heat in turn causes the resin to cure or commence its cure.

Furthermore, the matter may be electrically conductive and/or magnetisable fibres and/or filaments which form current or magnetisable loops whereby, upon being subjected to alternating electromagnetic radiation, induced currents

and/or induced hysteresis effects occur which cause the added matter to heat up and the heating effect cures the resin or causes commencement of the curing of the resin.

The various forms of matter may be used together and the resulting resin may be treated by the various forms of radiation simultaneously or in sequence. Thus, the magnetisable conductive, magnet and/or metallic particles or fibres may be embodied in the micro encapsulation shells or the catalyst trapped therein in addition or as an alternative to being embodied in the resin.

As to the form of the invention wherein microencapsulated catalyst is employed the resins include microencapsulation shells or coatings which are ruptured by ultrasonic energy, and the invention provides a method of curing to produce cured resin articles; specifically but not exclusively uncured replacement pipe including the microencapsulated catalyst. Such a pipe is inserted into an existing pipeline or passageway to be relined and then cured after application of ultrasonic energy to release the catalyst.

U.S. Patents Nos 4,101,501; 4,154,774 and 4,362,566 disclose that it is known to use microencapsulated catalysts in resins to control the time when the catalysts are made active by rupturing the capsule shells, but such patents are concerned with rupturing the shells by the application of mechanical pressure.

Generally speaking, in accordance with this aspect of the invention, a method of curing resinous material including microencapsulated catalysts to yield a rigid cured resin article is provided. In one embodiment of the invention, the resin is formulated with catalysts, initiators and inhibitors which provide a thermally stable resin with a sensitivity to

ultrasound. In another embodiment, the resin includes microencapsulated catalyst which will not be released to contact the monomer until application of ultrasonic energy to release the catalyst or promoter and initiate the curing.

In a preferred embodiment of this aspect of the invention, the microencapsulated catalyst is admixed with a curable resinous material disposed in a fibrous carrier layer having at least one lining layer. The fibrous carrier can take the shape of any desired article, such as a boat or molded part for a vehicle.

In the most preferred embodiments this aspect of the invention, the fibrous carrier is a part of a lining pipe to be installed within an existing conduit needing to be relined. After the lining pipe is inserted into the existing conduit, it is inflated by the application of fluid under pressure so that the lining pipe conforms to the inner dimensions of the existing conduit. Installation may involve everting of the lining pipe. The fluid is preferably water which maintains the lining pipe inflated as an ultrasonic device is moved through the water inside the lining pipe to apply ultrasonic energy to release the microencapsulated catalyst to initiate the cure of the resinous material.

Accordingly, it is an object of this aspect of the invention to provide an improved method of producing resin articles from a resin reaction system including microencapsulated catalysts by the application of ultrasonic energy.

Another object of this aspect of the invention is to provide an improved lining pipe and method for installing the lining pipe in existing conduits.

Still another object of this aspect of the invention is to

provide an improved method to install a lining pipe which is cured after application of ultrasonic energy to release the catalyst.

Still other objects and advantages of this aspect of the invention will in part be obvious and will in part be apparent from the specification and drawings.

In all aspects of the invention wherein magnetic particles or other added matter responsive to radiation are/is used various objectives are in view, namely;-

to reduce the amount of energy required for the hardening of the lining pipe; and

to enable a sewer or other liquid conveying pipeline or conduit to be lined while in use without the curing action being appreciably affected by flowing sewage or other liquid or material.

In another aspect of the invention there is provided a method of curing a heat-curable substance contained in a lining pipe, apparatus for use in the method, and a liner pipe suitable for the method, as set forth in the appended claims.

The invention in its various aspects accordingly comprises the several steps and the relation of one or more of such steps with respect to each of the others, and the article possessing the features, properties, and the relation of elements, which are exemplified in the following detailed disclosure, and the scope of the invention will be indicated in the claims.

DESCRIPTION OF THE DRAWINGS

For a fuller understanding of embodiments of the various aspects of the invention, reference is had to the following description taken in connection with the accompanying drawings, in which:

Fig. 1 is a cross-section of an impregnated lining pipe in accordance with the invention and when in a flattened condition;

Fig. 1A is an enlarged cross sectional view of part of the lining pipe shown in Fig. 1;

Fig. 1B is a still further enlarged view of one of the microcapsules used in the resin system of Fig. 1A;

Fig. 1C is a view similar to Fig. 1B, but showing a modified arrangement;

Fig. 2A, 2B and 2C are schematic drawings illustrating the steps of installing the lining pipe in an existing pipeline and curing it in accordance with the invention;

Fig. 3 is a perspective view of an ultrasonic curing device suitable for curing the resin including the microencapsulated catalyst in accordance with the invention;

Fig. 4 is a perspective view of a multiple transducer ultrasonic curing device for use in curing the resin including microencapsulated catalyst in accordance with the invention;

Figs. 5 and 7 are respectively a cross-section along line I-I

of Fig. 7 and an axial section along line III-III of Fig. 5 of a round concrete pipe 1X and of a sleeve-like liner 2X according to this aspect of the invention provided in pipe 1X, and showing also, partly in axial section in Fig. 7, apparatus 10X according to the invention used during a pipe lining operation;

Fig. 6 is a sectional view on an enlarged scale of a portion of the lining 2X shown in Figs. 5 and 7; and

Fig. 8 is top end view and Fig. 9 is a side view of another apparatus used during a lining operation.

DESCRIPTION OF THE PREFERRED EMBODIMENTS

A resin article arranged in accordance with the invention can include a resin portion disposed on one or between two lining layers. At least the inner liner should be impermeable to the resin and fluids to be encountered in the curing process. The resin section can include a carrier, which may be fibrous, containing the curable resin material with microencapsulated catalyst dispersed therein.

Various thermosetting resin compositions that will cure in the presence of a catalyst are suitable. Examples include allyl, bismaleimide, epoxy, phenolic, polyester, polyamide, polyurethane, or silicone resins and combinations thereof. The carrier can be any acceptable fibrous material, such as felt and the like, or a web or mesh and the like and the resin section will become rigid and strong once the resin is cured.

Thermosetting unsaturated polyester resin compositions are particularly well suited for use in accordance with the invention. Unsaturated polyesters are extremely versatile and can be acceptably rigid, corrosion resistant and weather resistant for many applications, including replacement pipe applications. Such unsaturated polyester resins have been used widely in applications such as constructing boats, exterior automotive parts and bowling balls.

Commercial unsaturated polyester resins include an unsaturated polyester dissolved in cross-linking monomer and generally contain an inhibitor to prevent cross-linking until the resin is to be cured. The unsaturated polyester is the condensation product of an unsaturated dibasic acid

(typically maleic anhydride) and a glycol. The degree of unsaturation varies by including a saturated dibasic acid, such as phthalic anhydride, isophthalic acid or adipic acid. The glycol is usually propylene glycol, ethylene glycol, diethylene, dipropylene glycol, neopentyl glycol and various combinations thereof.

Styrene is a particularly well suited cross-linking monomer. Other acceptable cross-linking monomers include vinyl toluene, methacrylate, alpha methyl styrene and diallyl phthalate. Conventional inhibitors include hydroquinone, parabenzquinone and tertiary butyl catechol.

Depending on the application for the cured product, chemical resistance can be achieved by using isophthalic acid, neopentyl glycol, trimethyl pentanediol and hydrogenated bisphenol A. Weathering resistance can be improved by using neopentyl glycol, methyl methacrylate and ultraviolet absorbers, such as fenzophenones and benzotriazoles.

Polyester resin is cured by a free radical addition reaction. Organic peroxides can serve as a catalyst and can be the source of the free radicals. At elevated temperatures, heat decomposes the peroxide to produce the free radicals. Peroxyesters and benzoyl peroxide are organic peroxides used at elevated temperatures.

The resin component can also include a curing promoter. The promoter can cause the organic peroxide to decompose and form free radicals. Cobalt octoate is an appropriate promoter, generally used with methyl ethyl ketone peroxide (MEKP) as the catalyst. When benzoyl peroxide is used as the catalyst, diethylaniline or dimethylaniline is used as promoters.

Epoxy resins are also well suited to be included in the resin

section of replacement pipe constructed in accordance with embodiments of the invention. The term epoxy resin refers to a variety of cross-linking materials that contain the epoxy or oxirane group. The epoxy group is reactive with a wide variety of curing agents or hardeners. The curing reaction converts the low molecular weight resin into a three dimensional thermoset structure. Standard epoxy resins are based on bisphenol A and epichlorohydrin as raw materials. Other types are based on the epoxidation of multifunctional structures derived from phenols and formaldehyde or aromatic amines and aminophenols.

Epoxy resins can be cured at low temperatures with aliphatic polyamines or polyamides. Cures at elevated temperatures can occur with anhydrides, carboxylic acids, phenol novolac resins, aromatic amines or melamine, urea and phenol-formaldehyde condensates. Cures at lower temperatures generally require a two component system including resin separated from hardener prior to the curing reaction. Cures at elevated temperatures can be performed with a one component mixture of ingredients which will be stable at ambient temperatures. These are more suitable for increasing the pot-life of the resin.

Intermediate molecular weight solid epoxy resins can be cured through both the terminal epoxy group and the pendant hydroxyl group in the polymer backbone. Typical cross-linking agents include dicyandiamide or phenolic group terminated poly(hydroxyethers) with imidazole accelerators. Medium molecular weight resins can also be utilized to form epoxy esters by reaction with fatty acids at high temperatures, whereby both the terminal epoxy groups and the secondary hydroxyl groups are converted to ester linkages, the latter by azeotropic removal of water. Other intermediate molecular weight epoxy resins are prepared by

chain extension of liquid epoxy resins and brominated bisphenol A.

High molecular weight epoxy resins, which can be classified as poly(hydroxy) ethers), contain low concentrations of epoxy end groups. They are cured via the hydroxyl groups, typically with aminoplasts (melamine or urea-formaldehyde resins) or phenoplasts (phenol-formaldehyde resins) at elevated temperatures.

It has been discovered that thermosetting resin compositions, formulated without initiators or retardants, provide a particularly well suited base resin material for replacement pipes having long pot-life and can be cured by application of ultrasonic waves. Alternatively, the pot-life of a resin composition used in conventional replacement pipes can be increased significantly by using considerably less, such as less than 50% of a conventional amount of initiator. In a preferred embodiment of the invention, the pot life is extended by encapsulating the catalysts or initiators and releasing these by application of sonic energy.

Cure initiators should be chosen to give the resin a long pot-life and for their chemical sensitivity to ultrasound. Conventional resin formulations for replacement pipes include initiators having activation temperatures in the range of about 40-60°C. However, pot-life can be increased by employing initiators having activation temperatures in the range of 100-200°C and more preferably 100-150°C. The resin should not be heated to the extent that it will begin to degrade. This will enable the replacement pipe liner to be wet out in quality controlled factory conditions and to be safe from curing until activated with ultrasound.

The carrier portion of the resin section preferably has a

fibrous sheet structure including a mat, a web or randomly oriented fibers. The fibers can include glass and/or natural and synthetic fibers and the fibers may be of differing denier. A felt-like mat or web or randomly oriented fibers is particular well suited for storing acceptable quantities of resin so that a wetted out web or mat absorbs a maximum amount of resin. A preferable carrier includes a needled felt of synthetic plastic material fibers which may optionally include filament reinforcement. Other constructions which provide a tube of uncured resin and do not employ a fibrous carrier are also acceptable.

The carrier can be combined with the resin material by charging a quantity of resin into the inside portion of a carrier tube and if necessary, by applying vacuum to the tube to remove air from the carrier. The tube can then be compressed, such as by passing the tube through nip rollers in order to insure even distribution of the resin in the carrier material.

After the flexible resinous pipe is installed in a tubular shape in the pipeline, it is maintained in an expanded condition by application or pressurized fluid, such as water flowing naturally through the existing pipeline or added from an external source. The pipe can include liners on both the interior and exterior sides thereof. The inner liner should be impervious to fluids. It is preferable to ultrasonically cure the resin in the replacement pipe which can be done in the presence of the usual fluid in the conduit.

The method of installing replacement pipe in accordance with the invention can be applied to virtually any situation in which a pipeline, conduit or other passageway is to be repaired. However, the process is best illustrated by describing the rehabilitation of sewer pipelines. Sewer

pipes can vary in diameter from 6 inches to several feet and are normally laid at a gradient with manholes at junctions and bends.

Damage to existing sewer pipelines occurs due to ground movement, chemical attack or age. A soft-liner replacement pipe formed with thermosetting resin material and felt is manufactured, with reinforcement or other composite materials if required, to match the internal dimensions of the existing pipeline. At least the inside of the replacement pipe will include an impervious membrane to seal the replacement pipe during the installation procedure. The replacement pipe is then taken to the installation site and installed by either a pull-in or an inversion method.

The length of existing pipeline to be repaired is cleaned by access through local manholes. The natural flow of liquid through the pipeline is typically bypassed so that installation can be accomplished in an empty pipe. However, this is not always practical or acceptable and installation methods in which the naturally flowing fluid is the inverting medium in accordance with the invention are advantageous when this cannot be accomplished.

When the resin admixed with the cross-linking monomer, catalyst and promoter are in contact or the temperature is sufficiently elevated, the curing reaction accelerates. Nevertheless, some curing can begin even at low temperatures if these materials are all in contact. However, when the catalyst is isolated as in accordance with the invention, curing will not commence until the catalyst is released from the microcapsules.

The catalyst generally must be one which is not water soluble. When the resin is a polyester, the catalyst can be

in organic peroxide such as MEKP or benzoyl peroxide and is isolated within the microencapsulated particles. Any suitable capsule covering that can be ruptured by application of sonic energy, such as gelatin, can be used to form the microencapsulated particles.

When the resin impregnated carrier is formed into the desired shape for the construction of a rigid resin article or the replacement pipe is inflated within the existing conduit by a fluid, a suitable ultrasonic element is introduced into the fluid and ultrasonic energy is released to create cavitation bubbles throughout the liquid medium during sonication.

Ultrasound is transmitted through the medium by waves which alternately compress and stress the molecular structure of the medium through which the wave passes. This stretching action during the rarefaction cycle of the wave is so powerful that the structure of the liquid medium will be literally torn apart to form microbubbles. During the subsequent collapse of these bubbles in the succeeding compression cycle, extremely high energies are generated inside the bubbles. These involve pressures of hundreds of atmospheres and temperatures of thousands of degrees.

The mechanical and chemical effects of the collapsing bubbles are complex, but the end result can be the rupture of the encapsulation shells and the significant enhancement of chemical activity. This energy releases the microencapsulated catalyst so that the catalyst contacts the resin to initiate cure. The ultrasonic energy may also assist and in combination with the catalyst and any promoters present to accelerate the curing of the resin material.

The ultrasound applied to release the catalyst is generally in the frequency range between about 5 to 500 kHz, and

preferably between about 20 and 100 kHz. The generation of these ultrasound waves is normally by electrically driven transducers employing piezoelectric elements. These piezoelectric elements, such as PZT disks, expand and contract when subjected to reversing electric voltage. The piezoelectric elements can be sandwiched between metallic disks to form transducers which can be tuned to general particular frequencies of ultrasound. A 25kHz transducer immersed in water will transmit an ultrasonic wave at 1450 m/s having a wave length of 5.8 cm for hundreds of meters. If the transducer is positioned in a pipe filled with water, reflections will take place at the pipe walls and complex propagation will take place within the pipe, including guided and standing waves. It can be advantageous to line the walls of the existing pipeline with high density material to enhance the ultrasound curing effectiveness and release of the catalyst.

High power ultrasound can be generated by multiple transducers mounted on a suitable mandrel whereby special cylinders energized by push-pull transducer arrangements. The several kilowatts of power ultrasound requires to rupture the capsules, release the catalyst and induce increased chemical activity can be attained with conventional ultrasound technology.

When the pipe is cured ultrasonically, curing takes place throughout the thickness of the resin. This provides a high quality cure and permits curing to progress down a length of pipe as the ultrasonic cure device is transported through the length of pipe. This leads to less longitudinal tension and stresses within the pipe since it is cured gradually rather than all at once by application of a hot fluid within the length of pipe.

The microcapsules may be produced by mixing the catalysts and the shell material e.g. gelatin in accordance with the methods set forth in U.S. Patents Nos 4,101,501; 4,154,774 and 4,362,566. The catalysts and gelatin may be mixed in a ratio 12 to 1.

The above applies specifically to the aspect of the invention using microencapsulated catalysts, but it is to be mentioned that the information given when in general terms, for example where resins catalysts and other additives are specified, and advantages achieved apply to all aspects of the invention given herein.

In relation to the use of microencapsulated catalyst reference is now made to Figs. 1 to 4.

Fig. 1 is a cross-section of a tubular lining pipe 10 in a flattened condition. Lining pipe 10 includes an inner tube 5, and outer tube 6 with a fibrous felt absorbent carrier 7 impregnated with resin 8 including microencapsulated catalyst dispersed therein.

Referring now to Fig. 1A, a cross section of the lining pipe 10 shown in Fig. 1 is shown in diagrammatic and enlarged scale in Fig. 1A. The inner and outer membranes 5 and 6 are clearly shown, and the fibrous felt is indicated by a number of semi-randomly orientated fibres 7A which as illustrated extend generally in a direction transverse to the membranes 5 and 6. This is due to the process of manufacturing the felt involving needling which means that needles or barbs are punched through fibrous layers in order substantially to align but also to entangle the fibres 7A. Only relatively few fibres are illustrated in order to simplify the illustration.

The resin 8 fills the space between the membranes 5 and 6 as shown, and thoroughly impregnates the felt 7.

Also included within the resin are microcapsules 8A and again only relatively few of these microcapsules are shown but it will be understood that they are extensively and evenly distributed throughout the resin. It should be mentioned at this point that the microcapsules can either be embodied in the resin and dispersed throughout the resin before the resin is applied to the felt 7, or alternatively the microcapsules can be distributed throughout the felt before impregnation with the resin. Indeed in some embodiments it may be possible to embody the microcapsules in the fibres 7A of the felt. This may involve producing the fibres by an extrusion process involving a hollow needle through which the microcapsules are fed. The extrusion process may be in the nature of co-extrusion. All embodiments apply in the present invention and indeed the microcapsules can be variously utilised both in the resin and in the fibres and some microcapsules may be applied to the felt and some may be mixed with the resin before the resin is applied to the felt. The microcapsules may typically be of 0.4 micron diameter.

Howsoever the effect is achieved, the end result is that within the sandwich shown in Fig. 1A, microcapsules are distributed throughout the resin and felt as evenly as possible.

For the purposes of illustration, Fig. 1B has been included, and this shows in greatly enlarged detail a single microcapsule and it will be seen to comprise a core 7B of the appropriate catalyst for the resin 8, and a coating or shell 7C which traps the catalyst 7B until it is to be released as will be explained hereinafter. The shell of coating 7C is of a material which is basically inert to ambient conditions

so that it will not deteriorate or rupture unless acted upon in the manner according to the present invention and as will be described hereinafter. An example of such a substance is gelatin, and in order to prepare the capsules a known method is used involving the mixing of the catalyst 7B and the gelatin 7C. It is preferred that the thickness of the gelatin coating 7C should be such as to minimise the use of the gelatin. In other words, the coating should be as thin as possible whilst performing its indicated function. It has been found that mixing catalyst and gelatin in a ratio of 12 parts catalyst to one part gelatin provides a sufficiently thin yet strong shell or coating 7C for the desired effect to be achieved.

Fig. 1C indicates an arrangement similar to Fig. 1B, but the microcapsule structure is modified in accordance with a further aspect of the invention which will be described hereinafter, and therefore reference will be made hereinafter to this figure.

Referring to Fig. 2A, a supply of lining pipe 10 is delivered to a manhole 15 in a layered condition on a roll 11 or on a pallet, which can include a winching system. Alternatively, lining pipe 10 can be delivered to manhole 15 in a folded pack. An existing pipeline 20 to be relined can have liquid such as water flowing therethrough in the direction of arrow A. If fluids are to continue to flow through existing pipeline 20 during installation of lining pipe 10, pipe 10 should be installed in the direction of fluid flow.

Figs. 2A, 2B and 2C illustrate steps of the pull-in installation method in accordance with an embodiment of the invention. A rope 13 is fed from a leading end 18 of lining pipe 10, down manhole 15, through existing pipeline 20 and out through a downstream manhole 16 where it is pulled by a

takeup winch 12. Lining pipe 10 is then pulled into position between manholes 15 and 16 as shown in Fig. 1B.

At a trailing end 17 of lining pipe 10 a sealing ring 17a is provided for securing pipe 10 in position after insertion into existing pipeline 20. Fluid flowing in the direction of arrow A will inflate lining pipe 10. An inflatable or mechanical valve device 21 is positioned at downstream manhole 16 to control fluid pressure and thereby control the inflation of lining pipe 10. During inflation, fluid will back-up in manhole 15 as the pressure within lining pipe 10 builds up.

Referring to Fig. 2C, after lining pipe 10 is inflated, it is maintained in an expanded tubular shape by application of internal pressure from fluid within pipe 10. Rope 13 can then be used to pull an ultrasonic transducer 25 through replacement pipe 10 to ultrasonically fracture the microencapsulated catalyst particle shells 7A to release the catalysts 7B to cure replacement pipe 10. This yields rigid replacement pipe 10'. It has been found that it is advantageous to pull the ultrasonic transducer through replacement pipe 10 at speed of at least about 1 meter per minute. After cure rigid replacement pipe 10' will be a smooth and shiny structural liner that is resistant to wear and chemical action. The ends of rigid replacement pipe 10' are finished and any necessary lateral connections can be cut, such as by robots.

Fig. 3 illustrates an axial transducer ultrasound device 100 for use with lining pipe 10 in accordance with the invention. Ultrasound device 100 includes an axial transducer having a piezoelectric transducer 103 at each end of a titanium cylinder 104. Transducers 103 are connected to a power source by a power cable 101. Device 100 radiates a uniform

field of ultrasound radially throughout the water within replacement pipe 10 without attenuation and onto and through replacement pipe 10. Replacement pipe 10 will absorb some of the ultrasound energy by chemical reaction and conversion to heat and the remainder will be transmitted. Axial transducer ultrasound device 100 also includes a plurality of guide springs 102 for correctly positioning device 100 within inflated replacement pipe 10.

Much of the energy transmitted by axial transducer ultrasound device 100 is reflected back into the pipe by the density discontinuity at the interface of replacement pipe 10 and existing pipeline 20 and will be added to the primary intensity. Energy levels depend on the pipe diameter and thickness.

A multiple transducer ultrasound device 200 is shown in Fig. 4. Multiple transducer device 200 includes a plurality of ultrasound transducers 201. Multiple transducer device 200 can provide larger power although the field pattern may not be as uniform. Another alternative transducer arrangement is to focus the ultrasound field onto a narrow circumferential band by a profiled axial transducer. This can reduce the energy requirements needed for curing the resin. Suitable devices can be obtained from Martin Wlater Ultraschalltechnik GMBH, Hardtstrasse 13-Postfach 6, Ortsteil Conweiler D-7541 Straubenhardt 5.

In a modified method of activating the microcapsules, there may be two ultrasonic sources which operate at different frequencies. These devices may be pulled through the pipe in sequence, the first serving to rupture the capsules and the second, perhaps running at higher frequency, serving to assist and perhaps accelerate the cure.

Details of the invention will be described more fully in the following examples. These examples are presented for purposes of illustration only and are not intended to be construed in a limiting sense.

The stability and cure time of a polyester resin (Scott Bader Crystic 491) and two initiators (encapsulated benzoyl peroxide and Trigonox 42S) after irradiation by ultrasound generated from a Sonics Systems 20 kHz horn with a 1.94 cm and a 0.70 cm diameter horn tip were evaluated as follows.

25 gram samples of polyester resin provided with varying concentrations of benzoyl peroxide and Trigonox 42S (available from the Akzo Chemical Company) were subjected to ultrasound from the 1.94 cm horn and 0.70 cm horn. The time taken for the resin to gel (gel time) together with the temperature obtained were recorded. The polymerization mechanism is exothermic and the temperature measured was intended to be prior to the occupance of the polymerization exotherm. Other acceptable accelerators and initiators include Perkadox 16, Trigonox 44B and cobalt octoate, available from the Akzo Chemical Company.

Example 1

The effect of the concentration of encapsulated initiator on the gel time of the resin was analyzed and the results are presented below in Table 1.

Table 1

<u>Initiator</u>			<u>Gel time/</u>
<u>Concentration/%w/w</u>	<u>Power/W</u>	<u>Intensity/Wcm⁻²</u>	<u>mins:sec</u>
1	67	23	6:03
2	68	23	5:42
3	71	24	3:07
4	72	24	2:20
5	75	25	2:10
6	79	27	2:15
8	81	27	2:08

Table 1 shows that a steady reduction in gel times were achieved as the concentration of encapsulated benzoyl peroxide was increased from 1 to 4%. Above this concentration, little reduction in gel time was observed. It is believed that when the concentration of encapsulated benzoyl peroxide is increased above about 4%, there is an increase in the resin viscosity which reduces the efficiency at which the cavitation events rupture the initiator capsules.

Example 2

The effects of power dissipated by an ultrasonic horn into the resin and th intensity of the ultrasonic field produced were analyzed below in Table 2.

Table 2

<u>Power/W</u>	<u>Horn Diameter/cm</u>	<u>Intensity/Wcm⁻²</u>	<u>Gel time/mins:sec</u>
72	1.94	24	2:10
49	1.94	17	2:43
25	1.94	9	3:58
7	1.94	2	18:22
21	0.70	171	4:12
14	0.70	114	4:57
4	0.70	32	5:35
0.5	0.70	4	72.16

Example 2 shows a preferred range of ultrasonic field intensity as between about 4Wcm^{-2} and 9Wcm^{-2} . At lesser energies, there was not sufficient energy to rupture the initiator capsules. Above this threshold, the horn diameter becomes an important factor, because the larger tip can irradiate a larger proportion of the sample.

Example 3

The effect of the concentration of a co-initiator (Trigonox 42S) on the gel time of a polyester resin system containing 4% encapsulated benzoyl peroxide was analyzed and the results are presented below in Table 3.

Table 3

Trigonox 42S <u>Concentration/%w/w</u>	<u>Power/W</u>	<u>Intensity/Wcm⁻²</u>	<u>Gel time/ mins:sec</u>
0.0	70	24	2:27
0.5	71	24	2:27
1.0	70	24	2:20
1.5	72	24	2:18
2.0	69	23	2:16
2.5	70	24	2:17
3.0	71	24	2:14
3.5	71	24	2:14
4.0	69	23	2:10
4.5	70	24	2:08
5.0	70	24	2:09
5.5	69	23	2:07
6.0	69	23	2:05

Example 3 shows that the concentration of co-initiator has little effect on the gel time of the resin. Thus, the rate controlling step in the curing reaction is the rate at which the initiator capsules are ruptured by ultrasound. The encapsulated initiator can be used to create localized exotherms caused by the polymerization reaction and thus cause a more thermally stable initiator to become effective and thus increase the degree of polymerization.

The encapsulation of benzoyl peroxide catalyst effectively prevents interaction between the thermally unstable initiator and the resin into which it is incorporated. When cavitation from application of the ultrasonic field ruptures the capsules containing the initiator, the resin system becomes

thermally unstable and begins to cure at ambient temperatures. The application of ultrasound does little to increase the average temperature of the resin system. Rather, the ultrasound releases the catalysts and helps initiate the polymerization reaction, which in turn is exothermic, thus generating heat which leads to the exothermic curing reaction.

Example 4

The gel time of polyester resin initiated by encapsulated benzoyl peroxide at an ultrasound frequency of 20kHz was analyzed and the results are set forth below in Table 4.

Table 4

<u>Power/W</u>	<u>Intensity/Wcm⁻²</u>	<u>Gel time/min:secs</u>
65	57	2:36
37	33	2:51
21	19	2:58
10	9	3:12

Example 5

The gel time of polyester resin initiated by encapsulated benzoyl peroxide at 40kHz was analyzed and the results are set forth below in Table 5.

Table 5

<u>Power/W</u>	<u>Intensity/Wcm⁻²</u>	<u>Gel time/mins:secs</u>
31	39	3:08
16	20	3:39
9	11	4:14
6	8	4:22

As shown in Tables 4 and 5, doubling the frequency of the ultrasonic field from 20kHz to 40kHz had little observable effect on the gel time of the samples. The horns were of different dimensions and differences observed were most likely due to differences in the powers and intensities, rather than the frequency.

In relation to the aspect of the invention relating to the use in/or adjacent the resin of particles such as magnetisable particles which are susceptible to radiation, reference is now made to Figs. 5 to 9 and 1C. The lining pipe 2X in Figs 5 to 7 is similar to that in Fig. 1 and comprises a layer of fibrous material 3X, e.g. polyester or other felt, that is impregnated with polyester resin or other suitable heat-curable substance and which contains magnetizable matter capable of being caused to heat by a magnetic field.

The magnetisable matter will typically be magnetisable particles which are contained in the resin in much the same manner as the microcapsules 8A are contained the resin in the embodiment of the invention shown in Fig. 1A. Indeed magnetisable particles and microencapsulated catalyst may be included in the resin at the same time. The microcapsules and magnetic particles may be contained in the resin and/or in the fibres and in a particular arrangement the magnetisable or other particles may be contained within the microcapsules themselves as shown in Fig. 1C. In this figure the magnetisable particles are indicated by reference M and it will be seen that they are contained both in the catalyst 7B and in the capsule shell 7C.

Where magnetisable or perhaps conductive particles, fibres and filaments are contained in the resin, the purpose of these elements is to cause the generation of heat when the elements are subjected to radiation. With this embodiment of the invention, it may be possible to use a one-component resin system without a catalyst and the heat generated by the elements or particles may be sufficient to effect cure of the resin. As has been indicated herein however, the catalyst may be used in conjunction with these particles especially if

the resin is one which is preferred and which requires a high temperature for initiation of cure. The catalyst may be embodied in microcapsules in which case the generation of heat by the application of the radiation to the particles would be used to break the microencapsulation shells and release the catalyst. It will be appreciated that there are various ways of achieving initiation of the cure of the resin.

To prevent liquid or other extraneous matter from coming into contact with the above constituents of lining 2X, the latter is clad on one or both sides with sheeting 4X that is impermeable to liquid and/or dust, e.g. polyethylene sheeting.

The magnetizable matter is preferably incorporated in the resin (and/or may be incorporated in the fibres) and may consist of particles M of a suitable ferromagnetic material, e.g. iron filings, iron particles or iron oxide powder such as that sold under the name "Bayferrox" by Bayer. Alternatively or additionally, the magnetizable matter may be added to the fibrous material 3X separately from the resin, and/or may be incorporated in one or both cladding sheets 4X, and/or indeed in the shells of the micro capsules as hereinbefore described.

As can be appreciated, the magnetisable material or the like can be adjacent the resin, as opposed to being in it, and this in fact opens up further possibilities for the use of magnetisable strips or coatings adjacent the resin provided that they will heat up to a sufficient degree under the influence of the radiation applied to cure the resin.

After lining 2X has been put in place in pipe 1X in known manner, e.g. as described herein or by eversion, the

magnetizable matter is caused to heat with the aid of the apparatus 10X.

Apparatus 10X comprises a core member 11X to the front end of which is secured a wire or cable 12X for drawing the apparatus along a pipe 1X. From the rear end portion of core member 11X project a set of radial and rearwardly inclined spacer arms 13X supporting at their outer ends an annulus 14X consisting either of a single ring-like electromagnet or of a ring-like arrangement of electromagnets such as to form, in operation, an unbroken annular magnetic field.

The coil(s) of the electromagnet(s) is(are) supplied from the core member 11X with a varying, preferably alternating, current fed along conductors in one or more of arms 13X. The core member 11X is in turn supplied from an external source with current by a conductor associated with the wire or rope 12X. This latter current may be fed directly to the coil(s), if suitable, or, if not, may be appropriately modified by means, not shown, contained in the core member 11X, e.g. to increase the alternations and/or modify the voltage. Such means could for instance include a generator of approx 100 kw - 115 volts DC, and a switching device switching to say 3000 cycles/sec included in the unit in the pipe. Such means being known they will not be described in greater detail here.

Upon the coil(s) being energized, a magnetic field is generated that penetrates the liner 2X through the adjacent sheeting 4X to magnetize the magnetizable matter in the liner. By varying the field at an appropriate rate, as by current alternated at a corresponding rate, the magnetizable matter is activated and caused to heat, thereby heating the heat-curable substance in the liner 2X and causing the latter to harden. The rate at which the field should vary will

depend on a number of parameters, such as the speed at which apparatus 10X travels along pipe 1X and liner 2X, the strength of the field and the distance of the coil(s) from the magnetizable matter.

To ensure even hardening of the liner 2X, the coil(s) is(are) kept equidistant from the latter by skates 15X or the like of non magnetic material arranged at equal intervals around annulus 14X and engaging the adjacent sheeting 4X of liner 2X.

As the action of the magnetic field is substantially unimpeded by liquid or other matter flowing in pipe 1X, the apparatus 10X can be used without having first to stop or interrupt such a flow. Should the pipe have a relatively low diameter, say 200 mm or so, the amount of space available for the flow of liquid could be too restricted. This possible difficulty can be obviated by the rearward inclination of spacer arms 13X, allowing the annulus 14X to be located behind core member 11X and enabling more space to be provided around the latter.

To prevent this rearward shift of annulus 14X from causing apparatus 10X to tilt and become wedged in pipe 1X under the sagging action of the core member 11X, the latter is provided on its forward portion with a further set of radial arms 16X that are fitted at their free ends with skates 17X or the like for engagement with liner 2X. Arms 16X are preferably forwardly inclined so as not to reduce the flow space round core member 11X and provide a better overall weight distribution.

The skates 15X and 17X are preferably adjustable in the radial direction as by being telescopically constructed to enable the apparatus 10X to be adapted to different pipe

sizes. They are furthermore preferably resiliently mounted so that they may adjust, during operation of the apparatus, to any slight diameter variations along liner 2X.

Pipe 1X may be made of some other non-magnetic material e.g. plastic, or be of magnetic material, e.g. iron. In this latter event it would be possible to dispense with the magnetizable matter in liner 2X as the magnetic field created by the electromagnetic means associated with annulus 14X would cause the magnetic material on the inside of the pipe to heat after passing through the liner, the heat generated in the pipe being then transmitted by conduction to the resin in the liner. A similar result can also be achieved with a pipe made of non-magnetic material, internally coated with a layer of magnetizable material.

The apparatus 10X described above is intended for round pipes but can of course be modified to work in non round, e.g. oval, pipes by appropriately modifying the shape of the annulus 14X and by relocating arms 13X and 16X and adapting their length.

When no liquid or other matter is flowing along a pipe having to be lined, no or little space need be present between the core member and the coil(s), in which case the coil or coils can be arranged around the core member or annularly within the latter. The apparatus can then work in smaller pipes, or a larger core member can be used.

The apparatus is preferably made fluid-tight, particularly when it is expected to be used in liquid conveying pipes.

Where the apparatus or certain parts thereof is/are in need of cooling during operation, suitable water cooling means may be provided that are supplied with water by a tube associated

with the wire or cable 12X.

The apparatus may of course be modified in a number of other ways to suit particular conditions of operation.

By trial and error and appropriate testing the following can be established:

1. The ideal size of the iron oxide or other particles;
2. The percentage of particles to be incorporated in the resin or fibre;
3. The frequency of the electro-magnetic field (E-M) to be used;
4. The voltage and amperage (power);
5. The distance of the E-M field generators from the impregnated felt;
6. The design and configuration of the field magnets and the generators.

Very recently Scott Bader have produced a crystalline resin additive to produce a thickened pre-preg which is a resin which when first produced is in the nature of a gel and which in due course turns to the consistency of leather, so that it is handlable but sufficiently flexible to be put in position for example when in tube form onto a pipeline or passageway surface. To effect the final cure to rigid form the pre-preg must be subjected to high temperatures e.g. in the order of 110° - 150°C or even higher, but not so high as to cause the resin to decompose. The resin is referred to a pre-preg when it is during its production applied directly to a fibrous

sheet structure or has fibres and/or filaments embedded therein. The use of such a pre-preg presents enormous advantages when used with the magnetisable particles or other magnetisable material. The resin will not finally cure until the high temperature curing is applied, and that can only be created by the application of the radiator to the magnetisable particles.

Particulars of examples of resins suitable for pre-pregs are set forth in the following patent specifications to which reference is made for details UK Patent 2,111,513B; EPA 0271970A; UK 2,221,914A and WO 89?06258 these resins cure temperatures well outside the present means of curing using hot water, and also the pre-preg resins shrink less on curing. Specific resins need about 120 deg C to initiate the curing cycle. Use of pre-preg resins provides long shelf-life. Combining these resins with the electro-magnetic wave heating system provides a new product which is dry, has a long shelf life (about one year) has no styrene problems, and the resin does not flow in the uncured state.

By incorporating the magnetisable particles in the felt fibres prior to felt manufacture ensures even distribution and the felt would be dust free. The fibres may soften at higher temperatures but will set again as they cool. Alternatively or in additionally, one may incorporate carbon fibre and/or filaments which may act as a reinforcement and be susceptible to heating in a similar way to the iron oxide particles. The said fibres and/or filaments may be such as to form current loops to enhance the heating effect. Using this system, with the pre-preg resin system referred to above, provides particular technical advantages as described above.

It is possible in any embodiment of the invention, to reduce

the amount of resin used, to use fillers in the resin up to a quantity of 3 parts filler to 1 part resin. The filler is particulate material and may be aluminium oxide or titanium oxide.

The magnetisable particles or the matter used for the induction heating may be selected or designed to have a low maximum temperature i.e. the temperature at which they lose their property of being susceptible to electro-magnetic induction thus providing a means of preventing the induction particles from over-heating the resin.

As regards estimating or calculating the power needed to effect cure when using the magnetisable particles, the following factors should be taken into consideration;

1. Pipe diameter and wall thickness of felt plus resin.
2. Required temperature minus ambient temperature = required increase in heat of felt etc.
3. Percentage of iron oxide in the felt or fibres.
4. Thermal coefficients of felt etc.
5. From above, calculate the amount of heat needed to bring the temperature up to the critical curing level.
6. Estimate the electric current needed to achieve the required heating effect.
7. As the transmitted power of the electro - magnetic field will be inversely proportional to the square of the distance from the magnets to the felt, the controlled location of the magnets may be crucial. It should be noted that the electro

magnets may or may not have metallic core armatures.

8. If the magnets are too close, the electro-magnetic effect will be proportionally higher at the inside of the felt as compared with the outer side. For example, if the felt is 1cm thick and the magnets are 1cm distant, the effect will be $1 \times 1 \vee 2 \times 2$ i.e. 1 to 4. If the magnets are 4 cm distant, the effect will be $4 \times 4 \vee 5 \times 5$ i.e. 16 to 25. Thus the degree is considerably modified if the distance is increased. However, the power requirement will increase. A compromise solution may be the answer.

9. The speed of passage of the heating unit must be suitable for practical application; an estimate is 0.9 to 1.5 metres per minute.

10. From the above, it is possible to estimate the power requirements for the different pipe diameters and felt thicknesses.

11. The power feed preferably is by direct current, from the surface vehicle to a switching unit in the pipe.

12. The switching unit will preferably be designed with a flotation chamber, to give a net low weight when immersed.

13. The exothermic heat generated during the curing cycle must be taken into consideration, once the curing starts.

14. The heat dissipation through the water and to the pipe being lined must also be considered.

15. Thermal sensors may be incorporated in the travelling unit, so that the power being supplied may be modified and the rate of travel adjusted, so as to achieve optimum effect.

One form of the travelling unit is shown in Figs. 9 and 10 is proposed as being composed of an inflatable, semi - rigid double-skin plastic envelope 30X in which are embedded the electro-magnets 32X. The switching unit 34X is located centrally, suspended inside the unit, or it could be external to the inflated unit. The positioning of the draw wires 36X and the power cable 38X is central but may be decided upon after consideration of possible fouling by sewer contents.

The wiring to the electro - magnets is internal, i.e. inside the double skin envelope, for protection and to avoid fouling with sewer contents.

Multiple layers of electro - magnets could be located in the double skin envelope which may be covered with PTFE, offset at an angle to ensure maximum coverage of the pipe being lined. Thus, their form would not be rectangular box, but slightly curved, so as to fit the cylinder in which they are mounted.

The envelope 30X preferably is inflated with low-pressure air, and the switching unit 34X (110volts DC input) converts the DC input to alternating current at a frequency appropriate for feeding to the individual electro-magnets.

The electro-magnets 32X are maintained at controlled distances from the pipe lining material, as the flexibility of the pneumatic housing 30X should permit the electro-magnets 32X to follow the internal surface, even when irregularities are encountered.

If the iron or iron oxide particles are included, loose, in the felt, they may tend to agglomerate, when the electro-magnetic fields are applied and orientate along the lines of

the fields. Incorporating the particles inside the felt fibres may overcome this.

As stated herein the particles may be iron oxide in the resin itself.

When relatively small magnetisable particles are used, it may well be that radiation of high frequency is necessary in order to achieve the heat effect. In this connection it may be more appropriate to use microwave radiation as the radiation source. An appropriate microwave radiation source which can withstand the flowing liquid will therefore be adopted. When larger particles are used, it may be possible to use radiation of lower frequencies.

As concerns the use of microwave radiation, this provides yet another possibility of embodiment of the present invention, because there are known so-called susceptor or receptor materials which are sheet materials used in the packaging industry for the heating of foodstuffs in microwave ovens. Typical of susceptor material used in the packaging industry is disclosed in US Patent No 4641005, which discloses that susceptor sheet material may be provided by vacuum deposition of metallic particles such as aluminium particles on plastics material sheet. The sheet can be laminated with a further sheet to isolate the particles but in effect form a sheet heater which is flexible, and this technology can be adapted for the passageway lining technology the subject of the present invention. The metallic particles can be for example vacuum deposited on the fibrous layer of the lining pipe, or can be embodied in a plastic sheet material which is applied to the lining pipe, but in any event will be subject to activation by a microwave radiation source which as described in the said US Patent 4641005 reaches a high temperature in the order of 200°C when subject to microwave

radiation. It may be necessary to exercise some control on the maximum temperature to which the particles can be heated by the microwave radiation, in order to match the cure temperature of the resin system which is utilised, but there are also existing patents which are designed to prevent run-away heating using susceptor materials.

The plastic sheets incorporating vacuum deposited metallic particles may be used as the liner sheets of the lining pipe as hereinbefore described, and the susceptor material may be at either side of the lining pipe.

A microwave radiation source would then be drawn through the pipeline with the lining pipe in place to activate the susceptor material and thereby to raise the temperature of the susceptor material in order to transfer the heat to the resin system in order to activate same.

As mentioned hereinbefore, plastics material susceptor film is utilised in the packaging industry, and an example of utilisation in the packaging industry is described in US Patent 4890493 which discloses the use of flexible sheet material for the wrapping of foodstuff items to be cooked. The use of the susceptor material in conjunction with a pre-preg type resin as referred herein is a particularly advantageous arrangement in the matter of lining pipelines or passageways.

It will thus be seen that the objects set forth above, among those made apparent from the preceding description, are efficiently attained and, since certain changes may be made in carrying out the above method and in the pipe and apparatus set forth without departing from the spirit and scope of the invention in its various aspects, it is intended that all matter contained in the above description and shown

in the accompanying drawings shall be interpreted as illustrative and not in a limiting sense.

It is also to be understood that the following claims are intended to cover all of the generic and specific features of the invention herein described and all statements of the scope of the invention which, as a matter of language, might be said to fall therebetween.

It is to be further understood that the invention applies to the making of rigid articles other than rigid replacement pipes for underground pipelines and passageways, and also that the various aspects of the invention as disclosed herein can be used together. Thus the resin may include microencapsulated catalyst and other added matter susceptible to radiation, such as the magnetic particles and/or fibres and/or filaments in which magnetic and/or electrical effects can be induced to cause heating of same.

Particularly it is to be understood that in said claims, ingredients or compounds recited in the singular are intended to include compatible mixtures of such ingredients wherever the sense permits.

CLAIMS

1. A resin system including the resin in which is embodied or which has adjacent thereto inert matter which is not affected by ambient conditions such as ambient heat and light, but such matter is susceptible to applied radiation to such an extent to cause curing or commencement of curing of the resin.

2. A resin system according to claim 1, wherein the resin includes micro encapsulated catalyst, the shells or coatings of which form the said inert matter, which can be ruptured by the application of ultrasonic radiation.

3. A resin system according to claim 2, wherein said shells are of gelatin.

4. A resin system according to claim 3, wherein the micro capsules are formed by a process using twelve parts catalyst to one part gelatin to provide that the said shells have a thinness ensuring that they will rupture under ultrasonic radiation.

5. A resin system according to any preceding claim, wherein the inert matter includes material susceptible to electro magnetic radiation.

6. A resin system according to claim 5, wherein the said material comprises magnetisable particles, such as iron oxide particles.

7. A resin system according to claim 6 wherein the resin system includes a fibrous layer embedded therein, and the said particles are included in the fibres.

8. A resin system according to claim 6 or 7, wherein the resin system is of a nature which has a high cure temperature e.g. 110°C and more.

9. A resin system according to any of claims 1 to 6 whereas the resin includes a fibrous layer embedded therein.

10. A tubular structure comprising a layer of absorbent material impregnated with a resin system according to any one of claims 1 to 6.

11. A tubular structure comprising a fibrous layer impregnated with a resin system according to claim 8,

12. A tubular structure according to claim 10 or 11 including an outer layer of impermeable film or coating.

13. A tubular structure according to claim 10, 11 or 12 including an inner layer of impermeable film or coating.

14. A method of lining a pipeline or passageway comprising placing the tubular structure according to claim 10, 11, 12 or 13 on the pipeline or passageway surface to line same, followed by curing the resin by applying to the structure the appropriate activating radiation.

15. A method according to claim 14, wherein the radiation is applied by moving an appropriate radiation generator along the inside of the tubular structure whilst it is held against the pipeline or passageway surface.

16. The method according to claim 15, wherein the method is applied to the lining of an underground pipeline or passageway in which a liquid flows and the liquid is caused to continue to flow through the inside of the tubular

structure whilst the generator is moved along the inside of same.

17. The method according to claim 16, wherein the said liquid serves to hold the tubular structure against the pipeline or passageway.

18. A method of forming a cured resin article, comprising:

providing a quantity of uncured resin material that is in a substantially stable uncured condition at room temperature;

dispersing an effective amount of a microencapsulated catalyst in the resin material for polymerizing the resin, the catalyst being isolated from the resin so that it will not react with and cure the resin while encapsulated;

forming the uncured resin material into a predetermined shape;

applying ultrasonic energy to the shaped resin material having microencapsulated catalyst dispersed therein to rupture the microcapsules and release the catalyst from the microcapsules; and

allowing the resin material to cure and form a rigid resin article.

19. The method of claim 18, wherein the article has a substantially tubular shape and is within an existing conduit to be lined before the tube is cured.

20. The method of claim 19, wherein pressurized liquid is disposed within the tubular article and ultrasonic energy is applied by transporting an ultrasound device through the

liquid along the longitudinal axis of the interior of the tube.

21. The method of claim 18, wherein the ultrasonic energy is applied at a frequency between about 20 to 100 kHz.

22. The method of claim 19, wherein at least one of a second catalyst and a cure initiator is also dispersed in the uncured resin material.

23. The method of claim 19, wherein the encapsulated catalyst includes benzoyl peroxide.

24. The method of claim 19, wherein the encapsulated catalyst is included in an amount of about 1-4% by weight of the resin composition.

25. A replacement pipe product for lining an existing conduit, comprising:

a tube including uncured resin material formulated in a substantially stable uncured condition at room temperature, the resin material having an effective amount of microencapsulated catalyst dispersed therein and chemically isolated from the resin for polymerizing the resin, the microcapsule of a material which will rupture and release the catalyst upon application of ultrasonic energy.

26. The replacement pipe according to claim 25, wherein the pipe includes a layer of absorbent material impregnated with the resin

27. The replacement pipe according to claim 26, wherein the absorbent material is a fibrous layer.

28. The replacement pipe of claim 27, wherein the resin material includes a thermosetting vinyl ester.
29. The replacement pipe of claim 27, wherein the resin includes a polyester resin.
30. The replacement pipe of claim 27, wherein the encapsulated catalyst is water insoluble.
31. The replacement pipe of claim 27, wherein the encapsulated catalyst is an organic peroxide.
32. The replacement pipe of claim 31, wherein the encapsulated catalyst is benzoyl peroxide.
33. The replacement pipe of claim 27, wherein the encapsulated catalyst is benzoyl peroxide, present in an amount of from 1 to 10% by weight of the resin composition.
34. The replacement pipe of claim 32, wherein the encapsulated catalyst is benzoyl peroxide, present in an amount of from 2 to 6% of the resin composition.
35. The replacement pipe of claim 27, wherein the uncured resin material is substantially thermally stable at room temperature before the microcapsules are ruptured.
36. The replacement pipe of claim 27, including a second catalyst which is thermally stable at normal room temperature, but will assist in the polymerization of the resin upon application of heat from an exothermic polymerization reaction initiated by the released encapsulated catalyst.
37. The replacement pipe of claim 27, wherein the resin

material includes an initiator.

38. The replacement pipe of claim 37, wherein the initiator is Trigonox 42S.

39. The replacement pipe of claim 38, wherein the catalyst includes benzoyl peroxide.

40. The replacement pipe of claim 27, including catalysts and initiators selected from the group consisting of benzoyl peroxide, Trigonox 42S, Trigonox 44B and cobalt octate.

41. The replacement pipe of claim 40, wherein the resin is Crystic 491.

42. A method of curing uncured resin having microencapsulated catalyst particles for curing the resin dispersed therein, comprising:

applying a fluid against the uncured resin; and
applying ultrasonic energy to the resin to release the catalyst.

43. A method of curing a heat-curable substance, e.g. a polymer resin, contained in a pipe liner, which comprises heating the substance by subjecting magnetizable matter in or adjacent said substance to a varying, e.g. alternating, magnetic field to cause at least some of said matter to heat, and transferring at least some of the resulting heat to said substance to cure the latter.

44. A method as in claim 43, wherein magnetizable matter is in the liner.

45. A method as in claim 43 or 44, wherein magnetizable

matter is in or on the pipe, adjacent the liner.

46. A method as in any preceding claim 43 to 45, wherein said field is applied over a predetermined width and is progressively moved along the pipe and liner.

47. A method according to any of claims 43 to 46 wherein the resin is a pre-preg type which cures at a high temperature e.g. 110°C or more.

48. Apparatus for curing in a pipe a heat-curable substance, e.g. a polymer resin, contained in a sleeve-like pipe liner, which comprises means arranged to move within and along said pipe and liner for generating a varying, e.g. alternating, magnetic field such as to cause magnetizable matter in or on said pipe or liner to heat and thereby cure by heat transfer said substance.

49. Apparatus as in claim 48, wherein said means include one or more units arranged to be, during operation, adjacent a circumferential band of the inner surface of the liner.

50. Apparatus as in claim 49, wherein said means are borne by a core member, said core member being located substantially centrally in relation to said means and said means being connected to said core member by spacer arms to provide a throughflow passage for liquid and other matter flowing along the pipe and liner.

51. A sleeve-like pipe-liner comprising a heat-curable substance, e.g. a polyester resin, and magnetizable matter capable of being caused to heat by a varying, e.g. alternating, magnetic field to cure said substance.

52. A pipe liner as in claim 50, wherein said magnetizable

matter is contained in the heat-curable substance.

53. A pipe liner as in claim 51 or 52, wherein said heat-curable substance and said magnetizable matter are contained in fibrous material, e.g. polyester felt.

54. A pipe liner according to any of claims 51 to 53 wherein the resin comprises a pre-preg type resin which cures at a high temperature e.g. 110°C or more.

1-5

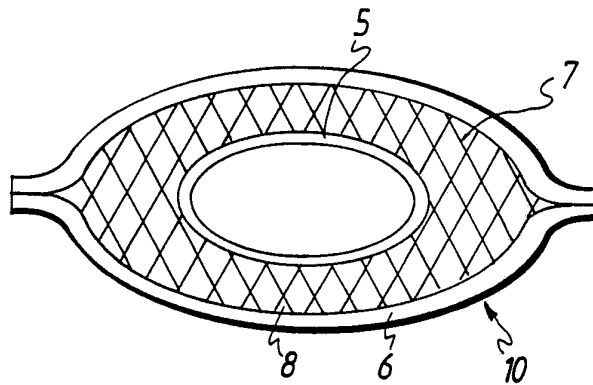

FIG. 1

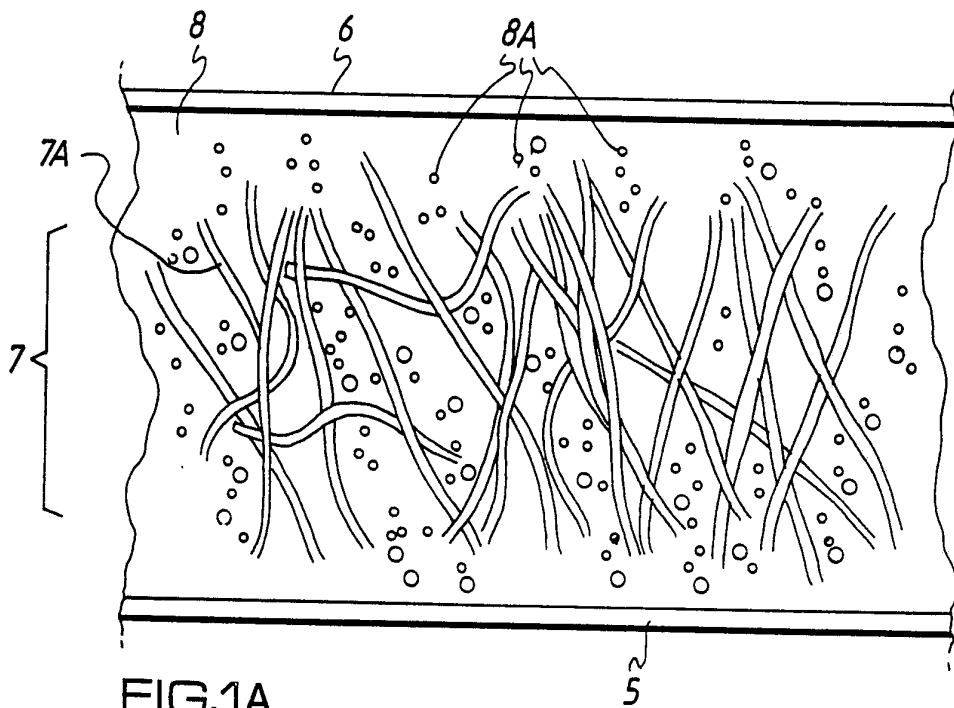

FIG. 1A

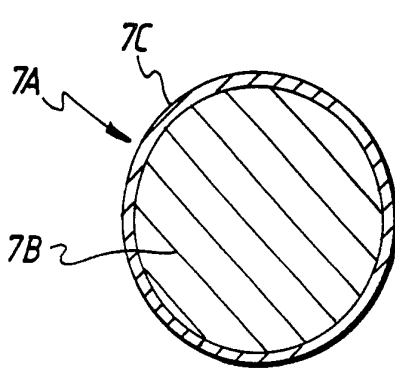

FIG. 1B

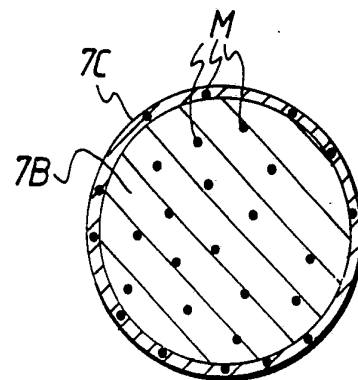
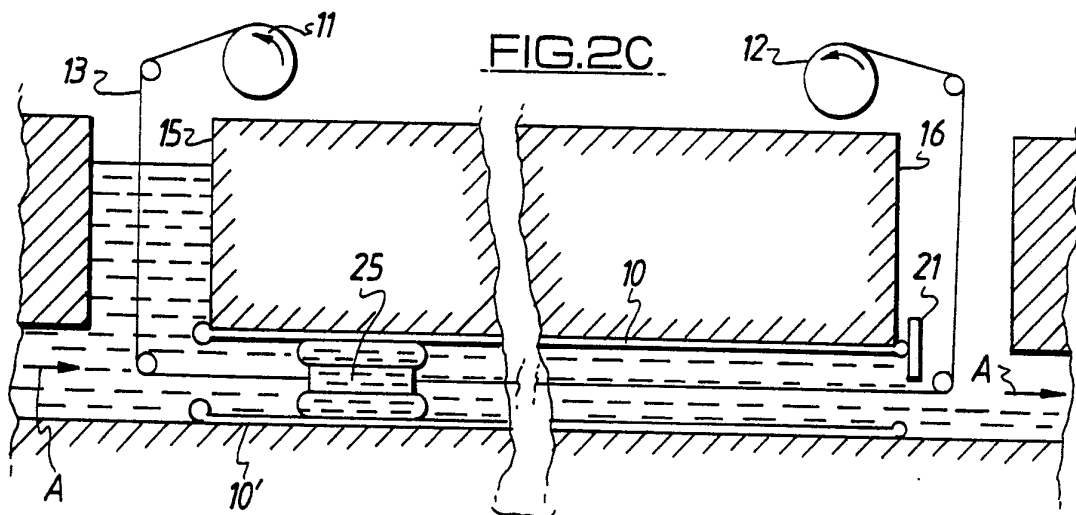
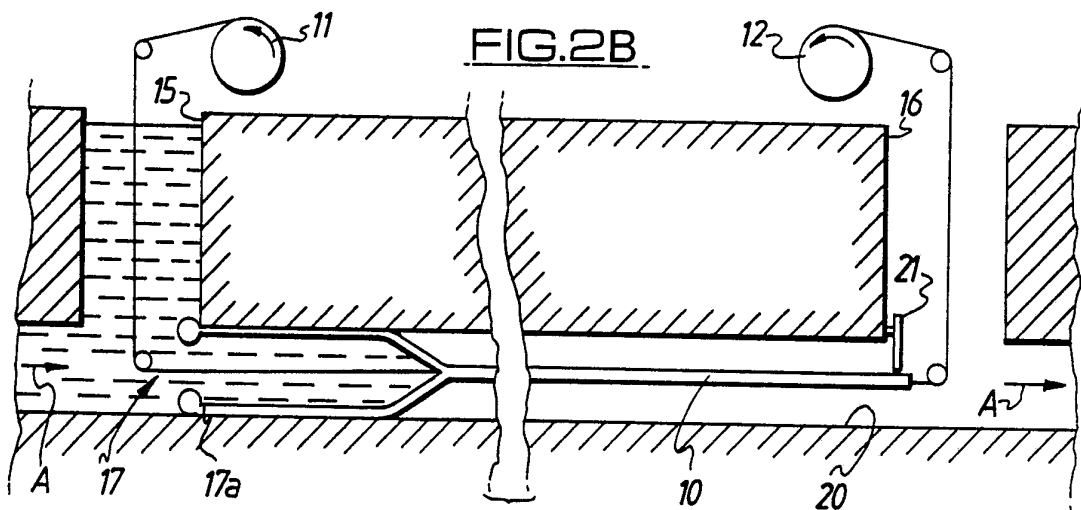
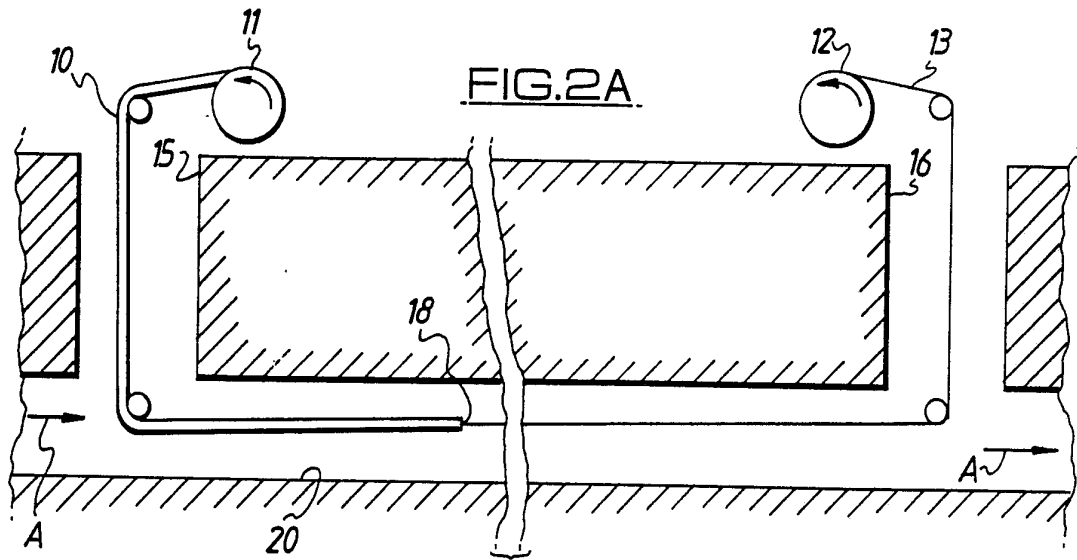

FIG. 1C

2-5



SUBSTITUTE SHEET

3-5

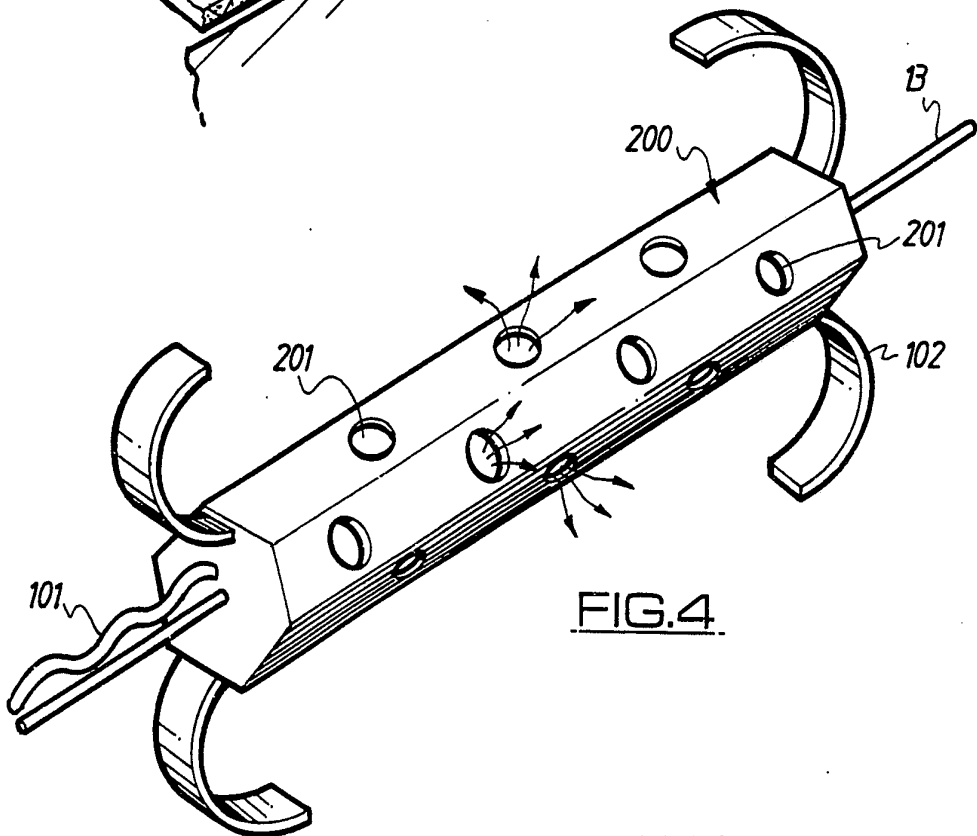
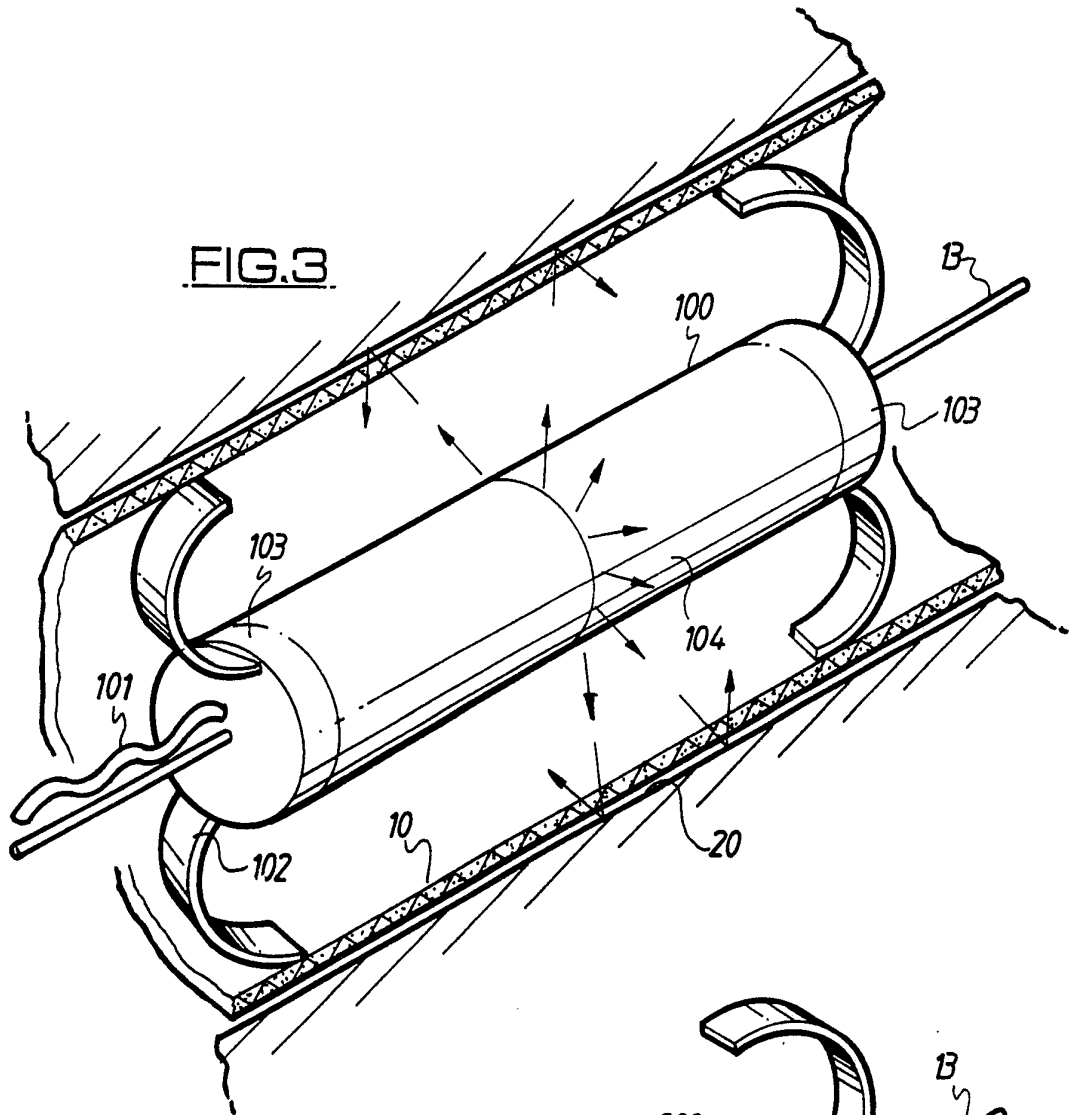

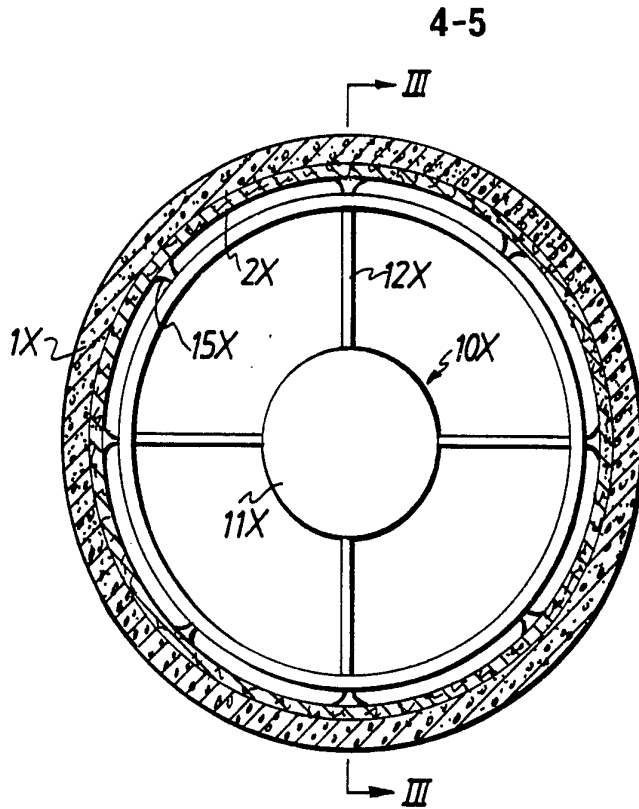

FIG. 5

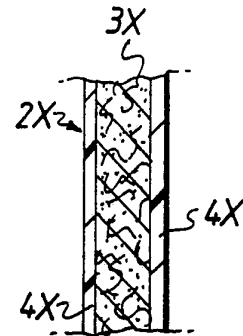

FIG. 6

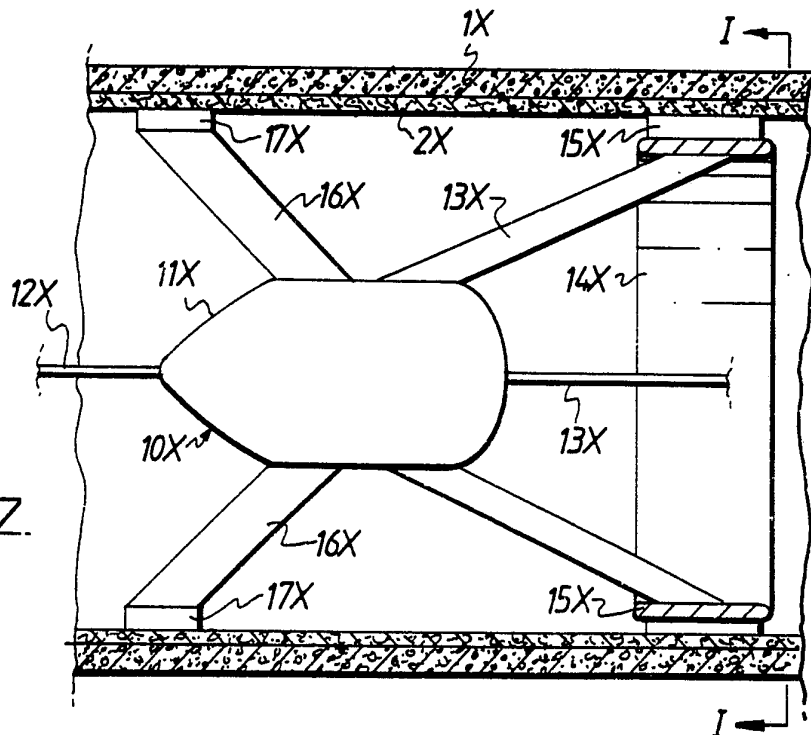

FIG. 7

5-5

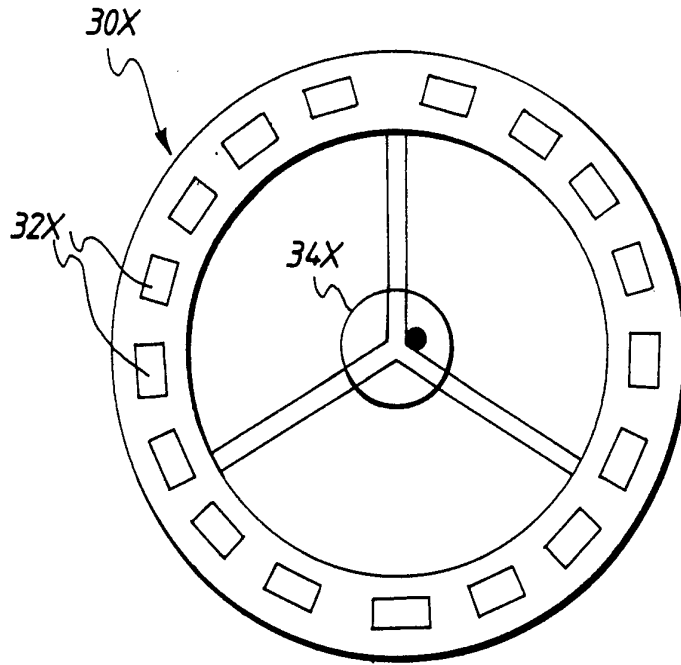

FIG. 8

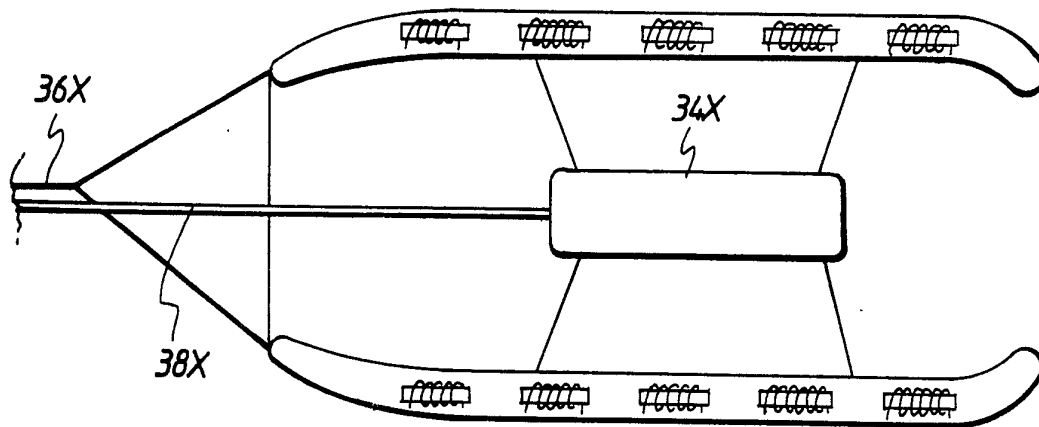

FIG. 9