



INTERNATIONAL APPLICATION PUBLISHED UNDER THE PATENT COOPERATION TREATY (PCT)

<p>(51) International Patent Classification <sup>7</sup> : <b>G06K 11/18, G06F 3/033</b></p>	<p><b>A1</b></p>	<p>(11) International Publication Number: <b>WO 00/25258</b> (43) International Publication Date: 4 May 2000 (04.05.00)</p>
<p>(21) International Application Number: PCT/SE99/01832 (22) International Filing Date: 11 October 1999 (11.10.99) (30) Priority Data: 9803449-9 9 October 1998 (09.10.98) SE (71)(72) Applicant and Inventor: TRULSSON, Christer [SE/SE]; Dalslandsgatan 14, S-464 31 Mellerud (SE). (74) Agents: FORSSÉN, Catarina et al.; AB Stockholms Patentbyrå, Zacco &amp; Bruhn, Box 23101, S-104 35 Stockholm (SE).</p>		<p>(81) Designated States: AE, AL, AM, AT, AU, AZ, BA, BB, BG, BR, BY, CA, CH, CN, CR, CU, CZ, DE, DK, DM, EE, ES, FI, GB, GD, GE, GH, GM, HR, HU, ID, IL, IN, IS, JP, KE, KG, KP, KR, KZ, LC, LK, LR, LS, LT, LU, LV, MA, MD, MG, MK, MN, MW, MX, NO, NZ, PL, PT, RO, RU, SD, SE, SG, SI, SK, SL, TJ, TM, TR, TT, TZ, UA, UG, US, UZ, VN, YU, ZA, ZW, ARIPO patent (GH, GM, KE, LS, MW, SD, SL, SZ, TZ, UG, ZW), Eurasian patent (AM, AZ, BY, KG, KZ, MD, RU, TJ, TM), European patent (AT, BE, CH, CY, DE, DK, ES, FI, FR, GB, GR, IE, IT, LU, MC, NL, PT, SE), OAPI patent (BF, BJ, CF, CG, CI, CM, GA, GN, GW, ML, MR, NE, SN, TD, TG).</p> <p><b>Published</b> <i>With international search report. Before the expiration of the time limit for amending the claims and to be republished in the event of the receipt of amendments. In English translation (filed in Swedish).</i></p>

(54) Title: MANUALLY OPERATED COMPUTER TRACKING DEVICE

(57) Abstract

Hand operating computer input device (1), composed of at least one input control which is characterized by a base portion (2), one to the base portion (2) fixed attached and from said base portion upright handgrip (3), which is arranged at an angle to the base portion. The aim is to place the input device within the width of the shoulder also enabling the hand, arm and shoulder to work in a more natural physiologically correct position.

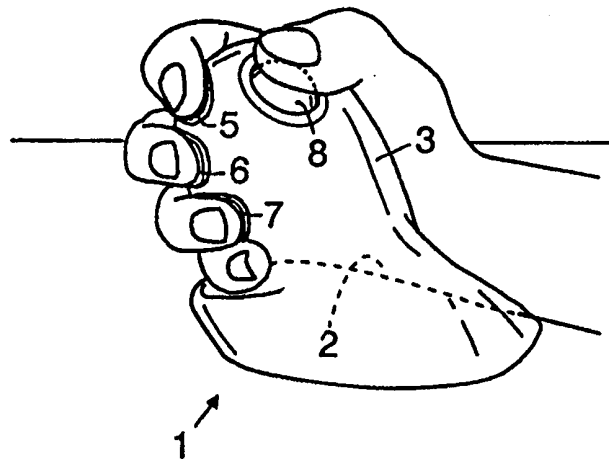

**FOR THE PURPOSES OF INFORMATION ONLY**

Codes used to identify States party to the PCT on the front pages of pamphlets publishing international applications under the PCT.

AL	Albania	ES	Spain	LS	Lesotho	SI	Slovenia
AM	Armenia	FI	Finland	LT	Lithuania	SK	Slovakia
AT	Austria	FR	France	LU	Luxembourg	SN	Senegal
AU	Australia	GA	Gabon	LV	Latvia	SZ	Swaziland
AZ	Azerbaijan	GB	United Kingdom	MC	Monaco	TD	Chad
BA	Bosnia and Herzegovina	GE	Georgia	MD	Republic of Moldova	TG	Togo
BB	Barbados	GH	Ghana	MG	Madagascar	TJ	Tajikistan
BE	Belgium	GN	Guinea	MK	The former Yugoslav Republic of Macedonia	TM	Turkmenistan
BF	Burkina Faso	GR	Greece	ML	Mali	TR	Turkey
BG	Bulgaria	HU	Hungary	MN	Mongolia	TT	Trinidad and Tobago
BJ	Benin	IE	Ireland	MR	Mauritania	UA	Ukraine
BR	Brazil	IL	Israel	MW	Malawi	UG	Uganda
BY	Belarus	IS	Iceland	MX	Mexico	US	United States of America
CA	Canada	IT	Italy	NE	Niger	UZ	Uzbekistan
CF	Central African Republic	JP	Japan	NL	Netherlands	VN	Viet Nam
CG	Congo	KE	Kenya	NO	Norway	YU	Yugoslavia
CH	Switzerland	KG	Kyrgyzstan	NZ	New Zealand	ZW	Zimbabwe
CI	Côte d'Ivoire	KP	Democratic People's Republic of Korea	PL	Poland		
CM	Cameroon	KR	Republic of Korea	PT	Portugal		
CN	China	KZ	Kazakstan	RO	Romania		
CU	Cuba	LC	Saint Lucia	RU	Russian Federation		
CZ	Czech Republic	LI	Liechtenstein	SD	Sudan		
DE	Germany	LK	Sri Lanka	SE	Sweden		
DK	Denmark	LR	Liberia	SG	Singapore		
EE	Estonia						

## Manually operated computer tracking device

5

The present invention relates to manually operated computer tracking device which will make it possible for the computer user to work with the hand, arm and shoulder in a natural position.

### The problem to be solved by the invention

10

On the market today there are a number of different computer tracking devices available. Besides a keyboard, a mouse, ball, pen and pointing plate are used for the input of the information. Generally speaking computer screenwork requires precision and strenuous demands are placed on the user with relation to fine motor co-ordination, as well as stabilising the hand, arm and shoulder. Work is accomplished in a relatively fixed position with many monotonous and repetitive movements of the overarm, elbow, wrist and fingers; the result is static straining of the hand, shoulder including the underarm muscles. Computer tracking devices all have in common that the use of them leads to stress damage of the hand, arm and neck. It has been demonstrated that the positioning of the computer tracking device is of utmost importance. It is to be noted, if not placed in a favourable position relative to the area of movement; it can cause severe outward rotation and abduction of the shoulder. The arm and hand are working in an extreme position; the underarm and hand work in a strained condition.

15

20

Conventional computer mice have the disadvantage that they do not give sufficient support to the entire hand and that the fingers move in a lesser natural way to handle the different function control means. While working with a conventional computer mouse the underarm, together with the hand, is in a flat position (pronation), the fingers are forcibly extended and are moved in a less natural manner. The conventional computer mouse is used in a position, which is often unnatural to the ergonomic desired position; this because a thoroughly inwardly rotated underarm becomes somewhat relaxed when also at the same time the shoulder is moderately rotated outwards and also at the same time extended. During precision work undesirable movements and strain in the extremities become present which can lead to overstraining and its forthcoming effects.

25

30

Documents US 5 648 798 shows an ergonomic computer mouse/steerball with a base and a top portion which can be rotated. By making the upper portion rotatable the computer

mouse can be used by either right or left handed users. The upper portion is arranged at a right angle to the base which gives a twisting and outward rotation of the underarm from its natural position. The idea is to make it possible for the hand to be placed in a neutral position, rest on the support base while using the fingers in a natural manner.

5 Document WO 98/06025 shows a type of mouse which consists of a base section with an upright handle. The idea is that the hand should work in a natural position without static straining of the fingers because the wrist and arm are not being twisted into an unnatural position.

The object of the present invention is to minimise the before mentioned problems  
10 and to make it possible for the hand, over and underarm as well as the shoulder to work nearer their natural position. The invention makes it also possible for the entire hand and wrist to be supported. Furthermore, the underlying idea behind the invention is that the user can work with a grip of the hand where the five fingers in their whole length have complete support and are relaxed. If the tracking device is equipped with function control means they are placed in a  
15 favourable position for the fingers and thumb. This makes it possible for the user to press the function keys with very small movements, known as micromovements.

When a conventional computer mouse is moved there are significant movements required by the hand and wrist. When the tracking device according to the invention has a ball  
20 in the base and functions as a computer mouse, the majority of the movements appear in the elbow and shoulder whereby the hand and wrist are relieved. Furthermore, the invention allows that the rotation of the underarm is neutral, this makes it easier for the shoulder to assume its natural inwardly rotated position. The idea is to place the computer mouse within the width of the shoulders and work with the arm and hand in natural positions.

The object of the computer tracking devices of said type is then the need of a device  
25 which makes it possible for the hand, underarm and overarm as well as the shoulder to work from a more natural position. This need means that the device shall provide support for the wrist as well as the entire hand. As well, the device shall ensure that the wrist, the entire palm and the five fingers in their entire length, are supported in a relaxed position. Further, the device will assure that the underarm rotation is neutral, making it easier for the shoulder to  
30 place itself in its naturally inwardly rotated position. Further the device makes it possible for the hand to locate the proper working position quickly and maintain this position during the work period.

The above requirements are not met by the computer tracking devices as described by the above mentioned documents.

## THE INVENTION

The computer tracking device according to the invention shows a base portion provided with a fixed and at an angle upward directed handgrip portion.

5 The object of the invention is to make a computer tracking device which makes it possible for the hand, under- and overarm, including the shoulder to work in a natural position. The solution according to the invention is characterized by the base and the upwards directed handgrip portion defined in claim 1. The base is provided so that it is a form fitted support for the wrist and the entire hand. The upward directed handgrip portion is provided so that it is support for the wrist, palm and the five fingers in their entire length. The handgrip  
10 portion is angled in relation to the base and has a positioning support which fixes the hand in position so that the rotation of the underarm is neutral and the shoulder places itself in its natural inwardly rotated position.

## DESCRIPTION OF THE DRAWINGS

The invention is described more in detail in the following figures  
15 where:

**Fig. 1** shows a computer tracking device, as seen from the backside which is turned toward the users arm.

**Fig. 2** shows a computer tracking device from the front, i.e. the side on which the fingers rest.

20 **Fig. 3** shows a computer tracking device in a lateral view.

**Fig. 4** shows a computer tracking device in a lateral view opposite the view shown in Fig. 3.

**Fig. 5** shows a computer tracking device as seen diagonally from above.

**Fig. 6** shows a computer tracking device as seen diagonally from behind.

25 **Fig. 7** shows a computer tracking device with a operating control in the form of a ball, as seen from above.

**Fig. 8** shows how the users hand is gripping a computer tracking device; seen from one side.

30 **Fig. 9** shows how the users hand is gripping a computer tracking device; seen from the opposite side shown in Fig. 8.

**Fig. 10** shows a computer tracking device according to fig 9 with a second ball arranged at the bottom of the base.

In the following, the invention is described with reference to the figures. Figures 1-10 show an ergonomic manually operated computer tracking device in different views. The

input device 1 includes a base 2 and a handgrip portion 3. The handgrip portion 3 is arranged fixed to the base 2. The base 2 is ergonomically designed and provides, when the hand is in working position, support for the ulnar side of the hand together with the little finger, by being equipped with a form fitted support 2a, which has a to the hand complementary form.

5 An indentation 2b is provided in the base portion 2, at its backside, in order to relieve pressure from the pisiform- and triquetrum bones.

The handgrip portion 3 is ergonomically designed and gives with the hand in working position support for the wrist, palm and all five fingers. This is accomplished by the handgrip portion 3 being provided upward directed from the base 2 like a club formed  
10 outgrowth 3a. The circumference of the handgrip portion 3 increases with increasing distance from the base 2 and is all over larger than the grip of the hand. The handgrip portion 3 is ended at the top by a rounded part. The hand grabs hold of handgrip portion 3 with all five fingers so that the wrist the palm and the fingers rest against the club like protrusion 3a. To achieve the ideal position where the arm and hand are in a natural position the handgrip  
15 portion 3 is angled in relation to base 2. The longitudinal axis A of the handgrip portion 3 makes an angle  $\alpha$  to the perpendicular of a plane C through the base part (see Fig. 4), where  $\alpha$  is less than  $90^\circ$ .

To ensure that the users hand quickly and easily finds its working position and remains in this position, the handgrip portion 3 is provided with a positioning support 4. The  
20 positioning support 4 is preferably designed as an protrusion 4a which is running like an linear ridge extending longitudinally on the mantle area of the handgrip portion. This ensures that there is no risk that the hand loses its orientation in relation to the tracking device while working. The protrusion 4a is designed in a manner so that it has a bulge formed support, the configuration and location of which fits the fingers proximal interphalanx joints when the  
25 hand grips the handgrip portion 3.

The tracking device can be arranged in two fundamentally different manners. Firstly the tracking device can be firmly built in in a larger part of the computer such as the keyboard. Secondly the tracking device can be independently moveable and function principally like a computer mouse. In the first case the tracking device is fixed. On the  
30 handgrip portion there may be arranged a ball, wheel, keys, pointer or a combination thereof. In the second case the tracking device functions as a computer mouse and has at least a ball or pointer; whether in the base or handgrip portion. When arranged with a ball in the base portion the tracking device is designed so that friction against the underlying surface is minimal.

The computer tracking device according to the invention includes a function control means in the form of at least one of each of the following; ball, roll, wheel, keys, pointer or a combination of the afore mentioned. When the hand grips the tracking device the function control means are so arranged that the fingers alternativ finger tips come in position above the  
5 corresponding function control means.

The functions keys can be accomplished by notching flaps in the base material where the flaps are flexible when touched. The flaps return to their initial position when the touch is finished. Of course, the tracking device may even include conventional function key, roll, wheel or ball. In the example Fig. 9 shows the tracking device provided with flaps 5, 6 and 7  
10 and ball 8. One of the alternatives is shown in fig 10, where the function control means also includes a second ball 8a arranged at the bottom of the base 2.

Generally speaking about the tracking device according to the invention, it has a thickness of material in the area of the flaps so selected, that these flaps yield as might be desired, when depressed. The tracking device can be made in different sizes to accommodate  
15 different size of hands. It is of importance to be able to offer the tracking device according to the invention to children of varying ages. The tracking device may even be produced in a mirror image variant for left handed persons. The tracking device may suitably be manufactured homogeneous with a continuous bridge between the base and the handgrip  
20 portion and being produced from a material that feels cool and nice to the skin, preferably plastic.

-----

### Claims

1. Hand operated computer tracking device (1) including a base portion (2), an upward directed handgrip portion (3), and at least one function control means (5-8), characterized in that the handgrip portion (3) is fixedly arranged upon and at an angle in relation to the base portion (2) and that the base portion (2) includes a form-fitted support (2a) for the ulnar portion of the hand as well as the little finger.

2. The tracking device according to claim 1, characterized in that the handgrip portion (3) is directed upward and includes a positioning support (4) for the hand.

3. The tracking device according to patent claims 1-2 characterized in that the handgrip portion (3) has an overall circumference dimension exceeding that of the grip of the hand.

4. The tracking device according to patent claims 1-3, characterized in that the circumference dimension of the handgrip portion (3) increases as the distance from the base (2) increases.

5. The tracking device according to patent claims 1-4, characterized in that the function control means includes function key, flap, roll, wheel, pointer, ball or combination thereof.

6. The tracking device according to patent claims 1-5, characterized in that an function control means in the form of a bottom roller ball is arranged in the base portion (2).

7. The tracking device according to patent claims 1-6, characterized in that an function control means in the form of a ball or pointer is provided in the handgrip portion.

8. The tracking device according to patent claims 1-7 characterized in that an function control means is a key in the form of a tongue, formed in the basic material.

25 -----

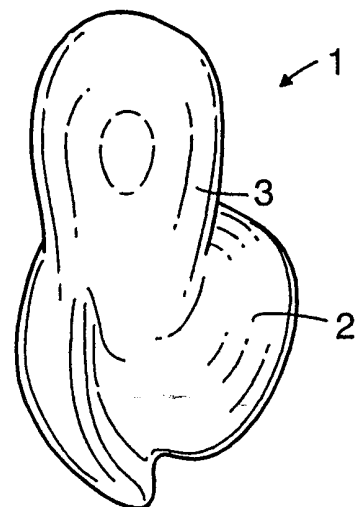
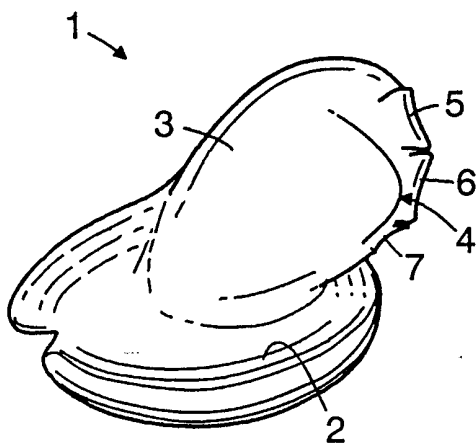
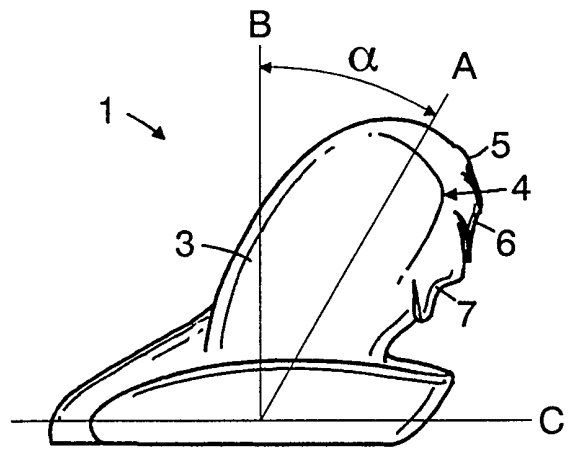
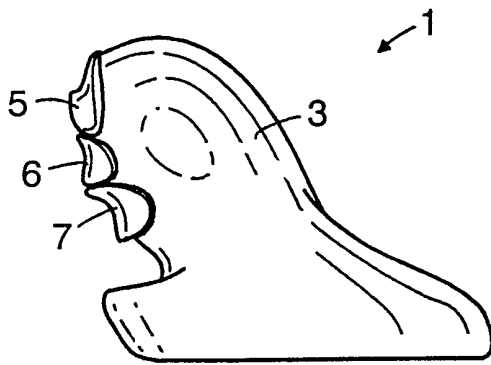
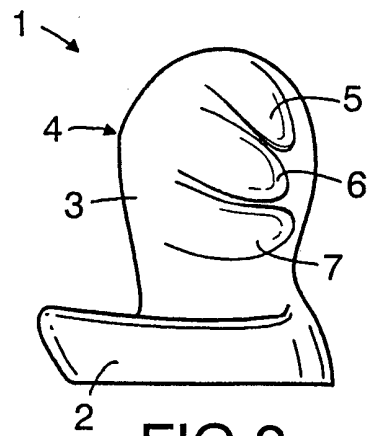
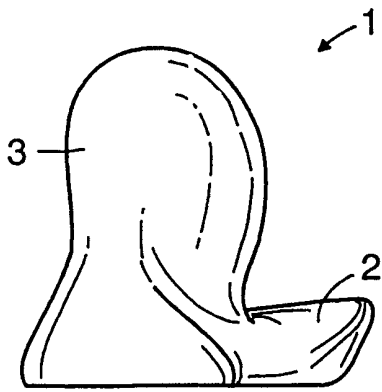

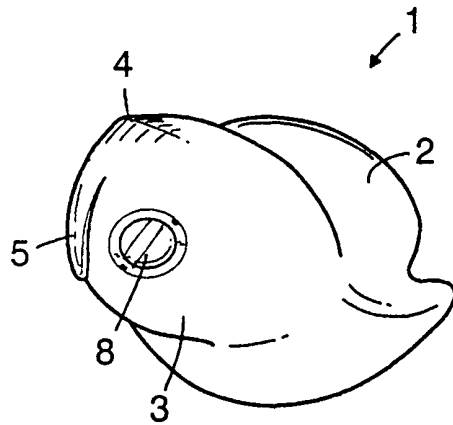

FIG. 7

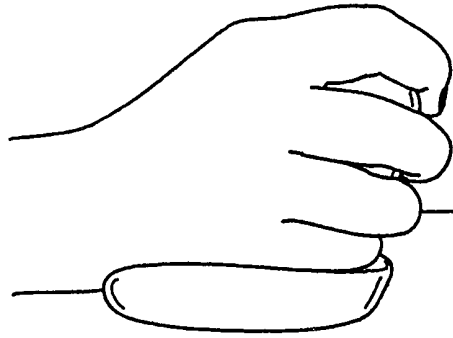

FIG. 8

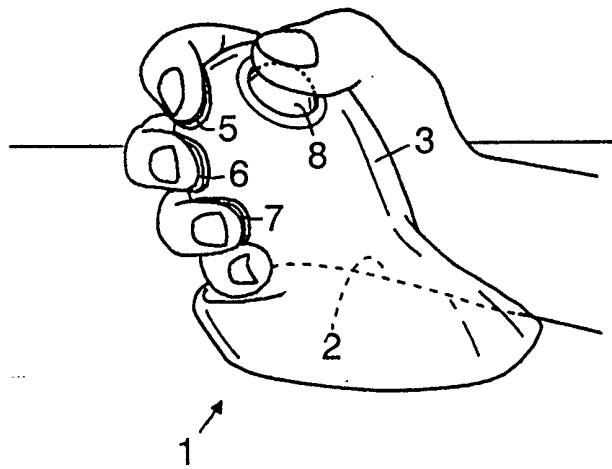

FIG. 9

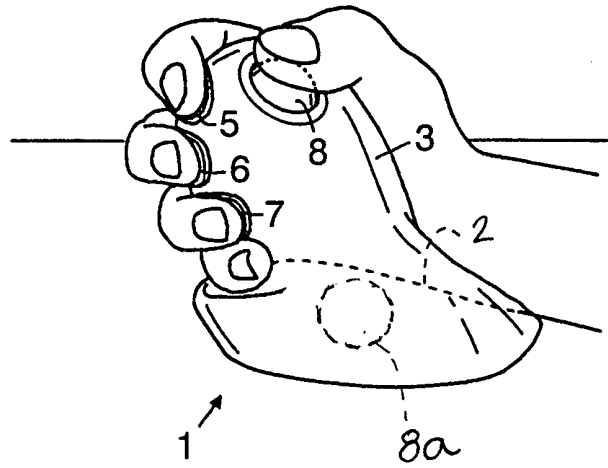

FIG. 10

# INTERNATIONAL SEARCH REPORT

International application No.  
**PCT/SE 99/01832**

## A. CLASSIFICATION OF SUBJECT MATTER

**IPC7: G06K 11/18, G06F 3/033**  
According to International Patent Classification (IPC) or to both national classification and IPC

## B. FIELDS SEARCHED

Minimum documentation searched (classification system followed by classification symbols)

**IPC7: G06K, G06F**

Documentation searched other than minimum documentation to the extent that such documents are included in the fields searched

**SE,DK,FI,NO classes as above**

Electronic data base consulted during the international search (name of data base and, where practicable, search terms used)

## C. DOCUMENTS CONSIDERED TO BE RELEVANT

Category*	Citation of document, with indication, where appropriate, of the relevant passages	Relevant to claim No.
Y	US 5648798 A (DANIEL T. HAMLING), 15 July 1997 (15.07.97), column 3, line 26 - line 48; column 3, line 62 - column 4, line 3, figures 2,4  --	1-8
Y	WO 9806025 A1 (WERGELAND KROG, GABRIEL), 12 February 1998 (12.02.98), page 3, line 8 - line 10; page 3, line 29 - line 32, figures 3a,3b  --	1-8
P,X	WO 9859316 A1 (BERING, CHARLOTTE), 30 December 1998 (30.12.98), page 12, line 8 - page 13, line 35, figure 10  --	1,2,3,4,5,7

Further documents are listed in the continuation of Box C.       See patent family annex.

<p>* Special categories of cited documents:</p> <p>"A" document defining the general state of the art which is not considered to be of particular relevance</p> <p>"B" earlier document but published on or after the international filing date</p> <p>"I" document which may throw doubts on priority claim(s) or which is cited to establish the publication date of another citation or other special reason (as specified)</p> <p>"O" document referring to an oral disclosure, use, exhibition or other means</p> <p>"P" document published prior to the international filing date but later than the priority date claimed</p>	<p>"I" later document published after the international filing date or priority date and not in conflict with the application but cited to understand the principle or theory underlying the invention</p> <p>"X" document of particular relevance: the claimed invention cannot be considered novel or cannot be considered to involve an inventive step when the document is taken alone</p> <p>"Y" document of particular relevance: the claimed invention cannot be considered to involve an inventive step when the document is combined with one or more other such documents, such combination being obvious to a person skilled in the art</p> <p>"&amp;" document member of the same patent family</p>
--	---

Date of the actual completion of the international search <b>21 March 2000</b>	Date of mailing of the international search report <b>29 -03- 2000</b>
---	---

Name and mailing address of the ISA/ Swedish Patent Office Box 5055, S-102 42 STOCKHOLM Facsimile No. +46 8 666 02 86	Authorized officer <b>Nabil Ayoub/cs</b> Telephone No. +46 8 782 25 00
--	--

# INTERNATIONAL SEARCH REPORT

International application No.

PCT/SE 99/01832

C (Continuation). DOCUMENTS CONSIDERED TO BE RELEVANT

Category*	Citation of document, with indication, where appropriate, of the relevant passages	Relevant to claim No.
A	US 5355147 A (DONALD LEAR), 11 October 1994 (11.10.94), column 3, line 12 - column 4, line 27 --	1-8
E,A	US 6005553 A (MARK R. GOLDSTEIN ET AL), 21 December 1999 (21.12.99), see whole document -- -----	1-8

# INTERNATIONAL SEARCH REPORT

Information on patent family members

International application No.

PCT/SE 99/01832

Patent document cited in search report			Publication date	Patent family member(s)	Publication date
US	5648798	A	15/07/97	NONE	
-----					
WO	9806025	A1	12/02/98	AU 2311297 A	25/02/98
				AU 7099696 A	25/02/98
				CZ 9900245 A	14/07/99
				EP 0919022 A	02/06/99
				NO 990442 A	17/03/99
				NZ 333835 A	30/08/99
				PL 331371 A	05/07/99
				WO 9806026 A	12/02/98
-----					
WO	9859316	A1	30/12/98	AU 8012198 A	04/01/99
-----					
US	5355147	A	11/10/94	NONE	
-----					
US	6005553	A	21/12/99	NONE	
-----					