

E. A. HILL.  
BRACKET FOR CAR DOORS.

No. 527,792.

Patented Oct. 23, 1894.

Fig 1.

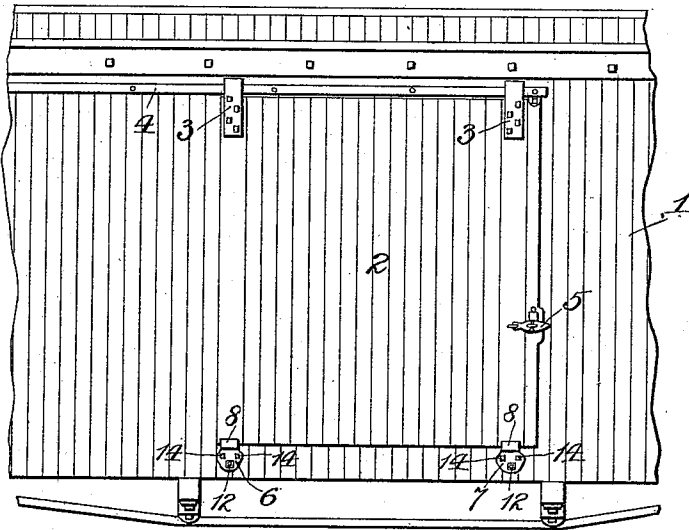

Fig 2.

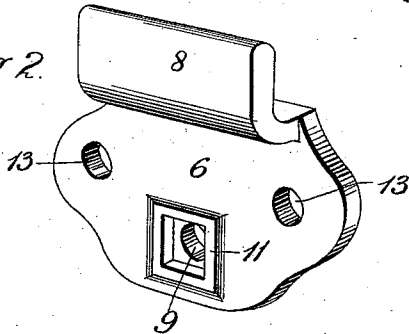

Fig 3.

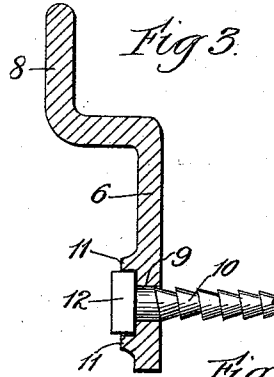

Fig 4.

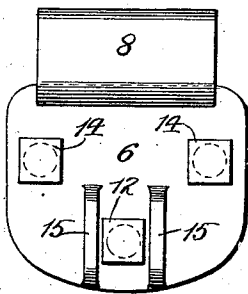

Fig 5.

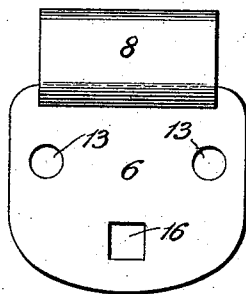

Fig 8.

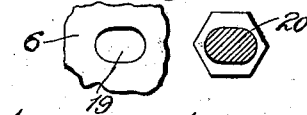

Fig 6.

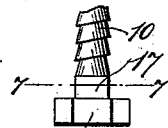
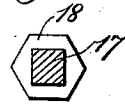

Fig 7.



Witnesses  
*Wm. J. Fleming*  
*Jno. L. Gordon*

Inventor  
*Edward A. Hill*  
 by *Raymond W. Quohun* Attys.

E. A. HILL.  
BRACKET FOR CAR DOORS.

No. 527,792.

Patented Oct. 23, 1894.

Fig 9.

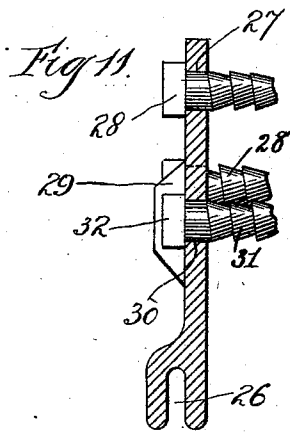
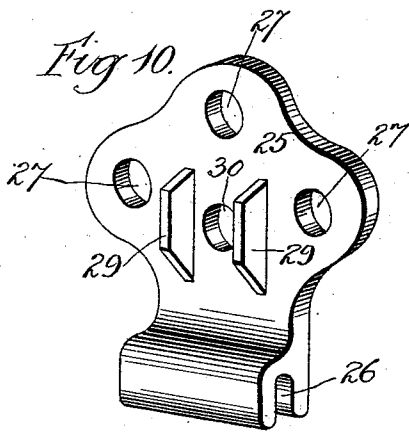
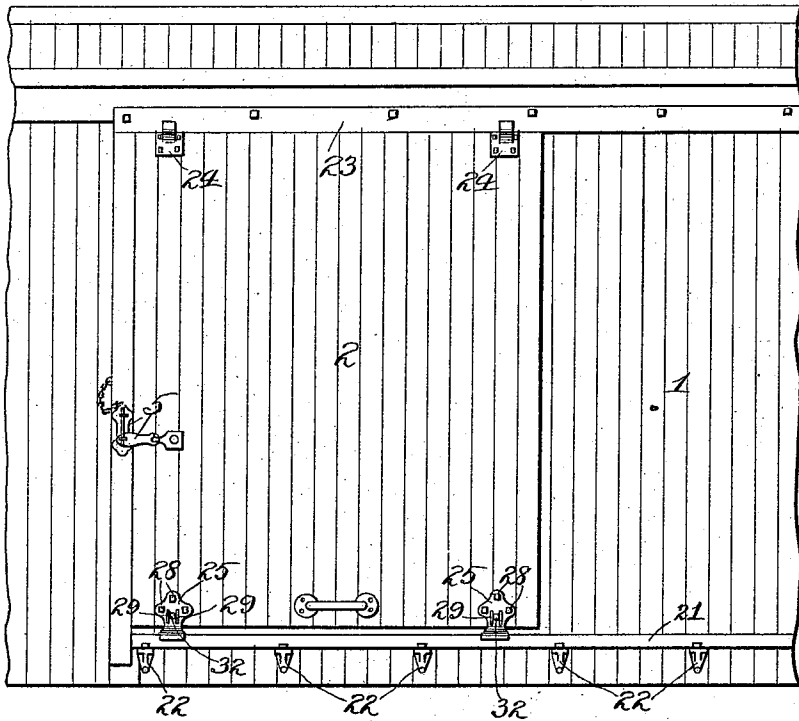

Witnesses  
*Wm. S. Fleming*  
*Jno. L. Condon*

Inventor  
*Edward A. Hill*  
 by *Raymond W. Quinlan*  
 Att'y's

# UNITED STATES PATENT OFFICE.

EDWARD A. HILL, OF CHICAGO, ILLINOIS, ASSIGNOR OF TWO-THIRDS TO  
JAMES L. MALLORY AND EDGAR A. HILL, OF SAME PLACE.

## BRACKET FOR CAR-DOORS.

SPECIFICATION forming part of Letters Patent No. 527,792, dated October 23, 1894.

Application filed February 19, 1894. Serial No. 500,706. (No model.)

*To all whom it may concern:*

Be it known that I, EDWARD A. HILL, a citizen of the United States, and a resident of Chicago, in the county of Cook and State of Illinois, have invented certain new and useful Improvements in Brackets for Car-Doors, of which the following is a full, clear, and exact description, reference being had to the accompanying drawings, forming a part of this specification.

My invention relates to brackets or metal plates which are used in railway equipment for guiding the lower edges of the sliding doors of freight cars so as to properly direct the movement of such doors into and out of closed position. Previous to my invention these brackets or guiding-plates have been used for the double purpose of guiding the doors into and out of closed position and for holding the lower edge of the door when closed, and it has been attempted to prevent surreptitious opening of the doors principally by the use of locks and seals; it being assumed as necessary for a person to break the lock or to rupture the seal in order to obtain entrance into the car for the purpose of removing goods therefrom. It has been found, however, that serious losses of goods by pilfering have been accomplished without either breaking the door locks or rupturing the seals, so that the parties removing the goods have been enabled to escape without detection. This has been accomplished by removing one or more of the brackets or plates from that bottom part of the door-way which is remote from the lock or seal, prying open the adjacent part of the door sufficiently to admit a person's body, the intruder gaining access to the car and passing out the goods through the opening thus made, and the removed bracket being finally replaced after the car door has been closed, so that all traces of surreptitious entrance to the car are concealed until the car has been regularly opened.

Among the primary objects of my invention is included that of producing a bracket which shall effectually guide the sliding door into and out of closed position and which, shall be effectual proof against removal.

A further primary object of my invention

is to produce a bracket which, while performing the functions just mentioned, shall be equally as simple, strong and durable and quite as inexpensive as the brackets heretofore produced.

The above-mentioned objects, as also such others as may appear from the ensuing description, are attained by means of the devices illustrated in the accompanying drawings, in which—

Figure 1 is a side elevation of a part of a box-car having brackets embodying my invention applied thereto; a side door of the car being shown in closed position. Fig. 2 is a detached perspective view of a bracket embodying my invention. Fig. 3 is a central transverse vertical section of the bracket shown in Fig. 2. Figs. 4 and 5 are detached views in front elevation of modified forms of brackets embodying my invention. Figs. 6, 7 and 8 are detached views, in side elevation and in transverse section, of the retaining screws for the brackets. Fig. 9 is an outer side elevation of part of a car-body and its door, showing a modification of my invention applied thereto. Fig. 10 is a detached perspective view of the one of the modified locking devices shown in Fig. 9. Fig. 11 is a central transverse vertical section of the part shown in Fig. 10.

Referring first to the arrangement shown in Figs. 1 to 9, both inclusive, 1 designates the body of a freight car, this being shown as of the box type, and 2 designates one of the side doors of the car, this door being suspended by suitable hangers 3 from a track or rail 4 extending horizontally above the door-opening in the usual or any desirable manner.

5 designates a lock which is applied to the closing edge of the door, and which may be of any suitable or desirable type, preferably such as permits the use of a seal in connection therewith.

I desire to state that while I have shown the door 2 as a side door, it may obviously be an end door of the car, and that while I have shown the body 1 as that of a box car, it may obviously be the body of any suitable type of freight car such as is constructed to inclose the freight which is being transported.

6 and 7 designate the two bracket-guides

for the car-door; these brackets being located in the usual manner, so far as position is concerned, each below and adjacent to one of the lower corners of the door-way and each being  
 5 formed at its upper portion with an outwardly and upwardly extending guide-flange or shoulder 8; these shoulders abutting against the outer side of the lower part of the door and serving to retain the closed door in close  
 10 proximity to the outer side of the car-body. As the car-door is slid into open or closed position, these brackets 6 and 7 serve successively to guide the movement of the lower part of the door so as to insure its proper opening  
 15 and closing.

Previous to my invention, these brackets have been secured to the car-bodies simply by screws or bolts, inserted through suitable openings in the brackets and into the body  
 20 of the car. When it has been desired by mischievous persons to enter the cars for unlawful purposes, it has simply been necessary for such persons to remove the screws from the bracket 6, which is remote from the locked  
 25 edge of the door, thus enabling them to readily remove the shoe and to spring or pry open the door sufficiently far to permit the ingress of a person's body, this being accomplished without either breaking the lock or rupturing  
 30 the seal applied to the lock. After having entered the car and abstracted such of the contents thereof as they desired, such persons could readily replace the door in its closed position and also replace the bracket  
 35 in its position, thus leaving no apparent trace of their work until the car had been regularly opened and its contents inspected.

In accordance with my invention, I so construct the bracket that after one of its retaining-screws has been partially placed in  
 40 position, it is necessary to rotate the bracket with the screw, after the manner of a wrench, until the screw has been effectively driven home and the bracket secured to its proper  
 45 operative position; the bracket being held in such position by the screw. It is obvious that, in order to remove a plate so secured to the car-body, it is necessary first to rotate  
 50 the plate with the screw, in the opposite direction from that in which it was previously rotated, in order to effect its detachment, and it is also obvious that so long as the car-door extends across such plate and in contact therewith, such reverse rotation of the  
 55 bracket for the purpose of detachment is rendered impossible. I have shown several different forms of construction which embody this essential principal of my invention.

In Figs. 2 and 3, I have shown the body of  
 60 the bracket 6 as formed at the middle of its lower portion with an opening 9 to receive an attaching-screw 10. Upon the outer surface of the bracket 6 and surrounding the opening 9, I have shown a rectangular socket  
 65 or recess formed by raised guard 11. The head 12 of the screw 10 is in this instance of rectangular form and of such dimensions as

to fit closely within the rectangular socket of the bracket. At each end of the body-portion of this bracket I have shown ordinary  
 70 holes 13 for the reception of ordinary attaching-screws or bolts 14. When it is desired to place one of these brackets in position upon a car-body, the screw 10 is first inserted into the opening 9 of the bracket and is screwed  
 75 into place, but to such an extent only as will permit the head 12 of the screw to protrude beyond the rectangular raised portion 11, when the plate is forced flat against the car-body. The plate is now drawn outward or  
 80 forward until the rectangular head 12 is seated in the rectangular socket of the bracket and the latter is then rotated axially with relation to the screw 10, the engagement of the head of the screw with the walls 11 of the  
 85 socket causing the screw to turn with the shoe. This is continued until the screw is driven home or the screw tightly forced into its innermost position; the flange or shoulder 8 at the outer part of the shoe occupying a  
 90 horizontal position. Ordinary screws or bolts 14 are now inserted through the holes 13 in the bracket 6 and the latter is in readiness for use. It will be seen that, when the door is in closed position, even if the two screws  
 95 14 be removed from the bracket, it is impossible to rotate the bracket in the reverse direction from that which resulted in its attachment to the car, and that consequently the plate is locked by the door.  
 100

In Fig. 4, I have shown two parallel vertical ribs 15 as formed upon the outside of the bracket at opposite sides of the opening of the screw 10; the head of the screw, in this instance, being rectangular. It is to be understood that but one rib 15 may be used if preferred and that said rib or ribs may be placed horizontally or obliquely with reference to the hole 9. It is also obvious that the head 12 of the bolt may be polygonal instead of rectangular, if preferred, without departing from the spirit of my invention.  
 105

In Fig. 5, I have shown the body 6 of the bracket as formed simply with a rectangular opening 16 through its lower portion; there being no ribs adjacent to the opening. In this instance the outer end of the shank of the screw 10, adjacent to the head thereof, is formed with a rectangular portion 17 to which the head 18 of the screw is directly united.  
 110 Such a hole as 16 may be polygonal or triangular or it may be elliptical, as at 19 in Fig. 8; the portion 17 of the stem or shank of the screw being polygonal or triangular or elliptical (as at 20 in Fig. 8), and the head 18  
 115 of the screw being in either event polygonal, so as to properly take the wrench for preliminarily starting the screw into position.  
 120

With the modifications in form shown in Figs. 5, 6, 7 and 8, after the screw has been  
 130 preliminarily inserted, the bracket is moved outward until the portion 17 or 20 is embraced by the opening 16 or 19 and the bracket is turned as before until the screw is driven

home. After the door has been closed it will be seen that in either of these forms the action is precisely the same, that is to say, the bracket cannot be turned in the reverse direction so as to be detached even after the screws 14 have been removed.

Referring now to Figs. 9 to 11, both inclusive, I will describe a modification of my invention which, while embodying the same principles of both construction and arrangement as are embodied in the structures above described, also involves a reversal of position and action of certain of the parts. In this instance 2 designates the sliding-door and 1 the car-body contiguous thereto, these parts being of the same structural character as above specified. In this instance, however, the door 2 is not supported upon an overhead rail, as before, but slides upon a rail or bar 21 mounted horizontally adjacent to the sill of the doorway; said rail or bar 21 being shown as supported by suitable brackets 22 or by any suitable devices secured to the lower part of the outer side of the car-body. The top of the door is, in this instance, guided in its movements by a horizontal guide-rail 23 suitably secured, above the door-opening, to the outer side of the car-body; suitable guide-brackets 24 which are secured to the top of the door, engaging beneath the guide-rail 23 and thus insuring the proper guidance of the top of the door. In this embodiment of my invention, bracket-shoes 25 are secured by like devices to those previously described, to the bottom of the door, at the outer side and preferably adjacent to the lower corners of the door; the lower end of each bracket-shoe being bifurcated, as at 26, to freely embrace the rail 21, and thus to properly guide the lower part of the door. In Figs. 9, 10 and 11, the body of the bracket-shoe 25 is shown as formed with holes 27, located at the upper part of the body and serving to receive ordinary attaching-screws or bolts 28; these holes being in all respects the equivalent of the holes 13 previously described.

The outer side of the bracket-shoe 25 is shown as provided with two parallel vertical ribs 29, corresponding to the ribs 15 previously described, and also as provided with a hole 30 corresponding to the hole 9, also previously described; this hole 30 being designed to receive an attaching-screw or bolt 31, corresponding to the screw or bolt 10 previously described, and the ribs 29 normally engaging with the sides of an angular head 32 on the bolt 31 (corresponding to the angular head 12 of the screw or bolt 10).

Obviously, all of the modified forms of at-

taching devices (such as a single rib, or a rectangular enlargement 11 on the body 6, an angular portion 17 on the screw or bolt engaging an angular opening 16 in the body 6, or an elliptical opening 19 and a similar portion 20 on the bolt or screw) are as applicable to the bracket-shoe 25 as to the bracket-guide 6. It is also obvious that the essential action of the bracket-guide 6 and of the bracket-shoe 25 are the same; both guiding the door, the former by engagement with said door and the other by engagement with a guide-rail. In other words, the difference is, as previously stated, merely one of reversal and the bracket-guide 6 cannot be turned and detached so long as the door is in contact with it, while the bracket-shoe cannot be turned and disengaged so long as it is engaged by the guide-rail.

While I have thus described these brackets as applied to freight cars, and although this is the especial use to which it is intended to be primarily applied, I desire it to be distinctly understood that I do not wish to confine myself to such precise application of my invention. The brackets are, in either of their forms, equally applicable to any form of sliding-door or shutter which may be located in an exposed position, and which is intended to close any opening in a structure containing valuables which are liable to be stolen by persons entering the structure through the opening.

It is to be understood that while I have shown and described the attaching member 10 as a screw, it may, in any instance, obviously be a bolt of any usual or desired character.

Having thus described my invention, what I claim as new therein, and desire to secure by Letters Patent, is—

1. The combination with a sliding-door, of a bracket and an attaching-screw or bolt having non-rotative engagement with the bracket; said bracket having movable contact with a part of the structure in such manner as to prevent rotation of the bracket, substantially as set forth.

2. The combination with a sliding-door, of a guide-bracket engaged, and held against rotation by the door and a retaining-screw or bolt having non-rotatable engagement with the bracket, substantially as and for the purpose described.

EDWARD A. HILL.

Witnesses:

JNO. L. CONDRON,  
M. E. SHIELDS.