

March 7, 1944.

E. H. JOHNSON

2,343,557

SAW HORSE

Filed Feb. 27, 1943

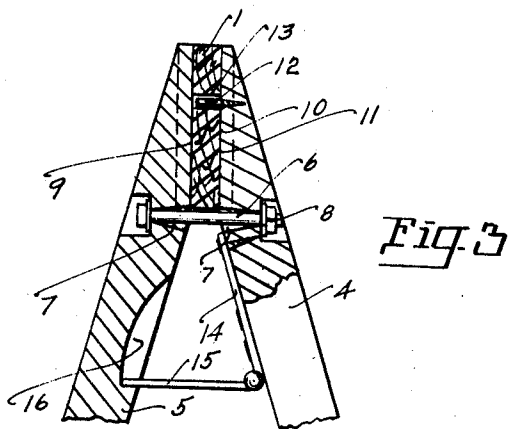
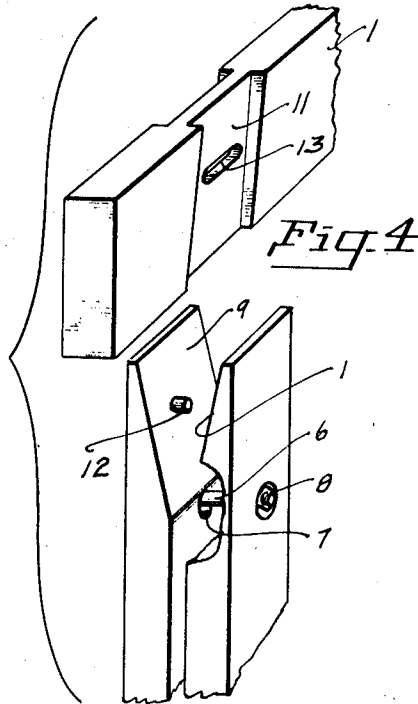
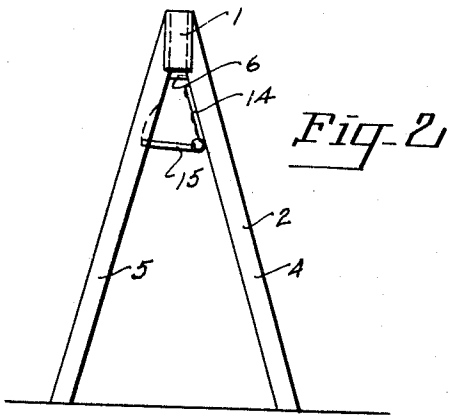
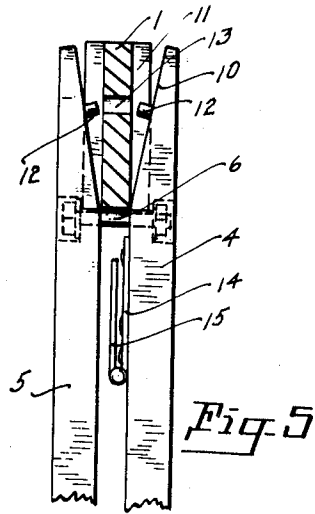
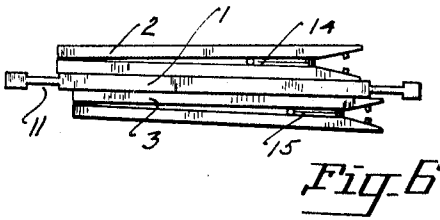
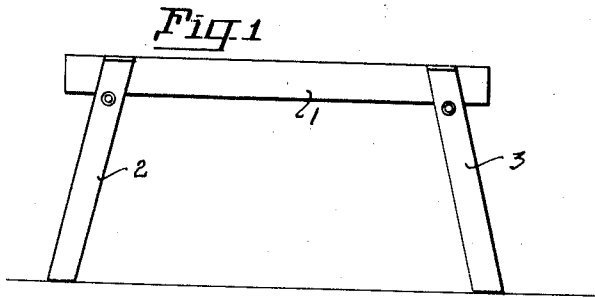

Inventor
Erik H. Johnson
David S. Ferguson
Attorney

UNITED STATES PATENT OFFICE

2,343,557

SAWHORSE

Erik H. Johnson, Portland, Oreg.

Application February 27, 1943, Serial No. 477,366

2 Claims. (Cl. 304—5)

This invention is directed to an improvement in work trestles, particularly of the saw-horse type, wherein the parts are constructed for collapse into a compact and easily transportable or housed package when not desired for use.

The conventional saw-horse is a rigid structure, including a platform strip and legs secured thereto, near each end, and inclined in two directions for bracing purposes. The structure is in this form inconvenient to move from place to place, impossible to store in small compass when not in use, and prohibitive for ready transportation as in street cars or the like from job to job.

The primary object of the invention is the provision of a saw-horse embodying each and every part of the conventional structure, associated with desired strength and rigidity, with such parts so constructed and associated as to permit their relative disconnection when desired for arrangement in a small relative non-bulky package for transportation or storage; the respective parts being formed and constructed to permit simple and easy speedy assemblage into completed form when desired for use.

The invention is illustrated in the accompanying drawing, in which:

Figure 1 is a side elevation of the knock-down saw-horse of this invention, with the parts in assembled relation.

Figure 2 is an end view of the same.

Figure 3 is an enlarged broken vertical sectional view, partly in elevation, showing the connections of the legs.

Figure 4 is a perspective view of a portion of the platform strip and cooperating pair of legs, the parts being shown separated.

Figure 5 is a fragmentary vertical view, partly in section, showing the legs in initial positions for collapsing the structure.

Figure 6 is a plan view of the structure in collapsed and compacted relation.

The improved saw-horse includes a platform strip 1, usually a section of appropriate material of desired length and of greater vertical dimension or height than width, the strip being set on edge to present an upper bearing edge for support of an article. Legs are arranged in pairs at the end of the strip 1, as at 2 and 3, each pair including legs 4 and 5, arranged on the respective sides of the strip 1. The strip 1 is formed near each end and on each side with a recess 11, of uniform depth throughout and extending through the upper and lower edges of the strip. The side walls of the recesses 11 are parallel to

each other, incline downwardly and outwardly toward the proximate end of the strip, and the side walls of the respective recesses on opposite sides of the strip 1 at each end are in alignment.

The legs 4 and 5 of each pair are of identical construction, comprising an appropriate length of material having a width, at least at the upper end, to fit more or less snugly into one of the recesses 11. Each leg at its upper end and throughout a length commensurate with the height of the recess 1, is inclined upwardly and outwardly relative to the outer surface of the leg, as at 9, so that when the leg is seated in the recess 1, with its inclined surface 9 in contact with the bottom of the recess, the leg is inclined outwardly and downwardly from the strip in the desired conventional directions.

The legs 4 and 5 of each pair are united immediately below their upper inclined ends by a bolt 6, passing through transversely aligned holes in the legs of the pair, such holes being countersunk to receive the bolt head and securing nut 8, and being of gradually increasing elongated form inwardly as at 7 to permit relative movement of the legs of a pair on their supporting bolt in the necessary movement of the legs toward and from each other.

The strip 1 within the area of the opposed recesses 11 is formed with an elongated opening 13, and the respective legs 4 and 5 are provided with pins 12 to seat in said opening 13 when the legs are in operative positions on the strip 1, thus serving to rigidly hold the legs when spread in the recesses. A brace member 14 is secured to the inner side of one leg of a pair below the platform 1, and is provided with a hinged length 15, which when the legs are in operative position is swung down to seat in a channel 17 in the inner surface of the opposite leg to maintain the leg-spread.

The legs are applied to the platform or sill 1 by swinging the upper ends apart and arranging such upper ends in line with the appropriate recesses 11. The legs are then swung together to seat their upper ends in the recesses, the pins 12 fitting in the opening 13. The brace is then operatively positioned and the legs are rigid with the platform or sill for any and all uses to which the saw-horse may be applied. Of course, it will be apparent that the mounting and arrangement of the pivot bolt 6 will permit the relative movement of the legs.

When not desired for use, the legs are swung together at their lower ends, after displacing the brace, thus removing the upper ends of the legs from the recesses 11, and permitting each pair

of legs as a unit to be separated from the platform or sill. The legs are then arranged, preferably on each side of and in longitudinal contact with the sill, as clearly shown in Figure 6, forming a relative small compact package for storage or transportation.

Each pair of legs remains as a unit through the pivot bolt 6, thus facilitating the application and removal of the legs in a simple and convenient manner when desired. Of course, any material, size and form of the parts, other than as specifically defined herein, is contemplated.

What is claimed is:

1. A collapsible saw horse, including a platform strip formed adjacent each end and on each side with a recess extending throughout the vertical dimension of the strip and inclined downwardly toward the proximate end of the strip, a pair of supporting legs for each end of the strip, the inner surfaces of the upper portions of the legs being inclined upwardly and outwardly to incline the legs when in position in the recesses, the in-

clined surface of each leg having an inwardly projecting pin to seat in a recess in the strip when the inclined portions of the legs are in contact with the bottom of the recesses, a bolt connecting the legs of a pair immediately below the terminal of the inclined portions of such legs, with said bolt immediately underlying the platform strip when the legs are in operative position relative thereto, the bolt mountings in the legs permitting relative free movement of the legs to provide for collapse and spreading, and a brace carried by one leg of a pair below the bolt, and movable to engage the other leg of the pair to maintain the pins on the inclined faces of the legs in effective cooperation with the slot in the strip.

2. A construction as defined in claim 1, wherein the bolt has countersunk engagement with both legs to prevent obstruction of the bolt beyond the legs when the latter are in operative positions.

ERIK H. JOHNSON.