

(12) STANDARD PATENT
(19) AUSTRALIAN PATENT OFFICE

(11) Application No. **AU 2017204355 B2**

(54) Title
SCAFFOLD FOR ALLOPROSTHETIC COMPOSITE IMPLANT

(51) International Patent Classification(s)
A61F 2/30 (2006.01) **A61B 34/30** (2016.01)
A61B 17/56 (2006.01)

(21) Application No: **2017204355** (22) Date of Filing: **2017.06.27**

(30) Priority Data

(31) Number	(32) Date	(33) Country
62/359,809	2016.07.08	US

(43) Publication Date: **2018.01.25**

(43) Publication Journal Date: **2018.01.25**

(44) Accepted Journal Date: **2021.09.09**

(71) Applicant(s)
MAKO Surgical Corp.

(72) Inventor(s)
BONUTTI, Peter M.

(74) Agent / Attorney
IP Gateway Patent and Trade Mark Attorneys Pty Ltd, PO Box 1321, SPRINGWOOD, QLD, 4127, AU

(56) Related Art
US 20030114936 A1
US 20030236573 A1
US 2002/0007294 A1
US 2002/0029045 A1

ABSTRACT

An alloprosthetic composite implant is disclosed comprising a structural porous scaffold having a pore density profile corresponding to a density profile of bone to be replaced. A plurality of cells including osteoblasts and/or stem cells, are seeded within pores of the porous scaffold and grown by incubation. Further one or more cartilage layers may be grown on top of the scaffold. The pore density profile of the scaffold that is formed may be based on the bone density profile of the bone to be removed, and/or the bone density profile of the native bone that will be in contact with the alloprosthetic implant. A robot may be employed to resect the native bone and also to shape the alloprosthetic implant to fit into place in the native bone.

Figure for publication 7

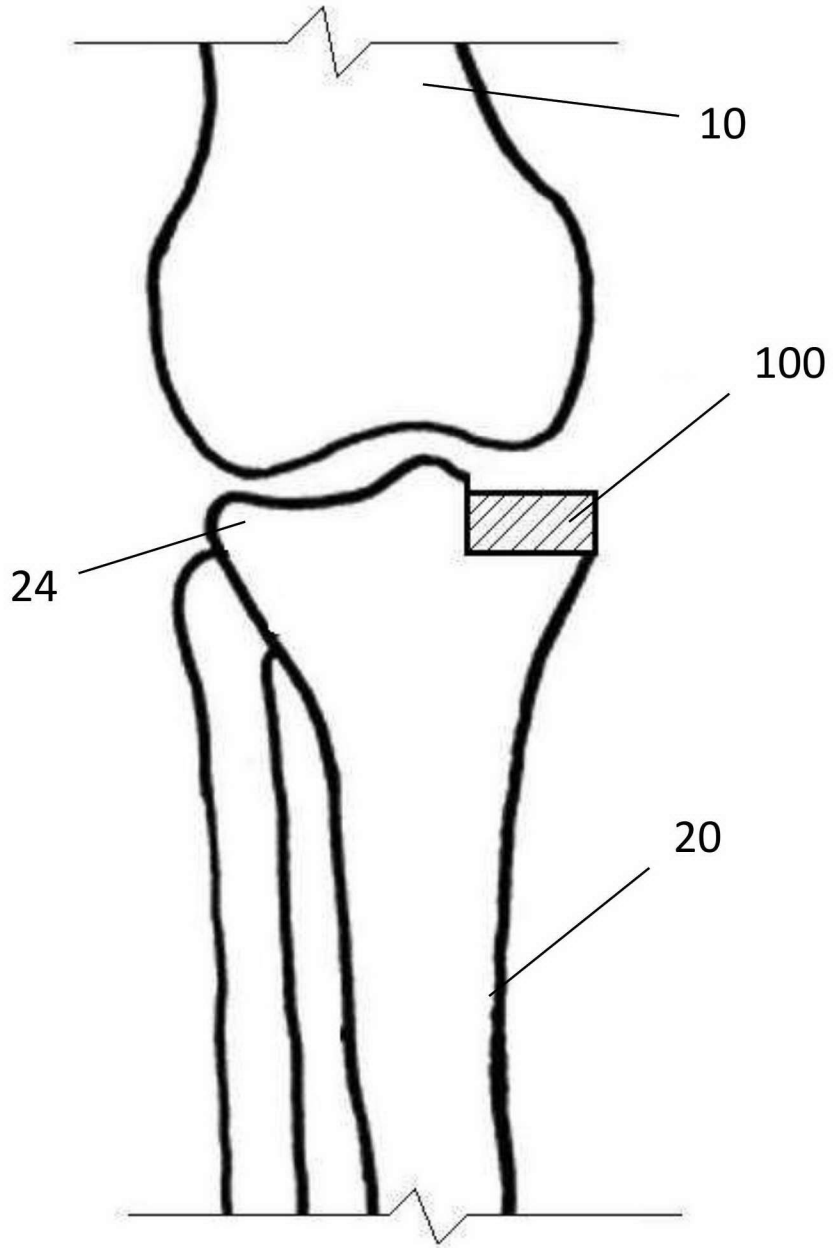

FIG. 3

SCAFFOLD FOR ALLOPROSTHETIC COMPOSITE IMPLANT

CROSS REFERENCE TO RELATED APPLICATIONS

[0001] This application claims the benefit of the filing date of U.S. Provisional Patent Application No. 62/359,809, filed July 8, 2016 and titled “Scaffold for Alloprosthetic Composite Implant.”

DEFINITION

[0002] In the specification the term “comprising” shall be understood to have a broad meaning similar to the term “including” and will be understood to imply the inclusion of a stated integer or step or group of integers or steps but not the exclusion of any other integer or step or group of integers or steps. This definition also applies to variations on the term “comprising” such as “comprise” and “comprises”.

BACKGROUND

[0003] Joint replacement, particularly articulating joint replacement, is a known procedure in orthopedic surgery. However, the ideal material for replacement joints remains elusive. Typically, joint reconstruction involves repair of a bony defect, articular cartilage and in some cases, other tissue such as one or more joining ligaments. For example, in a typical knee arthroplasty procedure, damaged or otherwise deficient cartilage may be removed from the patient along with a portion of subchondral bone. A prosthetic knee implant is implanted into the knee, typically with a metallic portion providing structural support and a plastic component coupled to the metallic portion to provide a bearing surface for articulation with respect to another implant or native tissue.

[0004] The goal of a joint arthroplasty is generally to restore functionality to the joint in a way that closely mimics a healthy native joint. Metal and plastic implant may have a number of benefits, for example, ease and accuracy of production.

SUMMARY OF THE DISCLOSURE

[0005] Applicant has recognized that it would be beneficial to provide implants, articular or otherwise, that are at least partially formed of biologic components to more closely mimic the tissue being replaced.

[0006] According to one aspect of the disclosure, a method of implanting an alloprosthetic composite implant including an implant scaffold comprises: determining a bone density profile of a bone of a patient to be contacted by the scaffold; forming the scaffold to have a pore density profile, wherein the pore density profile of the scaffold is formed based on the determined bone density profile of the bone of the patient; seeding a plurality of viable cells into the scaffold; and incubating the scaffold including the plurality of viable cells to grow bone throughout the scaffold.

[0007] After growing the bone throughout the scaffold, at least one layer of cartilage is grown on top of the grown bone to produce the alloprosthetic composite implant having a first shape; and native bone of the patient is robotically resected to have a particular geometry. After growing the at least one layer of cartilage on top of the grown bone, the alloprosthetic composite implant having the first shape is fixed to a stand, and the alloprosthetic composite implant is intraoperatively robotically machined from the first shape into a second shape corresponding to the particular geometry while the alloprosthetic implant is fixed to the stand, the second shape being different than the first shape.

[0008] The alloprosthetic composite implant having the second shape is implanted into the patient adjacent the resected native bone of the patient.

[0009] A portion of the scaffold intended to contact the native bone is thereby formed with a pore density profile based on the determined bone density profile of the bone of the patient to be contacted by the scaffold.

[0010] The step of forming the scaffold may be performed by additive manufacturing, such as 3-D printing.

[0011] The step of seeding a plurality of viable cells into the scaffold may include seeding osteoblasts and/or pluripotent cells into the scaffold.

[0012] A first inner layer of cartilage may be formed on the scaffold, and a second layer of cartilage may be formed on the first layer of cartilage.

[0013] The step of incubating the scaffold may include incubating the scaffold in a nutrient rich medium.

[0014] The step of robotically resecting native bone of the patient may include forming a first interlocking shape in the native bone and the step of robotically machining the alloprosthetic composite implant may include forming a second interlocking shape in the alloprosthetic composite having a complementary shape to the first interlocking shape.

[0015] The alloprosthetic composite implant used in the method may include any one or more of the features of the alloprosthetic composite implant defined in the preceding aspect of the disclosure.

[0016] There is also disclosed herein an alloprosthetic composite implant for replacing a joint includes a structural porous scaffold having a pore density profile corresponding to a density profile of a bone of the joint to be replaced. A plurality of cells is seeded within pores of the porous scaffold. At least one layer of cartilage may be positioned on an end of the scaffold, the layer of cartilage adapted to replace at least a portion of a joint surface of the joint.

[0017] The density profile of the porous scaffold may include a relatively low density inner portion adapted to contact native bone of a patient, and a relatively high density outer portion opposite the inner portion.

[0018] The porous scaffold may be formed from at least one of metal and collagen.

[0019] The cells seeded within pores of the porous scaffold may be selected from the group consisting of stem cells and osteoblasts.

[0020] The at least one layer of cartilage may include an outer gliding layer of cartilage and an inner layer of cartilage underneath the outer gliding layer.

[0021] The pore density of a portion of the scaffold configured to contact a native bone of a patient may be formed to correspond to a bone density of the native bone to be contacted.

BRIEF DESCRIPTION OF THE DRAWINGS

[0022] Fig. 1 is a highly schematic view of the bones of a knee joint.

[0023] Fig. 2 is a highly schematic view of the bones of a knee joint during a unicondylar knee replacement.

[0024] Fig. 3 is a highly schematic view of a prosthesis implanted into the knee joint of Fig. 2.

[0025] Fig. 4A is a perspective view of a scaffold of the prosthesis of Fig. 3.

[0026] Fig. 4B is a cross-section of the scaffold of Fig. 4A taken along the lines 4B-4B of Fig. 4A.

[0027] Fig. 5 is a perspective view of stem cells being introduced to the scaffold of Fig. 4A.

[0028] Fig. 6 is a cross-section of the scaffold of Fig. 4A with bone cells therein.

[0029] Fig. 7 is a cross-section of prosthesis of Fig. 3 with layers of cartilage.

[0030] Fig. 8A is schematic view of a robotic device resecting a bone.

[0031] Fig. 8B is a schematic view of the robotic device of Fig. 8A shaping the prosthetic implant of Fig. 7.

DETAILED DESCRIPTION

[0032] Different options are available for designing a prosthetic implant. For example, implants may be formed completely of metals and/or plastics and/or other non-biologic materials. Alternatively, implants may be formed of biologic materials, which may be, for example, autografts, allografts, and/or xenografts. Such biologic implants may be harvested from a donor and implanted as harvested (or as modified following harvesting). However, when using fresh or frozen osteochondral allograft materials, it can be very difficult to get the patient's bone to grow into the surface of the allograft. Biologic implants may also be grown *ex vivo*. For example, attempts have been made to grow bone and cartilage for later implantation as part of a joint arthroplasty or other joint repair procedure. Other implants may attempt to combine non-biologic implants with biological components. One example of this is metallic implants that have a porous surface to allow the patient's bone to grow into the metallic portion *in vivo* on a first side of the implant, with a metallic or plastic bearing surface on a second side to provide an articular surface for the prosthetic joint.

[0033] The disclosure provided herein is generally directed to an alloprosthetic composite ("APC") implant, including a scaffold used in the implant. Although the disclosure is directed generally to a specific example of a tibial implant, it should be understood that the concepts provided herein may be applied to other APC implants, which are described in greater detail below. One example of an application of the APC implant described herein is a unicondylar or partial knee replacement. For example, Fig. 1 shows a highly schematic drawing of a knee joint including the distal portion of a femur 10 and the proximal portion of a tibia 20. The distal femur 10 includes a medial femoral condyle which articulates against a medial tibial condyle 22 and a lateral femoral condyle which articulates against a lateral tibial condyle 24. The distal femur 10 does not articulate directly against bone of the tibia 20, but rather against fibrocartilaginous tissue known as menisci that are positioned on top of the proximal tibia 20. Due to age, disease, trauma, or other causes, one or more of the articular surfaces of the tibia 20 may need to be replaced. For example, in a unicondylar knee replace, one of the tibial or femoral condyles may be replaced with a prosthetic implant. Although a unicondylar knee replacement may include replacement of both medial condyles of the femur 10 and tibia 20 (or both lateral condyles), the procedure for simplicity is described as solely replacement of the medial tibial condyle 22.

[0034] In such a unicondylar knee replacement, at least a portion of the medial tibial condyle 22, including the cartilage and subchondral bone, is removed, for example with a manually controlled or robotically controlled cutting tool, as shown in Fig. 2. Once the tibia 20 is properly prepared, an implant 100, such an APC implant formed according to the disclosure provided below, may be attached to the bone to restore normal or near-normal function to the joint, as shown in Fig. 3. It should be understood that implant 100 in Fig. 3 is represented as a block merely for ease of illustration, and, as explained in greater detail below, would be shaped to correspond to the particular anatomy of the patient as needed.

[0035] Figs. 4A-B are schematic illustrations of a scaffold 200 for use in creating an APC implant 100. In one example, scaffold 200 may be formed of a metallic material, such as titanium, formed into a porous three-dimensional structure. Preferably, scaffold 200 is formed via additive manufacturing, for example via 3D printing. One benefit of forming scaffold 200 via 3D printing is the ability to precisely control the structure, including the porosity, of the scaffold 200. For example, because part of the goal of using APC implant 100 is to mimic the native anatomy, it would be desirable to have at least a portion of scaffold 200 be filled with bone tissue that mimics the variable structure of the native bone. In particular, within a bone such as tibia 20, a transverse cross-section through tibia 20 would show that the outer cortical rim portions of tibia 20 have greater density compared to the center portions of tibia 20 which is generally referred to as cancellous (or spongy or trabecular) bone. It is possible to design scaffold 200 in such a way that bone that grows or is otherwise seeded into scaffold 200 grows in a way that mimics the variable density of the portions of the native bone being replaced by APC implant 100, as described in greater detail below.

[0036] It is possible to map the density of bone, including bone that is to be removed and bone adjacent the bone to be removed. Such a density map can be created by any suitable imaging means. For example, the portion of bone that will be replaced may be scanned and computed tomography used to determine a density profile of the bone. Such a density profile may be created, for example, by analyzing pixel brightness of portions of the scanned bone. It should be understood that other methods, including other imaging modalities, may provide suitable means to create a density map of the bone to be replaced. It should also be understood that it may be desirable to create density maps or profiles of surrounding bone, particularly if the bone being replaced is damaged or otherwise has an abnormal density profile which should not be replicated in APC implant 100.

[0037] Fig. 4A is a schematic illustration of a scaffold 200 of APC implant 100 intended for replacement of a medial tibia condyle 22. It should be understood that although scaffold 200 is illustrated as being rectangular, the actual shape of the scaffold 200 may be dictated by the requirements of the particular anatomy at issue. In the example of scaffold 200, the left side of scaffold 200 as shown in Fig. 4A is intended for placement adjacent the resected center of tibia 20, the bottom of scaffold 200 is intended for placement adjacent the resected bottom surface of medial tibia condyle 22, with the top, front, rear, and right sides of scaffold 200 forming defining the exterior faces of scaffold 200. As noted above, a bone density profile of tibia 20 would illustrate that the outer cortical rim has a relatively high the cartilage adapted to replace at least a portion of a joint surface of the joint density, with the density decreasing toward the center of tibia 20. It should also be understood that certain properties, structural features or voids may be provided in scaffold 200, whether or not each are provided by the imaging and/or modeling of natural anatomy described above. For example, the matrix of scaffold 200 is preferably designed to promote vascularization, such as through the inclusion of continuous channels throughout scaffold 200. Further, certain portions of scaffold 200 may have properties different from surrounding portions of the scaffold 200 to provide for particular functionality. For example, the matrix of scaffold 200 may be rougher, have increased texture, and be more vascular to provide for an enhanced ligament attachment site. This may correspond to natural features, such as bone fibers (or Sharpey's fibers) which may provide for attachment sites to bone. Using data corresponding to the bone density profile of tibia 20, scaffold 200 may be created, for example by 3D printing of titanium, so that the scaffold 200 has porosity that generally corresponds to the density profile of the bone being replaced (or, in the case the bone being replaced has an undesirable density profile, for example due to degeneration, the porosity profile of the scaffold would correspond to a desired density profile). It should be understood that other types of metals, as well as non-metals, including bioabsorbable materials or collagen, may individually or in combination form the scaffold 200. At least some inclusion of collagen in scaffold 200 may be preferable to help promote bone growth in and on the scaffold.

[0038] Fig. 4B shows a cross section of scaffold 200 taken along a longitudinal plane passing through the center of scaffold 200, as represented by line 4B-4B of Fig. 4A. As shown in Fig. 4B, scaffold 200 may include a variety of porosity zones 210, 220, 230 that generally correspond to the desired density profile of APC implant 100. In the illustrated example, porosity zone 210 may have relatively low porosity corresponding to relatively high density of cortical bone. Porosity zone 230 may have relatively high porosity

corresponding to relatively low density of cancellous bone, with porosity zone 220 being intermediate. The amount of porosity may be determined, for example, by the amount of spacing between the metal, which may take a foam or lattice type of configuration. It should be understood that scaffold 200 need not include discrete porosity zones, but rather may include a gradient of porosities that correspond to the desired bone density of APC implant 100. Further, it should be understood that the shape of any porosity zones need not be rectangular or any other rigid shape, but may be dictated by the corresponding shapes of the desired bone density profile.

[0039] As shown in Fig. 5, stem cells 300 may be introduced or seeded into and/or onto scaffold 300. The harvesting and seeding of cells may be done by any suitable means, some of which are described in greater detail in U.S. Patent No. 7,299,805, the contents of which are hereby incorporated by reference herein. For example, the cells used may be any suitable type of viable cells, preferably those that correspond to the native tissue being replaced. This may include, for example, chondrocytes (and/or chondroblasts), osteoblasts, fibroblasts, and/or pluripotent cells or stem cells. Stem cells may be harvested, for example, from bone marrow or fetal cells. Although cells 300 are generally referred to as stem cells herein, it should be understood that any suitable type of cell or combination of cell types may be alternately used. Upon introduction into scaffold 200, stem cells 300 migrate through the scaffold 200, attaching to the metal that provides the structure of scaffold 200, with the stem cells 300 differentiating into bone cells over time. The attachment may be affected and controlled, for example, by the texture of the surface of scaffold 200 and the size of the pores within the scaffold 200. The use of collagen, as well as adding calcium and controlling the pH balance of the scaffold system may help promote bone growth. The differentiation into the desired cell type or types may be controlled, for example, by applying or exposing the cells to certain environmental conditions such as mechanical forces (static or dynamic), chemical stimuli (*e.g.* pH), and/or electromagnetic stimuli.

[0040] With the stem cells seeded into scaffold 200, the scaffold 200 may be placed inside an incubator. The incubator may include a nutrient rich medium that is flowed through the scaffold 200 to provide a desirable environment for the cells in the scaffold. The bone cells may grow and migrate through scaffold 200, with the bone growing more densely in the zones with low scaffold porosity, such as porosity zone 210, and less densely in the zones with high scaffold porosity, such as porosity zone 230, as shown in Fig. 6.

[0041] After the seeded bone cells have migrated and grown into scaffold 200, one or more layers of cartilage 240, 250 may then be grown on top of the bone. For example, a first

deep layer 240 of cartilage may be grown on top of the relatively dense bone in porosity zone 210, and a gliding layer 250 may be grown on top of the deep layer 240. Gliding layer 250 may provide a surface for articulation with a bone of a corresponding joint, such as a femoral condyle. The growth of the cartilage layers 240, 250 may also be assisted with the use of an incubator, with the cartilage growth taking place over a period of up to eight weeks, for example. The differentiation between cartilage layers 240, 250 may be based, at least in part, on difference within the scaffold 200 upon which the cartilage grows. Although the cells are described as being seeded and incubated prior to implant, it should be understood that the scaffold 200 may first be implanted into the patient with the cells being seeded into the scaffold 200 intraoperatively.

[0042] The implant 100 with both bone grown throughout the scaffold 200 and cartilage layers 240, 250 grown on top of the bone is shown in Fig. 7. At this point, the implant 100 may be ready or near-ready for implantation. For example, in a unicondylar knee replacement procedure, implant 100 may be provided in the operating room where the knee replacement is to take place. Preferably, the medial tibial condyle 22 is resected according to an operative plan with the use of an autonomous or semi-autonomous robotic system, such as the robotic system described in greater detail in U.S. Patent No. 8,287,522, the disclosure of which is hereby incorporated by reference herein. For example, as shown in Fig. 8A, a robotic device 400 with a robotic arm 410 and a cutting tool end effector 420 may resect medial tibial condyle 22 according to a plan in a computer controlling robotic device 400. Based on the particular geometry of the resected native bone, robotic device 400 may be used to shape implant 100 to have a corresponding fit to the implant site. Implant 100 may be fixed to a stand 430 or other device to secure the implant 100 as the end effector 420 of robotic device 400 customizes the shape of implant 100.

[0043] Once shaped, implant 100 may be press-fit, packed, or otherwise implanted into the implant site. The robotic device 400 may also assist in the step of positioning the implant 100 onto the native bone, for example with the aid of a navigation system and/or sensors to position the implant 100 in the desired three-dimensional position with respect to the tibia 20. Any known type of external hardware, such as fixation screws or pegs, may be used to facilitate the initial connection of the implant 100 to the native anatomy. As noted previously, scaffold 200 preferably includes a density profile that mimics or otherwise corresponds to the bone density profile of the native bone that will be positioned adjacent the implant 100. The native bone will grow into the scaffold 200, with the matching density profiles resulting in better bone ingrowth compared to other implants. For example, it has

been found that, for fresh allograft and frozen osteochondral graft, it is difficult to get native bone to grow into the implant surface. However, bone consistently grows to surface of metallic porous scaffold 200, particularly with its three-dimensional surface. Furthermore, matching density profiles between the native bone and the scaffold 200 further encourages bony ingrowth into the scaffold 200.

[0044] It should be understood that the fabrication of scaffold 200 may be complicated. One alternative option in creating the scaffold is through use of the body's own scaffold as a guide. For example, a user may start with a body portion (*e.g.* a tibia portion of a knee joint) and repeatedly apply aldehyde to remove tissue, bone, hydroxyapatite, and/or selenium material, leaving only collagen and the scaffold behind. The three-dimensional structure and geometry of the remaining cartilage and scaffold can then be mapped. For example, lasers or other suitable devices may scan or otherwise map the scaffold and cartilage and to store the structure in computer memory so that the structure could be easily reproduced, for example via additive manufacturing. Rather than mapping, a negative mold of the scaffold could be created so that the scaffold could be reproduced with the mold. The scaffold could be created from metal as described above, or alternately created directly with tissue. For example, a 3D printer could be used to build a scaffold directly with bone cells and/or collagen without the need to impregnate a metal scaffold with cells. In other embodiments, the scaffold 200 may be produced in a manner described in U.S. Patent No. 8,992,703, the disclosure of which is hereby incorporated by reference herein. For example, the method of forming the three-dimensional scaffold 200 may include building the shape by laser melting powdered titanium and titanium alloys, stainless steel, cobalt chrome alloys, tantalum or niobium using a continuous or pulsed laser beam. Individual layers of metal may be scanned using a laser. The laser may be a continuous wave or pulsed laser beam. Each layer or portion of a layer may be scanned to create a portion of a plurality of predetermined unit cells. Successive layers may be deposited onto previous layers and also may be scanned. The scanning and depositing of successive layers may continue the building process of the predetermined unit cells. Continuing the building process may refer not only to a continuation of a unit cell from a previous layer but also a beginning of a new unit cell as well as the completion of a unit cell.

[0045] Although described above in the context of replacing a joint, and particularly a tibial condyle of a knee joint, the concepts provided above may extend to creating other alloprosthetic composite prostheses. For example, prostheses with scaffolds similar to those described above, with or without cartilage, may be implemented to replace segmental defects

of bone after trauma, for arthrodesis, or for correcting leg length discrepancies. Other potential uses include for spinal fusion, in which the scaffold facilitates the fusion rather than a more typical prosthetic cage device. When used in the spine, the prosthesis may facilitate soft tissue graft, for example to replace the annulus fibrosus and nucleus pulposus with ingrowth into the vertebral endplates. The scaffolds described above could also be used for pure tissue grafts, for example when a rotator cuff is missing. Such an implant could be formed from a tissue scaffold, rather than a metal or bone scaffold, with tissue ingrowth into the tissue scaffold.

[0046] Although the invention herein has been described with reference to particular embodiments, it is to be understood that these embodiments are merely illustrative of the principles and applications of the present invention. It is therefore to be understood that numerous modifications may be made to the illustrative embodiments and that other arrangements may be devised without departing from the spirit and scope of the present invention as defined by the appended claims.

CLAIMS:

1. A method of implanting an alloprosthetic composite implant including an implant scaffold, the method comprising:
 - determining a bone density profile of a bone of a patient to be contacted by the scaffold;
 - forming the scaffold to have a pore density profile, wherein the pore density profile of the scaffold is formed based on the determined bone density profile of the bone of the patient;
 - seeding a plurality of viable cells into the scaffold;
 - incubating the scaffold including the plurality of viable cells to grow bone throughout the scaffold;
 - after growing the bone throughout the scaffold, growing at least one layer of cartilage on top of the grown bone to produce the alloprosthetic composite implant having a first shape;
 - robotically resecting native bone of the patient to have a particular geometry;
 - after growing the at least one layer of cartilage on top of the grown bone, fixing the alloprosthetic composite implant having the first shape to a stand, and intraoperatively robotically machining the alloprosthetic composite implant from the first shape into a second shape corresponding to the particular geometry while the alloprosthetic implant is fixed to the stand, the second shape being different than the first shape; and
 - implanting the alloprosthetic composite implant having the second shape into the patient adjacent the resected native bone of the patient,
 - wherein a portion of the scaffold intended to contact the native bone is formed with a pore density profile based on the determined bone density profile of the bone of the patient to be contacted by the scaffold.

2. The method of claim 1, wherein the step of forming the scaffold is performed by additive manufacturing.

3. The method of claim 2, wherein the additive manufacturing is 3-D printing.

4. The method of any one of claims 1 to 3, wherein the step of seeding a plurality of viable cells into the scaffold includes seeding osteoblasts into the scaffold.
5. The method of any one of claims 1 to 4, wherein the step of seeding a plurality of viable cells into the scaffold includes seeding pluripotent cells into the scaffold.
6. The method of any one of claims 1 to 5, wherein:
growing at least one layer of cartilage on top of the grown bone includes forming a first inner layer of cartilage on the scaffold.
7. The method of claim 6, further comprising:
forming a second layer of cartilage on the first layer of cartilage.
8. The method of any one of claims 1 to 7, wherein the step of incubating the scaffold includes incubating the scaffold in a nutrient rich medium.
9. The method of any one of claims 1 to 8, wherein the step of robotically resecting native bone of the patient includes forming a first interlocking shape in the native bone and the step of robotically machining the alloprosthetic composite implant includes forming a second interlocking shape in the alloprosthetic composite having a complementary shape to the first interlocking shape.

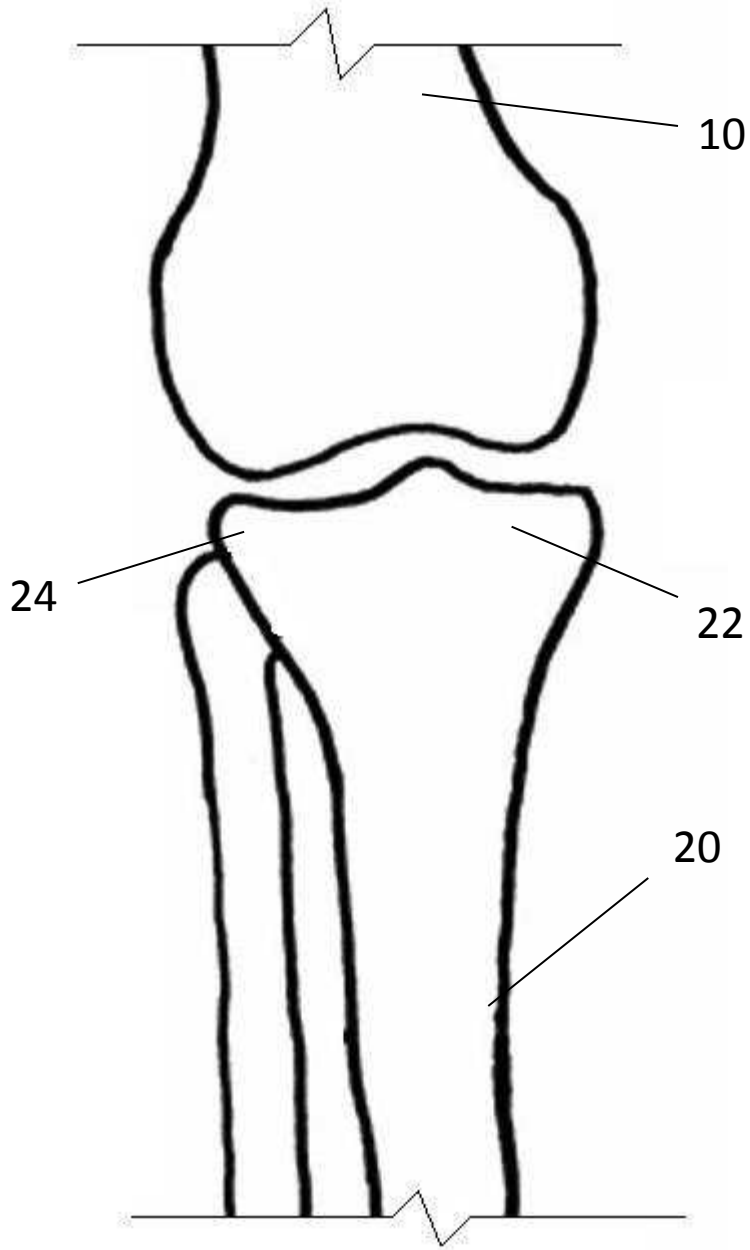

FIG. 1

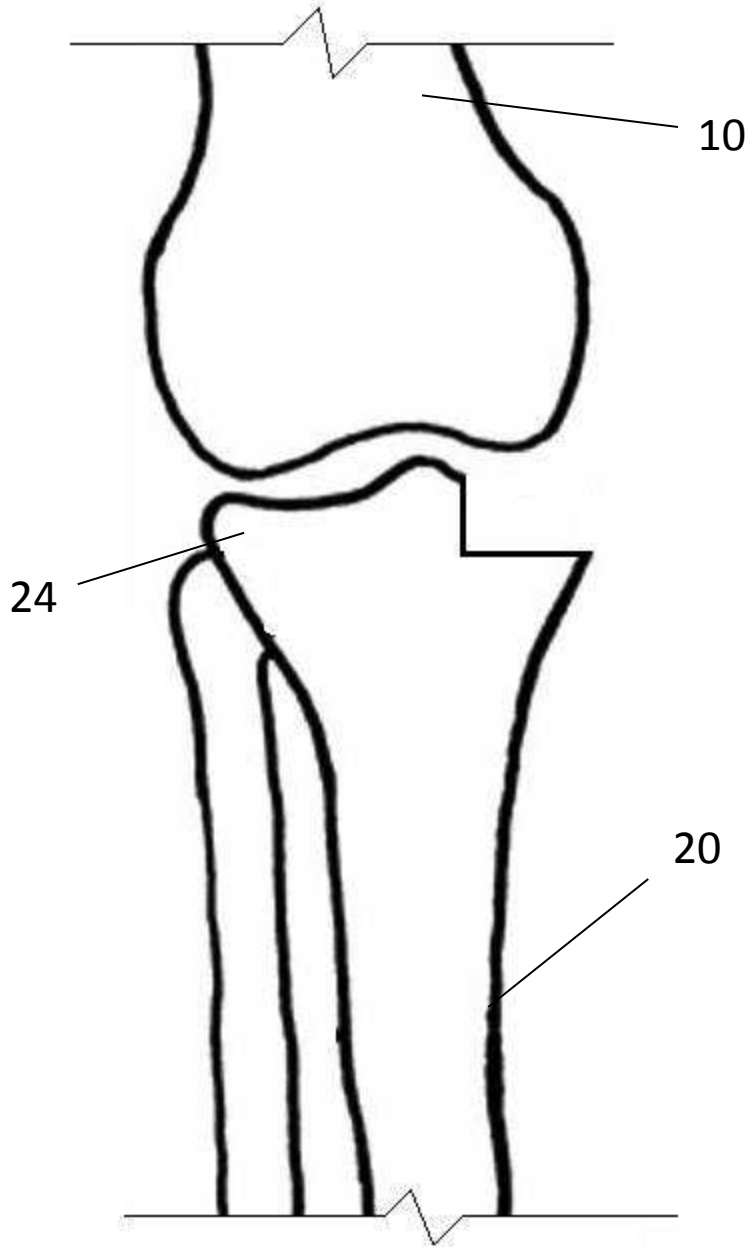

FIG. 2

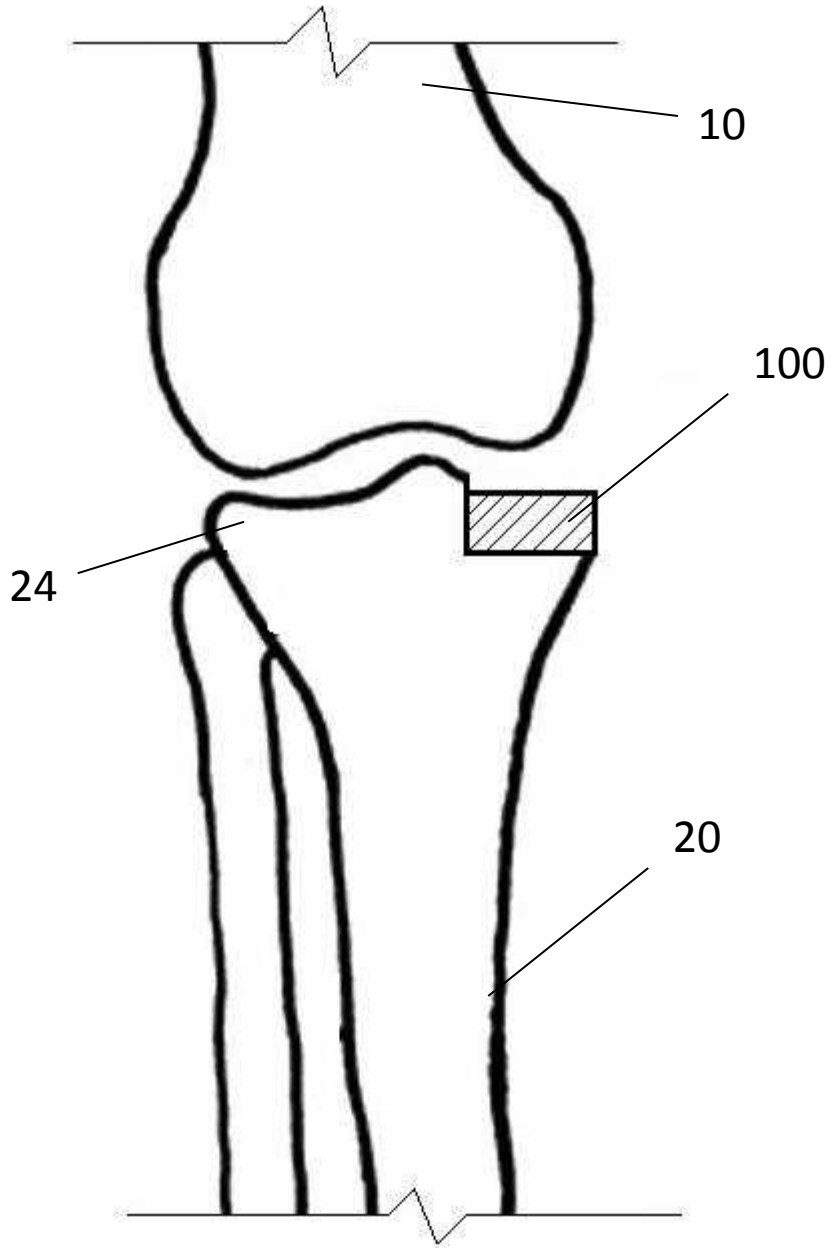

FIG. 3

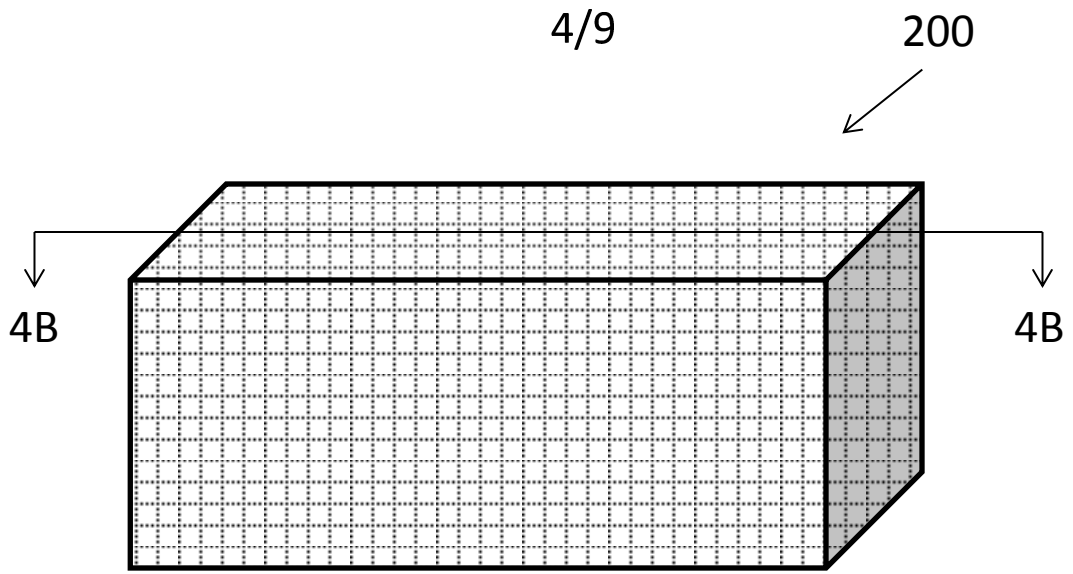

FIG. 4A

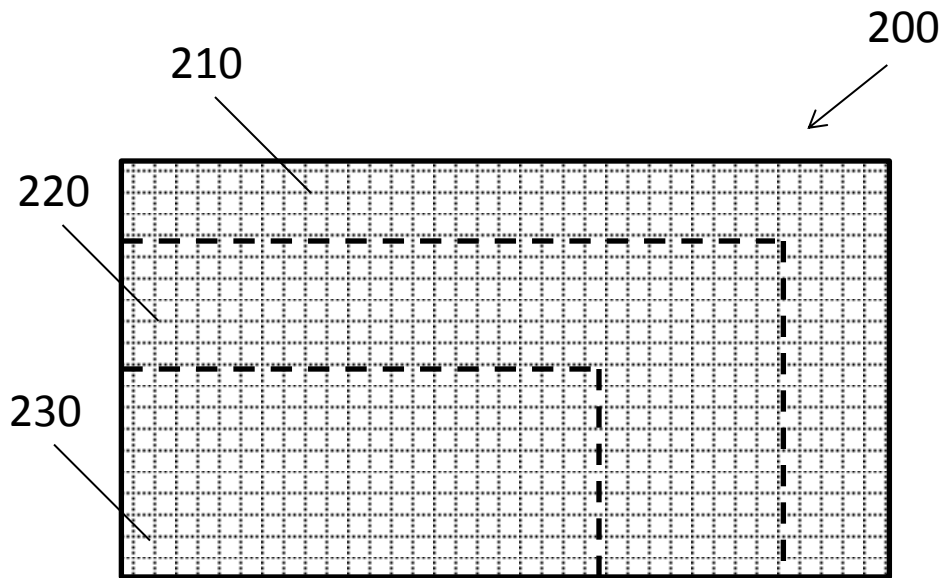

FIG. 4B

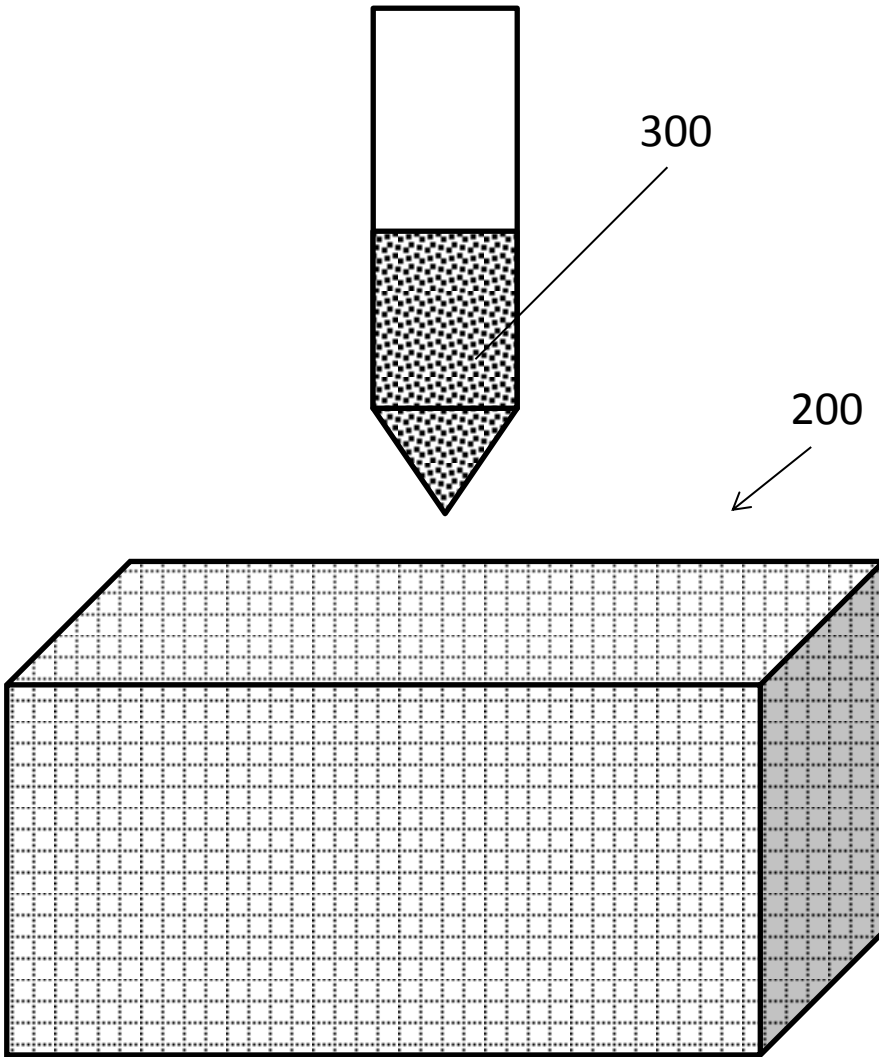

FIG. 5

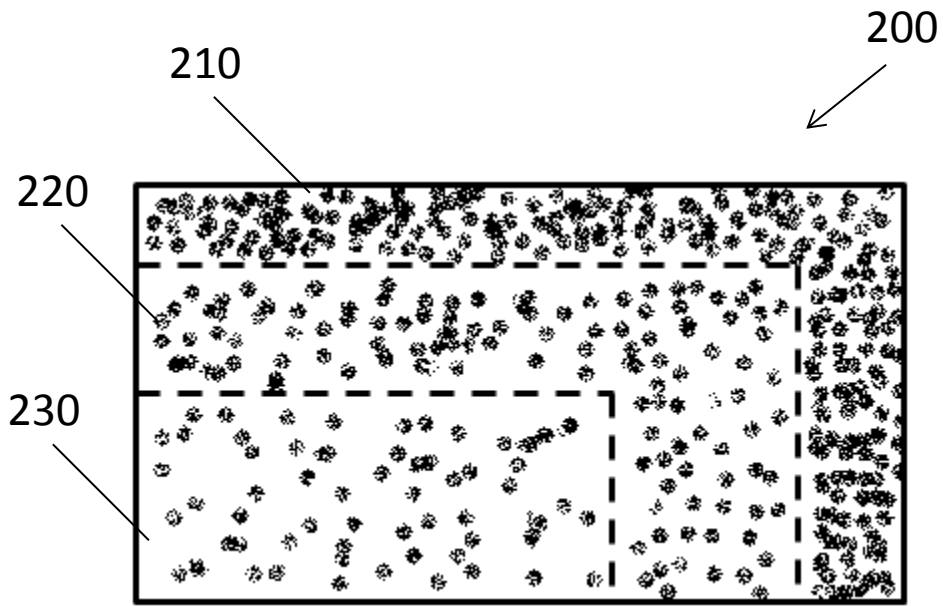

FIG. 6

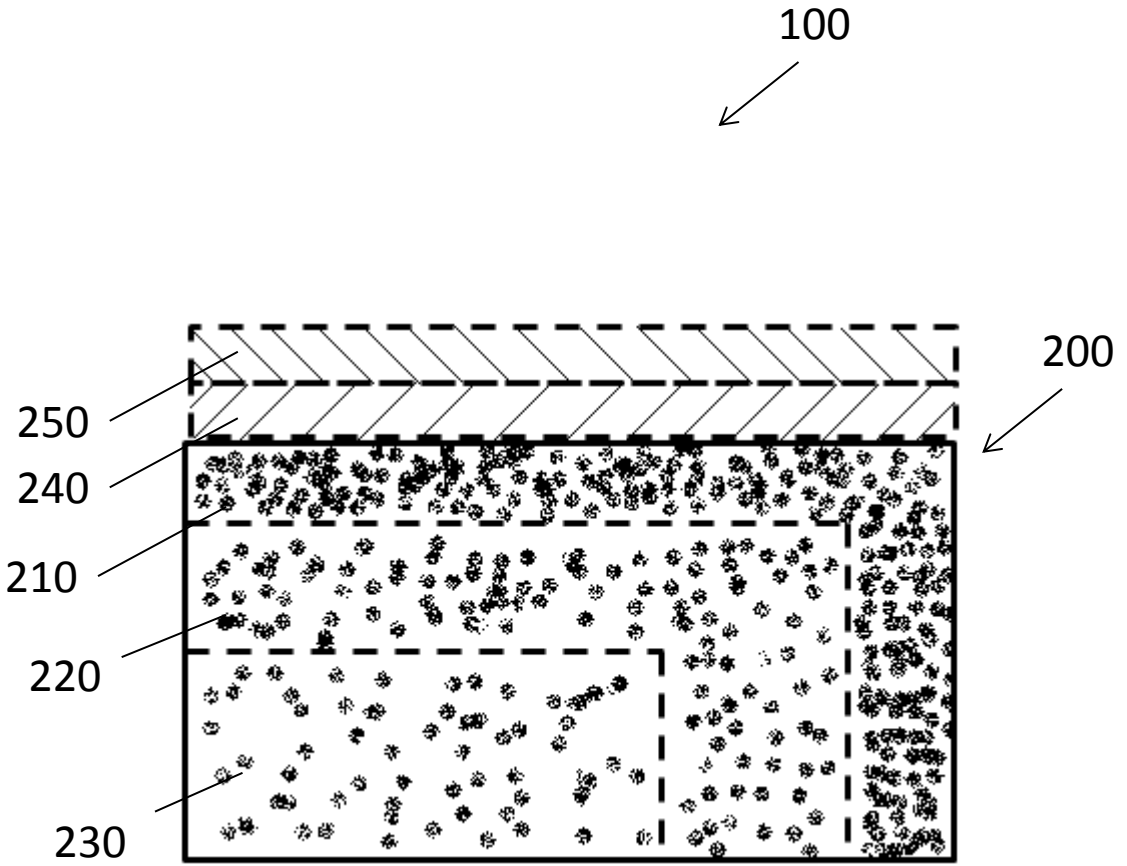

FIG. 7

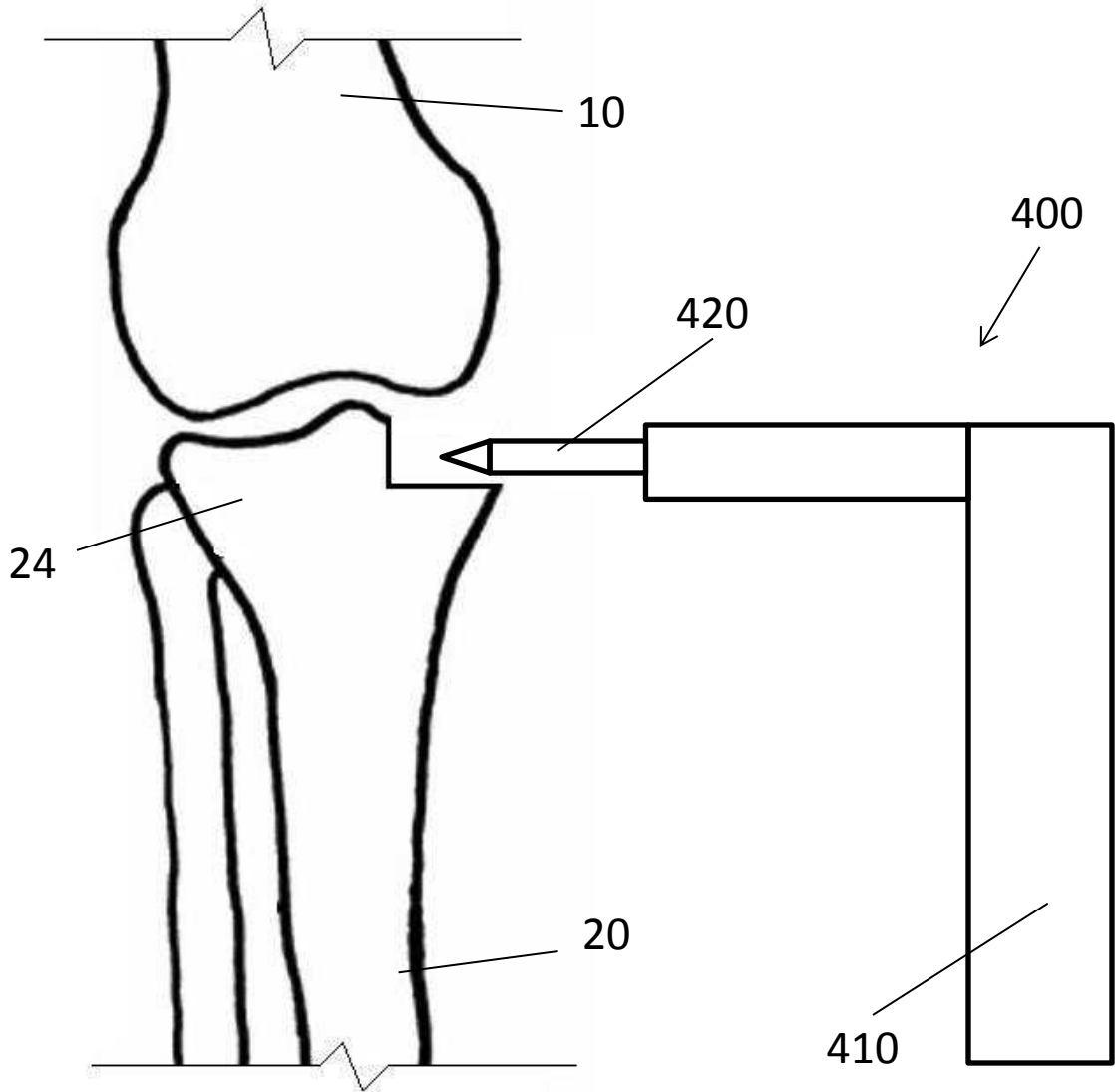

FIG. 8A

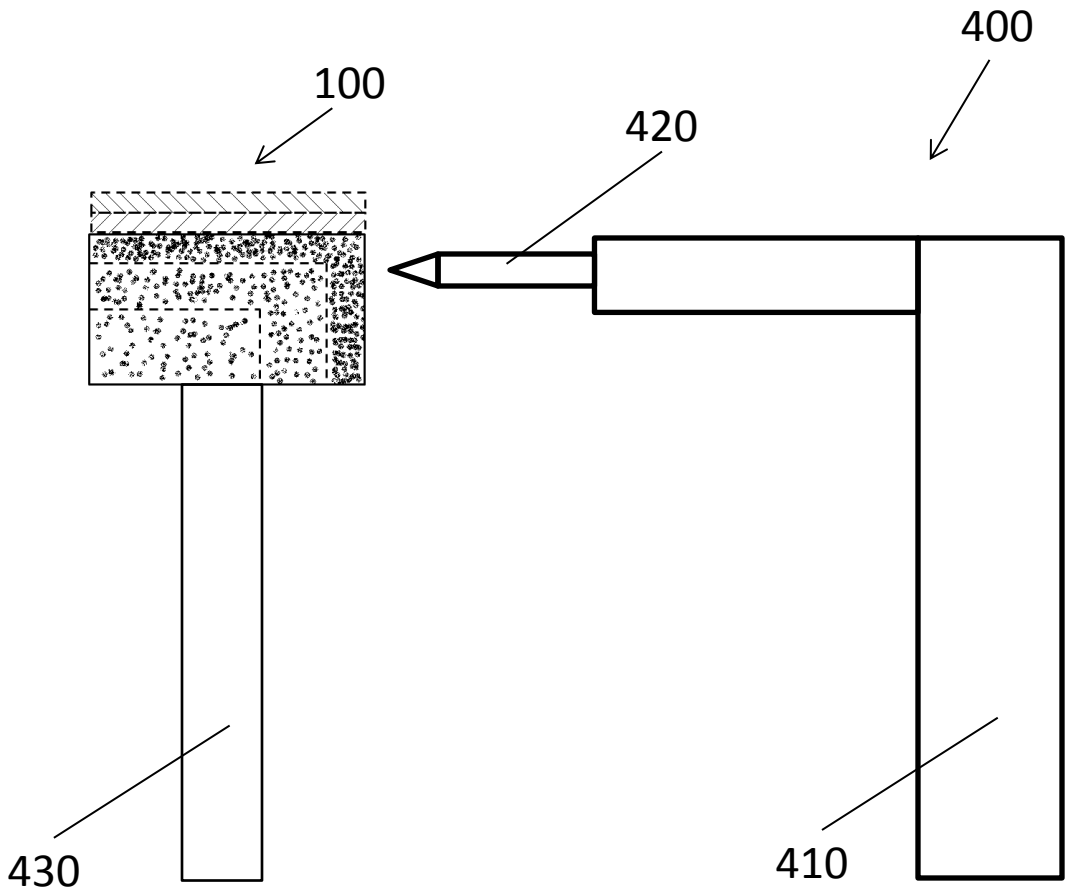

FIG. 8B