

(19)



(11)

EP 3 460 345 B1

(12)

EUROPEAN PATENT SPECIFICATION

(45) Date of publication and mention of the grant of the patent:
25.01.2023 Bulletin 2023/04

(51) International Patent Classification (IPC):
F24F 11/30 ^(2018.01) **F24F 11/52** ^(2018.01)
F24F 11/58 ^(2018.01) **F24F 11/89** ^(2018.01)

(21) Application number: **16902303.3**

(52) Cooperative Patent Classification (CPC):
F24F 11/52; F24F 11/58

(22) Date of filing: **16.05.2016**

(86) International application number:
PCT/JP2016/064453

(87) International publication number:
WO 2017/199283 (23.11.2017 Gazette 2017/47)

(54) **AIR CONDITIONING MANAGEMENT DEVICE AND PROGRAM**

KLIMAAANLAGENREGELUNGSVORRICHTUNG UND PROGRAMM

DISPOSITIF ET PROGRAMME DE GESTION DE CLIMATISATION

(84) Designated Contracting States:
AL AT BE BG CH CY CZ DE DK EE ES FI FR GB GR HR HU IE IS IT LI LT LU LV MC MK MT NL NO PL PT RO RS SE SI SK SM TR

(72) Inventor: **KOMIYA, Noriyuki**
Tokyo 100-8310 (JP)

(43) Date of publication of application:
27.03.2019 Bulletin 2019/13

(74) Representative: **Studio Torta S.p.A.**
Via Viotti, 9
10121 Torino (IT)

(73) Proprietor: **Mitsubishi Electric Corporation**
Chiyoda-ku
Tokyo 100-8310 (JP)

(56) References cited:
EP-A1- 2 866 149 **EP-A1- 2 913 776**
JP-A- 2011 038 682 **JP-A- 2015 017 768**

EP 3 460 345 B1

Note: Within nine months of the publication of the mention of the grant of the European patent in the European Patent Bulletin, any person may give notice to the European Patent Office of opposition to that patent, in accordance with the Implementing Regulations. Notice of opposition shall not be deemed to have been filed until the opposition fee has been paid. (Art. 99(1) European Patent Convention).

Description

Technical Field

[0001] The present invention relates to an air-conditioning management device and a program.

Background Art

[0002] A building management system for integrated management of devices installed in a building is widely known. Techniques are also known that monitor and control operating states of devices such as air conditioners by accessing the building management system via a local area network (LAN) through a terminal device with a general web browser installed therein. One of such techniques is disclosed in Patent Literature 1.

[0003] Patent Literature 1 discloses a technique in which an administration management device is provided between an internal bus of the building management system and the LAN. This administration management device collects, in response to a request from a terminal device connected to the LAN, data of operating states of air conditioners and the like included in the building management system, and edits the collected data to obtain information to be displayed on a screen in hypertext format. The administration management device then transmits the information to the terminal device that is the requestor.

[0004] Patent Literature 2 discloses a device and a program according to the preambles of claims 1 and 4, respectively. Citation List

Patent Literature

[0005]

Patent Literature 1: Unexamined Japanese Patent Application Kokai Publication No. H10-207527

Patent Literature 2: EP 2 866 149

Patent Literature 3: EP 2 913 776

Summary of Invention

Technical Problem

[0006] The building management system of Patent Literature 1 includes a man-machine device. The man-machine device displays the operating states of the air conditioners and the like to an operator residing in a central monitoring room, and receives from the operator an input for controlling operations of the air conditioners and the like. This man-machine device, however, does not adopt display of a screen in hypertext format, thus preventing commonality of design concept of screen display capabilities between the man-machine device and the terminal device. This poses difficulties in reduction in costs including development and maintenance costs.

[0007] The present invention is made for solving the above-mentioned difficulties, and thus an objective of the present invention is to provide an air-conditioning management device and a program for reduction of development cost and the like for screen display capabilities. It is a further objective of the present invention to improve visibility and operability of the management screen.

Solution to Problem

[0008] To achieve the above objectives, an air-conditioning management device according to the present invention is as defined in claim 1. This device includes, in particular, display means, terminal communication means, storage means, web server means, and management screen generation means. The display means displays a management screen for management of operating states of an air conditioner. The terminal communication means communicates with a terminal device. The storage means stores web content data and air-conditioner data relating to the air conditioner. The web server means transmits, in response to a request from the terminal device, the web content data via the terminal communication means to the terminal device. The management screen generation means generates the management screen by synthesizing the air-conditioner data with the screen data that is based on the web content data, and outputs the generated management screen to the display means. The management screen generated by the management screen generation means has the screen layout of the general web browser installed in the terminal device but excludes a particular display field comprised in the screen layout of the web browser installed in the terminal device.

Advantageous Effects of Invention

[0009] According to the present invention, the air-conditioning management device displays management screen by synthesis of air-conditioner data with screen data that is based on web content data provided by the terminal device, thereby reducing development cost for screen display capabilities. In addition, the management screen generated by the management screen generation means has the screen layout of the general web browser installed in the terminal device but excludes a particular display field comprised in the screen layout of the web browser installed in the terminal device. This provides visibility and operability that compares favorably with the conventional management screen.

Brief Description of Drawings

[0010]

FIG. 1 is a diagram illustrating an overall configuration of an air-conditioning management system according to an embodiment of the present invention;

FIG. 2 is a block diagram illustrating a configuration of the air-conditioning management device;
 FIG. 3 is a block diagram illustrating a configuration of a monitoring terminal;
 FIG. 4 is a diagram illustrating an example of a management screen displayed on the monitoring terminal;
 FIG. 5 is a flow chart illustrating steps of a management screen displaying process executed by the monitoring terminal;
 FIG. 6 is a diagram illustrating an example of a management screen displayed on the air-conditioning management device; and
 FIG. 7 is a flow chart illustrating steps of an air-conditioning management process.

Description of Embodiments

[0011] Embodiments of the present invention are described in detail below with reference to the drawings.

[0012] FIG. 1 is a diagram illustrating an overall configuration of an air-conditioning management system 1 according to an embodiment of the present invention. The air-conditioning management system 1 is, for example, a system for managing air conditioning of buildings such as office buildings, and as illustrated in FIG. 1, includes an air-conditioning management device 2, air conditioners 3, monitoring terminals 4, and a remote controller 5.

[0013] The air-conditioning management device 2, the air conditioners 3, and the remote controller 5 are communicatively connected to one another through a communication line 6. The air-conditioning management device 2 and the monitoring terminals 4 are communicatively connected to one another through a communication line 7.

[0014] The air conditioners 3 are installed at different positions in a predetermined room space, and are monitored and controlled under control of the air-conditioning management device 2. The air conditioners 3, upon receiving control data from the air-conditioning management device 2, operate based on the control data. Specifically, the air conditioners 3, in accordance with contents of the received control data, start and stop an operation, switch operation modes including cooling mode, heating mode, dehumidification mode, and ventilation mode, and change setting temperatures, airflow rates, and the like. The air conditioners 3 are also collectively referred to as a group of air conditioners 8.

[0015] The remote controller 5 is disposed near an entrance and exit of the room space in which the group of air conditioners 8 is installed. The remote controller 5 receives an input operation from a user, and transmits, to the group of air conditioners 8 or one or more air conditioners 3 specified by the user, control data that is based on the received input operation. The air conditioners 3 receive the control data transmitted by the remote controller 5, and then operate based on the received control

data. In this case, the air conditioners 3 transmit, to the air-conditioning management device 2, data (operating state data) relating to their own operating states that are changed based on the control data transmitted by the remote controller 5.

[0016] The air-conditioning management device 2 is disposed at an area for authorized personnel only, such as a control room in the building, and performs an integrated management (monitoring and control) of the group of air conditioners 8. The air-conditioning management device 2 includes, as illustrated in FIG. 2, a display 20, an operation receiver 21, an air-conditioner communicator 22, a terminal communicator 23, a data storage 24, and a controller 25.

[0017] The display 20 includes a display device. Examples of the display device include a cathode-ray tube (CRT) display, a liquid crystal display, an organic electroluminescent (EL) display, and a plasma display. The display 20 displays, under control of the controller 25, a management screen for managing the operating states of the group of air conditioners 8. Examples of the management screen include a monitoring screen for monitoring the operating states of the group of air conditioners 8 and an operation screen for controlling the group of air conditioners 8.

[0018] Examples of the operation receiver 21 include a keyboard, a mouse, a keypad, a touchpad, and a touch panel. The operation receiver 21 receives an operation performed by an administrator or the like, and sends to the controller 25 a signal relating to the received operation. When the operation receiver 21 is a touch panel, the operation receiver 21 is disposed on the display 20.

[0019] The air-conditioner communicator 22 serves as an interface to the communication line 6 that is a dedicated communication line. The air-conditioning management device 2 receives data from and transmits data to the air conditioners 3 via the air-conditioner communicator 22. The communication line 6 is not necessarily limited to a dedicated communication line. Instead of the dedicated communication line, for example, a general-purpose communication line may be used that is configured using a LAN, RS-485 interface, and the like.

[0020] The terminal communicator 23 (terminal communication means) serves as an interface to the communication line 7. The air-conditioning management device 2 receives data from and transmits data to the monitoring terminals 4 via the terminal communicator 23. The communication line 7 is a communication path, for example a wired or wireless LAN, which can achieve general-purpose communication. This embodiment uses, as a communication protocol between the air-conditioning management device 2 and the monitoring terminal 4, hypertext transfer protocol (HTTP) that is generally used for web browsers. The communication protocol is, however, not limited to the HTTP, and another protocol, such as WebSocket, can be used.

[0021] The data storage 24 (storage means) includes readable and writable nonvolatile semiconductor mem-

ory such as flash memory, and/or a hard disk drive. The data storage 24 stores data necessary for monitoring and controlling the group of air conditioners 8. Specifically, the data storage 24 stores air-conditioner data 240 and web content data 241.

[0022] The air-conditioner data 240 includes connection information 2400 and operating state management data 2401. The connection information 2400 is information necessary for communication with each air conditioner 3, such as information of each air conditioner 3 regarding an address, an identification number, an operation group number, and device type identification information. The operating state management data 2401 is data for management of the current operating state of each air conditioner 3. Examples of the current operating state include an operating/stopping state, operation modes such as a cooling/heating/ventilation mode, a setting temperature, an indoor temperature, and an indoor humidity. The operating state management data 2401 is updated as necessary upon reception and transmission of data between the air-conditioning management device 2 and each air conditioner 3.

[0023] The web content data 241 defines web contents that are to be displayed on the web browser of the monitoring terminal 4. The web content data 241 includes a screen layout file 2410 and a program 2411.

[0024] The screen layout file 2410 is a group of files created in description language such as a hypertext markup language (HTML). The monitoring terminal 4 can display the management screen, such as the monitoring screen and the operation screen, on a web browser in accordance with the screen layout file 2410 obtained from the air-conditioning management device 2.

[0025] The program 2411 is a program to be downloaded and executed by the monitoring terminal 4. Execution of the program 2411 establishes various types of communication of the monitoring terminal 4 with the air-conditioning management device 2. The monitoring terminal 4 can thereby obtain data relating to the air conditioners 3. The program 2411 is described in, for example, JavaScript (R), Java (R) applets, Flash (R), or the like.

[0026] In addition to the above, the data storage 24 stores one or more programs for management of the operating states of the air conditioners 3 though the programs are not illustrated.

[0027] The controller 25 includes a central processing unit (CPU), a read only memory (ROM), and a random access memory (RAM), all non-illustrated, and performs an integrated control of the air-conditioning management device 2. Detailed features of the controller 25 are described below.

[0028] Again with reference to FIG. 1, the monitoring terminal 4 (terminal device) is a personal computer with general-purpose web browser capabilities. The monitoring terminal 4 receives the web content data 241 via the communication line 7 from the air-conditioning management device 2, and displays the management screen, such as the monitoring screen and the operation screen,

in accordance with the web content data 241. Displaying of the management screen on the monitoring terminal 4 can be achieved, for example such that the air-conditioning management device 2 and the monitoring terminal 4 of each user are connected to the general-purpose communication line 7 that forms a LAN (or a dedicated LAN) and then a uniform resource locator (URL) of the web content data 241 stored in the air-conditioning management device 2 is entered in the web browser of the monitoring terminal 4. The configuration of the monitoring terminal 4 is described in detail below.

[0029] As illustrated in FIG. 3, the monitoring terminal 4 includes a display 40, an operation receiver 41, a communicator 42, a data storage 43, and a controller 44.

[0030] The display 40 includes a display device and displays various types of information. Examples of the display device include a CRT display, a liquid crystal display, an organic EL display, and a plasma display. For example, the display 40 displays, under control of the controller 44, the management screen of the group of air conditioners 8 on a web browser based on the web content data 241 obtained from the air-conditioning management device 2.

[0031] Examples of the operation receiver 41 include a keyboard, a mouse, a keypad, a touchpad, and a touch panel. Upon a user's request through the operation receiver 41, a signal associated with the request is sent to the controller 44. This enables the user to, for example, switch the management screens or cause the group of air conditioners 8 or a specific air conditioner 3 to operate as requested. When the operation receiver 41 is a touch panel, the operation receiver 41 is disposed on the display 40.

[0032] The communicator 42 serves as an interface to the communication line 7. The monitoring terminal 4 receives data from and transmits data to the air-conditioning management device 2 via the communicator 42.

[0033] The data storage 43 includes, for example, readable and writable nonvolatile semiconductor memory such as flash memory, and/or a hard disk drive. The data storage 43 stores various types of data necessary for the controller 44 to perform display processing of the management screen.

[0034] The controller 44 includes non-illustrated components such as a CPU, a ROM, and a RAM, and performs integrated control of the monitoring terminal 4. Characteristically, the controller 44 obtains the web content data 241 from the air-conditioning management device 2, and performs processing for displaying the management screen on the display 40 based on the obtained web content data 241. The controller 44 functionally includes a screen layout file analyzer 440 and a program executor 441.

[0035] The screen layout file analyzer 440 retrieves the screen layout file 2410 included in the web content data 241 obtained from the air-conditioning management device 2, and generates screen data that constitutes a base screen of the management screen.

[0036] The program executor 441 executes the program 2411 included in the web content data 241. The program executor 441 thereby communicates with the air-conditioning management device 2 via the communicator 42 to obtain necessary data, and then generates the management screen and displays the generated management screen on the display 40. The program executor 441 includes a data communication manager 4410 and a management screen generator 4411.

[0037] The data communication manager 4410 executes the program 2411 periodically or upon receiving an instruction from a user, and thereby communicates with the air-conditioning management device 2 and obtains data, such as the air-conditioner data 240.

[0038] The management screen generator 4411 generates the management screen that is obtained by synthesis of the screen data generated by the screen layout file analyzer 440 and the data obtained by the data communication manager 4410, and displays the generated management screen on the display 40. The management screen generator 4411 generates the management screen, for example by embedding of various types of information indicated by the data obtained by the data communication manager 4410 into the screen data generated by the screen layout file analyzer 440. FIG. 4 illustrates an example of the management screen displayed on the monitoring terminal 4.

[0039] FIG. 5 is a flow chart illustrating steps of the management screen displaying process executed by the monitoring terminal 4. The management screen displaying process starts with a user's entering the URL of the web content data 241 stored in the air-conditioning management device 2 through the web browser of the monitoring terminal 4.

[0040] The controller 44 obtains the web content data 241 from the air-conditioning management device 2 (step S101). The controller 44 then analyzes the screen layout file 2410 included in the obtained web content data 241, and generates the screen data that constitutes a base screen of the management screen (step S102).

[0041] The controller 44 executes the program 2411 included in the obtained web content data 241 (step S103). The controller 44 then communicates with the air-conditioning management device 2 in accordance with the content of the program 2411, and obtains data (e.g., operating state management data 2401) relating to the air conditioner 3 (step S104).

[0042] Subsequently, the controller 44 generates the management screen that is obtained by embedding, in the screen data generated in step S102, various types of information indicated by the data obtained in step S104, and displays the generated management screen on the display 40 (step S105). This is the end of the management screen displaying process.

[0043] Again with reference to FIG. 2, the controller 25 of the air-conditioning management device 2 functionally includes an air-conditioner manager 250, a web server 251, and a management screen generator 252. The func-

tions of these functional components are achieved by the CPU or the like executing one or more non-illustrated programs that are stored in the data storage 24 and used for management of the operating state of the air conditioner 3.

[0044] The air-conditioner manager 250 performs processing similar to a typical air-conditioning management device of this type. For example, the air-conditioning management device 250 performs processing for control of the running operation of the air conditioner 3 in accordance with an operation instruction received through the management screen from a user. The air-conditioner manager 250 updates the content of the operating state management data 2401 of the air-conditioner data 240 upon receiving through the air-conditioner communicator 22 the above-described operating state data transmitted by the air conditioner 3.

[0045] The web server 251 transmits, in response to a request from the monitoring terminal 4, data including the web content data 241 and the operating state management data 2401 to the monitoring terminal 4 that is the requestor.

[0046] The management screen generator 252 generates the management screen for managing the operating state of the group of air conditioners 8, and displays the generated management screen on the display 20. As described above, examples of the management screen include the monitoring screen for monitoring the operating states of the group of air conditioners 8 and the operation screen for controlling the group of air conditioners 8 or a particular air conditioner 3. The management screen generator 252 switches or updates the management screen in accordance with the user operation or updates the management screen in response to the update of the content of the operating state management data 2401.

[0047] The management screen generator 252 generates and displays the management screen based on the web content data 241 and the air-conditioner data 240 stored in the data storage 24. Specifically, the management screen generator 252 retrieves the screen layout file 2410 included in the web content data 241 and generates screen data that constitutes a base screen of the management screen. The management screen generator 252 then generates a management screen by synthesizing the generated screen data and the data obtained from the air-conditioner data 240, that is, by embedding in the generated screen data the various types of information that the obtained data indicates or by other synthesis methods. The management screen generator 252 thus includes a function similar to a general web browser installed in the monitoring terminal 4. The functions of the management screen generator 252 include the following characteristics.

(1) Removal of screen frame or display fields in the screen layout of a general web browser

[0048] As illustrated in FIG. 4, the browser displays

various fields including a body field for displaying a web page (herein, management screen), a screen frame, a field for displaying a title, a field for displaying tools including a "back" button (toolbar field), a field for input of a URL (URL field), and a state field for displaying states including a read state. The management screen generator 252 hides some fields of the above-described fields except for the body field. Here, the hidden fields include at least the URL field.

(2) Change of resolution

[0049] The management screen generator 252 generates the management screen by changing a resolution of the image data defined by the screen layout file 2410 included in the web content data 241 to an appropriate value based on the specifications of the display 20. Data relating to the specifications of the display 20 (monitor specifications data) is pre-stored in the data storage 24. The monitor specifications data can be changed as appropriate by a user operation through the operation receiver 21.

[0050] FIG. 6 illustrates an example of the management screen generated by the management screen generator 252 as described above and displayed on the display 20.

[0051] FIG. 7 is a flow chart illustrating steps of an air-conditioning management process executed by the air-conditioning management device 2. The air-conditioning management process starts when the air-conditioning management device 2 is powered on.

[0052] Firstly, the management screen generator 252 generates a top screen (main screen) of the management screen based on the web content data 241 and the air-conditioner data 240 stored in the data storage 24, and displays the generated top screen on the display 20 (step S201).

[0053] Upon a user's operation through the displayed management screen (Yes in step S202), the management screen generator 252 switches or updates the management screen (step S203). Without the user operation (No in step S202), the processing of the air-conditioning management device 2 goes to step S206.

[0054] When the user operation is involved in an instruction for control of the air conditioner 3 (Yes in step S204), the air-conditioner manager 250 generates control data in accordance with the control instruction, and transmits the generated control data to the group of air conditioners 8 or a specified air conditioner 3 (step S205). When the user operation is not involved in the instruction for control of the air conditioner 3 (No in step S204), the processing of the air-conditioning management device 2 goes to step S206.

[0055] In step S206, a determination is made as to whether the content of the operating state management data 2401 stored in the data storage 24 is updated. When the content of the operating state management data 2401 is updated (Yes in step S206), the management screen

generator 252 updates the management screen based on the updated content (step S207). When the content of the operating state management data 2401 is not updated (No in step S206), the processing of the air-conditioning management device 2 goes to step S208.

[0056] In step S208, a determination is made as to whether there is a request of data from the monitoring terminal 4. When there is the request (Yes in step S208), the web server 251 transmits the web content data 241 or the air-conditioner data 240 to the monitoring terminal 4 that is the requestor (step S209). After step S209 or when there is no request from the monitoring terminal 4 (No in step S208), the processing of the air-conditioning management device 2 returns to step S202.

[0057] As described above, the air-conditioning management device 2 of the air-conditioning management system 1 according to the embodiment of the present invention includes the management screen generator 252 having characteristics similar to a web browser. The management screen generator 252 generates the management screen based on the web content data 241 that defines the web content displayed on the web browser of the monitoring terminal 4, and displays the generated management screen on the display 20. This enables the air-conditioning management device 2 and monitoring terminal 4 to share common design concepts on the display capabilities of the management screen, thereby reducing man-hours of development and maintenance (e.g., changes and modifications) and thus reducing costs in development and maintenance.

[0058] In addition, the air-conditioning management device 2 is not required to hold dedicated screen data separately since the management screen generator 252 generates the management screen based on the web content data 241, thereby reducing memory capacity and manufacturing costs.

[0059] The management screen generator 252 generates the management screen excluding the screen frame and a particular display field in the screen layout of the general web browser, such as the URL field, and displays the generated management screen. Due to such a configuration, an administrator or the like does not feel uncomfortable when operating the air-conditioning management device 2. This can thus provide visibility and operability that compares favorably with the conventional management screen.

[0060] The management screen generator 252 generates the management screen by changing the resolution of the image data defined by the screen layout file 2410 included in the web content data 241 to an appropriate value based on the specifications of the display 20. This obviates the necessity of processing including tuning of display so as to be adapted to each of the air-conditioning management device 2 and the monitoring terminal 4, thereby reducing costs in development, manufacturing, and maintenance.

[0061] The present invention is not limited to the above embodiment, and various modifications can be of course

made without departing from the scope of the invention as defined by the claims.

[0062] For example, the management screen generator 252 may, in accordance with a predetermined condition, enlarge operation target elements (e.g., an icon, a scroll button, a scrollbar) included in the management screen or expand a detection area (that is an allowable area) of a touch operation for the operation target elements. This further improves visibility and operability for the administrator or the like.

[0063] According to the invention, the management screen generated by the management screen generation means has the screen layout of the general web browser installed in the terminal device but excludes a particular display field comprised in the screen layout of the web browser installed in the terminal device. The management screen may be configured such that an administrator or the like can perform through the operation receiver 21 an operation to set whether to remove the screen frame and a particular display field, such as the URL field, from the screen layout of the general web browser. In this case, the management screen generator 252 determines based on the settings whether the screen frame and/or a particular display field is removed. However, according to the invention, the management screen generated by the management screen generation necessarily excludes a particular display field comprised in the screen layout of the web browser installed in the terminal device.

[0064] In the above embodiment, the CPU or the like executes one or more programs that are stored in the data storage 24 and used for management of the operating state of the air conditioner 3, thereby achieving the functions of the functional components (see FIG. 2) of the air-conditioning management device 2. All or part of the functions of the functional components of the air-conditioning management device 2 may be achieved by dedicated hardware. Examples of the dedicated hardware include a single circuit, a composite circuit, a programmed processor, an application specific integrated circuit (ASIC), a field-programmable gate array (FPGA), and a combination thereof.

[0065] In the above embodiment, the program to be executed by the air-conditioning management device 2 can be distributed in a form of a computer-readable recording medium storing the program, such as a compact disc read only memory (CD-ROM), a digital versatile disc (DVD), a magneto-optical disk (MO), a USB memory, a memory card, and the like. The program may be installed in a specific or general-purpose computer to enable the computer to serve as the air-conditioning management device 2 according to the above embodiment.

[0066] The above-described program may be stored on a disk device or the like of a server device on a communication network such as the Internet to enable the program to be downloaded to the computer, for example by superimposing the program onto a carrier wave. Moreover, the above-described processing can be achieved

even by execution while the program is transferred through the communication network. Furthermore, the above-described processing can be achieved by executing all or part of the program on the server device, and executing the program while sending and receiving by the computer the information relating to such processing through the communication network.

[0067] Moreover, if the above-described functions are executed by sharing the functions between an operating system (OS) and application programs, or are executed by both the OS and the application programs in cooperation with each other, the non-OS portion alone may be stored and distributed in the above-described recording medium, or alternatively, may be, for example, downloaded to the computer.

Industrial Applicability

[0068] The present invention may be used with advantage in an air-conditioning management system installed in an office building or the like.

Reference Signs List

[0069]

- 1 Air-conditioning management system
- 2 Air-conditioning management device
- 3 Air conditioner
- 4 Monitoring terminal
- 5 Remote controller
- 6, 7 Communication line
- 8 Group of air conditioners
- 20,40 Display
- 21, 41 Operation receiver
- 22 Air-conditioner communicator
- 23 Terminal communicator
- 24, 43 Data storage
- 25, 44 Controller
- 42 Communicator
- 240 Air-conditioner data
- 241 Web content data
- 250 Air-conditioner manager
- 251 Web server
- 252, 4411 Management screen generator
- 440 Screen layout file analyzer
- 441 Program executor
- 2400 Connection information
- 2401 Operating state management data
- 2410 Screen layout file
- 2411 Program
- 4410 Data communication manager

Claims

1. An air-conditioning management device (2), comprising:

display means (20) for displaying a management screen for management of operating states of an air conditioner (3); terminal communication means (23) for communicating with a terminal device (4) having a general web browser installed therein with a screen layout comprising a particular display field; storage means (24) for storing web content data and air-conditioner data relating to the air conditioner (3); web server means (251) for transmitting, in response to a request from the terminal device (4), the web content data via the terminal communication means (23) to the terminal device (4); and management screen generation means (252) for generating the management screen by synthesizing the air-conditioner data with screen data that is based on the web content data, and outputting the generated management screen to the display means (20),

characterised in that

the management screen generated by the management screen generation means (252) has the screen layout of the general web browser installed in the terminal device (4) but excludes said particular display field.

2. The air-conditioning management device (2) according to claim 1, **characterized in that** the management screen generation means (252) generates the management screen by changing a resolution of image data included in the web content data.
3. The air-conditioning management device (2) according to claim 1 or 2, **characterized in that** the management screen generation means (252) generates the management screen by increasing, in accordance with a predetermined condition, a size of specific image data included in the web content data.
4. A program causing a computer including storage means (24) for storing web content data and air-conditioner data relating to an air conditioner (3) to function as:

web server means (251) for transmitting, in response to a request from a terminal device (4), the web content data via communication means (23) to the terminal device (4); the terminal device (4) having a general web browser installed therein with a screen layout comprising a particular display field; and management screen generation means (252) for generating a management screen for management of operating states of the air conditioner (3) by synthesizing the air-conditioner data with screen data that is based on the web content data,

characterised in that

the management screen generated by the management screen generation means (252) has the screen layout of the general web browser installed in the terminal device (4) but excludes said particular display field.

Patentansprüche

1. Klimatisierungssteuervorrichtung (2), die Folgendes umfasst:

Anzeigemittel (20) zum Anzeigen eines Steuerbildschirms zum Steuern von Betriebszuständen einer Klimaanlage (3);

Endgerät-Kommunikationsmittel (23) zur Kommunikation mit einem Endgerät (4), auf dem ein üblicher Web-Browser mit einem Bildschirmlayout installiert ist, das ein bestimmtes Anzeigefeld umfasst;

Speichermittel (24) zum Speichern von Web-Content-Daten und Klimaanlage-daten, die sich auf die Klimaanlage (3) beziehen;

Web-Server-Mittel (251) zum Übertragen der Web-Content-Daten über die Endgerät-Kommunikationsmittel (23) an das Endgerät (4) in Reaktion auf eine Anfrage vom Endgerät (4); und

Steuerbildschirm-Erzeugungsmittel (252) zum Erzeugen des Steuerbildschirms durch Synthetisieren der Klimaanlage-daten mit Bildschirm-daten, die auf den Web-Content-Daten basieren, und Ausgeben des erzeugten Steuerbildschirms an die Anzeigemittel (20),

dadurch gekennzeichnet, dass

der Steuerbildschirm, der durch die Steuerbildschirm-Erzeugungsmittel (252) erzeugt wird, das Bildschirmlayout des üblichen Web-Browsers hat, der auf dem Endgerät (4) installiert ist, jedoch das bestimmte Anzeigefeld ausgeschlossen ist.

2. Klimatisierungssteuervorrichtung (2) nach Anspruch 1, **dadurch gekennzeichnet, dass** die Steuerbildschirm-Erzeugungsmittel (252) den Steuerbildschirm durch Ändern einer Auflösung von Bilddaten, die in den Web-Content-Daten enthalten sind, erzeugen.

3. Klimatisierungssteuervorrichtung (2) nach Anspruch 1 oder 2, **dadurch gekennzeichnet, dass** die Steuerbildschirm-Erzeugungsmittel (252) den Steuerbildschirm durch Erhöhen einer Größe von bestimmten Bilddaten, die in den Web-Content-Daten enthalten sind, in Übereinstimmung mit einer vorgegebenen Bedingung erzeugen.

4. Programm, das veranlasst, dass ein Computer, der Speichermittel (24) zum Speichern von Web-Content-Daten und Klimaanlagedaten, die sich auf eine Klimaanlage (3) beziehen, umfasst, Folgendes bereitstellt:

Web-Server-Mittel (251), um in Reaktion auf eine Anfrage von einem Endgerät (4) die Web-Content-Daten über Kommunikationsmittel (23) an das Endgerät (4) zu übertragen; wobei das Endgerät (4) einen üblichen Web-Browser hat, der darauf installiert ist, wobei ein Bildschirm-layout ein bestimmtes Anzeigefeld umfasst; und Steuerbildschirm-Erzeugungsmittel (252), um einen Steuerbildschirm zum Steuern von Betriebszuständen der Klimaanlage (3) durch Synthetisieren der Klimaanlagedaten mit Bildschirmdaten, die auf den Web-Content-Daten basieren, zu erzeugen,

dadurch gekennzeichnet, dass

der Steuerbildschirm, der durch die Steuerbildschirm-Erzeugungsmittel (252) erzeugt wird, das Bildschirm-layout des üblichen Web-Browsers hat, der auf dem Endgerät (4) installiert ist, jedoch das bestimmte Anzeigefeld ausgeschlossen ist.

Revendications

1. Dispositif de gestion de climatisation (2), comprenant :

un moyen d'affichage (20) pour l'affichage d'un écran de gestion pour la gestion d'états de fonctionnement d'un climatiseur (3) ;

un moyen de terminal de communication (23) pour une communication avec un dispositif terminal (4) ayant un navigateur web général installé dans celui-ci avec une disposition d'écran comprenant un champ d'affichage particulier ;

un moyen de stockage (24) pour le stockage de données de contenu web et de données de climatiseur se rapportant au climatiseur (3) ;

un moyen de serveur web (251) pour l'émission, en réponse à une requête provenant du dispositif terminal (4), des données de contenu web via le moyen de terminal de communication (23) vers le dispositif terminal (4) ; et

un moyen de génération d'écran de gestion (252) pour la génération de l'écran de gestion par la synthèse des données de climatiseur avec des données d'écran qui sont basées sur les données de contenu web, et la sortie de l'écran de gestion généré vers le moyen d'affichage (20),

caractérisé en ce que

l'écran de gestion généré par le moyen de gé-

nération d'écran de gestion (252) possède la disposition d'écran du navigateur web général installé dans le dispositif terminal (4) mais exclut ledit champ d'affichage particulier.

2. Dispositif de gestion de climatisation (2) selon la revendication 1, **caractérisé en ce que** le moyen de génération d'écran de gestion (252) génère l'écran de gestion par le changement d'une résolution de données d'image incluses dans les données de contenu web.

3. Dispositif de gestion de climatisation (2) selon la revendication 1 ou 2, **caractérisé en ce que** le moyen de génération d'écran de gestion (252) génère l'écran de gestion par l'augmentation, conformément à une condition prédéterminée, d'une taille de données d'image spécifiques incluses dans les données de contenu web.

4. Programme amenant un ordinateur incluant un moyen de stockage (24) pour le stockage de données de contenu web et de données de climatiseur se rapportant à un climatiseur (3) à fonctionner comme :

un moyen de serveur web (251) pour l'émission, en réponse à une requête provenant d'un dispositif terminal (4), des données de contenu web via un moyen de communication (23) vers le dispositif terminal (4) ; le dispositif terminal (4) ayant un navigateur web général installé dans celui-ci avec une disposition d'écran comprenant un champ d'affichage particulier ; et un moyen de génération d'écran de gestion (252) pour la génération d'un écran de gestion pour la gestion d'états de fonctionnement du climatiseur (3) par la synthèse des données de climatiseur avec des données d'écran qui sont basées sur les données de contenu web,

caractérisé en ce que

l'écran de gestion généré par le moyen de génération d'écran de gestion (252) possède la disposition d'écran du navigateur web général installé dans le dispositif terminal (4) mais exclut ledit champ d'affichage particulier.

FIG. 1

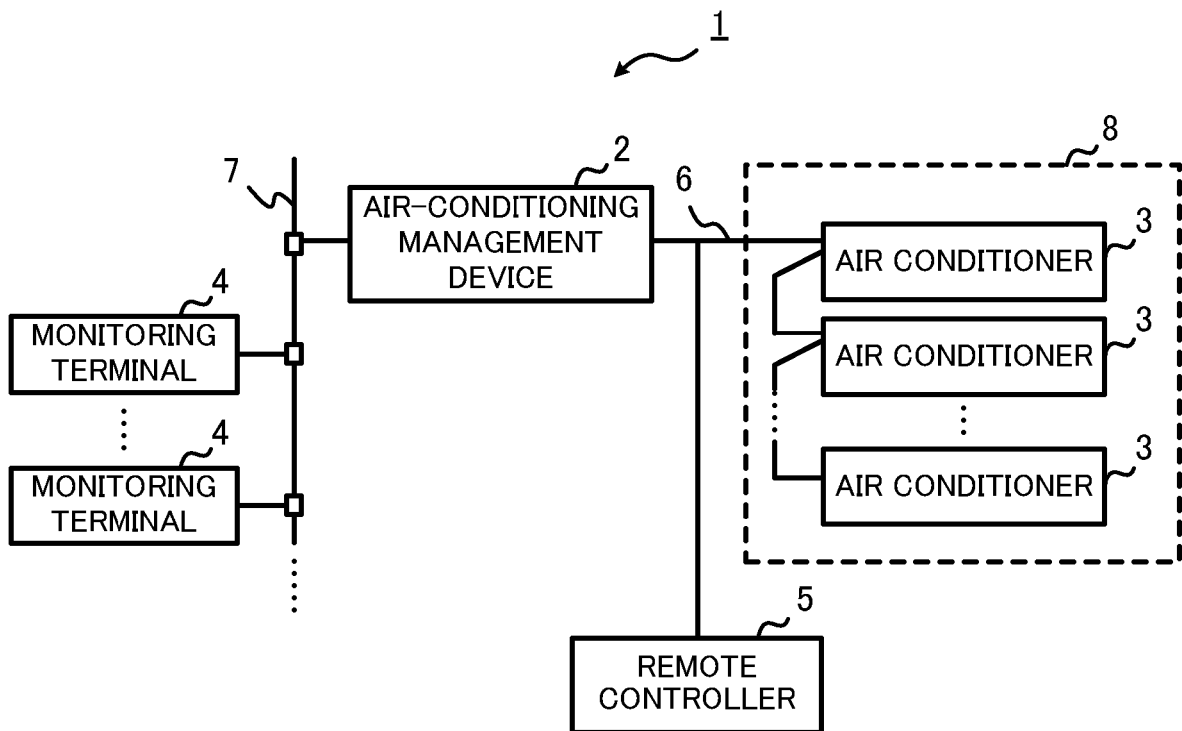

FIG.2

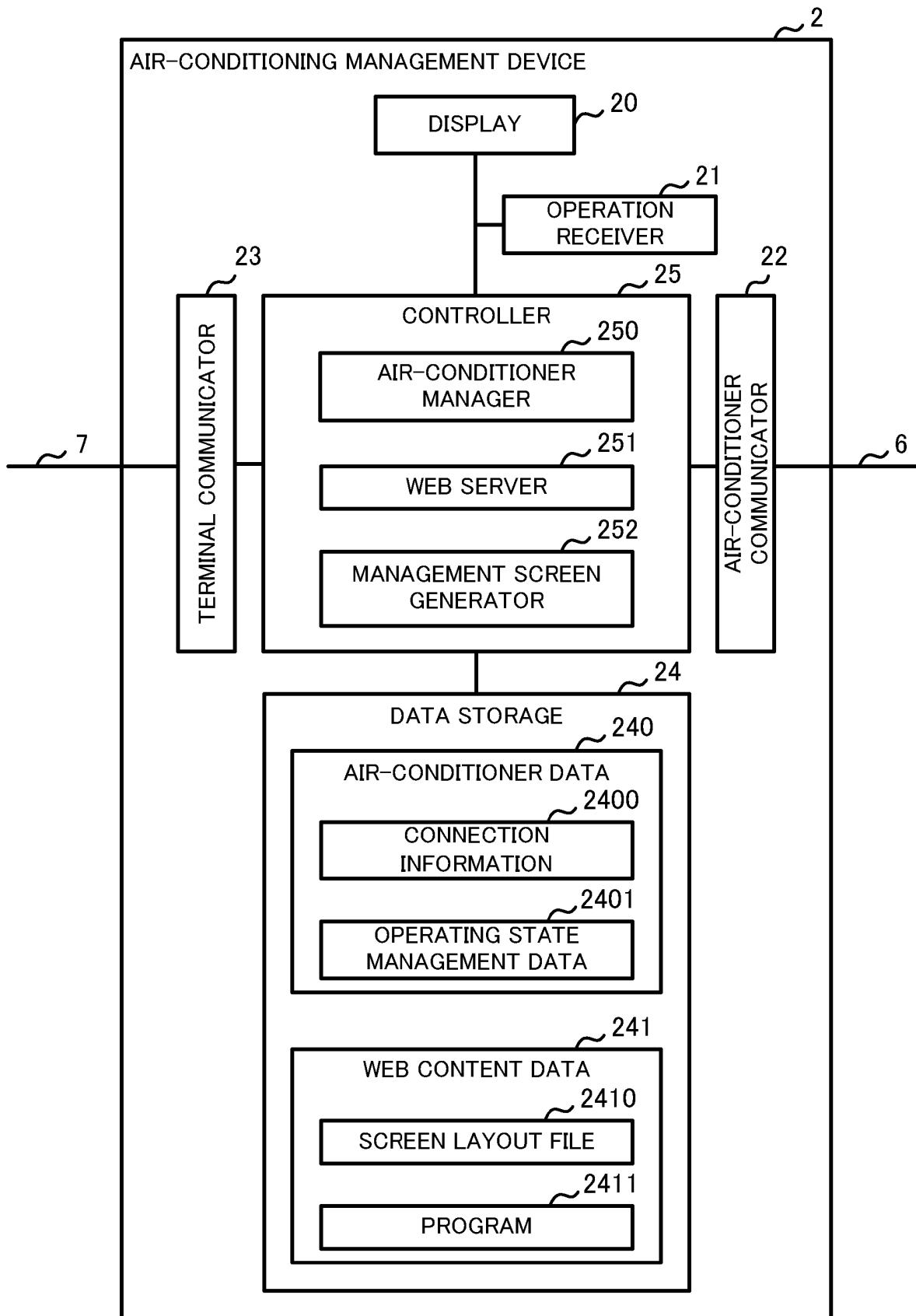

FIG.3

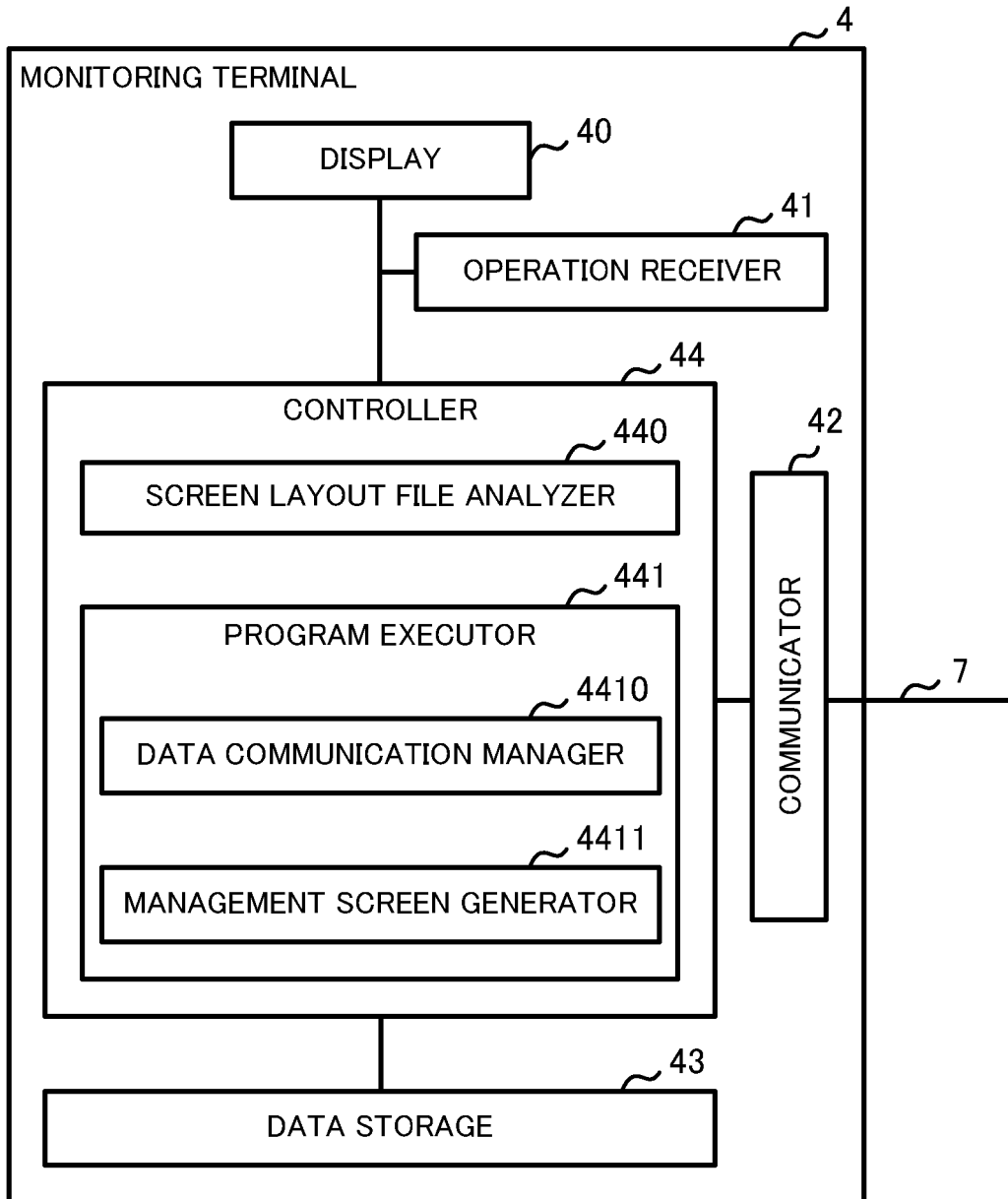

FIG.4

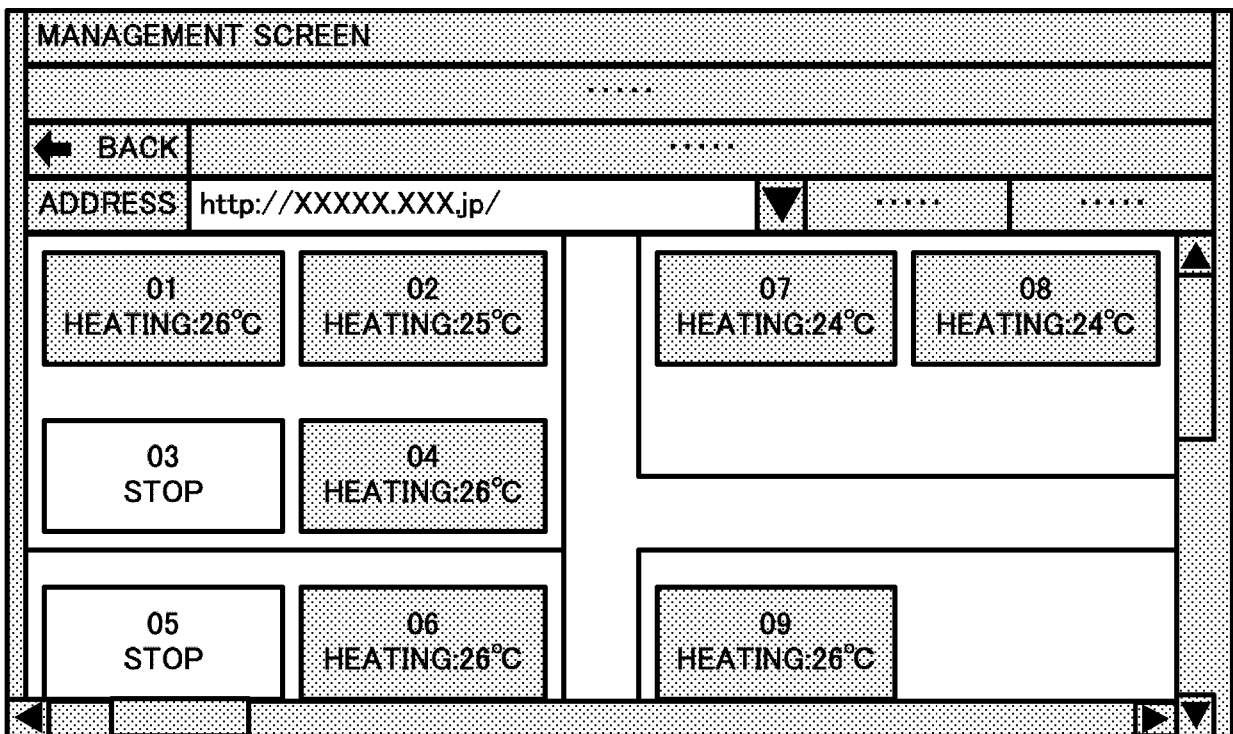

FIG.5

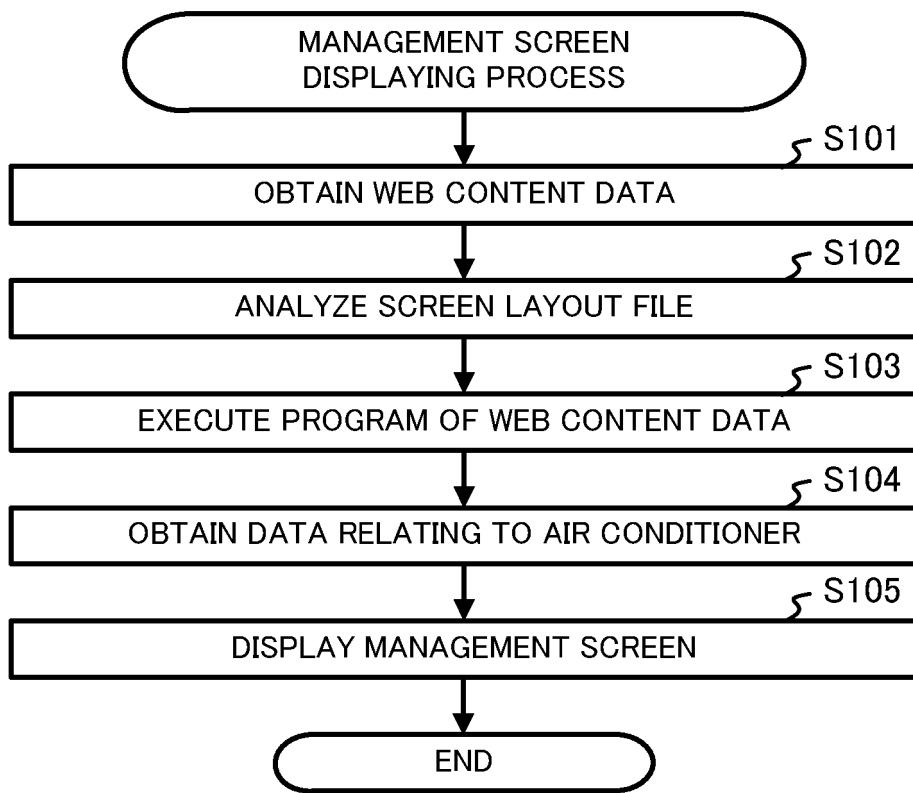

FIG.6

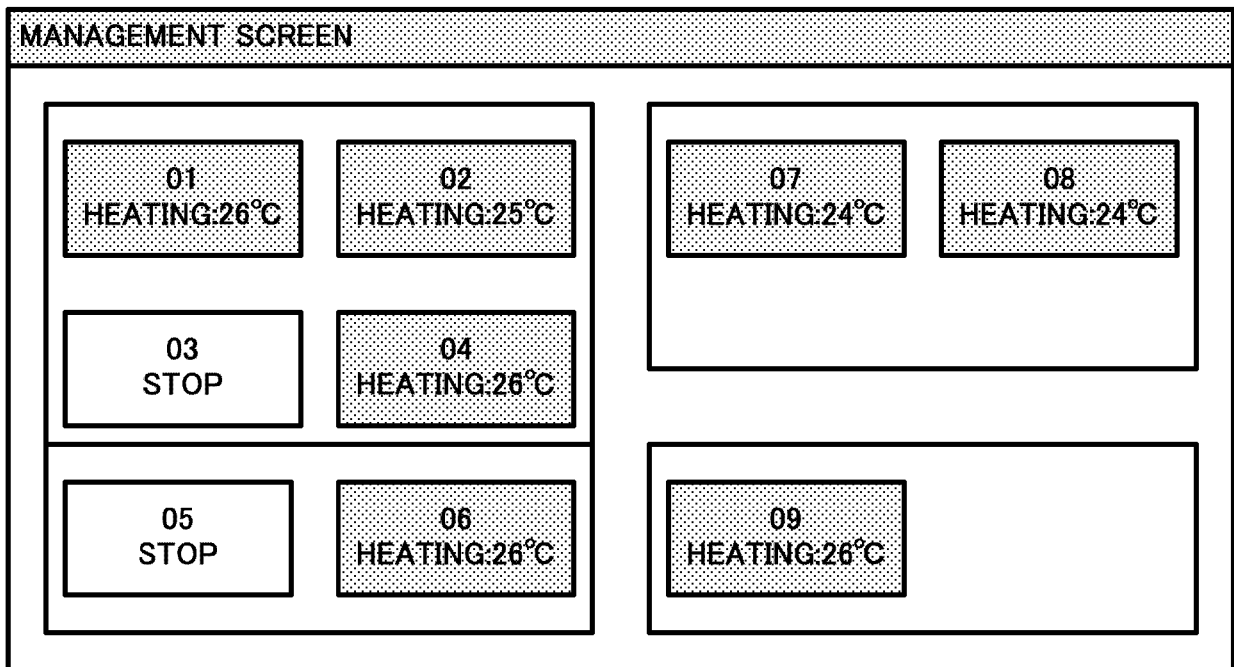
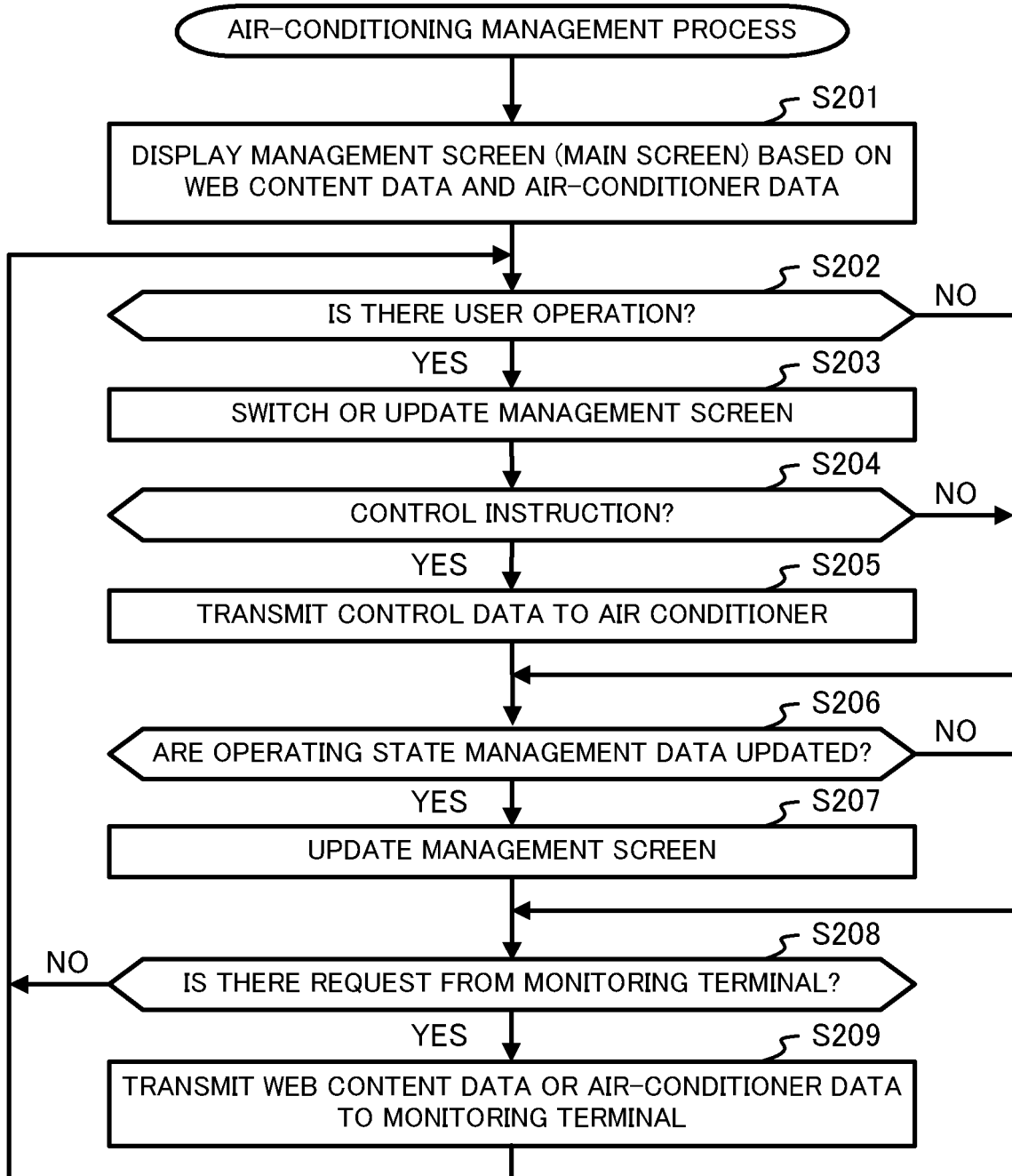

FIG. 7



REFERENCES CITED IN THE DESCRIPTION

This list of references cited by the applicant is for the reader's convenience only. It does not form part of the European patent document. Even though great care has been taken in compiling the references, errors or omissions cannot be excluded and the EPO disclaims all liability in this regard.

Patent documents cited in the description

- JP H10207527 A [0005]
- EP 2866149 A [0005]
- EP 2913776 A [0005]