

J. H. HANNON.
Cotton Plow and Planter.

No. 108,476.

Patented Oct. 18, 1870.

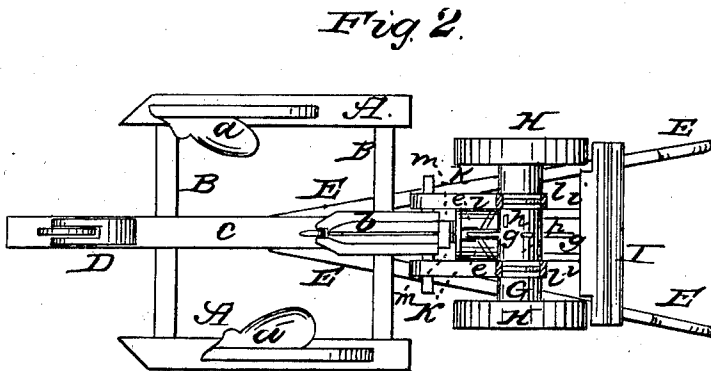
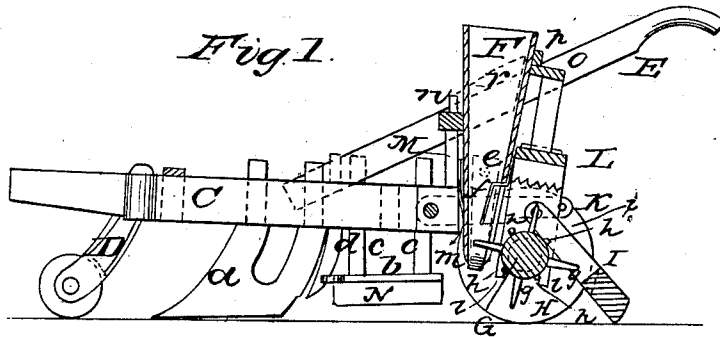

Witnesses
James L. Norris
W. H. Seuckel.

Inventor
John H. Hannon
by Frederick & Coris
attys

UNITED STATES PATENT OFFICE.

JOHN H. HANNON, OF HALIFAX, NORTH CAROLINA.

IMPROVEMENT IN COTTON PLOWS AND PLANTERS.

Specification forming part of Letters Patent No. 108,476, dated October 18, 1870.

To all whom it may concern:

Be it known that I, JOHN H. HANNON, of Halifax, in the county of Halifax and State of North Carolina, have invented a new and useful Improvement in Cotton Plows and Planters; and I do hereby declare the following to be a full, clear, and exact description thereof, sufficient to enable others skilled in the art to which my invention appertains to fully understand and use the same, reference being had to the accompanying drawing, forming part of this specification, in which drawing—

Figure 1 is a central longitudinal section of my device. Fig. 2 is a plan view of the bottom of the same.

Like letters of reference indicate corresponding parts.

My invention consists in a hopper which is suspended between the handles, and receives a vibratory motion by means of a spring operating against one side and rotating lugs against the other side.

It further consists in spring-jaws, which are located at the bottom of the hopper, and operate in connection with a spring placed above them, and with spikes, which are connected to a rotating shaft.

It also consists in the coverer, so arranged that it will also act as a scraper for the wheel.

Description.

A A in the drawing are longitudinal bars, secured to the main beam C by means of transverse pieces B B, which pass through the same, and are mortised with, or otherwise secured to, the bars A A. D is a caster-wheel, secured near the end of the center beam, and serves as a guide and support for the front part of the machine. E E are handles, fastened to the center beam. F is the hopper, supported between the handles E E and cross-pieces *n* and *o* and stops *p* and *r*, all secured on the handles.

A standard, M, is attached to the center beam, and passes through a cross-piece, *n*, which aids in supporting the said standards, and connects the handles together. A spring, *m*, is attached, at one end, firmly to the standard M, the other end being free, for a purpose to be hereafter explained.

From the cross-piece *o* standards L depend, the lower ends of which are cut out, or otherwise constructed, so as to form bearings for an axle, G, to which the wheels H H are se-

cured. Bolts or other fastenings may be used, and pass underneath the axle and through the ends *l l* of the standards L, and thus firmly secure the axle in place.

The axle G is made of wood or metal, and formed or provided with radiating arms or spikes *g g* around its periphery.

h h are lugs or projections, formed with or attached to the axle G, and may be arranged in an alternate or other suitable manner with reference to the radiating arms or spikes *g g*.

The hopper F is provided with spring-jaws *e e* at or near its mouth, which jaws converge or approach toward each other at their lower ends, thus forming a small opening, where the seed is retained until the same is acted upon by radiating arms or spikes *g g* upon the axle G.

A slot or opening is formed within the side of the hopper F, above which slot is secured, either upon the inside or outside of the hopper, as may be desired, a bent spring, *f*, in such a manner that when the spring is acted upon by the radiating arms or spikes entering the slot or opening, the spring will be forced inwardly and the seed retained in the hopper; but as the radiating arm or spike passes below the lower end of the spring, the seed will drop down into the opening formed by the spring-jaws *e e*, where it remains until acted upon by one of the radiating arms or spikes, when it is dropped upon the ground.

The radiating arms or spikes, as the axle G is revolved, come in contact with the spring *f*, and by thus agitating the seed in the hopper cause it to drop or fall out. The radiating arms or spikes, in their passage through the slot, carry out the seed which has lodged within the opening formed by the converging or approaching ends of the spring-jaws *e e*, and reliably depositing the seed upon the furrow formed within the ridge.

The lugs *h h*, secured upon or formed with the axle G, by which means the lugs are revolved through the medium of the wheels H H, striking against or coming in contact with the hopper, the same is forced against the spring *m* upon the standard M. The said spring, by its elasticity, thrusts back again the hopper, thus producing a continuous vibratory movement when the machine is being operated.

To the longitudinal bars A A plowshares *a* are secured in such a manner that these parts of the plowshares face each other. These plowshares may be arranged parallel with each other, and at points equidistant between the ends of the longitudinal beams, or may be attached so as to incline inwardly, and secured at different points on said beams, as may be desired.

The arrangement of these plowshares is such that the earth is thrown up and a ridge formed in the center between the said shares. As this ridge is continuously constructed, when the machine is in operation a furrow is formed in the ridge of a depth sufficient to protect the seed as the same is dropped upon the ground from the hopper through the medium of a colter or furrow-opener, *d*, and a follower, N, secured in a suitable manner to the main beam C.

The covering plate or bar is designated by the letter I, and is hinged or otherwise suitably attached, by the pivoted arms *i i*, to the standards L L, in such a manner that the said plate or covering-bar I may rise and fall, thus adapting itself to the inequalities of the land, and with any obstructions with which it might come in contact. This hinge plate or bar I is preferably made of a concave form on its under side, so as to snugly embrace or surround the ridge, and reliably cover all seed that is discharged or deposited upon the ground from the hopper F, as hereinbefore mentioned.

The follower N consists of the pieces *b b'*, secured together by bolts or screws, and is made, preferably, of cast-iron, although other material may be used, and at the same time I prefer to form the follower with the piece *b b'* and its arms or standards in one piece, of cast-iron or other suitable material, by which means it can be secured to the main beam, either stationary or adjustably, as may be desired, in a convenient and reliable manner.

d is the colter or furrow-opener, made of suitable iron or steel, and is secured adjustably, if it be desired, to the main beam C by bolts or clips at or near the front part of the

follower N, and, in the present instance, I have shown it as passing down through a suitable opening or slot in the follower-plate *b*, which slot or opening, by partly embracing or surrounding said colter or furrow-opener, will protect it from breakage or other injury, owing to the usage to which colters of plows in general are subjected.

The handles E E not only serve as a medium for operating and controlling the machine, but also assist in a great degree in aiding to support the standards with their covering apparatus, and the hopper with its operating mechanism.

It will thus be seen that I have produced a cotton plow and planter which can be readily constructed by any one. At the same time I dispense with complicated machinery, which is constantly getting out of order, thus affording to the public a machine which performs its function in a certain, reliable, and satisfactory manner by a contrivance, it is believed, not hitherto produced or devised.

Having thus described my invention, what I claim as new, and desire to secure by Letters Patent, is—

1. The suspended vibrating hopper F, in combination with the spring *m* and lugs *h*, when arranged and operating substantially as herein described.

2. The spring-jaws *e e* at the bottom of the hopper, when combined and operating in connection with the spring *f* above said jaws, and the arms or spikes *g*, substantially as described.

3. The coverer I, acting both as a coverer for the seed and a scraper for the wheels, substantially as described, for the purpose set forth.

The above signed by me this 25th day of May, 1870.

JOHN H. ^{his} × HANNON.
mark.

Witnesses:

J. W. SHEPPARD,
JOHN A. WIEDERSHEIM.