

(No Model.)

2 Sheets—Sheet 1.

# W. A. TURNER. FLUSHING VALVE.

No. 477,715.

Patented June 28, 1892.

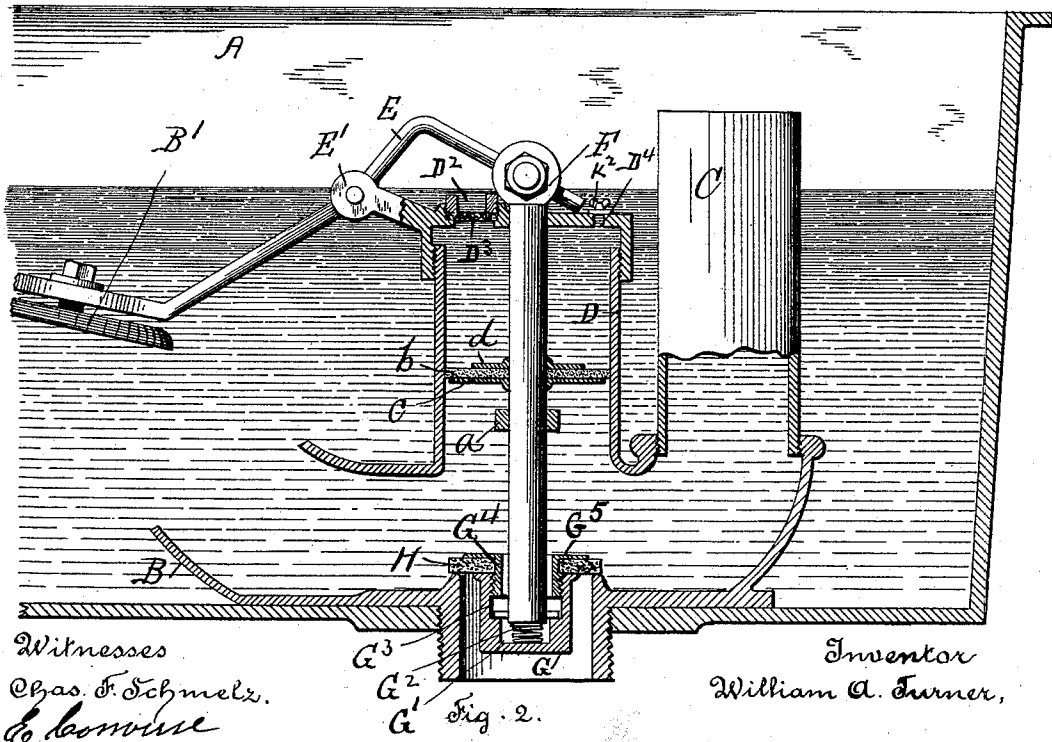
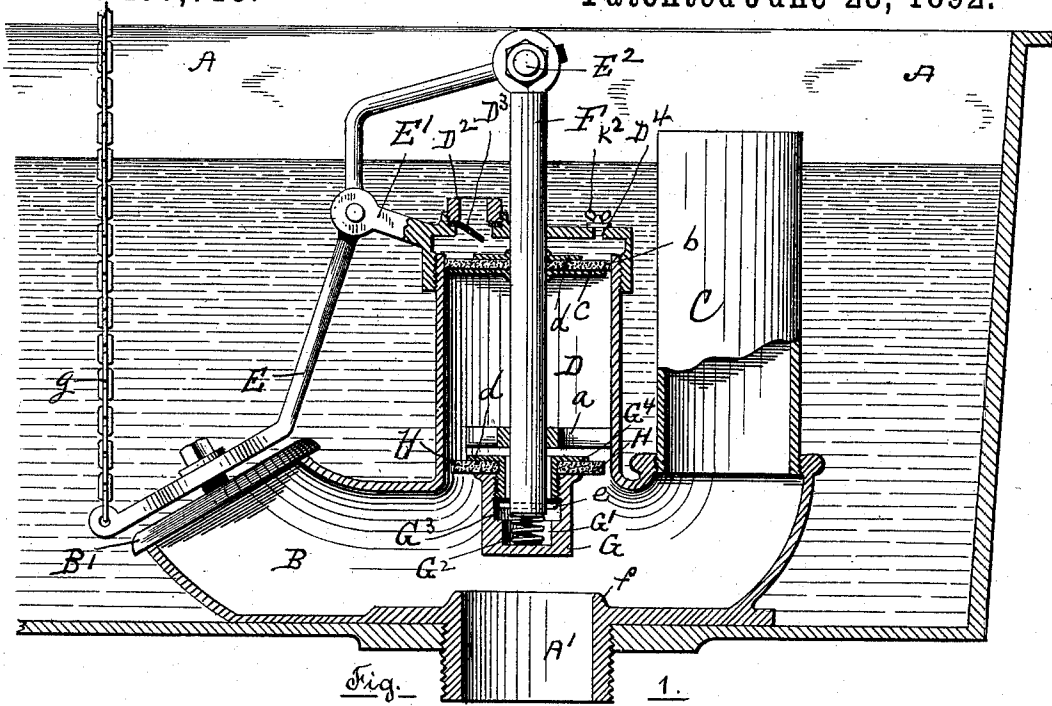

Witnesses  
 Chas. F. Schmelz.  
 C. L. Brown

Inventor  
 William A. Turner,

By his Attorney  
 Rufus B. Fowler.

(No Model.)

2 Sheets—Sheet 2.

W. A. TURNER.  
FLUSHING VALVE.

No. 477,715.

Patented June 28, 1892.

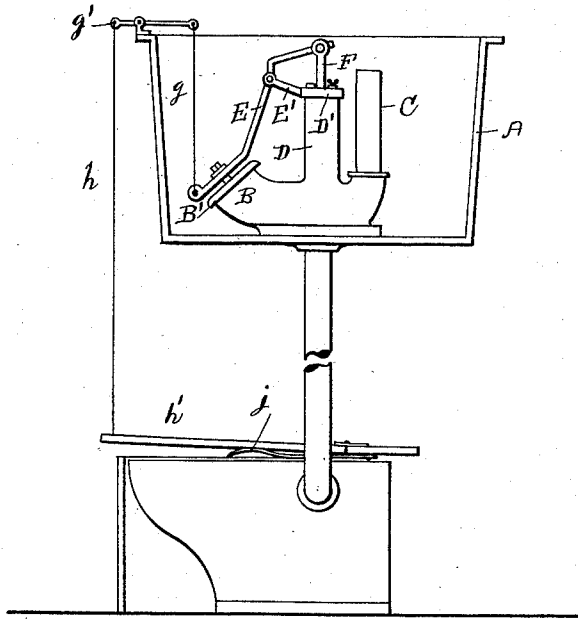

Fig. 3.

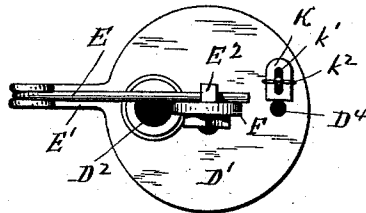

Fig. 4.

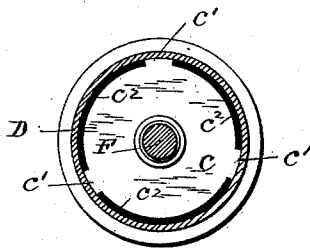

Fig. 5.

Witnesses  
F. H. Cutter.  
H. M. Fowler.

Inventor  
William A. Turner  
By Rufus B. Fowler  
atty.

# UNITED STATES PATENT OFFICE.

WILLIAM A. TURNER, OF WORCESTER, MASSACHUSETTS, ASSIGNOR TO  
EDMUND CONVERSE, OF SAME PLACE.

## FLUSHING-VALVE.

SPECIFICATION forming part of Letters Patent No. 477,715, dated June 28, 1892.

Application filed November 13, 1889. Serial No. 330,144. (No model.)

*To all whom it may concern:*

Be it known that I, WILLIAM A. TURNER, a citizen of the United States, and a resident of Worcester, in the county of Worcester and State of Massachusetts, have invented a new and useful invention relating to Improvements in Flushing-Valves, of which the following is a specification, reference being had to the accompanying drawings, forming a part of this specification, and in which—

Figure 1 represents a portion of a flushing-tank shown in sectional view and containing one of my improved flushing-valves represented in sectional view in order to disclose the interior operating parts, the valve being shown in a closed or normal position. Fig. 2 represents the same view of the same parts as are shown in Fig. 1, except that the valve is shown as open. Fig. 3 is a diagrammatic view of the valve-lever, closet-seat, and connecting parts by which the action of the valve as actuated by the seat-lid is illustrated. Fig. 4 is a top view of the cap which covers the cylinder D and shows the device by which the size of the outlet in the cap is enlarged or decreased, and also represents the swivel connection between the actuating-lever and the vertical valve-stem; and Fig. 5 is a transverse sectional view of the cylinder D and showing the form of the lower disk supporting the flexible piston.

Similar letters refer to similar parts in the several figures.

The object of my present invention is to provide the cisterns or flushing-tanks of water-closets with a flushing-valve, by which a small flow of water, known as a "forewash," shall be supplied to the closet before use and a definite and uniform flow or afterwash be supplied after use, constituting what is known as a "sure-supply valve" having both a "fore" and "after" wash, and I accomplish these objects by means of the mechanism illustrated in the accompanying drawings, in which—

A A denote a portion of the flushing-tank provided with an opening A' through its bottom, allowing the water in the tank to flow to a closet in the ordinary and usual manner. Above the opening A', I place the pipe B,

closed by a valve B', an overflow-pipe C, and a cylinder D, closed at the upper end by the cap D', through which is an opening D<sup>2</sup> to allow the water in the tank to flow into the cylinder D, and closed by a valve D<sup>3</sup>, preventing the escape of water from the cylinder D, except as it is forced through the small opening D<sup>4</sup> by the action of the operating mechanism, as hereinafter described.

The valve B' is connected to the lever E, which is pivoted upon the short arm E', projecting from the side of the cylinder or any rigid portion of the mechanism. The upper end of the pivoted lever E is passed through a hole in the oscillating block E<sup>2</sup>, journaled in the upper end of the valve-stem F, forming a swiveled connection between the valve-stem F and lever E. The valve-stem F is capable of a vertical sliding movement as actuated by the angular movement of the pivoted lever in bearings in the cap D' and bar a, held within the cylinder D, and to the central section of the valve-stem F, I attach the piston formed of the flexible disk b, held between the rigid disk c, having bearings c' c' c', resting against the sides of the cylinder, and between the bearing-edges c' a periphery c<sup>2</sup> c<sup>2</sup>, slightly smaller than the diameter of the flexible disk b and the rigid disk d, with its diameter considerably smaller than the diameter of the flexible disk b.

The lower end of the valve-stem F enters a cylindrical block G, having a concentric chamber G', containing the spiral spring G<sup>2</sup>, and above the chamber G' is an annular chamber G<sup>3</sup> to receive the ends of the pin e, held in the end of the valve-stem F. The block G is screw-threaded to receive a screw-threaded clamping-ring G<sup>4</sup>, having a flange G<sup>5</sup>, projecting over the inner edge of the valve-disk H, and by which it is firmly held against the block G. The spring G<sup>2</sup> bears against the end of the valve-stem F and the end wall of the chamber G', forcing the block G downward upon the valve-stem until it is held by the contact of the pin e and the lower edge of the ring G<sup>4</sup>.

Around the opening A' is an annular valve-seat f to receive the valve-disk H, thereby closing the opening A' to the passage of wa-

ter from the tank A. The lever E is connected by a chain *g* with a lever *g'*, which is connected by a chain *h* with the seat *h'*. The closet-seat *h'* is normally held in a slightly-  
 5 raised position, as represented in Fig. 3, by means of the spring *j*, and the valve B' is held in a closed position, as represented in Fig. 1, by its own gravity.

Upon the cap D' is placed a sliding plate  
 10 K, provided with a slot *k'* and held by a thumb-nut *k<sup>2</sup>*, for the purpose of reducing the size of the outlet-hole D<sup>4</sup>, through which water is forced from the cylinder D.

The operation of the valve is as follows:  
 15 The seat *h'* is lowered, compressing the spring *j* and through the connecting mechanism raising the valve B', allowing water to flow through the pipe B and opening A' to the closet. The operation of raising the valve B'  
 20 causes the valve-stem F to be moved downward, carrying the valve-disk H down upon the valve-seat *f*, closing the opening A' to the passage of water. The flow of water occurring between the opening of the valve B' and  
 25 the closing of the valve H constitutes the forewash. Upon the release of the seat the movement of the parts is reversed, the valve B' falls by its own gravity, closing the pipe B and raising the valve H to the position  
 30 shown in Fig. 1, the flow of water through the opening A' as the valve B' is closing constituting the afterwash. The valve B' is raised quickly by the depression of the seat *h'* and the flow of water during the raising of  
 35 the valve B' is comparatively small, but sufficient for the purpose of lubricating the sides of the closet-bowl J, the purpose of a forewash. During the closing of the valve B' a larger quantity of water is required, in order to properly flush the closet, and this is secured by  
 40 the slow closing of the valve B' by means of the retarding mechanism comprising the cylinder D and piston *b*, operating as follows: As the piston-disk *b* is moved down in the operation of opening the valve B' water flows  
 45 freely into the interior of the cylinder D through the opening D<sup>2</sup>, and as the motion of the piston is reversed by the closing of the valve B' the opening D<sup>2</sup> is closed by the  
 50 valve D<sup>3</sup>, obliging the water in the cylinder to escape through the restricted opening D<sup>4</sup>, the size of which is adjusted by means of the sliding plate K, and checking the speed of the valve B', the time required for the valve B'

to close being inversely to the size of the outlet-hole D<sup>4</sup>. The vertical depth of the annular chamber G<sup>3</sup> or distance between the lower end of the ring G<sup>4</sup> and the shoulder G<sup>5</sup> is sufficient to allow a slight movement of the block G and connected valve H upon the valve-stem F, in order to allow the valve-disk H to be brought into contact with its valve-seat with a yielding pressure for the purpose of reducing the jar incident to bringing the valve-disk suddenly against its seat.

I have shown and described my improved flushing-valve as being connected and operated by the closet-seat, as such method of operation is effective and convenient; but I do not confine myself to such means of operation, as any known method of operating flushing-valves can be employed, it only being necessary to raise the valve B' in order to secure the forewash and to maintain the valve B' open for such length as may be desired to elapse between the forewash and afterwash, and then to release the valve B' and allow it to close by its own weight.

I am aware that the closing of a flushing-valve has been heretofore retarded by causing a piston to traverse a cylinder and force the water contained in said cylinder in advance of its movement through a restricted opening or outlet. Such I do not claim, broadly.

What I do claim as of my invention, and desire to secure by Letters Patent, is—

The combination, with a flushing-tank, of the horizontal pipe B, valve B', and overflow-pipe C, placed at opposite ends of said pipe B, an outlet-opening A', extending downward from the central section of pipe B, a cylinder D, communicating with pipe B and closed at its top and provided with an inlet-valve D<sup>3</sup> and a variable outlet D<sup>4</sup>, said cylinder being in alignment with the outlet-opening A', valve-stem F, carrying a yielding valve H, arranged to close the outlet A', and a piston *b*, inclosed in said cylinder, and a bent lever E, carrying the valve B' and having a swiveled connection with the valve-stem F, substantially as described.

Dated at Worcester, in the county of Worcester and State of Massachusetts, this 11th day of November, 1889.

WILLIAM A. TURNER.

Witnesses:

E. CONVERSE,  
 RUFUS B. FOWLER.