



(22) Date de dépôt/Filing Date: 2000/05/29

(41) Mise à la disp. pub./Open to Public Insp.: 2001/11/29

(45) Date de délivrance/Issue Date: 2010/04/27

(51) Cl.Int./Int.Cl. *E21B 23/00* (2006.01),  
*E21B 33/10* (2006.01), *F04B 47/00* (2006.01),  
*F04C 13/00* (2006.01)

(72) Inventeurs/Inventors:  
HILL, DAVID A., CA;  
ALDRIDGE, COLIN A., CA

(73) Propriétaire/Owner:  
KUDU INDUSTRIES INC., CA

(74) Agent: BENNETT JONES LLP

(54) Titre : APPAREILLAGE DE RETENUE POUR POMPE DE CAVITE EN MOUVEMENT

(54) Title: HOLD DOWN APPARATUS FOR PROGRESSING CAVITY PUMP

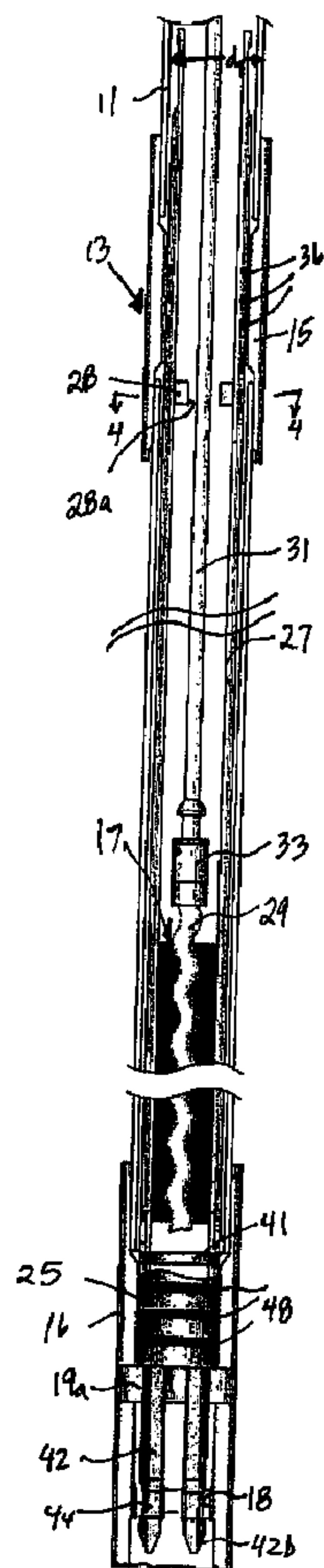

(57) Abrégé/Abstract:

A hold down apparatus is taught for a progressing cavity pump of the type having a stator, a helical rotor locatable in the stator and rotated by a string of rods, the pump being insertable in a bore of a tubing string by carriage on the rod string. The hold down

(57) **Abrégé(suite)/Abstract(continued):**

apparatus includes a sub connected to a lower end of the tubing, the sub having a bore open to the bore of the tubing string and including a pump-engaging member; and a hold down member at the lower end of the stator for insertion into the sub, the hold down member having a bore therethrough with a tag bar extending thereacross and including a tubing-engaging member for engaging with the pump-engaging member of the sub and for abutting against the pump-engaging member hold the stator against rotation relative to the sub

## ABSTRACT OF THE INVENTION

A hold down apparatus is taught for a progressing cavity pump of the type having a stator, a helical rotor locatable in the stator and rotated by a string of rods, the pump being insertable in a bore of a tubing string by carriage on the rod string. The hold down apparatus includes a sub  
5 connected to a lower end of the tubing, the sub having a bore open to the bore of the tubing string and including a pump-engaging member; and a hold down member at the lower end of the stator for insertion into the sub, the hold down member having a bore therethrough with a tag bar extending thereacross and including a tubing-engaging member for engaging with the pump-engaging member of the sub and for abutting against the pump-engaging member hold the stator  
10 against rotation relative to the sub

5

## Hold Down Apparatus for Progressing Cavity Pump

### Field of the Invention

This invention relates to progressing cavity pumps and, in particular, a progressing cavity pump moveable through production tubing in a well and a hold down apparatus for holding  
10 the pump in set position downhole.

### Background of the Invention

A progressing cavity pump is a well known pump, frequently called a "Moineau" pump, that has an elastomeric outer element or stator with a helical inner surface. A metal rotor having a helical exterior inserts within the stator.

15

Progressing cavity pumps of this type are used for many purposes, particularly for pumping viscous liquids. These pumps are also used as oil well pumps. When used as an oil well pump, the stator is secured to the lower end of the well tubing, then lowered into the casing of the well. The rotor is secured to the lower end of the sucker rod and lowered through the  
20 tubing to position the rotor inside the stator. The sucker rod is rotated by means of a rotary power source at the surface. U.S. Pat. No 2,267,459 shows one type of installation for an oil pump.

One disadvantage is that if the stator needs to be serviced, the string of tubing must be pulled.  
25 This is time consuming and requires special equipment. U.S. Pat. No. 3,347,169 shows a progressing cavity pump installation wherein the stator is lowered through the tubing on a flexible drive cable and secured by a seat.

U.S. Pat. No. 4,592,427 shows a progressing cavity pump installation that is lowered through  
30 the tubing on sucker rods and secured by a seating nipple and torque reactor cup arrangement.

### Summary of the Invention

The progressing cavity pump of the present invention is lowered through the production tubing on a rod string. The pump is releasably latched down hole and held against rotation. A hold down apparatus provides for correct positioning of the rotor within the stator of the pump.

5

In accordance with a broad aspect of the present invention, there is provided in a hold-down apparatus for a progressing cavity pump of the type having a stator, a helical rotor locatable in the stator and rotated by a string of rods, the pump being insertable in a bore of a tubing string by carriage on a rod string, the hold-down apparatus comprising: a sub connected to a lower end of the tubing, the sub having a bore open to the bore of the tubing string and including a pump-engaging member; and a hold down member at the lower end of the stator for insertion into the sub, the hold down member having a bore therethrough with a tag bar extending thereacross and including a tubing-engaging member for engaging with the pump-engaging member of the sub and for abutting against the pump-engaging member to hold the stator against rotation relative to the sub.

10  
15

The tubing-engaging member and the pump-engaging member are adapted to coact to engage the hold down member to the sub. In one embodiment, the pump-engaging member is any member that provides for positive engagement between the hold down member and the sub. In one embodiment, the pump-engaging member is an annular raised portion formed to releasably engage the tube-engaging member which is an annular recess on the hold down member. To facilitate engagement between the annular recess and the annular raised portion, the tubing-engaging member is preferably a collet including a plurality of spaced-apart fingers, each finger having a recess formed thereon adapted to engage over the annular raised portion. The pump-engaging member can further include a projection extending into the bore of the bore of the sub. The projection is adapted to fit between the fingers and act as a stop wall against which the fingers abut to prevent rotation of the tubing-engaging member within the pump-engaging member.

20

25

The hold down apparatus can further include a seal for sealing between the sub and the hold down member to prevent passage of fluid therebetween. In one embodiment, the hold down apparatus includes an upper seal positioned above the stator and adapted to seal between the stator, or an extension thereof, and the tubing. The upper seal seals against passage of fluids and also prevents material, such as formation solids, from becoming jammed between the stator and the tubing string inner wall.

### **Brief Description of the Drawings**

A further, detailed, description of the invention, briefly described above, will follow by reference to the following drawings of specific embodiments of the invention. These drawings depict only typical embodiments of the invention and are therefore not to be considered limiting of its scope. In the drawings:

Figure 1 is a vertical section through a portion of production tubing including in a set position therein a progressing cavity pump according to the present invention and shown in a partially cut away configuration and with the rotor in pumping position within the stator;

Figure 2 is a view of the tubing and progressing cavity pump of Figure 1 with the rotor removed from the stator and in flush-by position for pulling uphole;

Figure 3 is a sectional view along line 3-3 of Figure 1;

Figure 4 is a sectional view along line 4-4 of Figure 1;

Figure 5 is a vertical section through a pump hold down member useful in the present invention; and

Figure 6 is a vertical section through a tubing hold down sub useful in the present invention.

### **Description of the Preferred Embodiments of the Invention**

Referring to Figures 1 and 2, a portion of a string of production tubing is generally indicated at 11. Tubing 11 extends in a well usually through casing (not shown). A PCP pump hold down section of tubing, generally indicated at 13, is secured at the lower end of the tubing.

5 Section 13 includes a tubing seal sub 15 and a tubing-engaging hold down sub 16 connected by a string of tubing 11a. Section 13 is formed to releasably engage and form a seal about a progressing cavity pump 17 (shown in the set position in Figures 1 and 2). The subs 15 and 16 and tubing strings 11 and 11a are connected in any durable way such as, for example, by standard threaded connections.

10 Tubing seal sub 15 and tubing hold down sub 16 are each formed with a diameter that is less than the diameter  $d_1$  of tubing 11 and about the same size or slightly larger than the outer diameter of pump 17. Referring for greater detail to Figures 3 and 6, tubing hold down sub 16 includes an annular raised portion 18 having an upper ramped shoulder 18a and a lower stop shoulder 18b. Raised portion 18 acts to hold the pump down in position in tubing

15 section 13, as will be described hereinafter. Anti-rotation projections 19a, 19b are mounted, as by welding, in the bore of tubing hold down sub 16. Anti-rotation projection 19a is formed as a bar that extends across the bore of tubing hold down sub 16. Projections 19b extend out a short distance into the bore of sub 16. The projections must withstand significant shearing forces and therefore are preferably welded in ports 16a formed through

20 the wall of tubing sub 16. Anti-rotation projections 19a, 19b act to prevent rotation of the pump when it is engaged in the tubing section 13 and assist in the positioning and support of the pump, as will be described hereinafter.

Pump 17 includes a stator 20, which is elastomeric and has a helical inner bore 21. A hold-down member 25 is secured to the lower end of stator 20, while the upper end of stator 20 is

25 secured to a flush-by housing 27.

Flush-by housing 27 is a tubular member with an outer diameter approximately equal to that of stator 20. Flush-by housing 27 includes a collar 28 at the upper end thereof. Collar 28 is mounted in flush-by housing, for example, by threaded engagement, welds or by being formed

integral therewith. Referring also to Figure 4, collar 28 defines a central aperture 28a therethrough.

The pump's helical rotor 29 and stator 20 are of conventional design. Rotor 29 is adapted to be located in the stator and has a length greater than that of the stator. Rotor 29 is connected to a rod string 31 by a pick-up coupling 33. Rod string 31 is of a conventional design such as, for example, including a plurality of rigid sucker rods extending to surface or a continuous rod. Rod string 31 extends loosely through aperture 28a providing clearance for well fluids to be pumped through the aperture. Coupling 33 is larger in diameter than the minimum diameter across aperture 28a and, therefore, cannot pass therethrough. Rotor 29 can be moved by rod string 31 between a position within the stator and a position within the flush-by housing 27 but is prevented from being removed from the flush-by housing 27 by abutment of coupling 33 against collar 28. Flush-by housing 27 is of a length to permit rotor 29 to be fully withdrawn from stator bore 21.

Seals 36, such as O-rings, are mounted about outer surface of flush-by housing 27 and are sized such that they will seal against inner surface of tubing seal sub 15. Seals 36 prevent formation solids from migrating down and becoming jammed between the pump and tubing 13. The upper end of flush-by housing 27 has formed thereon a fishing profile 38 for engagement by a fishing tool (not shown), should that be required.

Hold down member 25 is attached at the lower end of stator 20 and has a bore 40 therethrough for passage of well fluids. A tag bar 41, which can be formed as a bar or plate, extends across bore 40, while permitting passage of fluids therepast through the bore. Tag bar 41 is a known distance from stator 20 and permits proper positioning of rotor 29 within stator.

Referring also to Figure 5, hold down member 25 includes a collet having four fingers 42. Each finger has a recess 44 formed on its outer surface. Together the recesses 44 form an annular recess on the collet adapted to engage over annular raised portion 18. Fingers 42 each have tapered leading edges 42a that facilitate passing over the raised portion. However, recesses 44 each have an angular shoulder 44a that engages against the lower shoulder 18b of raised portion

18, creating resistance to fingers 42 being pulled upwardly out of engagement with the raised portion.

Fingers 42 are spaced apart and therebetween define slits 46. Slits 46 are sized to accommodate anti-rotation projections 19a, 19b. Sides 42b of the fingers are inclined to facilitate movement of  
5 fingers 42 past the projections.

Seals 48, such as O-rings, are mounted about the outer surface of hold down member 25. The seals are sized such that they will seal against inner surface of tubing hold down sub 16.

As will be appreciated, hold down member 25 and seals 36 of the flush-by housing are spaced apart a distance selected to correspond with the distance between tubing seal sub 15 and tubing  
10 hold down sub 16.

In use, section 13 is secured to the lower end of a tubing string 11 and the entire string is lowered into a well. After the tubing 11 is positioned, pump 17 is lowered into the tubing. Pump 17 is assembled with hold down member 25 mounted below the stator and flush-by housing 27 mounted above the stator. Rotor 29 is positioned in flush-by housing 27 and connected by pick-  
15 up coupling 33 to rod string 31. Pump 17 is supported on rod string 31 with collar 28 and pick-up coupling 33 contacting each other. Pump 17 is then lowered on the rod string through tubing string 11 into the well. While being lowered into the well, rotor 29 is positioned within flush-by housing and does not extend into bore 21 of the stator. Thus, as pump 17 moves through the tubing, well fluids can pass up through bore 40 of the hold down member, bore 21, the bore of  
20 flush by housing 27 and out through aperture 28a.

When the pump 17 reaches section 13, seals 48 will pass through the restricted diameter of tubing seal sub 15. Relatively little force is required to do this and generally the weight of the stator 20, flush-by housing 27 and member 25 will move seals 48 past sub 15. However, if necessary, the rotor 29 can be pushed against tag bar 41 to force the pump through the tubing.

25 Once seals 48 are past sub 15, fingers 42 will eventually contact projections 19a, 19b. Inclined edges 42b will cause member 25 and the pump 17 and housing 27 connected thereto to rotate

such that fingers pass through the open space between the projections. Member 25 will continue to move down until leading ends 42a of finger pass over raised portion 18 and recesses 44 become engaged over the raised portion. In this position, shoulders 44a are engaged under the lower shoulder of raised portion 18. When this occurs, the pump is in the set position wherein force is required to pull the member 25 out of engagement with the hold down sub 16 and pump is prevented from rotating by abutment of fingers 42 against projections 19a, 19b. Seals 36 and 48 are sealed against the inner surfaces of subs 15 and 16, respectively, sealing against passage of fluids and preventing materials from becoming jammed between housing 27 and sub 15. It will be appreciated that the hold down apparatus is best supported if projections 19a, 19b are spaced from raised portion 18 such that when recesses 44 are engaged over raised portion 18, member 25 is supported on bar 19a. This arrangement is further preferred as it permits positive placement of recesses 44 over raised portion 18 without reliance on sensing small changes in string weight at surface.

It will be appreciated that other engaging arrangements between the fingers and the sub can be used. For example, instead of raised portion 18 an annular recess can be used which is engaged by projections on the fingers.

Once pump 17 is seated within section 13, rod string 31 is lowered to move rotor 29 into bore 21 of the stator. Rotor 29 is lowered until it abuts against tag bar 41 at which point the exact position of the rotor with respect to the stator is known. The rotor is then raised a selected distance above tag bar 41 as required to move coupling 33 sufficiently above stator 20, with consideration as to rod stretch, to prevent the coupling from abutting against, and thereby damaging, the stator. Rod string 31 is then connected to a rotary power source (not shown) for rotation.

When the string 31 rotates, it rotates rotor 29 to cause fluid to flow through hold down member 25, bore 21, housing 27 and aperture 28a. Undesirable rotation of pump 17 during rod string rotation is avoided by abutment of collet fingers 42 against projections 19a, 19b.

When it becomes necessary to pull the pump for maintenance, the string 31 is uncoupled from the motor at the surface. Then string 31 is raised to cause pick-up coupling 33 to go up and abut against collar 28. Continued upward force then dislodges collet fingers 42 from engagement with annular raised portion 18. As an example, in one embodiment of the invention useful for 5 3½" tubing, a string weight of 150 lbs. is useful to set the pump in the tubing string, while a force of 20,000 lbs. is needed to unseat the pump.

Seals 36, 40 will also release from their seating position against subs 15 and 16. Once dislodged, the pump 17 is pulled to surface on rod string 31. Tubing 11 and section 13 remain in the well.

10 Since it is desired to leave the tubing string downhole for long periods, the tubing string components are preferably formed of durable materials. Preferably the raised portion 18 is treated as by boronizing to increase its hardness and durability over the steel used in the remainder of the tubing string and subs and over the steel used for hold down member 25. To reduce scaling and damage to the sub surfaces against which the seals are positioned, preferably, these surfaces are polished and hardened as by chroming.

15 It will be apparent that many other changes may be made to the illustrative embodiments, while falling within the scope of the invention and it is intended that all such changes be covered by the claims appended hereto.

THE EMBODIMENTS OF THE INVENTION IN WHICH AN EXCLUSIVE PROPERTY OR PRIVILEGE IS CLAIMED ARE DEFINED AS FOLLOWS:

1. A hold-down apparatus for a progressing cavity pump of the type having a stator in a stator housing, a helical rotor locatable in the stator and rotated by a string of rods and an upper housing extending above the stator housing for accommodating the helical rotor out of the stator, the pump being insertable in a bore of a tubing string by carriage on the rod string, the hold-down apparatus comprising: a sub connected to a lower end of the tubing string, the sub having a bore open to the bore of the tubing string to form a tubing string inner wall and including a pump-engaging member; a hold down member at the lower end of the stator for insertion into the sub, the hold down member having a bore therethrough and including a tubing-engaging member for engaging the pump-engaging member of the sub; and an upper annular seal positioned above the stator and adapted to seal between the upper housing and the tubing string inner wall.
2. The hold-down apparatus of claim 1 further comprising a tubing seal sub carried on the tubing string and installed above the pump-engaging member, the tubing seal sub including an inner wall against which the upper seal seals.
3. The hold-down apparatus of claim 2 wherein the tubing seal sub includes an inner diameter dimension less than the tubing string inner diameter.
4. The hold-down apparatus of claim 2 wherein the tubing seal sub inner wall is chromed.
5. The hold-down apparatus of claim 2 wherein the tubing seal sub inner wall is polished.
6. The hold-down apparatus of claim 1 further comprising a first annular sealing surface along the tubing string and a second annular sealing surface spaced below the first annular sealing surface, the first annular sealing surface including an inner diameter against which the upper seal seals.
7. The hold-down apparatus of claim 6 wherein both of the first annular sealing surface and the second annular sealing surface are positioned above pump hold down member.

8. The hold-down apparatus of claim 6 wherein both of the first annular sealing surface and the second annular sealing surface are chromed.
9. The hold-down apparatus of claim 6 wherein both of the first annular sealing surface and the second annular sealing surface are polished.
- 5 10. The hold down apparatus of claim 1 further comprising a lower annular seal for sealing between the tubing string inner wall and the hold down member to prevent passage of fluid upwardly therebetween.
11. The hold-down apparatus of claim 1 wherein the upper housing defines along its length a flush-by housing and the upper annular seal is positioned about the flush-by housing.
- 10 12. The hold-down apparatus of claim 1 wherein the upper annular seal includes at least one o-ring carried on the progressing cavity pump.
13. The hold-down apparatus of claim 1 further comprising a tag bar.
14. The hold down apparatus of claim 1 wherein the pump-engaging member is an annular raised portion formed to releasably engage the tubing-engaging member, the tube-engaging member being a collet including a plurality of spaced-apart fingers, each finger having a recess formed thereon adapted to engage over the annular raised portion.
- 15 15. The hold down apparatus of claim 14 wherein the pump-engaging member further includes a projection extending into the bore of the sub, the projection being adapted to fit between the fingers and act as a stop wall against which the fingers abut to prevent rotation of the tubing-engaging member within the pump-engaging member.
- 20 16. A hold-down apparatus for a progressing cavity pump of the type having a stator in a stator housing and a helical rotor locatable in the stator and rotated by a string of rods, the pump being insertable in a bore of a tubing string by carriage on the rod string, the hold-down apparatus comprising: a sub connected to a lower end of the tubing, the sub having a bore open to the bore of the tubing string and including a pump-engaging member having an annular raised portion; and a hold down member at the lower end of the stator for insertion into the sub, the hold down member having a bore therethrough and including a tubing-engaging member having a plurality of recesses for engaging over the annular raised portion of the pump-engaging member of the sub
- 25 30

and for abutting against the pump-engaging member to hold the stator against rotation relative to the sub.

- 5 17. The hold down apparatus of claim 16 wherein the tube-engaging member comprises a collet including a plurality of spaced-apart fingers, each finger having a recess formed thereon adapted to engage over the annular raised portion.
18. The hold down apparatus of claim 17 wherein the pump-engaging member further includes a projection extending into the bore of the sub, the projection being adapted to fit between the fingers and act as a stop wall against which the fingers abut to prevent rotation of the tubing-engaging member within the pump-engaging member.
- 10 19. The hold down apparatus of claim 16 further comprising a seal for sealing between the sub and the hold down member to prevent passage of fluid therebetween.
20. The hold down apparatus of claim 16 further comprising an upper seal positioned above the stator and adapted to seal between the stator, or an extension thereof, and the tubing.
- 15 21. The hold down apparatus of claim 16 further comprising a tubing seal sub carried on the tubing string and installed above the pump-engaging member, the tubing seal sub including an inner wall against which the upper seal seals.
22. The hold down apparatus of claim 21 wherein the tubing seal sub includes an inner diameter less than the tubing string inner diameter.
- 20 23. The hold down apparatus of claim 16 further comprising a first annular sealing surface along the tubing string and a second annular sealing surface spaced below the first annular sealing surface, the first annular sealing surface including an inner diameter against which the upper seal seals.

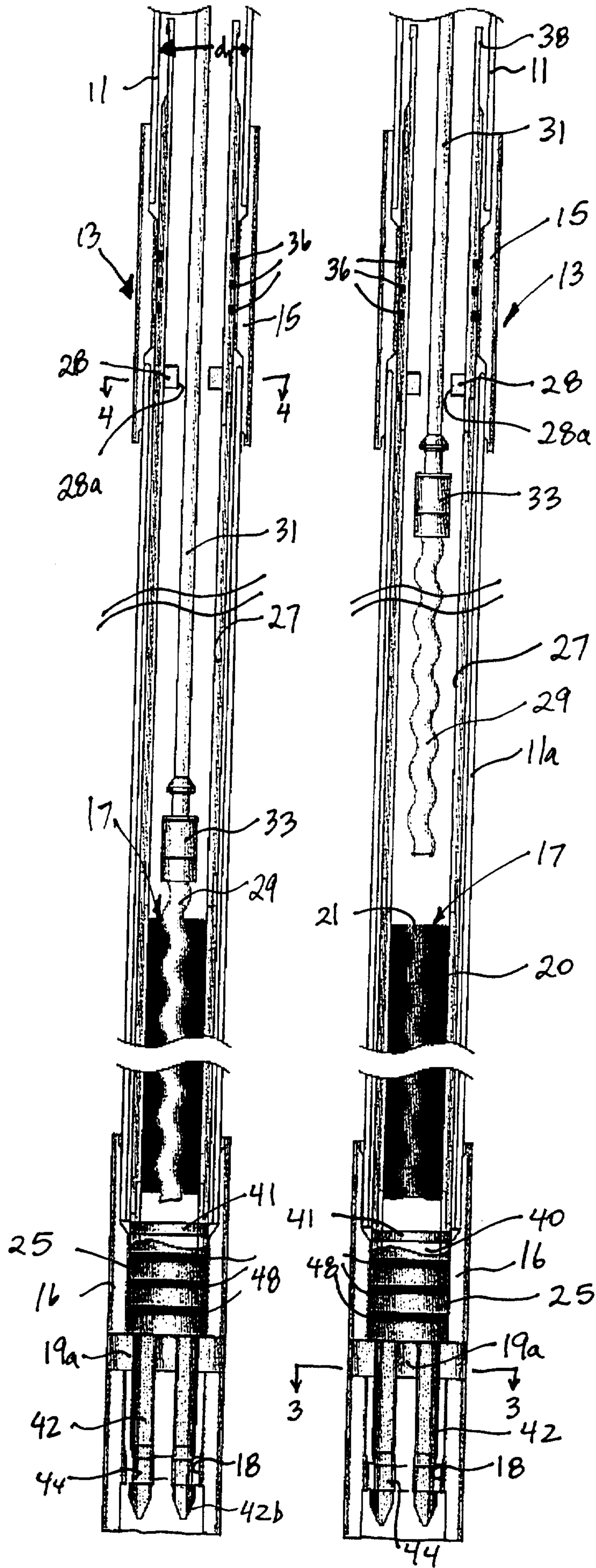

Figure 1

Figure 2

Figure 4

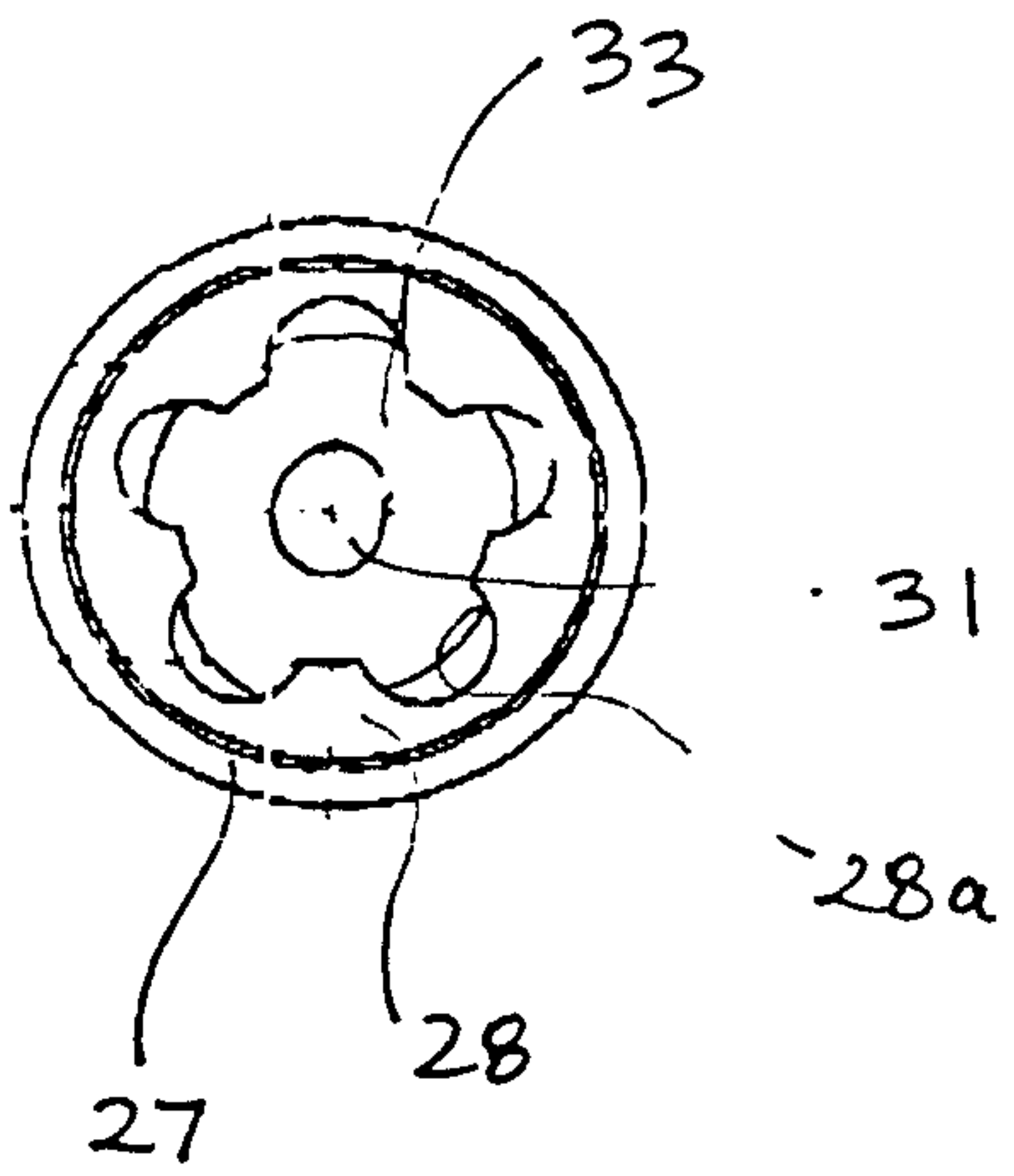

Figure 5

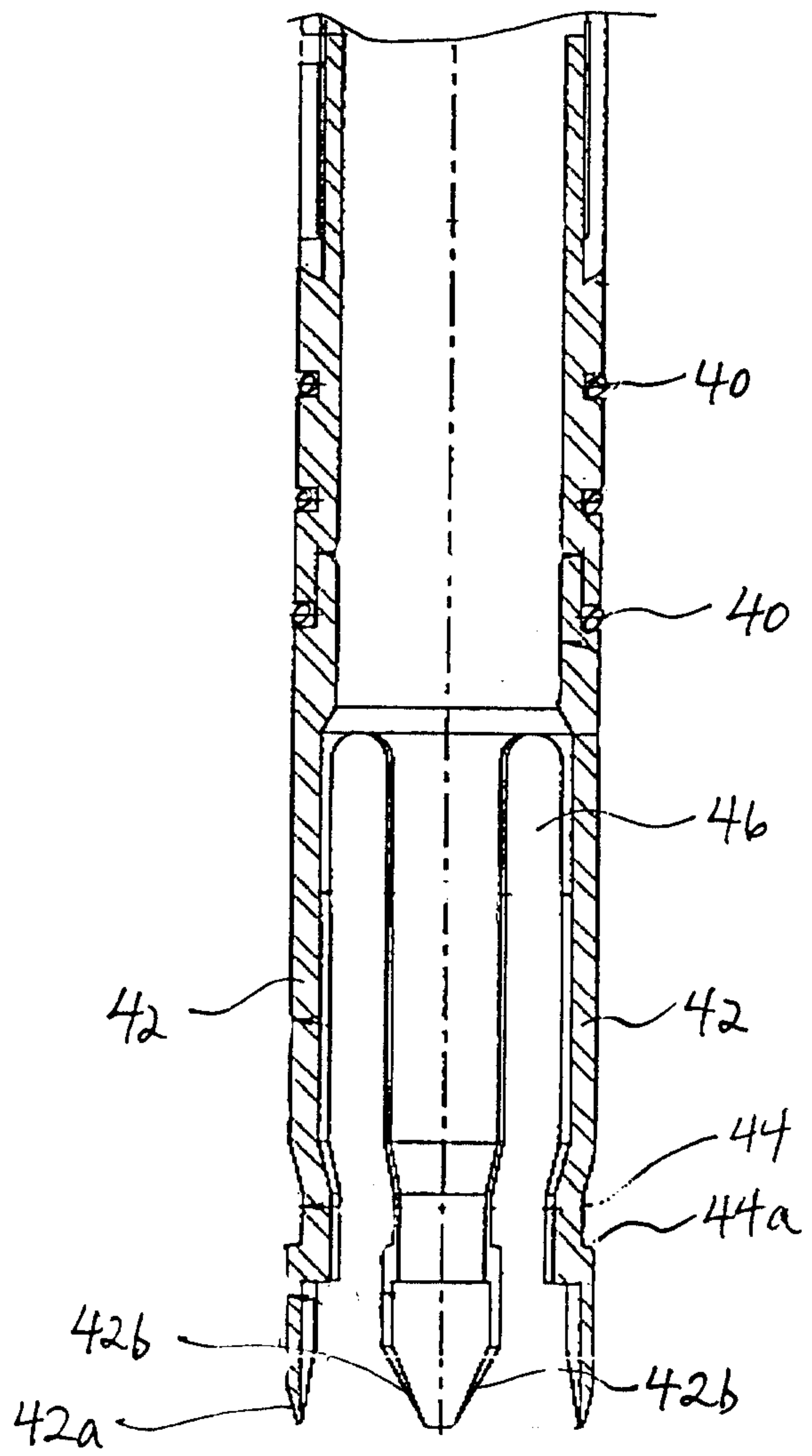

Figure 6

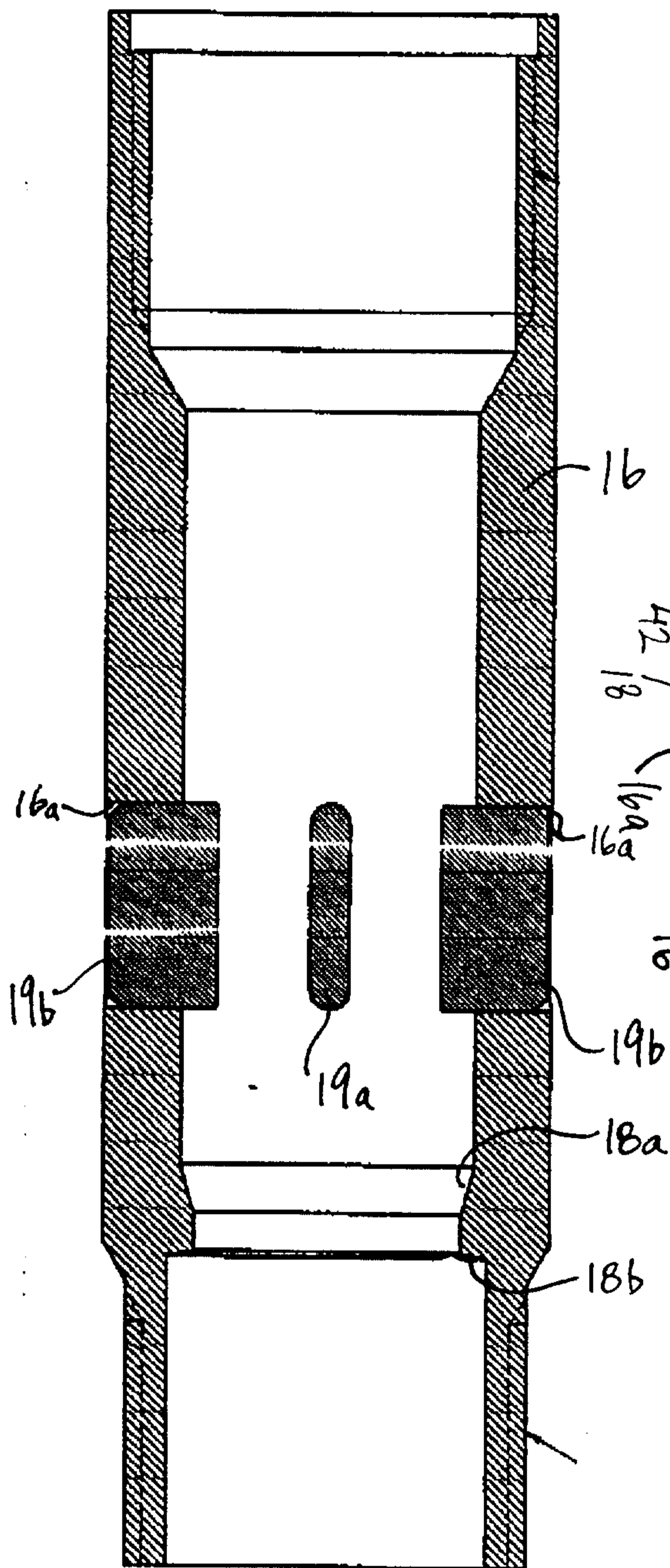

Figure 3

