

H. JOHNSON.

APPARATUS FOR OPERATING RAILWAY SIGNALS.

No. 343,320.

Patented June 8, 1886.

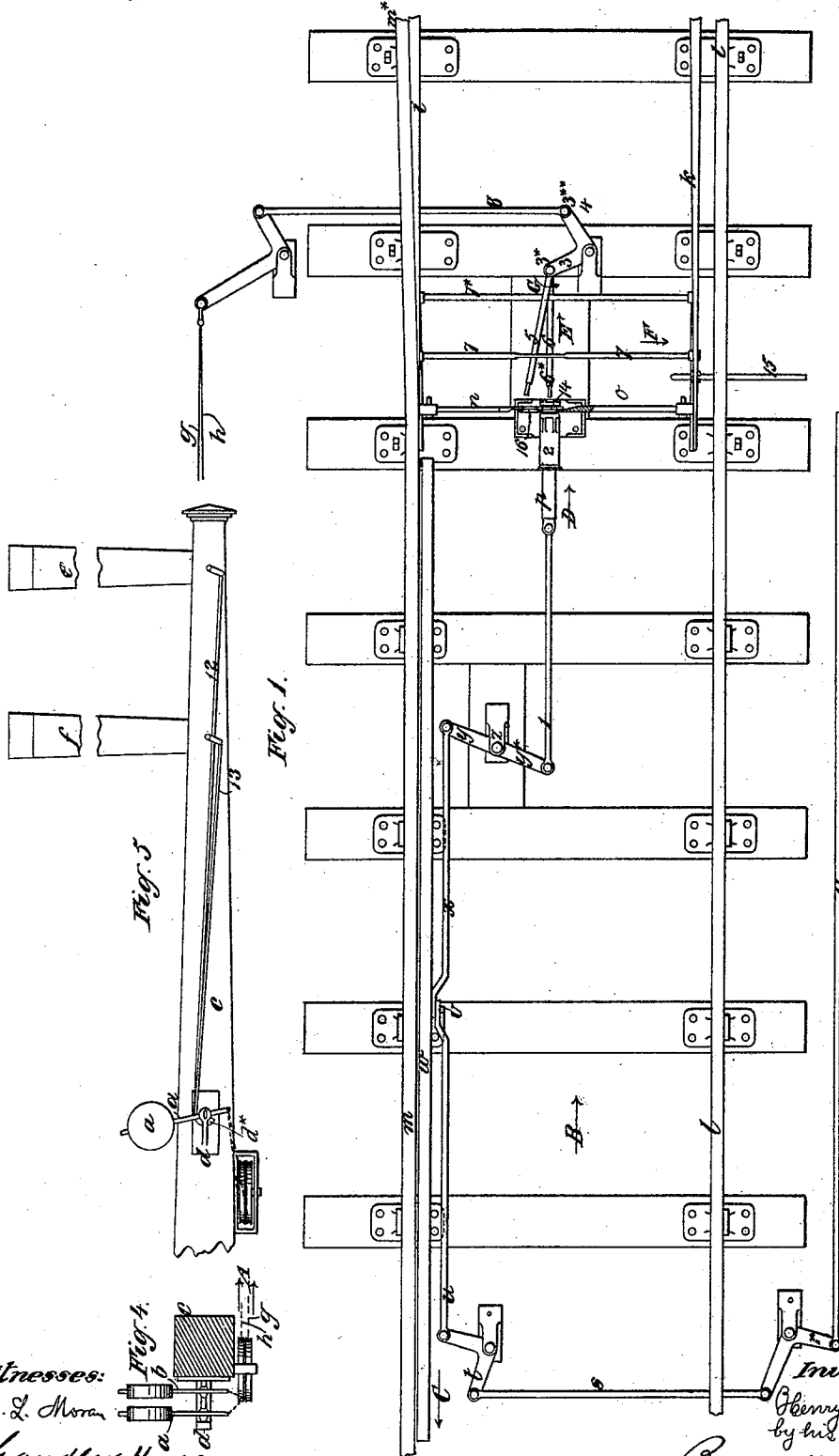

Fig. 5.

Fig. 1.

Fig. 4.

Witnesses:
 Ed. L. Moran
 Chandler Hall

Inventor:
 Henry Johnson
 by his Attorneys
 Brown & Hall

H. JOHNSON.

APPARATUS FOR OPERATING RAILWAY SIGNALS.

No. 343,320.

Patented June 8, 1886.

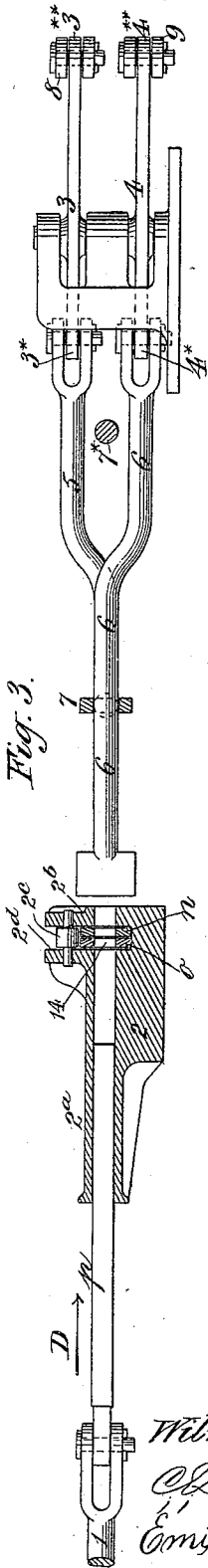

Fig. 3.

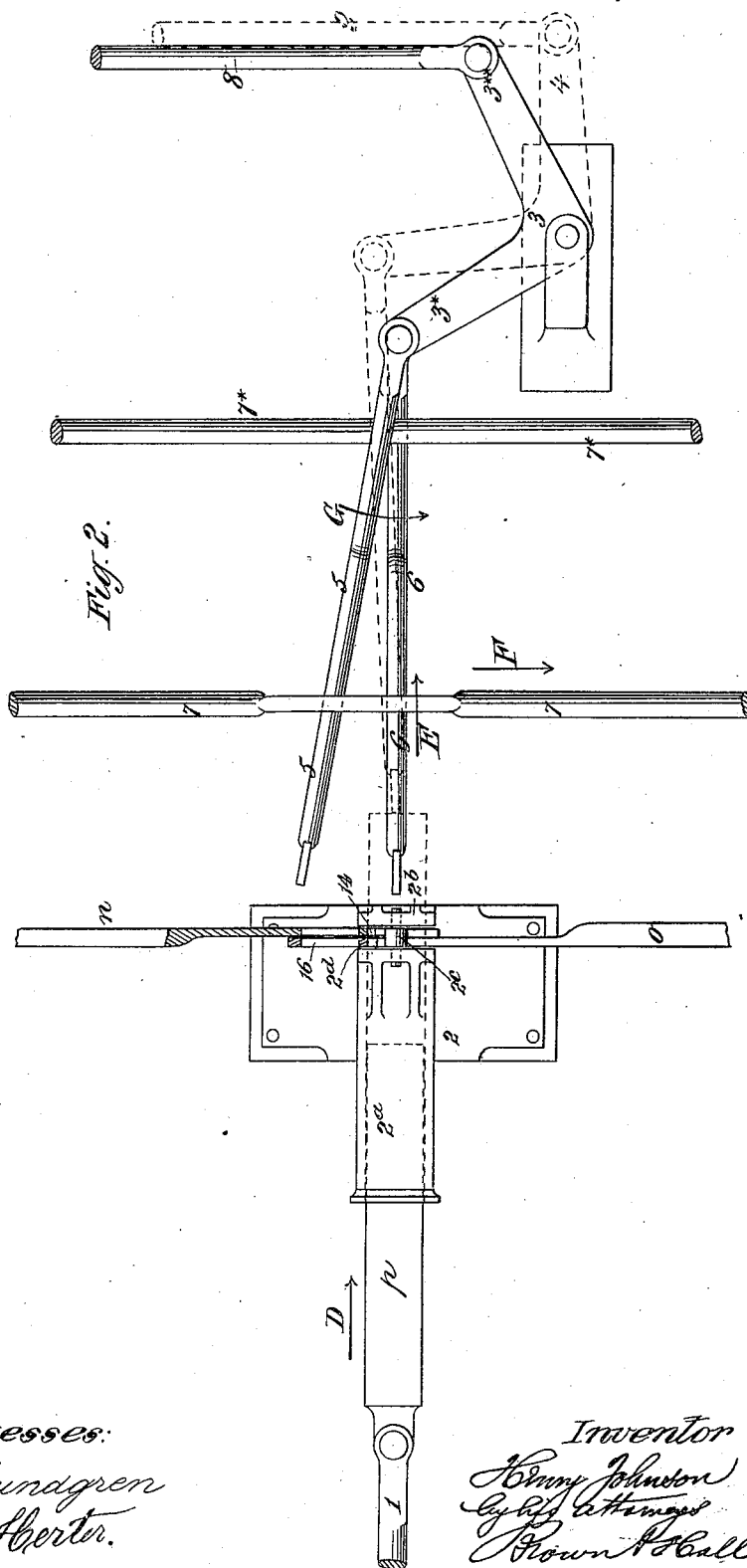

Fig. 2.

Witnesses:
O. Sundgren
Emil Hertel

Inventor
Henny Johnson
Clyde Attmore
Rowen A. Hall

H. JOHNSON.

APPARATUS FOR OPERATING RAILWAY SIGNALS.

No. 343,320.

Patented June 8, 1886.

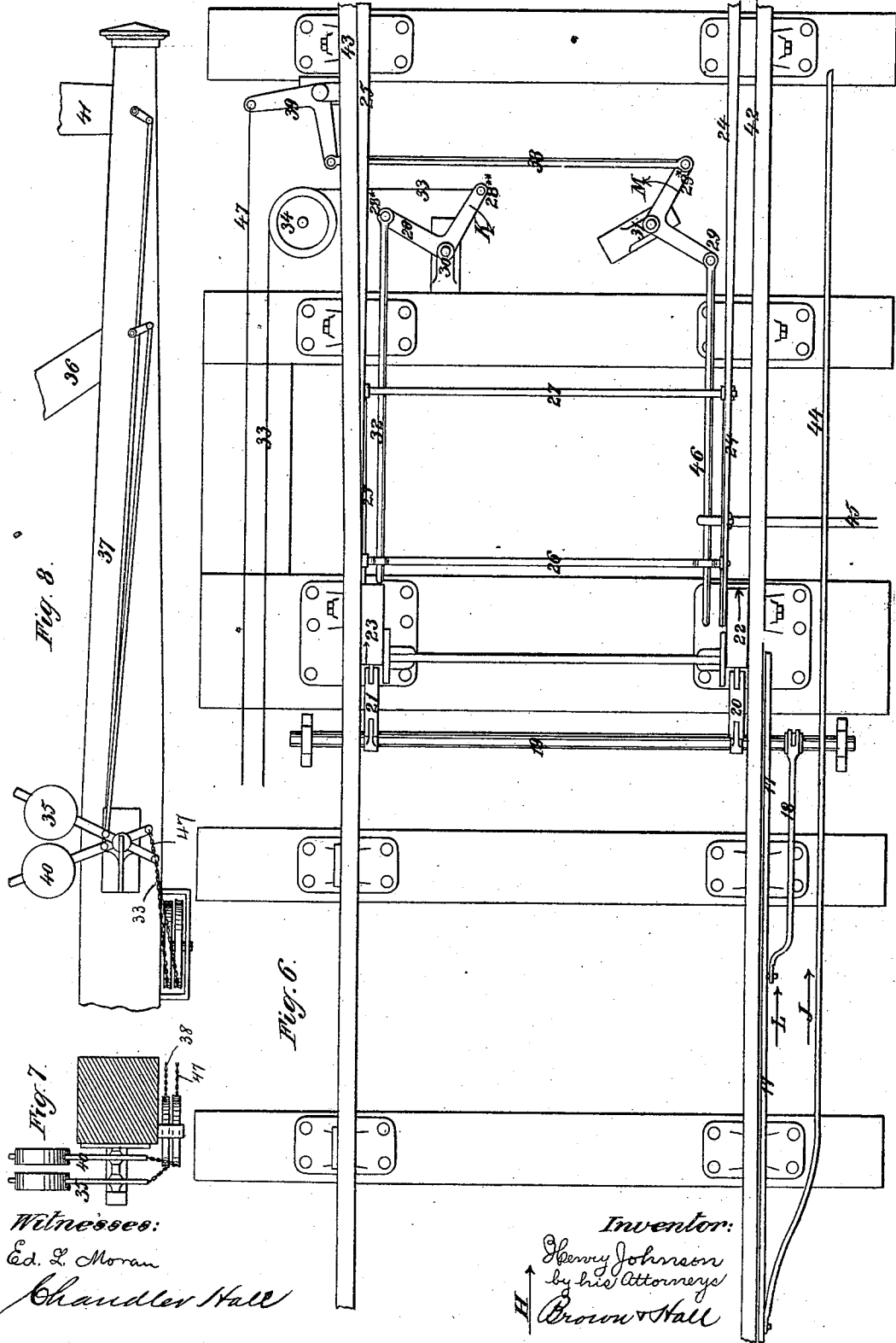

Witnesses:
 Ed. L. Moran
 Chandler Hall

Inventor:
 Henry Johnson
 by his Attorneys
 Brown & Hall

H. JOHNSON.

APPARATUS FOR OPERATING RAILWAY SIGNALS.

No. 343,320.

Patented June 8, 1886.

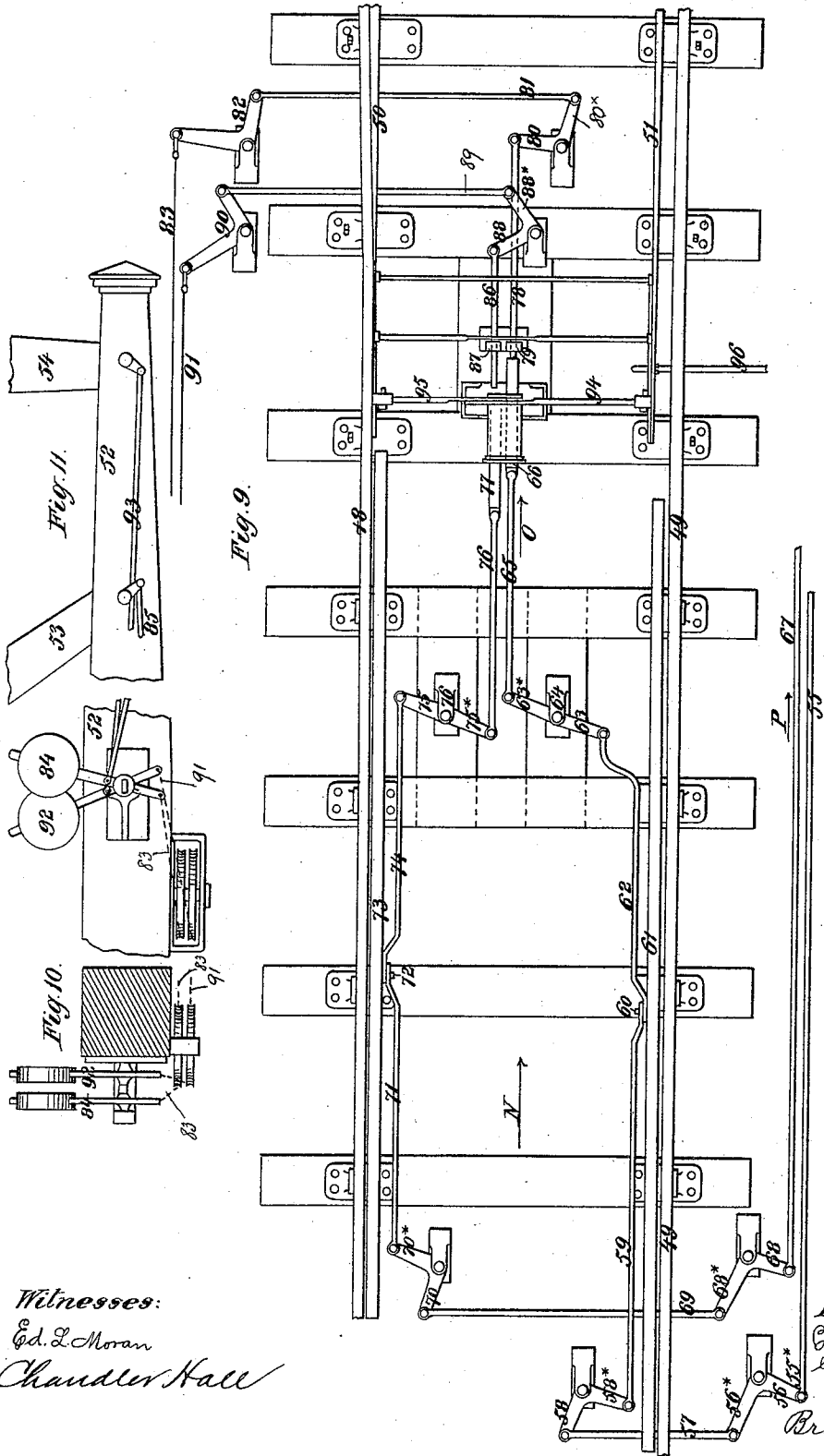

Witnesses:
 Ed. L. Moran
 Chandler Hall

Inventor:
 Henry Johnson
 by his Attorneys
 Brown Hall

H. JOHNSON.

APPARATUS FOR OPERATING RAILWAY SIGNALS.

No. 343,320.

Patented June 8, 1886.

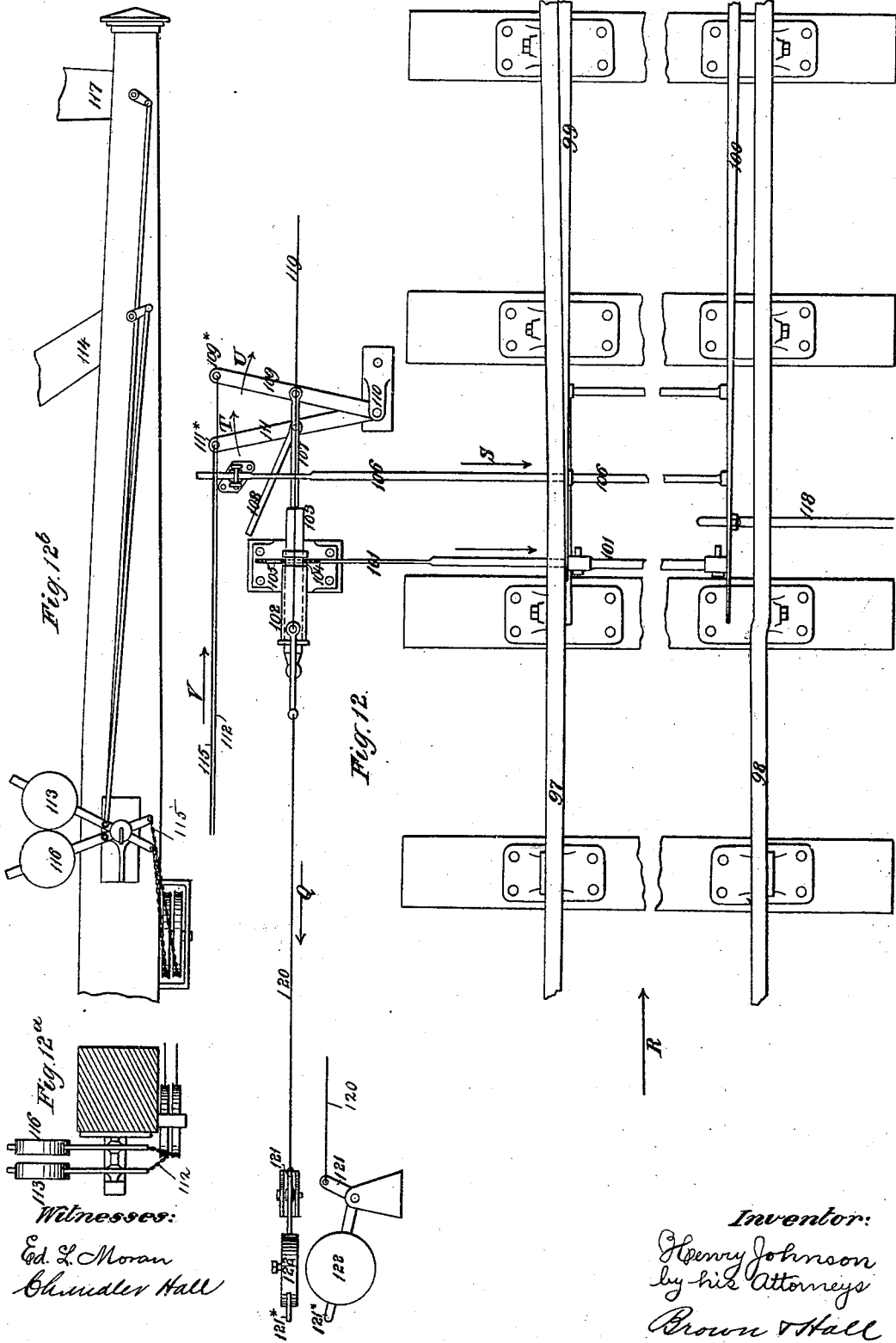

Witnesses:
 Ed. L. Moran
 Chandler Hall

Inventor:
 Henry Johnson
 by his Attorneys
 Brown & Hall

UNITED STATES PATENT OFFICE.

HENRY JOHNSON, OF FLIXTON, COUNTY OF LANCASTER, ENGLAND.

APPARATUS FOR OPERATING RAILWAY-SIGNALS.

SPECIFICATION forming part of Letters Patent No. 343,320, dated June 8, 1886.

Application filed November 13, 1883. Serial No. 111,653. (No model.)

To all whom it may concern:

Be it known that I, HENRY JOHNSON, of Flixton, in the county of Lancaster, England, engineer, have invented certain new and useful Improvements in Apparatus for Operating Railway-Signals, of which the following is a specification, reference being had to the accompanying drawings.

Railway points or switches are in some cases provided with apparatus by which they may be bolted or retained in either of two positions, thereby securing a "perfect road" in one direction or the other. A bolt or plunger is passed through one of two holes formed through a rod or bar attached to the points or switches, and commonly called a "stretcher-bar;" but if the switches do not lie completely over or against one or other of the "stock-rails" the aforesaid bolt or plunger cannot be passed through either of the holes formed through the said stretcher-bar, and the lever by which the aforesaid bolt or plunger is worked cannot be "pulled over." In most cases a bar is used in conjunction with the above-named bolt or plunger, such bar being mounted by the side of the stock-rail and connected to the aforesaid bolt or plunger, so as to prevent the withdrawal of such bolt or plunger during the passage of a train.

My invention consists in apparatus to be used in conjunction with the appliances previously described, whereby I am enabled to operate the signals with greater certainty and economy than heretofore, and whereby it becomes a condition that the switches must lie completely over on one side or the other before a signal can be lowered, and the signal lowered must be that corresponding with the position of the point or switch rails. The above object I accomplish by operating the signals by means of the lever used for actuating the facing-point lock through the medium of the plunger or bolt passing through the stretcher-bar, previously referred to as being attached to the point or switch rails, and provided with openings, through which the plunger or bolt passes, so as to lock the stretcher-bar in one of its two positions, and also to actuate the signals. Should the switches from any cause fail to move completely over from one side to the other, thereby not mak-

ing a "proper road" for either direction, no signal for the train to proceed can be given, as the movement of the plunger or bolt is stopped by the stretcher-bar, and communication with the signal is cut off; or, should the connections between the hand-lever and the points or switches fail, and such points or switches remain set for a direction contrary to that intended by a person operating the said switches, the actual position of the switches is truly indicated by the signals when the facing-point lock-lever is pulled over and the points are locked in that position, and until then both signals remain at "danger." If both point or switch connections and point-lock connections fail at one and the same time, "safety" is insured by the signals being kept at "danger," because connections with the bolt or plunger, and through that with the signals, is cut off by the failure. By making the connections of the hand-lever by which the facing-point lock-bar and the plunger or bolt are actuated first with the said bar, and thence with the plunger, and by making the plunger operate the signal, as hereinafter described, I insure not only the detection of any failure in the said connection affecting the action of the said bar, but any failure affecting the action of the plunger and the signals, thereby preventing accidents which might occur through connecting the said bar and plunger to the operating-lever through the medium of a T-crank, in the usual way. For, supposing the rod, which in that case connects the said bar to the T-crank, to become disconnected from the T-crank or the said bar, the plunger could be withdrawn, unlocking the switches, and the switches could be reversed during the passage of a train over them. In some cases trains pass in one direction only over the facing switches or points, and only one signal is then used. In such cases one hole only is formed through the stretcher bar or rod through which the plunger or bolt of the facing-point lock passes before the signal can be lowered. In such cases I use but one rod and connections to the signal, and this rod I do not cause to be moved laterally away from the path of the plunger or bolt, but make it to rest in a guide, so that its end is always opposite to the plunger or bolt and in a position to be operated, and is oper-

ated, by the movement of the plunger or bolt. Where two signals are used, and it is considered desirable to operate them by separate levers, I use two bars and two plungers or bolts, and in such cases they are exactly duplicates of the arrangements used for facing-points where trains are only signaled in one direction.

Having thus stated the nature of my invention, I will now proceed to more fully describe the same, reference being made to the accompanying drawings.

Figure 1 of the accompanying drawings is a plan of a facing-point lock and a set of points or switches illustrating my invention. Fig. 2 represents, on a larger scale than Fig. 1 a plan of the locking portions of the stretcher-bar, portions of the connecting-rods of the switch, and a portion of the mechanism through which the plunger operates the signal. Fig. 3 is a side view, partly in section, corresponding with Fig. 2. Fig. 4 is a plan partially in section, and Fig. 5 an elevation, of an ordinary signal-post, showing those parts only which are requisite to illustrate my invention. Fig. 6 is a plan view illustrating another method of carrying out my invention. Fig. 7 is a plan, and Fig. 8 a side elevation, of a signal-post corresponding with Fig. 6. Fig. 9 is a plan view illustrating another method of carrying out my invention. Fig. 10 is a plan, and Fig. 11 an elevation, of a signal-post corresponding with Fig. 9. Fig. 12 is a plan view illustrating another method of carrying out my invention in connection with siding-points. Fig. 12^a is a plan, and Fig. 12^b is an elevation, of a signal-post corresponding with Fig. 12. Fig. 13 is a plan view showing mechanism which may be substituted for the bell-crank levers shown in the other figures.

I will first describe my invention with reference to Figs. 1, 2, 3, 4, 5. At *a* and *b* are ordinary balance-levers, capable of being turned upon studs fixed to the signal-post *c*. Such levers *a b* are supported in the position shown by resting upon a projecting part, *d*^x, Fig. 5, of the bracket *d*, and thereby retain the signal-arms *e f*, and their respective "spectacles," (not shown) in a horizontal or, "danger" position until they are removed from that position by force exerted upon the wires *g h*, in the direction of the arrows A. At *i k* are the point or switch rails of an ordinary switch. (Shown in such position that a train passing along the rails *l m* in the direction of the arrow B will be directed into the right-hand road along the rails *l i*.) At *n o* are bars, each connected at one end to one of the switch-rails *i k*. The other ends of the bars *n o* overlap each other, and have two apertures formed in each of them, through which apertures the lock-bolt or plunger *p* may pass when both switch-rails *i k* are in the proper position for "making a road" either to the right hand or to the left hand in the direction of the arrow B. Should one of the point or switch rails *i k*

become detached by the breakage of connecting-rods 7 7^x, the apertures in the rods *n o*, which together constitute the stretcher-bar, will not coincide, and will thereby prevent the movement of the plunger *p*. This construction of the stretcher-bar of two pieces, *n o*, is no part of my invention, but is often used for the purpose of detecting the severance of the rods connecting one rail of the switch with the other. At *q* is the rod or wire connected at one end to the usual hand-lever by which the facing-point lock is operated and jointed at its other end to one end of a bell-crank lever, *r*, to the other end of which is jointed one end of a rod, *s*, the other end whereof is jointed to one end of a bell-crank lever *t*. To the remaining arm of the bell-crank lever *t* is jointed one end of a rod, *u*, the other end of which embraces a stud, *v*, attached to the "locking-bar" *w*. The stud *v* is also embraced by one end of a rod, *x*, the other end of which is jointed to one end of a lever, *y*, turning upon a center, *z*. To the end *y*^x of the lever *y* is jointed one end of a rod, *1*, of which the opposite end is jointed to the plunger or bolt *p*, sliding through an aperture formed in the bracket 2, through which also slide the bars *n o*, such apparatus constituting what is known as a "point-lock." At 3 is a bell-crank lever, and below it, as shown in the enlarged views, Figs. 2 and 3, is another bell-crank lever, 4. Jointed at one end to one arm, 3^x, of the bell-crank lever 3 is a rod, 5, and to one arm, 4^x, of the bell-crank lever 4 is jointed at one end a rod, 6, the other ends of the rods 5 6 passed through holes formed through a rod, 7, attached by its ends to the point or switch rails *i k*. To the ends 3^x 4^x of the bell-crank levers 3 4 are jointed the ends of rods 8 9. The other ends of the rods 8 9 are jointed to bell-crank levers 10 11, to which are connected the wires or rods *g h*, connected by chains passing around guide-pulleys to the balanced levers *a b*, respectively. The balance-lever *a* is connected by the usual rod, 12, to the semaphore-arm *e*, and the balance-lever *b* is connected by means of the rod 13 to the semaphore-arm *f*.

When it is desired to signal a train in the direction for which the points or switches are set as shown in the drawings, the person operating the signals will, by means of the usual hand-lever for working the point-lock, move the locking-bar *w* in the direction of the arrow C. Such movement will cause the plunger or bolt *p* to be moved in the direction which is indicated in Figs. 1, 2, and 3 by the arrow D, and the plunger will pass through the holes 14 in the bars *n o* and prevent the said rods from moving longitudinally, and will thus lock the points. The parts 2^a 2^b of the bracket 2 are slotted for the passage of the plunger, and form guides therefor, and the said parts have between them a transverse passage, 2^a, just wide enough to serve as a guide to the bars *n o*, which are prevented from rising by an anti-friction roller, 2^c, pivoted between the said

parts 2^a 2^b. The continued movement of the plunger *p* in the direction of the arrow D, after locking the points, as above described, causes it to abut against the end 6^x of the rod 6, and a still further movement of the plunger or bolt *p* will force the rod 6 in the direction of the arrow E, and by means of the bell-crank lever 4, rod 9, bell-crank lever 11, wire or rod *h*, lever *b*, and rod 13 will cause the semaphore-arm *f* to be lowered. After the train has passed clear of the switches or points the person operating such points or switches will reverse the position of the hand-lever, actuating the facing-point lock, and again bring the locking-bar *w* and lock-bolt or plunger *p* into the position shown in the drawings. Such movement will allow the weight upon the balance-lever *b* to return the signal *f* to "danger," and at the same time place the rod 6 in the position shown. I will now assume that a train is to be signaled along the branch line *m*^x *k*. The person operating the signals and switches or points, by means of the usual hand lever and rod, 15, and other connections, traverses the switches or points in the direction of the arrow F, until the point or switch rail *k* lies close against the stock-rail *l*. The traversing of the switch or point rails *i* *k* in the direction of the arrow F (see Figs. 1 and 2) will have caused the rods 5 6 to have been turned in the direction of the arrow G and brought the rod 5 into the position in line with the plunger *p*, which was previously occupied by the rod 6. The above-named person operating the points now traverses locking-bar *w* in the direction of the arrow C, by means of the facing-point lock-lever, thereby causing the plunger or lock-bolt *p* to move in the direction of the arrow D. Such plunger or lock-bolt *p* passing through the hole 16, formed in the rods *n* *o*, will lock the points, and a continued movement of the plunger or lock-bolt *p* will bring such plunger or lock-bolt *p* against the end of the rod 5, and a still further movement will thrust the rod 5 in the direction of the arrow E, thereby turning the bell-crank lever 3, and by means of the rod 8, bell-crank lever 10, wire or rod *g*, balance-lever *a*, and rod 12 will lower the signal *e*. As soon as the train has passed clear of the points, the person operating the signals may move the facing-point lock-lever and bring the locking-bar *w* and plunger or lock-bolt *p* into the position shown in the drawings, and thereby again places the signal to the "danger" position.

Figs. 6, 7, and 8 illustrate a method of carrying out my invention in conjunction with that arrangement for locking facing-points or switches, which is known as "Harrison's." In this arrangement the locking-bar 17 is connected by a rod, 18, oscillating shaft 19, and links 20 21 to wedges 22 23, which wedges 22 23 secure the point or switch rails 24 25 in either of their two positions. The point or switch rails 24 25 are secured to each other by tie-rods 26 27. At 28 29 are bell-crank levers capable of being turned upon centers 30 31,

respectively. To one end, 28^x, of the bell-crank lever 28 is jointed one end of a rod, 32, the other end of which passes through a hole formed in the tie-rod 26. From the end 28^x of the bell-crank lever 28 extends a wire, 33, which, after passing partially around the circumference of a guide-pulley, 34, is secured to one end of the balance-lever 35, connected to the semaphore-arm 36 of the signal-post 37. To one arm, 29^x, of the bell-crank lever 29 is jointed one end of a rod, 38, the other end of which is jointed to one arm whereof is connected by 47 to the balance-lever 40, connected to the semaphore-arm 41 of the signal-post 37. In the position of the parts as shown, the points or switches have been placed by the person operating them so as to direct a train passing in the direction of the arrow H onto the main-line rails 25 42. Placing the point or switch rails 24 25 in the position above described will have carried the bar 32 into the path of the wedge 23. When it is desired to signal a train along the rails 25 42, the person operating the points or switches and signals will, by means of the usual point-lock lever, move the rod 44 in the direction of the arrow J, such movement thrusting forward the wedges 22 23 in the directions of the arrows thereon, and the wedge 23, arriving against the rod 32, turns the bell-crank lever 28 in the direction of the arrow K, and by means of the wire 33, balance-lever 35, and usual rod lowers the semaphore-arm 36. As soon as the train has passed the points or switches, the wedges 22 23 are withdrawn, the weight upon the balance-lever 35 returns the arm 36 to "danger," and the rod 32 to its original position. When it is desired to direct a train along the branch lines 24 43, the point or switch rails 24 25 are drawn, by means of the usual hand-lever and rod or wire, 45, until the point or switch rail 24 lies close against the stock-rail 42. Such movement of the points or switches will bring the rod 46 within the path of the wedge 22. When it is desired to signal the train along the rails 24 43, the person operating the locking-bar 17 traverses it by the usual point-lock lever in the direction of the arrow L, such movement advancing the wedges 22 23 in the direction of the arrows thereon and bringing the wedge 22 against the end of the rod 46, and a continued movement of such wedge 22 will cause the bell-crank lever 29 to turn in the direction of the arrow M, and by means of the rod 38, bell-crank lever 39, wire 47, balance-lever 40, and usual rod, lower the semaphore-arm 41 of the signal-post 37. After the train has passed the points or switches the locking-bar 17 may be traversed in a direction opposite to that previously described, when the weight upon the balance-lever 40 will raise the semaphore-arm 41 to "danger," and return the rod 46 to its original position.

In the method of carrying my invention into effect, as shown by Figs. 9, 10, 11, I employ

two facing-point locks and two plungers, each of which is worked by separate hand-levers. One of such levers and facing-point locks being for the main line and the other lever and facing-point lock being for the branch line. At 48 49 are the stock or fixed rails, and at 50 51 are the point-rails. At 52 is the signal-post, provided with semaphore-arms 53 54, the arm 53 relating to the main line and the arm 54 to the branch. At 55 is a rod, one end of which is secured to a hand-lever, the other end, 55^x, being jointed to one arm of a bell-crank lever, 56. To the other arm, 56^x, of the bell-crank lever 56 is jointed one end of a rod, 57, the other end of which is jointed to one arm of the bell-crank lever 58. The remaining arm, 58^x, of the bell-crank lever 58 is jointed to one end of the rod 59, the other end of which is jointed to a stud, 60, projecting from the locking-bar 61, placed alongside the stock-rail 49. Mounted upon the stud 60 is one end of a rod, 62, the other end of which is jointed to one end of a lever, 63, turning upon a center 64. To the arm 63^x of the lever 63 is jointed a rod, 65, the other end of which is jointed to the lock-bolt or plunger 66. The rod 67 is connected at one end to a hand-lever and at the other end to one arm of a bell-crank lever, 68, the other arm, 68^x, of which is jointed to one end of a rod, 69, jointed at its other end to one end of a bell-crank lever, 70. The remaining arm, 70^x, of the bell-crank lever 70 is jointed to one end of a rod, 71, the other end of which embraces a stud, 72, projecting from the locking-bar 73; also embracing the stud 72 is one end of a rod, 74, the other end of which is jointed to one end of a lever, 75, turning upon a center, 76, such lever 75 being connected at its end 75^x by the rod 76 to the lock bolt or plunger 77. In the line of motion of the lock-bolt or plunger 66 is a rod, 78, one end of which passes through a fixed guide, 79. The other end of the rod 78 is jointed to one arm of a bell-crank lever, 80, the other arm, 80^x, of which is jointed to one end of a rod, 81, the other end of which is jointed to an arm of a bell-crank lever, 82, to the other end of which is attached a wire, 83, connected to the balance-lever 84, connected by the rod 85 to the semaphore-arm 53. In the line of motion of the lock-bolt or plunger 77 is a rod, 86, one end of which passes through a fixed guide, 87, the other end of the rod 86 being jointed to one arm of a bell-crank lever, 88, to the other arm, 88^x, of which is jointed one end of a rod, 89, which is connected at its other end to one arm of a bell-crank lever, 90. To the other arm of the bell-crank lever 90 is attached one end of a wire, 91, which at its opposite end is attached to the balance-lever 92, such balance-lever 92 being connected to the semaphore-arm 54 by means of a rod, 93. In the position of the parts as shown the point or switch rail 50 is close against the stock or fixed rail 48, so as to make a perfect road for the main-line rails 49 50.

To signal a train moving in the direction of

the arrow N for the main line, the person operating the points or switches has pulled over the point-lock lever, and thereby advanced the lock-bolt or plunger 66 in the direction of the arrow O. The lock-bolt or plunger 66 will during the above-described movement have been passed through the hole formed in the cross-bars 94 95, secured to the point or switch rails 50 51, respectively, and also have moved the rod 78 in the direction of the arrow O. Such movement of the rod 78, acting through the bell-crank lever 80, rod 81, bell-crank lever 82, wire 83, balance-lever 84, and rod 85, will have lowered the semaphore-arm 53 from "danger." I will now assume that the train previously referred to has passed over the points or switches, and that it is desired to direct a train onto the branch lines 48 51. The person operating the points or switches and signals pushes back the point-lock lever, the effect of which will be to withdraw the lock-bolt or plunger 66 from the rod 78, and also out of the hole in the bars 94 95. Such movement will allow the weight upon the balance-lever 84 to raise the semaphore-arm 53 to "danger," and will also permit the points or switches to be again traversed into the position shown, if desired. The point or switch rail 50 51 may then, by means of the point-lever and the rod 96, be traversed until the point or switch rail 51 is brought close against the stock-rail 49. The person aforesaid then pulls over the point-lock lever for the branch lines 48 51, so as to traverse the rod 67 in the direction of the arrow P. Such traversing of the rod 67, acting through the bell-crank lever 68, rod 69, bell-crank lever 70, rod 71, stud 72, rod 74, lever 75, and rod 76, will cause the lock-bolt or plunger 77 to be thrust in the direction of the arrow O, and to pass through the holes formed through the bars 94 95, thereby locking the points or switches in their correct position for directing the train along the branch line 48 51. A still further movement of the lock-bolt or plunger 77 will cause such lock-bolt or plunger to push the rod 86 and move it in the direction of the arrow O. Such movement, acting through the bell-crank lever 88, rod 89, bell-crank lever 90, rod or wire 91, lever 92, and rod 93, will lower the semaphore-arm 54 from its "danger" position. After the train has passed the points or switches the person operating such points or switches returns the point-lock lever to its normal position, and in doing so will withdraw the lock-bolt or plunger 77 out of contact with the rod 86 and out of the hole in the cross-bars 94 95. Such movement will allow the weight upon the balance-lever 92 to raise the semaphore-arm 54 to "danger" and return the rod 86 to its original position, and will also permit the points or switches to be again traversed into the position shown, if desired.

I will now describe the method of carrying my invention into effect in connection with siding-pointsshown by Figs. 12, 12^a, 12^b. At 97 98

are the stock-rails, and at 99 100 are the point or switch rails. Extending between the point or switch rails 99 100, and secured thereto, is a bar, 101, an extended portion of which passes through the socket 102 of the lock-bolt or plunger 103, and is provided with two holes, 104 105, through which the lock-bolt or plunger 103 may pass to lock the point or switch rails 99 100 against the stock-rails 97 98, respectively. Extending between the point or switch rails 99 100 is a bar, 106, an extended portion of which has two holes formed therein, through which pass rods 107 108. The rod 107 is jointed at one end to a lever, 109, which is jointed upon a fixed stud, 110. The rod 108 is jointed at one end to a lever, 111, one end of which is jointed upon the stud 110. To the end 109^x of the lever 109 is secured a wire or rod, 112, connected to one end of a balance-lever, 113, said balance-lever 113 being connected to the semaphore-arm 114. To the end 111^x of the lever 111 is connected one end of a wire, 115, connected to one end of a balance-lever, 116, connected to the semaphore-arm 117. To the point or switch rail 100 is secured one end of a bar, 118, the other end of which is connected to the usual hand-lever, by means of which the points or switches are operated. The lock bolt or plunger 103 is connected to the point-lock lever by which it is worked by means of a wire or rod, 119, and another wire, 120, is secured at one end to the lock-bolt or plunger 103, and at its other end to one end of a bell-crank lever, 121. The other end, 121^x, of the bell-crank lever 121 is provided with a weight, 122, which tends to draw the lock-bolt 103 in the direction of the arrow Q. It will be readily understood by persons conversant with apparatus for actuating point-locking apparatus that by substituting a rod for the wire 119, by which the lock-bolt or plunger 103 is connected to the lever by which it is actuated, the wire 120, lever 121, and weight 122 may be dispensed with. In the position of the parts as shown, a train passing in the direction of the arrow R will be directed along the siding-rails 98 99. Should it be desired to direct a train along the main-line rails 97 100, the person operating the signals and points or switches will put back the hand-lever by which the point-lock is actuated, and thereby allow the weight 122 to withdraw the lock-bolt or plunger 103 from the rod 107. The weight upon the balance-lever 113 will then descend and raise the semaphore 114 to "danger." A further movement of the lock-bolt or plunger 103 in the direction of the arrow Q will draw it clear of the hole 104 in the rod 101. The hand-lever by which the points or switches are traversed may then be operated, and the point or switch rail 99 withdrawn from the stock-rail 97, and the point or switch rail 100 forced into close contact with the rail 98, so as to make a perfect road to the main-line rails 97 100. The aforesaid movements of the points or switches will draw the bar 106 in the direction of the

arrow S, and turn the rod 108 into the line of motion of the lock-bolt or plunger 103. The person operating the lock-bolt or plunger 103 and the signal-arm 117 pulls over the hand-lever connected therewith, so as to draw the wire 119 in a direction opposite to that of the arrow Q. Such movement will pass the lock-bolt or plunger 103 through the hole 105 in the rod 101, thereby locking the point or switch rails 99 100, so as to secure a perfect road along the main-line rails 97 100. A further motion of the lock-bolt or plunger 103 will cause such lock-bolt or plunger 103 to arrive against the end of the rod 108, and a still further movement of the said lock-bolt or plunger 103 will push the rod 108, so as to turn the lever 111 in the direction of the arrow T, and thereby through the wire 115 and lever 116, will lower the semaphore-arm 117 from its "danger" position. Should it then be desired to direct a train along the siding-rails 98 99, the person operating the points or switches will first put back the point-lock lever, so as to traverse the lock-bolt or plunger 103 in the direction of the arrow Q, thereby withdrawing such lock-bolt or plunger 103 out of contact with the bar or rod 108, and the weight upon the balance-lever 116 will then raise the semaphore-arm 117 to the "danger" position, and a further movement of the lock-bolt or plunger 103 will move such lock-bolt or plunger clear of the bar 101. The person aforesaid may now move the hand-lever working the points or switches so as to traverse the point or switch rails 99 100, until the point or switch rail 99 is close against the stock-rail 97, so as to make a perfect road for the siding-rails 98 99. The point or switch rails 99 100 while being traversed will carry with them the bar 106 and turn the rod 107, so as to bring it into the line of motion of the lock-bolt or plunger 103. The person aforesaid now pulls over the point-lock lever so as to traverse the lock-bolt or plunger 103 in a direction opposite to that of the arrow Q, and pass it through the hole 104 in the bar 101, thereby locking the point or switch rails 99 100 in a position for making a perfect road along the rails 98 99. A further movement of the lock-bolt or plunger 103 will bring such lock-bolt or plunger 103 against the rod 107, and a still further movement of the said lock-bolt or plunger 103 will cause the lever 109 to be turned in the direction of the arrow U, and draw the wire 112 in the direction of the arrow V, so as to lower the semaphore-arm 114 from "danger."

Fig. 13 shows an arrangement which may be used in some cases, instead of some of the bell-crank levers previously referred to. At 123 124 are the rods or bars against which the lock-bolt or plunger 125 arrives in order to lower the signal. One end of each of these rods 123 I joint by means of a pin to the pulley 126, and to the pulley 127 I joint by means of a pin the rod 124. I secure one end of the wire 128, by which the semaphore-signal arm

belonging to the rails 129 130 is actuated, to the circumference of the pulley 126, and I secure one end of the wire 131, by which the signal having reference to the rails 132 133 is actuated, to the circumference of the pulley 127. When either of the pulleys 126 127 is rotated in the direction of the arrows thereon, the wires attached thereto will be wound partially around the circumference thereof, thereby transmitting motion from the lock-bolt or plunger 125 to the signal for the main or branch line, as the case may be. The wires from the pulleys 126 127 may be passed partially around guide-pulleys 134 135, to be directed in any desired direction.

By the hereinbefore-described invention it will be seen that by the employment of the lock-bolt to act upon apparatus for operating the signals, after such lock-bolt has secured the point-rails in position for making a perfect road, either for the branch or main line, it will be impossible for the person operating such signals to operate any signal other than that corresponding to the position in which the point-rails above named have been locked by the lock-bolt.

In all the examples of the invention represented the facing-point lock-bar is a part of the connection for operating the locking-plunger, which locks the switch-rails, and hence it is absolutely impossible to unlock the switches during the passage of a train over them.

I claim—

1. The combination, with a switch, a per-

forated bar connected with the same, and a locking-bolt for locking the switch by passing through the said bar, of a signal and levers and connections for operating the same, and movable pieces connected with the said levers and with the switch, to be presented to and withdrawn from the said plunger by the movements of the switch, for the purpose of producing the action of the signal by the said plunger after the latter has locked the switch, substantially as herein described.

2. The combination of a switch, a signal, a facing-point lock-bar, a plunger which both locks the switch and moves the signal, and means, substantially as herein described, for operating the said bar and plunger, whereby the said bar is made a part of the connections for operating the signal, substantially as and for the purpose herein set forth.

3. The combination, with a switch and a locking-plunger for locking the same, a facing-point lock-bar, and a signal, of a movable piece connected with the signal and with the switch, to be presented to and withdrawn from the locking-plunger, for the purpose of operating the signal by the said plunger, substantially as herein described.

HENRY JOHNSON.

Witnesses:

ARTHUR C. HALL,

9 Mann St., Manchester, England.

WM. JONES,

Manchester, England.