

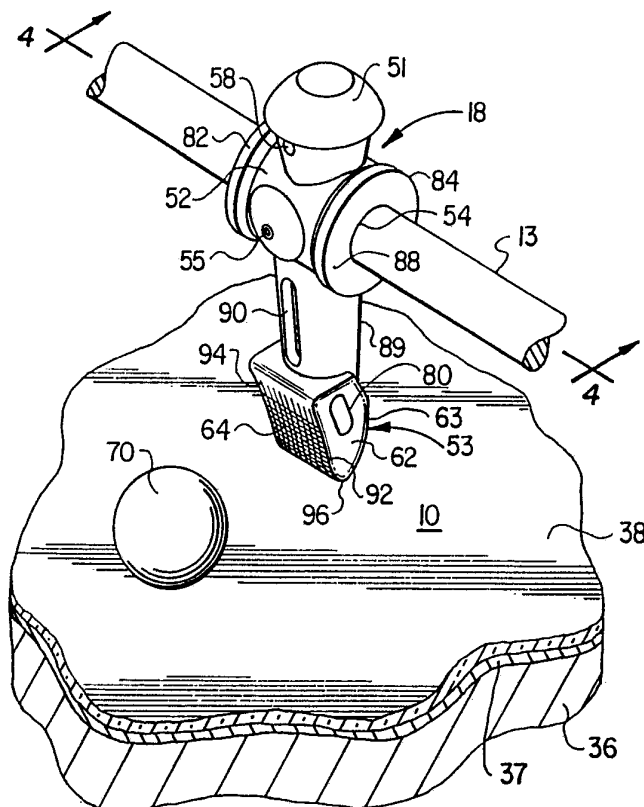


## INTERNATIONAL APPLICATION PUBLISHED UNDER THE PATENT COOPERATION TREATY (PCT)

<p>(51) International Patent Classification <sup>5</sup> : <b>A63F 7/06</b></p>	<p><b>A1</b></p>	<p>(11) International Publication Number: <b>WO 92/10253</b> (43) International Publication Date: 25 June 1992 (25.06.92)</p>
<p>(21) International Application Number: PCT/US91/09202 (22) International Filing Date: 10 December 1991 (10.12.91) (30) Priority data: 626,023 12 December 1990 (12.12.90) US (71)(72) Applicant and Inventor: McCLOUD, Calvin, Edward [US/US]; 4949 Rendon Road, Forth Worth, TX 76140 (US). (74) Agents: MOORE, Stanley, R. et al.; Johnson &amp; Gibbs, 100 Founders Square, 900 Jackson Street, Dallas, TX 75202-4499 (US). (81) Designated States: AT (European patent), BE (European patent), CH (European patent), DE (European patent), DK (European patent), ES (European patent), FR (European patent), GB (European patent), GR (European patent), IT (European patent), LU (European patent), MC (European patent), NL (European patent), SE (European patent).</p>		<p><b>Published</b> <i>With international search report. Before the expiration of the time limit for amending the claims and to be republished in the event of the receipt of amendments.</i></p>

**(54) Title: SOCCER PLAYING FIGURE AND METHOD OF MANUFACTURE****(57) Abstract**

An integrally molded table soccer playing figure (18) has an elongated body with a head (51) and foot portion (53) disposed at its opposite ends. A cylindrical passage (54) axially extends laterally through an upper portion of the body and is adapted to coaxially receive a longitudinal portion of an actuating rod (13) that is used to translate and rotate the playing figure. The body passage is diametrically sized to create a press-fit between the body portion and the rod portion therein, and the body is mechanically locked to the rod by a small roll pin (55). Washer portions (82, 84) are provided on opposite lateral sides of the body for shock absorption. A molding passage (80) in the foot portion and elongated recesses (90) in the opposite front and rear sides of the body serve to eliminate undesirable molding distortion. Contoured surfaces (63, 64) on the rear and front foot portions enhance the ball handling characteristics.



**FOR THE PURPOSES OF INFORMATION ONLY**

Codes used to identify States party to the PCT on the front pages of pamphlets publishing international applications under the PCT.

AT	Austria	ES	Spain	MG	Madagascar
AU	Australia	FI	Finland	ML	Mali
BB	Barbados	FR	France	MN	Mongolia
BE	Belgium	GA	Gabon	MR	Mauritania
BF	Burkina Faso	GB	United Kingdom	MW	Malawi
BG	Bulgaria	GN	Guinea	NL	Netherlands
BJ	Benin	GR	Greece	NO	Norway
BR	Brazil	HU	Hungary	PL	Poland
CA	Canada	IT	Italy	RO	Romania
CF	Central African Republic	JP	Japan	SD	Sudan
CG	Congo	KP	Democratic People's Republic of Korea	SE	Sweden
CH	Switzerland	KR	Republic of Korea	SN	Senegal
CI	Côte d'Ivoire	LI	Liechtenstein	SU <sup>+</sup>	Soviet Union
CM	Cameroon	LK	Sri Lanka	TD	Chad
CS	Czechoslovakia	LU	Luxembourg	TG	Togo
DE*	Germany	MC	Monaco	US	United States of America
DK	Denmark				

+ Any designation of "SU" has effect in the Russian Federation. It is not yet known whether any such designation has effect in other States of the former Soviet Union.

Soccer Playing Figure and Method of Manufacture.

BACKGROUND OF THE INVENTION

Field of the Invention

5           The invention relates to playing figures for use in table soccer or fussball game structures and, more particularly, to an improved playing figure construction.

History of the Prior Art

10           The game of table soccer, also known as fussball, has developed into a very popular pastime in recent years. Players of the game have likewise advanced in the skill necessary for competitive play. These developments have led to a myriad of improvements in the game table structure. One such improvement is shown in U.S. patent  
15 no. 3,926,432 issued December 16, 1975 to Robert L. Furr and Robert I. Hayes, Jr. As set forth therein, both the game table surface and the playing figures themselves have been designed for better ball control and player enjoyment. These aspects are critical to efficient ball  
20 control and player enthusiasm.

          Fussball game tables typically include a rectangular, box-like playing table structure supported on a plurality of legs at about waist height of a player. A plurality of axially slidable and rotatable actuating  
25 rods are mounted to extend transversely of the playing area. The actuating rods mount a plurality of playing figures which are arranged above the playing surface of the table in a preselected formation. A ball is placed

-2-

on the playing surface and propelled by sharply rotating the actuating rods so that a foot of a playing figure strikes the ball and propels it along the playing surface toward one of the two goals located in opposite end walls of the table structure.

5 In playing the game of table soccer, skilled players repeatedly manipulate the playing ball back and forth between adjacent ones of their playing figures to set up a clear path between the ball and their opponent's goal opening. Such manipulation includes passing the ball from one playing figure to another. A pass is effected through propelling the ball to one figure by striking it with the foot portion of a different figure. Another technique often used by players is that of manipulating a ball transversely with the rear foot portion of a figure and then suddenly circling the ball and shooting with the front of the foot portion. A ball passed from one figure to another is best caught with a receiving figure by first rotating the associated actuating rod to raise the foot portion to trap the ball between the foot portion and the playing surface of the table.

15 The front and rear surfaces of the foot portion of prior art playing figures greatly facilitated gripping a ball between the foot and the playing field surface. Likewise, in striking the ball, the relative positioning between the ball and playing figure determines the lift or spin imparted to the ball. This effect is due to the "varying" point of engagement of the ball resulting from its radial distance from the actuation rod. Such geometric considerations are integral in the ultimate functioning of fussball structures.

25 Problems associated with the manufacture and use of fussball playing figures include functional aspects such as ball control and effective shooting, as well as structural aspects related to the design of the playing figure, its mass distribution, structural strength and mounting features thereof.

-3-

Structurally, a fussball playing figure must withstand a wide range of forces which are imparted both rotationally and axially thereto. The force that some players use in the game of fussball is considerable and a fussball playing figure can be broken, and/or the playing rod bent, through inherent structural weakness if the playing figure is not properly designed.

The aforementioned problems include the interconnection between the playing figure and the actuating rod. In many instances, the playing figure is sized to be easily received upon the actuating rod and bolted thereto. The bolting configuration requires that an aperture be formed through the playing figure and through the rod through which a threaded member can be received. The stresses generated by the threaded member can induce fatigue failure to the rod, the weakness resulting therefrom contributing to failure of the rod during an intense play.

Likewise, the playing figure itself must be fabricated to withstand enormous rotational as well as axial forces. The sides of the playing figure are generally formed to receive a fiber washer, which washer serves to engage the side bumper of the fussball playing area, to absorb shock therefrom, when the playing figure is an end figure in the spaced series of figures typically secured to an actuating rod. If a suitable washer is not provided, the stress between the playing figure and the bumper can be considerable and may not be properly diffused.

Another structural aspect of the playing figure is the foot portion itself. A variety of playing surface configurations have been incorporated into the foot region but many of these relate primarily to the functional aspect of the playing figure such as ball control and effective "shooting". For example, U. S. patent no. 4,046,378 addresses one aspect of ball control

utilizing a pebbled striking surface on the playing figure foot.

5 The front surface of the playing figure set forth in this patent is pebbled over with its entire surface and lies in a plane angled rearwardly with respect to the longitudinal axis of the figure. The rear foot surface is also pebbled over most of its entire surface and lies in a plane angled forwardly with respect to the longitudinal axis of the figure except for an unpebbled control corner extending horizontally along the lower rear edge of the foot in a plane parallel to both the vertical and horizontal axis of the figure. The control corner increases the firmness with which a playing ball may be trapped between the playing foot and the playing surface.

10 15 The fabrication of the foot portion with such intricate features requires close fabrication control and tolerances. The sheer size of the playing foot and the thickness thereof requires that care be given to the manner in which material is molded into the playing figure itself. The necessary thickness of the foot can result in surface irregularities due to the thermal coefficients of expansion of the material and/or unplanned voids formed therein during the fabrication process.

20 25 30 35 With bubbles or other undesirable cavities formed underneath the playing foot surface, or with uncontrolled expansion or contraction of the material during molding and/or cooling, surface irregularities can occur which reduce the flatness of the surface configuration. When there is not appropriate flatness, the effectiveness of the surface for shooting the playing ball is jeopardized. Moreover, the surface must be rigidly associated with the upper body portion of the playing figure and concomitantly with the actuating rod.

The same constructional aspects are present in the fabrication of the playing figure with regard to the

-5-

depending portion connecting to the foot. Axial tolerances must be maintained without serious deformation during the cooling process. These and other structural and functional features must be considered in the proper fabrication and use of a fussball playing figure.

As mentioned above, a variety of playing surface configurations have heretofore been incorporated into the foot portions of conventional table soccer playing figures to enhance one or more of their ball handling capabilities such as shooting, trapping and passing. The result of this nonstandardization of foot configuration has been that skilled players using playing figures having a given foot configuration tend to develop a certain playing "style" which takes advantage of the special ball-handling capabilities of that particular foot configuration.

However, when these players switch to table soccer games whose playing figures have different foot portion configurations the players often find that the different foot configuration, while possibly having advantages of its own, does not permit them to carry out all of their previously learned ball-handling maneuvers as well or in the same manner as with the previous foot configuration. This often necessitates undesirable changes in the player's shot repertoire and overall playing style. It would thus be desirable to provide a foot portion configuration which could accommodate a wider variety of playing styles and ball-handling techniques.

It would be an advantage to overcome the problems of the prior art by providing a fussball playing figure having the requisite structural strength, balance and functional features for maximum reliability while affording the user the ultimate in versatility. The present invention overcomes the problems of the prior art by providing a fussball playing figure constructed with a number of features facilitating reliability and improved functional aspects.

For example, the playing figure is constructed with a central aperture formed through the upper body portion thereof adapted for receiving the actuating rod, the aperture being sized for a press fit interengagement with the actuating rod and having a relatively small aperture formed orthogonally therethrough adapted for receipt of a roll pin therein. In this manner, the actuating rod contains an aperture of a smaller diameter and adapted to receive the roll pin in a mounting configuration providing increased strength relative to conventional threaded fastener techniques.

The playing figure is also constructed with a foot region having a predefined aperture formed laterally therethrough of a size and configuration adapted for reducing the inherent problems of material mass and surface area deformation often resulting therefrom. The foot is also connected to the upper body region by a leg portion constructed in generally I-beam configuration affording increased strength and reduced mass for structural rigidity between the foot and the upper body.

The upper body is also fabricated with sidewall portions integrally formed therein and configured in the shape of the fiber washer conventionally affixed thereto. In this manner, a single structure affords the functional features necessary for direct mounting upon the actuating rod without the requirement that additional fiber washers be utilized or threaded fastener members that can result in degradation in the actuating rod itself.

The playing figure foot portion is additionally provided with a specially designed exterior surface configuration which easily accommodates a wide variety of different playing styles and ball-handling techniques which may have been learned and developed using playing figures with markedly different foot portion configurations.

SUMMARY OF THE INVENTION

In carrying out principles of the present invention, in accordance with a preferred embodiment thereof, a structurally and operationally improved table soccer game playing figure is provided. The playing figure is of an integrally molded construction and comprises an elongated body having opposite front and rear sides, opposite lateral sides facing perpendicularly to the front and rear sides, a head portion disposed on the top end of the body, and a foot portion disposed on the bottom end of the body.

A cylindrical passage axially extends laterally through an upper end portion of the body and is adapted for coaxial insertion therethrough of an elongated actuating rod to position a predetermined longitudinal portion of the rod within the passage, the rod portion having a connection opening extending transversely therethrough. A diametrically opposed pair of connector member openings are formed through the front and rear sides of the upper body end portion and are outwardly alignable with the rod portion connection opening.

According to a feature of the present invention, the diameter of the cylindrical body passage is made smaller than the outer rod diameter to an extent such that a press-fit engagement is created between the inner side surface of the passage and outer side surface of the rod portion upon entry of the rod portion into the passage. This press-fit engagement strongly inhibits relative axial and rotational movement between the upper body end portion and the rod portion received therein by creating an outwardly directed contact force, and a resultant static frictional force, which are essentially uniformly distributed around the inner side surface periphery of the body passage.

The releasable anchoring of the playing figure to the actuating rod is completed by longitudinally pressing a relatively small diameter roll pin into the aligned

-8-

transverse connection openings in the upper body end portion and the longitudinal rod portion press-fitted therein. The inserted roll pin serves to mechanically block relative rotational and translational movement between the body portion and rod portion without materially disrupting the essential uniformity of the playing figure/actuating rod connection force distribution.

This unique combination of the uniform press-fit engagement and the roll pin which does not exert appreciable transverse connection forces on the upper body portion essentially eliminates the undesirable connection stress concentrations, on both the playing figure and the actuating rod, which typically arise when the playing figure is conventionally tightened against the rod using a transverse connecting bolt. Accordingly, the anchored playing figure is better able to withstand lateral impact forces arising when the figure is on one end of the typical series of figures secured to an actuating rod. Moreover, the press-fit/roll pin combination provides more protection for the actuating rod by virtue of the lateral resiliency of the roll pin coupled with the aforementioned uniformity of the press-fit.

According to another aspect of the present invention, the playing figure is further protected from lateral impact damage by configuring the opposite lateral sides of its upper body end portion in the shape of radially enlarged washers which coaxially circumscribe the body passage and project outwardly beyond the opposite lateral sides of the playing figure head portion. The outer side surfaces of these integral washer portions of the body form expanded area side stops for the playing figure which function to receive and protectively diffuse side impact loads thereon, from a table side wall, when the figure is at either end of the spaced playing figure array on the actuating rod. This

-9-

advantageously eliminates the necessity of utilizing separate fiber washers to cushion side impact loads, and substantially strengthens the playing figure.

5 The foot portion of the playing figure is critical to the playing accuracy of the figure and has precisely contoured front and rear ball-engaging surfaces extending between essentially flat opposite lateral side surfaces of the foot portion. According to another feature of the present invention, a relatively large molding opening is  
10 formed in the foot portion and extends between these opposite lateral side surfaces. The molding opening functions to essentially prevent distortion of the precise contours of the front and rear foot portion side surfaces, and the formation of undesirable voids within  
15 the foot portion, during the molding of the playing figure. Additionally, to preserve the precise longitudinal linearity of the elongated playing figure during its molding, elongated, relatively deep surface depressions are formed on the front and rear sides of the  
20 body and longitudinally extend from adjacent its upper end portion to adjacent its foot portion.

In a preferred embodiment of the present invention, the critical foot portion of the playing figure is preferably provided with a specially designed exterior  
25 surface contour that substantially improves the ball-handling capabilities of the foot portion while at the same time significantly increasing the adaptability of the foot portion to a wide variety of playing "styles" previously learned and developed by players using playing  
30 figures with foot portions of markedly different configurations.

According to this feature of the present invention, the edges of the foot portion, at the junctures between the lateral sides of the foot portion and its front and  
35 rear side surfaces, do not form sharp corners as is typical in conventionally configured playing figure foot portions. Instead, these edges are radiused to provide

-10-

two primary advantages. First, the radiused foot portion edges do not tend to gouge the game ball when forcibly brought into contact therewith. Second, the radiused edges provide for better ball control when the ball is being contacted and propelled using an edge portion of the foot. Since sharp foot portion edges are not present, the exact positioning of the foot portion edge on the ball is not nearly as critical, and a greater margin for error in edge portion placement on the ball is advantageously provided.

Upper sections of the front and rear side surfaces of the foot portion are generally planar, while the lower sections of these surface are curved and join at their bottom ends to form a rounded lower end of the foot portion. The upper section of the rear side surface, and these curved lower front and rear side surface sections are pebbled to enhance their ball gripping capabilities. The generally planar upper section of the front side surface is not pebbled, but is provided with a spaced series of vertically extending surface ridges thereon.

The pebbled upper section of the rear side surface facilitates the trapping of the game ball for lateral passing purposes and other lateral ball maneuvers, while the curved and pebbled lower sections of the front and rear side surfaces of the foot portion facilitates the trapping of the ball in preparation for a subsequently executed forwardly or rearwardly directed "pin" shot. The vertically ribbed but unpebbled upper section of the front side surface enhances its forward ball shooting accuracy, but advantageously prevents such surface section from trapping the game ball between the foot portion and the playing surface.

BRIEF DESCRIPTION OF THE DRAWINGS

For a more complete understanding of the present invention and for further objects and advantages thereof, reference may now be had to the following description taken in conjunction with the accompanying drawings in which:

FIG. 1 is a perspective view of a fussball playing figure constructed in accordance with principles of the present invention and positioned upon an actuation rod above a playing surface;

FIG. 2 is an enlarged rear elevational view of the fussball playing figure of FIG. 1;

FIG. 3 is a front elevational view of the fussball playing figure of FIG. 1;

FIG. 4 is an enlarged scale cross-sectional view, partially in elevation, taken through the fussball playing figure and associated actuating rod along line 4-4 of FIG. 1; and

FIG. 5 is an enlarged scale lateral side elevational view of the FIG. 1 playing figure with a foot portion thereof operatively engaging the ball shown in FIG. 1.

DETAILED DESCRIPTION

As disclosed more fully in U.S. patent no. 3,926,432, incorporated herein by reference, a fussball game table includes a playing surface 10 shown in fragmentary perspective in FIG. 1, vertically extending end and sidewalls (not shown herein) and a plurality of actuating rods 13, rotatably mounted and axially slidable in opposite sidewalls. The actuating rods 13 are rotatably and slidably supported in a plurality of pairs of bearings (not shown) which are spaced along and in axial alignment with clearance apertures passing through the opposed longitudinal sidewalls.

Each actuating rod 13 slidably mounts one or more game figures 18. Soft, shock absorbing, cylindrical rubber bushings are rigidly mounted to each of the actuating rods 13 and are located outside the outermost

-12-

game figures 18 on each rod 13. The rubber bushings serve as bumpers to prevent the rod mounted game figures 18 from striking too hard against the inner sides of the wall, even during vigorous playing as the actuating rods 13 are quickly shifted axially to move the figures carried thereby relative to the playing surface 10.

Still referring to FIG. 1, there is shown a typical cutaway, perspective view of the playing surface of the table with sides and ends removed. While the particular pebbled configuration of the upper playing surface described herein is certainly unnecessary to practice the present invention, it is referenced herein for illustrating the aspect of ball control. This surface has been previously disclosed and claimed in a fussball table in U.S. patent no, 3,926,432. In FIG. 1, it can be seen how a wooden underlayer 36 supports a paper sheet 37 having a soccer field configuration printed thereon. The sheet 37 may be covered by a layer of glass 38. A ball 70 is representatively shown adjacent the foot portion 53 of the game figure 18.

Referring now to FIGS. 2 and 3, the playing figure 18 constructed in accordance with the present invention is of an integrally molded plastic construction and includes a head portion 51, a body portion 52, and the foot portion 53. The body portion 52 is perforated by a close tolerance transverse, circularly cross-sectioned opening 54 for receiving, in press fit engagement, the actuating rod 13 therethrough. Small circular openings 56, transverse to the opening 54, are formed in front and rear sides of the body portion 52 to receive a roll pin 55 which also passes through a pair of aligned apertures 56<sub>a</sub> in the actuating rod 13 (FIG. 4).

The foot portion 53 of the playing figure 18 is of extreme significance in that it is the means by which the ball 70 is manipulated and propelled toward an opponent's goal opening. The opposite lateral side surfaces 62 of the foot portion 53 are preferably smooth, flat and lie

-13-

in generally vertical planes to facilitate lateral passing of the ball from one playing figure to another figure on the same rod by merely tapping the ball. The front and rear surfaces 63 and 64, respectively, of the foot portion 53 have precisely configured contours to facilitate select ball engagement, as described in more detail below.

Referring now to FIG. 4, there is shown a frontal elevational cross-sectional view of the playing figure of FIG. 1 taken along line 4-4 thereof. Figure 18 is shown to be formed of solid molded plastic wherein aperture 54 comprises an elongate, lateral extension therethrough. The diameter D of aperture 54 is within .001" of the outside diameter (OD) of the rod 13 whereby the press fit engagement therebetween is one which affords close interengagement between the playing figure 18 and the rod 13.

This close fit interengagement negates the need for a threaded fastening member such as the type used in the prior art. Instead, the single roll pin 55 is received within the apertures 56, 56 of the aligned rod 13 and playing figure 18. The presence of the expandable roll pin is to maintain the alignment between the respective pieces and provide mechanical blocking resistance to any relative movement between the figure 18 and rod 13. Because of the press fit interengagement however, between the rod 13 and the interior side surface of aperture 54, very minimal stress is applied to the roll pin of the magnitude that could cause fatigue failure within the actuation rod 13.

Still referring to FIG. 4, the foot portion 53 is constructed with a molding aperture 80 formed laterally therethrough between its opposite side surfaces 62, which aperture is sized and positioned to remove mass from the foot 53. The removal of mass in the molding process from the foot 53 eliminates much of the potential for deformation along the ball-engaging surface areas 63, 64

-14-

of the foot 53. The aperture 80 thus extends laterally through the foot 53 in generally parallel spaced relationship with the aperture 54 in the upper body region thereabove. As illustrated, the aperture 80 is cross-sectionally elongated in a direction parallel to the generally planar foot surface 64.

Another feature of the playing figure 18 is the presence of integrally formed washers 82 and 84 formed outwardly of the aperture 54. The washers 82 and 84 are sized to provide radially enlarged, flat annular abutment surfaces 86 and 88, spaced laterally outwardly of head portion 51, against which the playing figure 18 may engage the bumper of a fussball table. Since all playing figures are interchangeable, it is impossible to determine at the time of manufacture which playing figure will be positioned on a rod at the outermost position whereby it will engage the bumper of the fussball table during the axial movement of the control rod 13. The integrally molded wide surfaces 86, 88 afforded by washers 82 and 84 provide sufficient engagement surface area to significantly reduce point stresses on the bumper and to further cushion the actuation thereof, and permits any figure to be an end figure on the actuating rod 13.

Referring now to FIG. 5, there is shown a playing figure 18 in engagement with the ball 70. In FIG. 5 the playing figure 18 is shown in a position of rotation about the actuation rod 13. The ball 70 is shown to engage the foot portion 53 at a point 79. Point 79 is substantially above the center line of the ball 70 as drawn through center 83 thereof. Point 79 is on the rear foot surface 64 of the playing figure 18, which surface 64 is shown more clearly in FIG. 2 comprising an elongate roughened surface adapted for stopping the ball for purposes of positioning prior to shooting. In this position, the playing figure foot portion has in essence "trapped" the playing ball 70 and said ball may be slowly moved in position for spinning of the playing figure 18

-15-

about the actuation rod 13 for engagement by the front foot surface 63. The front foot surface 63 is shown most clearly in FIG. 3 to comprise a shortened area having the elongate flutings 90 formed therein adapted for enhancing lateral stability of the ball during the striking motion.

In operation, the playing figure 18 affords both the manufacturer and the user enhanced structural and functional properties. For the manufacturer, the design provides a playing figure having an integrally formed set of side washers 82 and 84 which provide uniform structural interengagement between the playing figure 18 and the bumper of the fussball table when engagement occurs from axial movement of the rod. This engagement of high force is further accommodated by the press fit interengagement of the actuation rod 13 within aperture 54 secured thereto by roll pin 55. The configuration is provided so that there is no normal or right angle force generated against the shaft 13 by a threaded member as prevalent in prior art configurations. This affords the user greater reliability and avails the user of the opportunity to apply appreciable forces to the rod and playing figure without degenerative effects therein.

As stated above, the presence of the molding aperture 80 formed in the foot 53 further eliminates manufacturing problems by providing an area of reduced mass, the surfaces of which may be formed in a relatively flat configuration in accordance with the original design and substantially unaffected by expansion and contraction as well as nonhomogeneous molding aspects that would otherwise possibly cause deformation and surface irregularities in the most critical area of the playing figure, that being the area in which the ball is contacted.

Finally, it is seen that the leg section 89 formed in an I-beam shape to provide the same advantages of reduced mass in the formation process to maintain the axial alignment of the foot 53 relative to the lateral

-16-

aperture 54, while still affording the requisite structural rigidity in leg portion 89. The I-beam shape of leg portion 89 is achieved by the formation of vertically elongated, relatively deep surface recesses 90 in its front and rear sides, the recesses 90 extending from adjacent the upper body portion 52 to adjacent the foot portion 53. Those individuals using the fussball structure of the present invention may be able to utilize many manifestations of ball control and force with a reliable configuration which was not available in prior art embodiments.

In a manner similar to that illustrated and described in U.S. patent 3,926,432 the playing figure head portion 51 (FIGS. 1 and 2) has disposed therein a small weight member 58, the purpose of which is to rotationally balance the overall playing figure 18 so that it exerts no appreciable torque on the actuating rod 13 about its axis. The previously mentioned formation in the body portion 89 and the foot portion 53 of the surface recesses 90 and the molding passage 80 not only provides the molding accuracy advantages discussed above, but also substantially reduces the overall weight of body portion 89 and foot portion 53 which are disposed below the actuating rod axis in the vertical playing figure orientation shown in FIGS. 2 and 3.

This weight reduction in the lower longitudinal portion of the playing figure correspondingly raises the playing figure center of gravity toward the rod axis. In turn, this permits the head portion 51 to be vertically shortened, thereby enhancing a player's field of vision over the playing figure 18 when it is upright as shown in FIGS. 2 and 3, and advantageously increasing the ball clearance between the playing surface and the head portion 51 when the playing figure is upside down.

In addition to its other attributes previously discussed herein, the playing figure foot portion 53 is provided with a specially designed exterior surface

-17-

contour which substantially improves its ball-handling capabilities while at the same time significantly increasing its adaptability to a wide variety of playing "styles" previously learned and developed by players using playing figures with foot portions of markedly different configurations.

According to one aspect of this improved surface contour the foot portion corner edges 92 and 94, formed at the junctures between lateral side surfaces 62 and the front and rear side surfaces of the foot portion, are radiused as best indicated in FIGS. 1 and 5. This corner edge radiusing essentially eliminates gouging of the game ball 70 when it is struck with an edge of the foot portion, and also provides for improved ball control when the ball is being contacted and propelled using a corner edge portion of the foot. Since sharp foot portion edges are not present, the exact positioning of the foot portion edge on the ball is considerably less critical, and a greater margin for error in edge portion placement on the ball is advantageously provided.

The overall front and rear side surface contours of the foot portion 53 are also specially configured in a manner which will now be described in conjunction with FIGS. 2, 3 and 5. As illustrated in these three figures, upper sections 63<sub>a</sub>, 64<sub>a</sub> of front and rear foot portion side surfaces 63, 64 are generally planar, with section 64<sub>a</sub> being pebbled, and section 63<sub>a</sub> being unpebbled, but vertically ribbed as at 90 (FIG. 3). Pebbled lower sections 63<sub>b</sub>, 64<sub>b</sub> of side surfaces 63, 64 are radiused, extend downwardly from the bottom ends of surface sections 63<sub>a</sub> and 64<sub>a</sub>, and join at their lower ends to form a rounded bottom end 96 of foot portion 53.

During play, the pebbled upper rear surface section 64<sub>a</sub> facilitates the trapping of game ball 70 (FIG. 5) for lateral passing purposes and other lateral ball maneuvers, while the curved and pebbled lower surface sections 63<sub>b</sub>, 64<sub>b</sub> facilitate the trapping of the ball,

-18-

with a lower part of foot portion 53, in preparation for a subsequently executed forwardly or rearwardly directed "pin" shot. The vertically ribbed but unpebbled upper front side surface section 63, provides enhanced forward ball shooting accuracy when this surface section is used, the ribs 90 inhibiting lateral shifting of the ball relative to the foot portion while at the same time essentially preventing undesirable trapping of the ball between surface section 63, and the playing surface.

It is thus believed that the operation and construction of the present invention will be apparent from the foregoing description. Although the method and apparatus shown or described has been characterized as being preferred it will be obvious that various changes and modifications may be made therein without departing from the spirit and scope of the invention as defined in the following claims.

-19-

What is claimed is:

1. Table soccer game apparatus comprising:

5 a playing figure having a body portion with a passage extending therethrough along an axis and adapted for coaxial insertion therethrough of an elongated actuation rod to position a predetermined longitudinal portion of the rod within said passage; and

10 connection means for releasably anchoring said body portion to said rod portion for rotation and axial translation therewith, said connection means including:

15 first means for creating between the interior side surface of said passage and the outer side surface of said rod portion a static frictional force essentially uniformly distributed around the interior side surface periphery of said passage and of sufficient strength to strongly inhibit relative rotational and translational movement between said body portion and said rod portion, and

20 second means for mechanically blocking relative rotational and translational movement between said body portion and said rod portion without materially disrupting the essentially uniform static frictional force distribution around said interior side surface periphery of said passage.

25 2. The table soccer game apparatus of Claim 1 wherein said first means include:

30 a lateral size differential between said passage and said rod portion which, in response to movement of said rod portion into said passage, creates a press-fit engagement between said body portion and said rod portion.

3. The table soccer game apparatus of Claim 2 wherein:

35 said rod portion has first opening means extending generally transversely therethrough, and

-20-

said second means include second opening means formed through said body portion and outwardly alignable with said first opening means, and a roll pin longitudinally insertable into the aligned first and second opening means.

4. The table soccer game apparatus of Claim 1 wherein:

said rod portion has first opening means extending generally transversely therethrough, and

10 said second means include second opening means formed through said body portion and outwardly alignable with said first opening means, and a roll pin longitudinally insertable into the aligned first and second opening means.

15 5. In a table soccer game playing figure of the type having a body portion with a passage extending therethrough along an axis and adapted for coaxial insertion therethrough of an elongated actuation rod to position a predetermined longitudinal portion of the rod  
20 in said passage, said rod portion having first opening means extending generally transversely therethrough; second opening means extending through said body portion and outwardly alignable with said first opening means; a connecting member extendable through the aligned first  
25 and second opening means and operative to mechanically block relative translational and rotational movement between said body portion and said rod portion; and means for creating and maintaining a strong static frictional force between portions of the interior side surface of  
30 said passage and the outer side surface of said rod portion, the improvement wherein said means for creating and maintaining are operative independently of said connecting member to create and maintain a strong static frictional force between said rod portion and  
35 substantially all of said interior side surface of said passage.

-21-

6. The improvement of Claim 5 wherein:

said means for creating and maintaining are operative to create a press-fit between said body portion and said rod portion in response to entry of said rod portion into said passage.

5

7. The improvement of Claim 5 wherein:

said connecting member is a roll pin.

8. An improved method of removably anchoring a playing figure to a table soccer game actuating rod for rotation and axial translation therewith, said playing figure having a body portion through which a passage extends along an axis, said passage being adapted to coaxially receive said rod and permit said playing figure to be moved axially along the rod to an operative position thereon, said improved method comprising the steps of:

10

15

laterally sizing said passage to automatically maintain in the operatively positioned playing figure a press-fit engagement between the interior side surface of said passage and the outer side surface of the rod portion within said passage, said press-fit engagement being operative to create:

20

a frictional force between said body portion and said rod portion of sufficient strength to strongly inhibit relative movement between said body portion and said rod portion, and

25

an outwardly directed connection force imposed on said body portion transversely to said axis and essentially uniformly distributed around the interior side surface periphery of said passage; and

30

extending connector means through said body portion and said rod portion,

said connector means being operative to further inhibit relative movement between said body portion and said rod portion without substantially altering the essentially uniform distribution of said connection force

35

-22-

around the interior side surface periphery of said passage.

9. The improved method of Claim 8 wherein:

5 said method further comprises the steps of forming first opening means generally transversely through said rod portion, and forming second opening means through said body portion, said second opening means being outwardly alignable with said first opening means, and  
10 said step of extending connector means through said body portion and said rod portion is performed by longitudinally pressing a roll pin into the aligned first and second opening means.

10. In a unitarily molded table soccer playing figure of the type mountable on an actuating rod, as one  
15 of a longitudinally spaced plurality of playing figures mounted thereon, and having an elongated body with head and foot portions at its opposite ends; a passage extending transversely through said body along an axis and adapted to coaxially receive a longitudinal portion  
20 of the rod fixedly securable to said body; and first and second opposite lateral side surface portions spaced apart along and circumscribing said axis, one of said first and second side surface portions being subjectable to a high, potentially damaging lateral playing force  
25 when said figure is an end figure in said longitudinally spaced plurality of playing figures, the improvement comprising:

30 first protective means, molded integrally with said one of said first and second lateral side surface portions, for receiving and protectively absorbing said lateral playing force, said first protective means including a generally washer-shaped portion through which the rod may be passed, said generally washer-shaped portion having an annular outer side surface which is  
35 perpendicular to said axis, positioned laterally

-23-

outwardly of said head portion, and radially enlarged relative to said one of said first and second lateral side surface portions which it shields from inwardly directed lateral impact force.

5           11. The improvement of Claim 10 further comprising:  
            second protective means, molded integrally with the  
            other of said first and second lateral side surface  
            portions, said second protective means being  
10           substantially identical in configuration and operation to  
            said first protective means, whereby said playing figure  
            may be utilized as either end figure in said  
            longitudinally spaced plurality of playing figures.

            12. An integrally molded table soccer game playing  
            figure comprising:  
15           a foot portion having opposite first and second  
            lateral side surfaces and opposite front and rear ball-  
            engaging surfaces having predetermined contours; and  
            molding passage means extending through said foot  
            portion from said first lateral side surface to said  
20           second lateral side surface, said molding passage means  
            being operative to substantially eliminate undesirable  
            distortion of said predetermined ball-engaging surface  
            contours, and the formation of undesirable molding voids  
            within said foot portion, during the molding of said  
25           playing figure.

            13. The playing figure of Claim 12 wherein:  
            one of said opposite front and rear ball-engaging  
            surfaces of said foot portion has a generally planar  
            section, and  
30           said molding passage means are cross-sectionally  
            elongated in a direction substantially parallel to said  
            generally planar section.

14. An integrally molded table soccer game playing figure comprising:

5 an elongated body having front and rear sides, opposite first and second lateral sides facing generally transversely to said front and rear sides, an upper end portion having top and bottom sides, and a lower end portion extending downwardly from said bottom side of said upper end portion of said body and having a bottom end;

10 a head portion positioned on and extending upwardly from said top side of said upper end portion of said body;

15 a foot portion positioned on and extending downwardly from said bottom end of said lower end portion of said body, said foot portion having opposite lateral side surfaces and opposite front and rear ball-engaging surfaces having predetermined contours;

20 a circularly cross-sectioned passage longitudinally extending, along an axis, through said upper end portion of said body between said first and second lateral sides thereof, said passage being adapted for coaxial insertion therethrough of an elongated actuating rod to position a predetermined longitudinal portion of the rod therein;

25 an opposed pair of connector member openings extending inwardly through said front and rear sides of said upper end portion of said body and communicating with said passage;

30 a molding passage formed in said foot portion and opening outwardly through its opposite lateral side surfaces, said molding passage being configured, and positioned on said foot portion, to substantially eliminate undesirable distortion of said predetermined ball-engaging surface contours, and the formation of undesirable molding voids within said foot portion, during the molding of said playing figure; and

35 a pair of tubular portions axially extending laterally outwardly from said first and second lateral

-25-

sides of said upper end portion of said body, with the interior side surfaces of said tubular portions defining axial extensions of said passage, each of said tubular portions having:

5 an inner end portion directly adjacent one of said lateral sides of said upper end portion of said body, and

10 a radially enlarged outer end portion having an essentially planar, annular outer side surface disposed perpendicularly to said axis and positioned laterally outwardly of said head portion.

15 15. The playing figure of Claim 14 wherein:  
said rod portion has an outer diameter, and  
said circularly cross-sectioned passage has a diameter sufficiently smaller than said rod portion outer diameter to create a press-fit engagement between the inner side surface of said passage and the outer side surface of said rod portion in response to axial movement of said rod portion into said passage.

20 16. The playing figure of Claim 14 wherein:  
one of said opposite front and rear ball-engaging surfaces of said foot portion has a generally planar section, and  
25 said molding passage is cross-sectionally elongated in a direction substantially parallel to said generally planar section.

30 17. The playing figure of Claim 14 further comprising:  
first and second vertically elongated, relatively deep surface recesses respectively formed in the opposite front and rear sides of said lower end portion of said body.

-26-

18. The playing figure of Claim 17 wherein:  
each of said elongated surface recesses  
longitudinally extends from adjacent said head portion to  
adjacent said foot portion.

5 19. A table soccer game playing figure comprising  
an elongated body having an upper end portion through  
which an actuating rod-receiving passage transversely  
extends, a lower end, and a foot portion secured to and  
extending downwardly from said lower end, said foot  
10 portion being manipulatable to operably engage a game  
ball rollingly supported on a playing surface above which  
the playing figure is movably carried by an actuating  
rod, said foot portion including:

a front side having a generally planar upper section  
15 and a curved lower section; and

a rear side having a generally planar upper section  
and a curved lower section which, with said lower section  
of said front side, forms a convexly curved lower end  
surface of said foot portion,

20 said upper section of said rear side, and said  
lower sections of said front and rear sides, having first  
surface roughening means formed thereon which function,  
when operatively engaged with the game ball, to  
facilitate the releasable trapping of the game ball  
25 between said foot portion and the playing surface,

said upper section of said front side having  
second surface roughening means formed thereon which  
function, when operatively engaged with the game ball, to  
enhance the forward ball shooting accuracy of said upper  
30 section of said front side but essentially preclude the  
trapping of the game ball between said upper section of  
said front side and the playing surface.

20. The table soccer game playing figure of Claim  
19 wherein:

-27-

said first surface roughening means provide said upper section of said rear side, and said lower sections of said front and rear sides, with generally pebbled exterior surface contours.

5           21. The table soccer game playing figure of Claim 19 wherein:

said second surface roughening means provide said upper section of said front side with a generally vertically ribbed exterior surface contour.

10           22. The table soccer game playing figure of Claim 19 wherein:

said foot portion further includes a pair of spaced apart lateral surfaces extending between said front and rear sides and defining therewith side edge corner portions of said foot portion which may be brought into playing contact with the game ball, and

15           said side edge corner portions are radiused to protect the game ball from damage therefrom and to provide a player of the game with an increased margin for positional error with respect to proper placement of said side edge corner portions against the game ball.

20           23. For use in conjunction with a table soccer game playing figure of the type having:

25           an elongated body extending along a longitudinal axis and having opposite front and rear sides, opposite lateral sides, an upper end portion, a lower end portion spaced downwardly apart from said upper end portion along said longitudinal axis, and a longitudinally intermediate portion extending along said longitudinal axis and interconnecting said upper and lower end portions,

30           a head portion secured to said upper body end portion and projecting upwardly therefrom, along said longitudinal axis, through a head portion height,

-28-

a foot portion secured to said lower body end portion and projecting downwardly therefrom along said longitudinal axis,

5 a passage extending through said upper body end portion, along a lateral axis transverse to said longitudinal axis, and adapted to coaxially receive a longitudinal portion of an actuating rod securable to said upper body end portion and operable to position the playing figure above a playing surface for rotation about  
10 said lateral axis between an upright position in which said longitudinal axis is perpendicular to the playing surface with said head portion disposed above said foot portion, and an inverted position in which said longitudinal axis is perpendicular to the playing surface  
15 with said head portion being disposed beneath said foot portion and upwardly separated from the playing surface by a clearance distance,

a method of operationally improving said playing figure, said method comprising the step of:

20 forming a relatively large opening laterally through said foot portion, the playing figure mass deleted by said opening permitting said head portion height to be reduced, without creating a longitudinal shift in said center of gravity, to thereby advantageously increase  
25 said head portion clearance distance when said playing figure is in said inverted position thereof, and to advantageously increase a player's field of vision over said playing figure when said playing figure is in said upright position thereof.

30 24. The method of claim 23 wherein:

said playing figure is of an integrally molded construction, and

said step of forming a relatively large opening is performed during the molding of said playing figure.

-29-

25. The method of Claim 23 further comprising the step of:

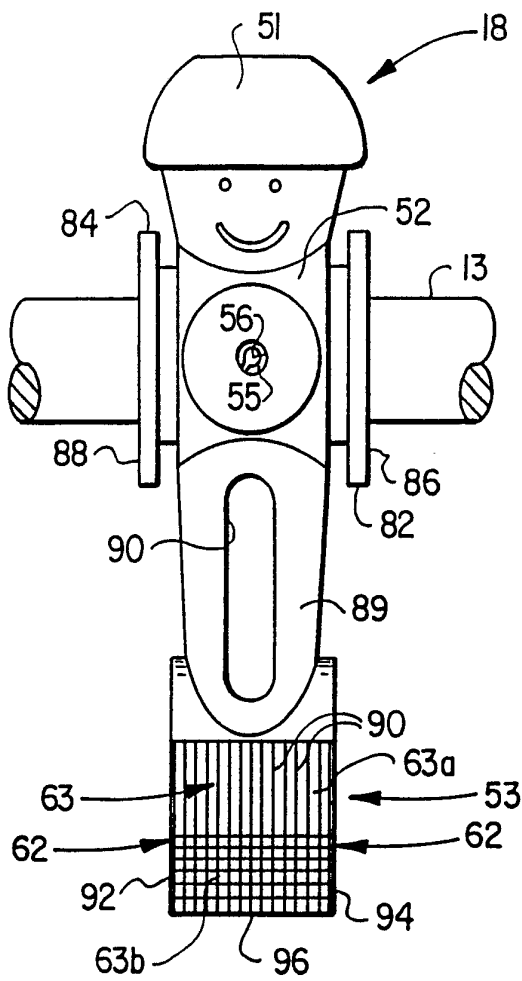
forming relatively deep surface depressions in said longitudinally intermediate body portion to thereby  
5 permit a further reduction in said head portion height without creating a longitudinal shift in said center of gravity.

26. The method of Claim 25 wherein:

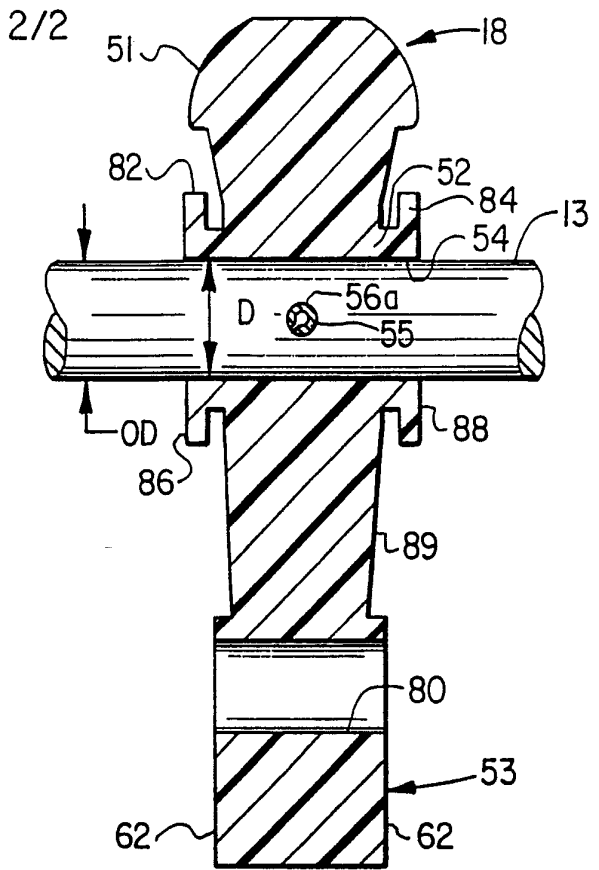
said playing figure is of an integrally molded  
10 construction, and

each of said forming steps is performed during the molding of said playing figure.

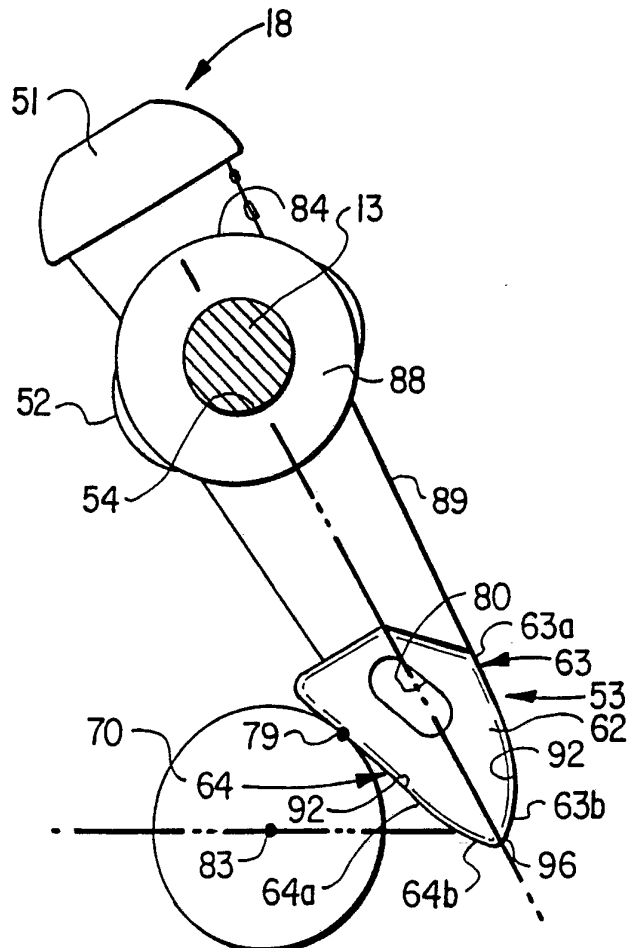




**FIG. 3**



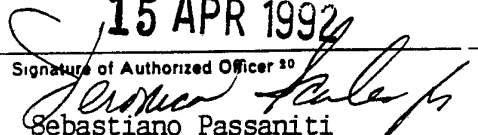
**FIG. 4**



**FIG. 5**

# INTERNATIONAL SEARCH REPORT

International Application No PCT/US91/09202

<b>I. CLASSIFICATION OF SUBJECT MATTER</b> (if several classification symbols apply, indicate all) <sup>3</sup>		
According to International Patent Classification (IPC) or to both National Classification and IPC		
IPC(5): A63F 7/06		
U.S. CL: 273/85D		
<b>II. FIELDS SEARCHED</b>		
Minimum Documentation Searched <sup>4</sup>		
Classification System <sup>1</sup>	Classification Symbols	
U.S.	273/85R, 85A, 85C, 85D, 85E, 85F, 119R, 129R, 129V, 129W	
Documentation Searched other than Minimum Documentation to the Extent that such Documents are Included in the Fields Searched <sup>5</sup>		
<b>III. DOCUMENTS CONSIDERED TO BE RELEVANT</b> <sup>14</sup>		
Category <sup>6</sup>	Citation of Document, <sup>16</sup> with indication, where appropriate, of the relevant passages <sup>17</sup>	Relevant to Claim No. <sup>14</sup>
X	US,A 4,138,110 (HENDRICKSON) 06 February 1979 See the entire document.	1-9
A	US,A 4,025,073 (FURR ET AL) 24 May 1977 See Figures 6A, and 7.	
A	FR,A 991,037 (ACHARD) 28 September 1951 See Figure 1.	
A	FR,A 985,312 (BERARD) 17 July 1951 See Figure 1.	
A	FR,A 1,034,971 (LEGUE') 10 August 1953 See Figures 2, and 3	
A	FR,A 980,203 (ZOSSO) 09 May 1951 See Figure 2.	
A	FR,A 834,474 (SWINNEN) 22 November 1938 See Figure 3.	
A	FR,A 746,550 (TRONCHET) 30 May 1933 See Figure 2.	
A	FR,A 1,359,795 (MAILLARD) 23 March 1964 See Figure 2.	
A	IT,A 518,959 (MIGNOLA ET AL) 10 March 1955 See Figure 2	
(CONT)		
<p><sup>15</sup> Special categories of cited documents:</p> <p>"A" document defining the general state of the art which is not considered to be of particular relevance</p> <p>"E" earlier document but published on or after the international filing date</p> <p>"L" document which may throw doubts on priority claim(s) or which is cited to establish the publication date of another citation or other special reason (as specified)</p> <p>"O" document referring to an oral disclosure, use, exhibition or other means</p> <p>"P" document published prior to the international filing date but later than the priority date claimed</p>		<p>"T" later document published after the international filing date or priority date and not in conflict with the application but cited to understand the principle or theory underlying the invention</p> <p>"X" document of particular relevance; the claimed invention cannot be considered novel or cannot be considered to involve an inventive step</p> <p>"Y" document of particular relevance; the claimed invention cannot be considered to involve an inventive step when the document is combined with one or more other such documents, such combination being obvious to a person skilled in the art.</p> <p>"&amp;" document member of the same patent family</p>
<b>IV. CERTIFICATION</b>		
Date of the Actual Completion of the International Search <sup>2</sup>	Date of Mailing of this International Search Report <sup>3</sup>	
17 March 1992	15 APR 1992	
International Searching Authority <sup>1</sup>	Signature of Authorized Officer <sup>20</sup>	
ISA/US	 Sebastiano Passaniti	

III. DOCUMENTS CONSIDERED TO BE RELEVANT (CONTINUED FROM THE SECOND SHEET)		
Category *	Citation of Document, <sup>16</sup> with indication, where appropriate, of the relevant passages <sup>17</sup>	Relevant to Claim No <sup>18</sup>
	(CONT).	
A	CH,A 466,774 (TOUSJEUX ET AL) 01 January 1969 See Figures 1(a) and 1(b).	
A	CH,A 356,393 (GLOOR) 09 September 1961 See Figures 1 and 2.	
Y	US,A 4,046,378 (FURR) 06 September 1977 See the entire document.	19-22
A	US,A D 208,480 (FRAITZCHER ET AL) 05 September 1967 See Figures 1-3.	
Y	US,A 3,920,244 (KAISER) 18 November 1975 See the entire document.	12-26
YE	US,A 5,071,137 (MCCLLOUD) 10 December 1991 See the entire document.	10 and 11
Y	US,A 3,653,661 (LEONHART) 04 April 1972 See the entire document.	10 and 11
Y	US,A 4,127,269 (REST) 28 November 1978 See the entire document.	10 and 11
A	FR,A 984,162 (BERARD) 03 July 1951 See Figure 1.	
A	FR,A 1,066,421 (SORET) 04 June 1954 See Figures 1 and 2.	
A	CH,A 390,764 (HALDIMANN) 08 August 1965 See Figures 1-3.	