

(19) World Intellectual Property  
Organization  
International Bureau



(43) International Publication Date  
15 January 2004 (15.01.2004)

PCT

(10) International Publication Number  
WO 2004/005764 A2

- (51) International Patent Classification<sup>7</sup>: **F16H 59/02**
- (21) International Application Number:  
PCT/GB2003/002850
- (22) International Filing Date: 3 July 2003 (03.07.2003)
- (25) Filing Language: English
- (26) Publication Language: English
- (30) Priority Data:  
0215472.2 4 July 2002 (04.07.2002) GB
- (71) Applicant (for all designated States except US): **EATON CORPORATION** [US/US]; Eaton Center, 1111 Superior Avenue, Cleveland, OH 44114-2584 (US).

(81) Designated States (*national*): AE, AG, AL, AM, AT, AU, AZ, BA, BB, BG, BR, BY, BZ, CA, CH, CN, CO, CR, CU, CZ, DE, DK, DM, DZ, EC, EE, ES, FI, GB, GD, GE, GH, GM, HR, HU, ID, IL, IN, IS, JP, KE, KG, KP, KR, KZ, LC, LK, LR, LS, LT, LU, LV, MA, MD, MG, MK, MN, MW, MX, MZ, NI, NO, NZ, OM, PG, PH, PL, PT, RO, RU, SC, SD, SE, SG, SK, SL, SY, TJ, TM, TN, TR, TT, TZ, UA, UG, US, UZ, VC, VN, YU, ZA, ZM, ZW.

(84) Designated States (*regional*): ARIPO patent (GH, GM, KE, LS, MW, MZ, SD, SL, SZ, TZ, UG, ZM, ZW), Eurasian patent (AM, AZ, BY, KG, KZ, MD, RU, TJ, TM), European patent (AT, BE, BG, CH, CY, CZ, DE, DK, EE, ES, FI, FR, GB, GR, HU, IE, IT, LU, MC, NL, PT, RO, SE, SI, SK, TR), OAPI patent (BF, BJ, CF, CG, CI, CM, GA, GN, GQ, GW, ML, MR, NE, SN, TD, TG).

- (72) Inventor; and
- (75) Inventor/Applicant (for US only): **JACKSON, Graeme, Andrew** [GB/GB]; Eaton Truck Components Operations, European Engineering Centre, P.O. Box 11, Worsley Road North, Worsley, Manchester M28 5GJ (GB).
- (74) Agent: **HARRISON GODDARD FOOTE**; Orlando House, 11c Compstall Road, Marple Bridge, Stockport SK6 5HH (GB).

**Declaration under Rule 4.17:**

— of inventorship (Rule 4.17(iv)) for US only

**Published:**

— without international search report and to be republished upon receipt of that report

For two-letter codes and other abbreviations, refer to the "Guidance Notes on Codes and Abbreviations" appearing at the beginning of each regular issue of the PCT Gazette.

(54) Title: A SHIFT LEVER MECHANISM

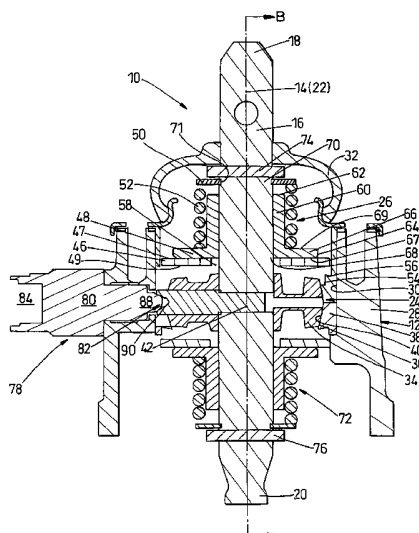

(57) Abstract: A shift lever mechanism (10) comprises a housing (12), having a longitudinal axis (14), and a lever (16), having a first end (18), a second end (20) and a longitudinal axis (22). The mechanism (10) further comprises pivoting means (24) adapted to facilitate pivoting of the lever (16) into predetermined positions. The mechanism (10) further comprises lever position indication means (78) operable to indicate disposal of the lever in one or more positions, and resilient means (92), operable to provide resistance to displacement of the lever (16) into a predetermined restricted position. The pivoting means (24) is attached to the lever (16) and is disposed in a retaining cup (38), being operable to pivot therein. The retaining cup (38) is disposed in the housing (12). The lever position indication means (78) and the resilient means being disposed on the pivoting means (24).

WO 2004/005764 A2

### **A shift lever mechanism**

The present invention relates to gear shift lever mechanisms, particularly to means  
10 operable to provide resistance to displacement, and means operable to indicate disposal,  
of the lever in one or more predetermined positions.

Normally, the shifting of ratios in a transmission system is effected by a shift finger  
acting on a set of transmission forks in the transmission. The shift finger is acted on by a  
15 shift lever extending outside the transmission and supported in a supporting mechanism.

Conventionally, on a rear driven vehicle, the shift lever is directly operable on the  
transmission system and is mounted in a housing extending from the top thereof. On a  
forward driven vehicle, the shift lever is normally remotely operable on the transmission  
20 system by means of a remote control shift assembly. The remote control shift assembly  
normally comprises a series of levers, or other means such as, for example, cables or  
hydraulic mechanisms, to which the shift lever is connected.

Known shift lever supporting mechanisms comprise an enlarged spherical portion  
25 disposed on the shift lever. The spherical portion is arranged in the mechanism in a  
retaining cup and is operable, through sphere-to-sphere engagement, to pivot therein to  
perform shifting operations. The retaining cup is housed in a housing through which the  
lever extends.

30 Shift lever mechanisms also generally comprise biasing means operable to provide a  
biasing force on the lever when it is shifted from a predetermined neutral position.

Known biasing means generally comprise a pair of diametrically opposing return pins operable to contact opposite side surfaces of the lever. The return pins are disposed along an axis transverse to that of the lever in a biased neutral position and are operable to apply a biasing force on the lower regions of the side surfaces of the lever. A gap, due to manufacturing tolerances, normally exists between each side surface and the associated return pin.

In use, pivotal displacement of the lever, from a neutral position, causes it to abut the relevant return pin and, on further displacement of the lever, displaces the return pin against the biasing force of a spring, thereby applying a returning force on the lever operable to encourage the lever back into the neutral position.

Means operable to provide resistance to displacement of the lever into a predetermined position is usually in the form of a biased detent pin, disposed in a transverse direction relative to the return pin, and adapted to provide resistance to displacement thereof. Because the resistance is provided relatively remote from the user, that is, at a distal end of the lever, and through biasing means, the user experiences undesirable distant and non-responsive feel in the shifting action. Further, because of the relative remoteness of the detent from the user a relatively large spherical portion is required to provide sufficient leverage on the return pin to overcome the resistance provided by the detent pin. Furthermore the resistance is only applicable on the lever in a direction in which a return pin is disposed.

Means operable to indicate disposal of the lever in one or more predetermined positions are usually suitably disposed to be actuated by the return pin or the detent pin. Again this is undesirable because of the above mentioned disadvantages.

The abovementioned known mechanisms experience undesirable movement of the lever due to biasing means, in the form of return pins, being disposed only in limited directional positions relative to displacement of the lever. In order to have a completely biased lever it would be necessary to have a return pin disposed in each direction in

which the lever is displaceable. This would clearly be uneconomic as each return pin requires a hole machined into the housing in which it is disposed.

Further, the gap between each side surface of the lever and the associated return pin  
5 translates into undesirable movement of the lever, which is felt by a user.

Furthermore, the disposition of the return pins, transverse to the longitudinal axis of the housing, and the length of travel required in the pins to provide the desired biasing force, dictates the overall minimum width of the mechanism.

10

It is desirable for the user to experience a positive feel and positional certainty when the lever is displaced into predetermined positions, including neutral positions.

Further, it is desirable to increase the functional efficiency of shift lever mechanisms and  
15 to reduce costs related to manufacturing thereof.

Furthermore, a compact mechanism, the size of which is not dictated by elements thereof extending radially outwards from the longitudinal axis of the housing, is desirable.

20 It is an object of the present invention to provide a shift lever mechanism operable to provide the user with positive feel and positional certainty of the lever.

It is also an object of the present invention to provide a shift lever mechanism with increased functional efficiency.

25

Further, it is an object of the present invention to provide a shift lever mechanism having relatively lower manufacturing costs.

Furthermore, it is an object of the present invention to provide a shift lever mechanism  
30 which is compact, the size of which is not dictated by elements thereof extending radially outwards from the longitudinal axis of the housing.

According to a first aspect of the present invention a shift lever mechanism comprises a housing, a lever having a longitudinal axis, pivoting means adapted to facilitate pivoting of the lever into a plurality of positions, and lever position indication means operable to  
5 indicate disposal of the lever in one or more predetermined positions, characterised in that the lever position indication means is actuated by the pivoting means.

The lever position indication means may comprise, for each predetermined position of the lever to be indicated, transducer means and actuation means.

10

The transducer means may comprise an electrical switch, which may be a potentiometer.

Alternatively, the transducer means may comprise an air valve.

15 The actuation means advantageously comprises a member and a receiver adapted to receive the member therein. The member may be disposed on the transducer means and the receiver may be disposed on the pivoting means.

The transducer means may be disposed in the housing preferably along an axis extending  
20 radially outwards and, more preferably, substantially perpendicular relative to the longitudinal axis of the housing.

Advantageously, at least part of the transducer means, preferably the member, is displaceable relative to at least part of the pivoting means, preferably the receiver. The  
25 displacement of the part is preferably along an axis extending radially outwards relative to the pivoting means.

According to a second aspect of the present invention a shift lever mechanism comprises a housing, a lever having a longitudinal axis, pivoting means adapted to facilitate  
30 pivoting of the lever into a plurality of positions, and resilient means, operable to provide

resistance to disposal of the lever in one or more predetermined positions, characterised in that the resistance is provided by the pivoting means.

The resilient means may comprise a resilient member and a detent. The detent is preferably disposed on the pivoting means and the member preferably disposed on the housing substantially along an axis extending radially outwards from the pivoting means. The member is preferably displaceable relative to the detent.

In relation to any of the abovementioned embodiments of the present invention, the pivoting means may comprise a spherical element advantageously disposed in a retaining cup and operable to pivotally move therein by sphere-to-sphere engagement therewith.

The spherical element may be fixed to the lever thereby forming a pivot point on the lever. The spherical element may be fixed to the lever by means of a retaining pin. Alternatively, the spherical element may form an integral part of the lever.

The lever may extend through the spherical element to form an arrangement substantially coaxial therewith.

The spherical element is preferably disposed on the lever intermediate first and second ends thereof.

The spherical element is preferably formed from a plastics material. Alternatively, the spherical element may be formed from a metallic material.

The retaining cup may be formed from a plastics material. Alternatively, the retaining cup may be formed from a metallic material.

The retaining cup may be disposed in the housing and may be formed from more than one part.

Alternatively, the pivoting means may comprise a plurality of pins attached to each other in such a way as to form a pivotable arrangement.

The present invention will now be described further, by way of example, with reference  
5 to the accompanying drawings, in which:

Figure 1 is a shift lever mechanism according to the present invention, in section through A-A, showing the lever disposed in a biased neutral position;

10 Figure 2 is the shift lever mechanism of Figure 1, in section through B-B, showing the lever disposed in a neutral position;

Figure 3 is the shift lever mechanism of Figures 1 and 2, in section through B-B, showing the lever disposed intermediate the neutral position and a predetermined position,  
15 engaging resilient means;

Figure 4 is the shift lever mechanism of the abovementioned figures, in section through B-B, showing the lever disposed in a predetermined position having overcome the resilient means; and,  
20

Figure 5 is the shift lever mechanism of the abovementioned figures, in section through A-A, showing the lever disposed in a predetermined position;

Referring to the drawings there is shown a shift lever mechanism 10 comprising a  
25 housing 12, having a longitudinal axis 14, a lever 16, having a first end 18, a second end 20 and a longitudinal axis 22, pivoting means 24, and biasing means 26.

The housing 12 is cylindrical, formed around the longitudinal axis 14, and comprises a wall 28, having an inner surface 30, and a cover 32.  
30

The lever 16 is formed from an elongate member having an external diameter and, in a neutral position, is disposed within the housing 12 along the longitudinal axis 14 thereof.

5 The pivoting means 24 comprises a spherical element 34, having an outer spherical surface 36, and a retaining cup 38, having an inner spherical surface 40. The retaining cup 38 is operable to retain the spherical element 34 therein and to provide pivotal displacement of the spherical element 34, about a pivot point 42, by engagement of the outer spherical surface 36 thereof with the inner spherical surface 40 of the retaining cup 38.

10

The retaining cup 38 may be formed from two or more pieces facilitate assembly of the mechanism.

The spherical element 34 and the retaining cup are formed from a plastics material.

15

Alternatively, they may be formed from a metallic material.

The lever 16 extends through the spherical element 34 and is fixed thereto, intermediate the first and second ends 18 and 20 thereof, by retaining pin 44. The lever 16 is therefore pivotable about the pivot point 42.

20

The biasing means 26 comprises first and second elements, 46 and 48, adapted to be displaceable along the longitudinal axis 22 of the lever 16, a third element 50 adapted to be fixed relative to the lever 16, and a biasing element in the form of a spring 52 disposed intermediate the second and third elements, 48 and 50, respectively.

25

The biasing means also comprises stop means 54 in the form of a region of lesser diameter disposed on the inner surface 30 of the housing wall 28 as an abutment 56. The abutment 56 may form part of the retaining cup 38 to reduce manufacturing costs.

30

The first element 46 is in the form of an annular disk having an external diameter sufficiently small to be displaceable within the housing 12 in the direction of the

longitudinal axis 14 thereof, and sufficiently large as to abut the abutment 56 disposed on the inner surface 30 of the housing wall 28. The first element 48 also comprises a bearing face 47 and an axially opposing abutment face 49. The first element 28 also comprises an aperture 58 extending axially therethrough.

5

The second element 48 is in the form of a bush, of top hat shape, having a region of lesser external diameter 60 extending to a top end 62 and a region of greater external diameter 64 defining a rimmed end 66. The rimmed end 66 comprises a rimmed end face 67 and a biasing face 69. The second element 48 also comprises an aperture 68 extending axially therethrough.

10

The third element 50 is in the form of annular disk having an aperture 70 extending axially therethrough.

15 In an assembled state, the lever 16 extends through the aperture 58 of the first element 46. The diameter of the aperture 58 is greater than the external diameter of the lever 16 such that the first element 46 is displaceable in the direction of the longitudinal axis 22 of the lever 16 whilst disposed other than perpendicular to thereto.

20 The lever 16 further extends through the aperture 68 of the second element 48. The diameter of the aperture 68 is greater than the external diameter of the lever 16, such that the second element 48 is slidable along the longitudinal axis 22 of the lever 16, over the outer surface thereof.

25 The rimmed end 66 of the second element 48 is disposed such that the rimmed end face 67 abuts the bearing face 47 of the first element 46.

The lever 16 further extends through the aperture 70 of the third element 50. The diameter of the aperture 70 is less than the external diameter of the lever 16. A region of the third element 16 around the aperture 70 extends into the external surface of the lever 16 and is thereby fixed thereto.

30

The biasing element 52 is disposed to surround the region of lesser diameter 60 of the second element 48 and extend from abutment with the biasing face 69 of the rimmed end 66 to abutment with the third element 50.

5

The abovementioned pivoting and biasing assembly is retained within the housing by retaining pins 74 and 76 disposed on the lever 16 in the region of the first and second ends 18 and 20 respectively thereof. The lever 16 extends further for user interface beyond the first end 18 and engagement with a transmission system beyond the second end 20.

10

As shown in the drawings, biasing of the lever 16 may be optimised by second biasing means 72 disposed on the lever to oppose the abovementioned first biasing means 26, that is, such that the pivoting means 24 is disposed on the lever 16 intermediate the first and second biasing means, 26 and 72 respectively, thereby improving the reaction and balance of the lever 16 in response to the biasing forces.

15

The second biasing means 72 comprises the same components, and the same assembly thereof, as the first biasing means 26.

20

Figures 1 and 2 show the lever, in use, in a neutral position, wherein each first element 46 is substantially perpendicular to the longitudinal axis 22 of the lever 16 and each biasing element 52 is, therefore, extended to support and balance the lever 16 in that neutral position.

25

Figures 3 and 4 show the lever 16, in use, disposed in a predetermined position, pivoted along a first plane, defined by section line B-B, and Figure 5 shows the lever 16, in use, disposed in a predetermined position pivoted along a second plane, defined by section line A-A, that is, substantially transverse to that of the first plane.

30

Referring to Figures 3 and 4, the first element 46 is axially fixed relative to the longitudinal axis 14 of the housing 12, to form a bearing platform operable to engage with the second element 48.

5 In use, the third element 50 is axially fixed relative to the lever 16 and, on pivotal displacement of the lever, applies a force on a region of the biasing element 52 adjacent the direction in which the lever is pivoted. The applied force compresses the biasing element between the third element 50 and the biasing face 69 of the second element 48. The second element 48 is slidable along the lever 16 to allow the lever to pivot. However,  
10 the greater the pivotal displacement, the greater the force urging it towards the first element 46, which it is prevented from travelling beyond by engagement therewith.

Therefore, the rimmed end face 67, of the second element, bears onto the bearing face 47, of the first element, to produce a returning biasing force which, through the biasing  
15 element 52 and the third element 50, is applied to the lever 16 and thereby biases the lever into the neutral position. The returning biasing force is enhanced by the ability of the second element to slide along the longitudinal axis of the lever.

Simultaneously, as the third element 50 applies a force which compresses the biasing  
20 element 52 adjacent the direction in which the lever is pivoted, it also applies a cooperative extending force to the biasing element 52 diametrically opposite the compressing force, which is also operable to bias the lever into the neutral position.

Also simultaneously, the second biasing means is operable in the same manner, as the  
25 first biasing means described above, to optimise the reaction and balance the biasing effect on the lever.

Referring to Figures 1 and 5, the shift lever mechanism 10 also comprises lever position  
30 indication means 78 operable to indicate disposal of the lever 16 in the neutral position.

The lever position indication means 78 comprises a switch 80 operable to engage with switch actuation means 82 to form an electrical signal when the lever 16 is disposed in the neutral position.

5 The switch 80 comprises a connection end 84 and a contact end 86 and is disposed in the wall 28 of the housing 12 along an axis extending radially outwards from the spherical element 34. The switch 80 is displaceable along the axis in which it is disposed and is biased towards the spherical element 34 such that the contact end 86 is in contact therewith. The connection end 84 is connected to a user interface such as, for example, a  
10 visual or audio indicator.

The switch actuation means 82 comprises a member 88 disposed on the contact end 86 of the switch 80 and a member receiver 90 disposed on the spherical element 34. The member 88 is suitably shaped to ride over the surface of the spherical element 34 as the  
15 lever 16 is displaced into predetermined positions, as shown in Figure 5. The member receiver 88 is suitably disposed such that on disposal of the lever 16 in the neutral position the member receiver 90 aligns with the member 88 and receives it therein, as shown in Figure 1, thereby forming an electrical connection within the switch 80. The electrical connection forms an electrical signal, which actuates the user interface thereby  
20 indicating that the lever 16 is in the neutral position.

Referring to Figures 2 to 4, the shift lever mechanism 10 also comprises resilient means 92 operable to provide resistance to displacement of the lever 16 into a restricted position such as, for example, a position which shifts the transmission into a reverse gear.

25

Figures 2 to 4 show progressive displacement of the lever 16 into the restricted position.

The resilient means comprises a resilient member 94 and a detent 96.

30 The resilient member 94 is disposed in the wall 28 of the housing 12 along an axis extending radially outwards from the spherical element 34. The resilient member 94 is

displaceable along the axis in which it is disposed and is biased towards the spherical element 34 such that it is in contact therewith. The resilient member 94 has a contact end 98 suitably shaped to ride over the surface of the spherical element 34 when the lever 16 is disposed in other positions and to engage with the detent 96 during displacement of the lever 16 into the restricted position.

The detent 96 is suitably disposed on the spherical element 34 to engage with the resilient member 94 only when an attempt is being made to displace the lever 16 into the restricted position.

10

In use, on an attempt to displace the lever 16 into the restricted position, the resilient member 94 engages the detent 96, which provides resistance to further displacement of the lever 16 in the direction of the restricted position. Increasing the force applied to the lever 16 in the direction of the restricted position, sufficient to overcome the bias applied to the resilient member 94, allows the resilient member 94 to ride over the detent 96, thereby allowing the lever 16 to be disposed in the restricted position.

It will be seen from the description that the present arrangement enables a very compact shift lever assembly to be produced. It can have a reduced height above the transmission when compared to known devices and be smaller because the need for a large spherical pivot element is avoided and the compact biasing means is located on the lever.

Whilst the assembly can work with one biasing means 26, it is preferred to have one above the pivot axis defined by the spherical element 34 and one below it 72. This provides a more balanced feel to the shift operation and facilitated easier design and construction of the assembly.

Throughout the description and claims of this specification the words "comprise" and variations of the word, such as, for example "comprising" and "comprises", mean "including but not limited to", and are not intended to exclude other components or integers.

## CLAIMS

5

1. A shift lever mechanism comprising a housing, a lever having a longitudinal axis, pivoting means adapted to facilitate pivoting of the lever into a plurality of positions, and lever position indication means operable to indicate disposal of the lever in one or more predetermined positions, characterised in that the lever position indication means is actuated by the pivoting means.

10

2. A shift lever mechanism as claimed in Claim 1, wherein the lever position indication means comprises, for each predetermined position to be indicated, transducer means and actuation means.

15

3. A shift lever mechanism as claimed in Claim 2, wherein the transducer means comprises a switch.

20

4. A shift lever mechanism as claimed in Claim 3, wherein the switch comprises a potentiometer.

5. A shift lever mechanism as claimed in Claim 2, wherein the transducer means comprises an air valve.

25

6. A shift lever mechanism as claimed in Claims 2 to 5, wherein the actuation means comprises a member and a receiver, adapted to receive the member therein.

7. A shift lever mechanism as claimed in Claim 6, wherein the member is disposed on the transducer means and the receiver is disposed on the pivoting means.

30

8. A shift lever mechanism as claimed in Claim 2 to 7, wherein the transducer means is disposed in the housing.
9. A shift lever mechanism as claimed in Claims 2 to 8, wherein the transducer means is disposed along an axis extending radially outwards relative to the longitudinal axis of the housing.
10. A shift lever mechanism as claimed in Claims 2 to 9, wherein the transducer means is disposed substantially perpendicular relative to the longitudinal axis of the housing.
11. A shift lever mechanism as claimed in Claims 2 to 10, wherein at least part of the transducer means is displaceable relative to at least part of the pivoting means.
12. A shift lever mechanism as claimed in Claims 6 to 12, wherein the member is displaceable relative to the receiver.
13. A shift lever mechanism as claimed in Claims 11 and 12, wherein the displacement is substantially along an axis extending radially outwards relative to the pivoting means.
14. A shift lever mechanism comprising a housing, a lever having a longitudinal axis, pivoting means adapted facilitate pivoting of the lever into a plurality of positions, and resilient means, operable to provide resistance to displacement of the lever in one or more predetermined positions, characterised in that the resistance is provided by the pivoting means.
15. A shift lever mechanism as claimed in Claim 14, wherein the resilient means comprises a resilient member and a detent.
16. A shift lever mechanism as claimed in Claim 15, wherein the detent is disposed on the pivoting means.

17. A shift lever mechanism as claimed in Claims 15 and 16, wherein the resilient member is disposed on the housing.
18. A shift lever mechanism as claimed in Claim 17, wherein the resilient member is  
5 disposed substantially along an axis extending radially outwards from the pivoting means.
19. A shift lever mechanism as claimed in Claims 15 to 18, wherein the resilient member is displaceable relative to the detent.
- 10 20. A shift lever mechanism as claimed in any of the preceding claims, wherein the pivoting means comprises a spherical element.
21. A shift lever mechanism as claimed in Claim 20, wherein the spherical element is  
15 disposed in a retaining cup and is operable to pivotally move therein.
22. A shift lever mechanism as claimed in Claim 21, wherein at least one of the spherical element and cup is formed from a plastics material.
- 20 23. A shift lever mechanism as claimed in Claim 21, wherein at least one of the spherical element and cup is formed from a metallic material.
24. A shift lever mechanism as claimed in Claims 20 to 23, wherein the spherical element  
is fixed to the lever thereby forming a pivot point on the lever.
- 25 25. A shift lever mechanism as claimed in Claim 24, wherein the spherical element is fixed to the lever by means of a retaining pin.
26. A shift gear mechanism as claimed in Claims 20 to 23, wherein the spherical element  
30 forms an integral part of the lever thereby forming a pivot point on the lever.

27. A shift lever mechanism as claimed in Claims 20 to 26, wherein the lever extends through the spherical element to form an arrangement substantially coaxial therewith.

5

10

15

20

25

30

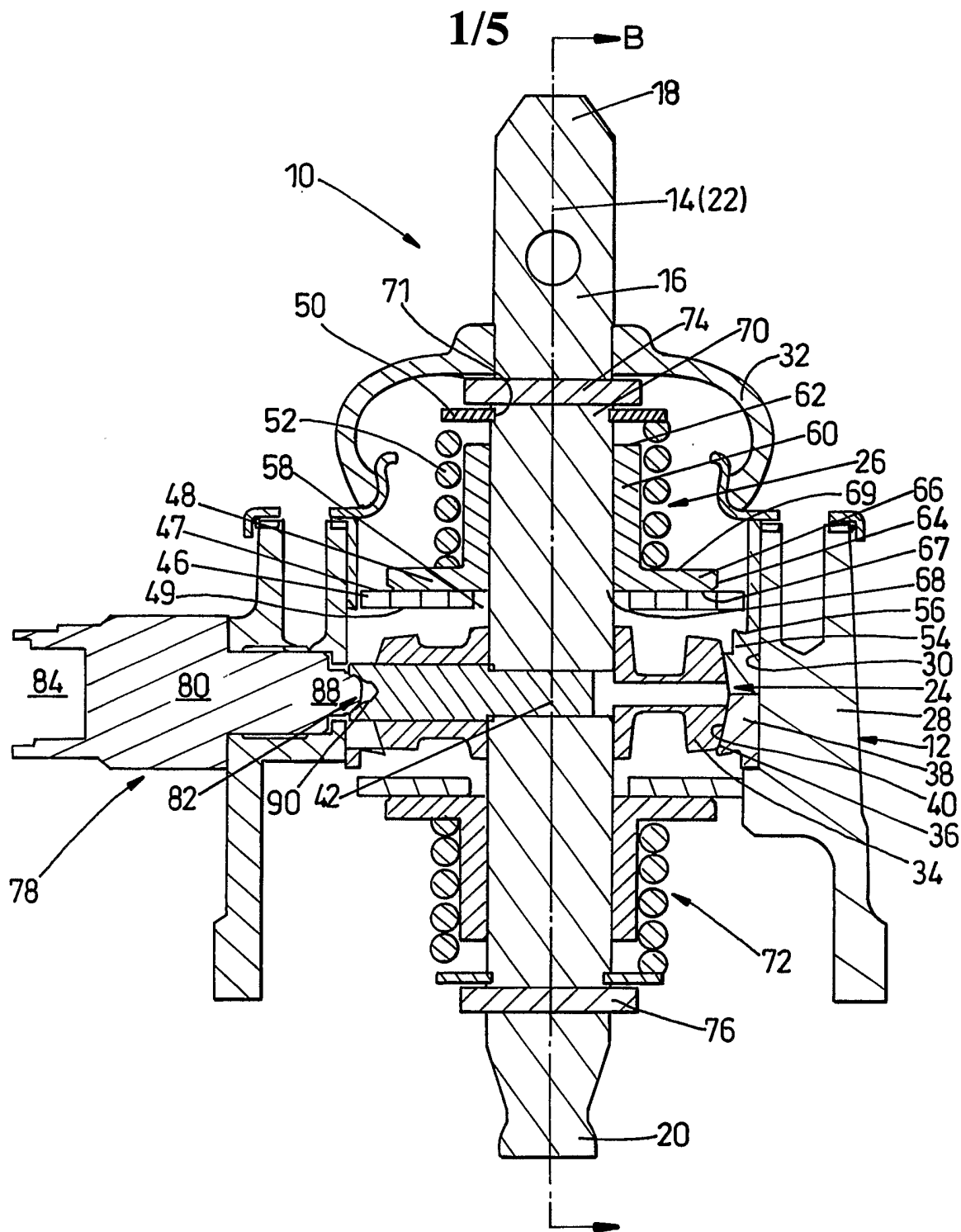

*Fig. 1*

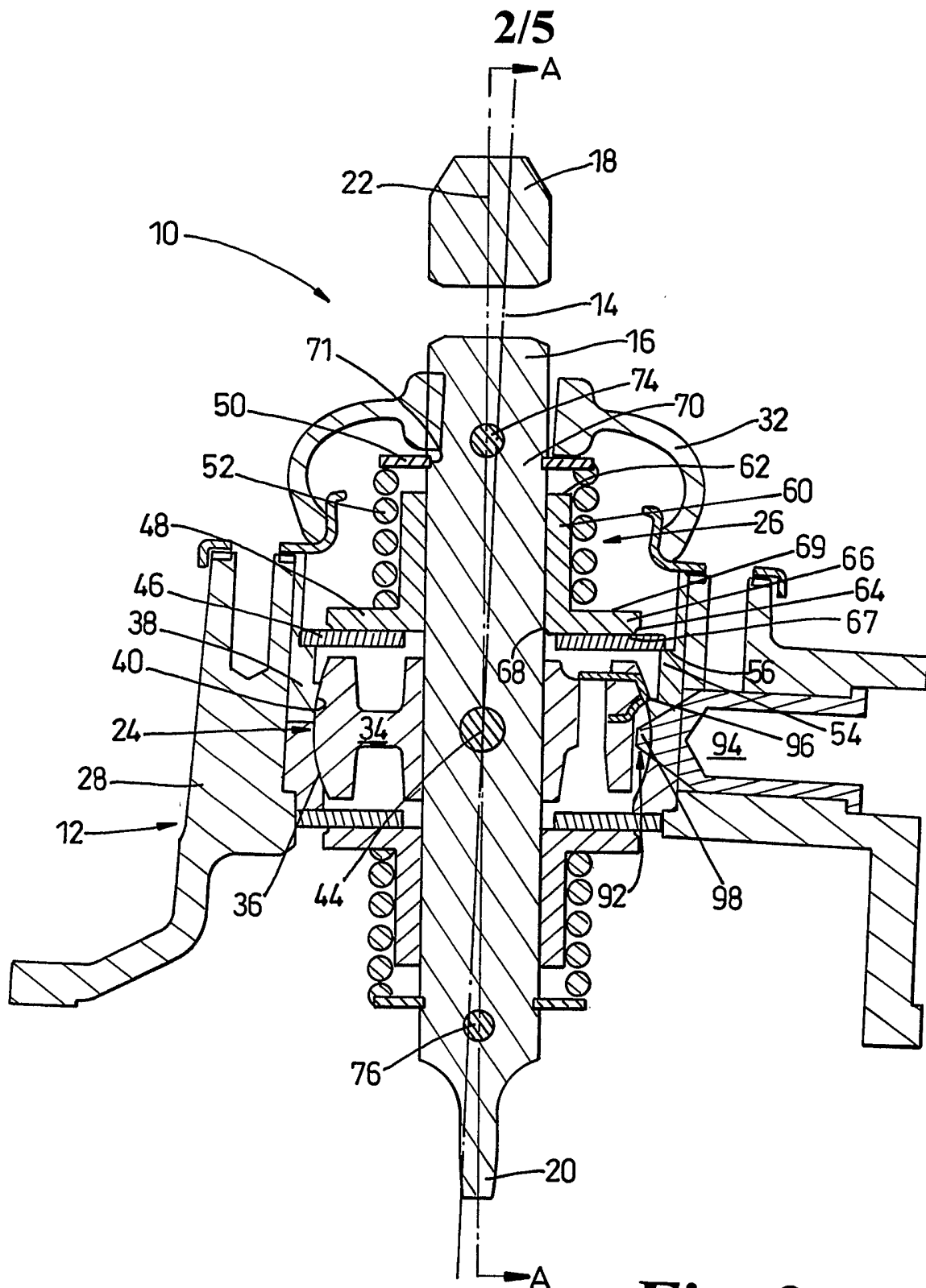

**Fig. 2**

