



- (51) **International Patent Classification:**
G06T 7/00 (2006.01) A61B 6/00 (2006.01)
G06T 15/00 (2006.01)
- (21) **International Application Number:**
PCT/US2009/065288
- (22) **International Filing Date:**
20 November 2009 (20.11.2009)
- (25) **Filing Language:** English
- (26) **Publication Language:** English
- (30) **Priority Data:**
12/276,006 21 November 2008 (21.11.2008) US
- (71) **Applicant (for all designated States except US):** HOLOGIC, INC. [US/US]; 250 Campus Drive, Marlborough, MA 01752 (US).
- (72) **Inventors; and**
- (75) **Inventors/Applicants (for US only):** RUTH, Chris [US/US]; 7 Cedar Knoll, Boxford, MA 01921 (US). SMITH, Andrew [US/US]; 8 Glen Road, Lexington, MA 02420 (US). STEIN, Jay [US/US]; 314 Dartmouth Street, Boston, MA 02116 (US).
- (74) **Agent:** MCGUINNESS, Lindsay; Hologic Inc., 250 Campus Drive, Marlborough, MA 01752 (US).

- (81) **Designated States (unless otherwise indicated, for every kind of national protection available):** AE, AG, AL, AM, AO, AT, AU, AZ, BA, BB, BG, BH, BR, BW, BY, BZ, CA, CH, CL, CN, CO, CR, CU, CZ, DE, DK, DM, DO, DZ, EC, EE, EG, ES, FI, GB, GD, GE, GH, GM, GT, HN, HR, HU, ID, IL, IN, IS, JP, KE, KG, KM, KN, KP, KR, KZ, LA, LC, LK, LR, LS, LT, LU, LY, MA, MD, ME, MG, MK, MN, MW, MX, MY, MZ, NA, NG, NI, NO, NZ, OM, PE, PG, PH, PL, PT, RO, RS, RU, SC, SD, SE, SG, SK, SL, SM, ST, SV, SY, TJ, TM, TN, TR, TT, TZ, UA, UG, US, UZ, VC, VN, ZA, ZM, ZW.
- (84) **Designated States (unless otherwise indicated, for every kind of regional protection available):** ARIPO (BW, GH, GM, KE, LS, MW, MZ, NA, SD, SL, SZ, TZ, UG, ZM, ZW), Eurasian (AM, AZ, BY, KG, KZ, MD, RU, TJ, TM), European (AT, BE, BG, CH, CY, CZ, DE, DK, EE, ES, FI, FR, GB, GR, HR, HU, IE, IS, IT, LT, LU, LV, MC, MK, MT, NL, NO, PL, PT, RO, SE, SI, SK, SM, TR), OAPI (BF, BJ, CF, CG, CI, CM, GA, GN, GQ, GW, ML, MR, NE, SN, TD, TG).

Published:

— without international search report and to be republished upon receipt of that report (Rule 48.2(g))

(54) **Title:** SYSTEM AND METHOD FOR GENERATING A 2D IMAGE FROM A TOMOSYNTHESIS DATA SET

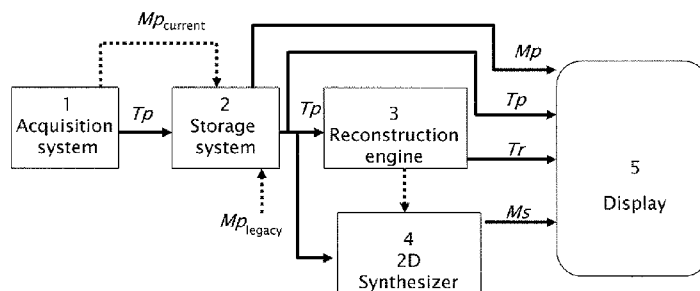

Figure 1

(57) **Abstract:** A 2D mammogram image is synthesized from at least one of tomosynthesis projection images and/or the tomosynthesis reconstructed image data. In a simplest form, the mammogram may be synthesized by selecting one of the tomosynthesis projection images for display as a synthesized mammogram. Other methods of synthesizing a mammogram include re-projecting and filtering projection data and/or reconstructed data. The synthesized mammogram is advantageously displayed together with at least a portion of the reconstructed data to aid in review of the reconstructed data. The present invention thus provides a familiar image which may be used to facilitate review of a tomosynthesis data set.

WO 2010/059920 A2

SYSTEM AND METHOD FOR GENERATING A 2D IMAGE FROM A TOMOSYNTHESIS DATA SET

[0001] RELATED APPLICATIONS

[0002] This patent application is a continuation-in-part and claims priority under 35 U.S.C. §120 to U.S. Patent Application 12/276,006 filed 11/21/2008 which is a continuation in part of U.S. Patent Application 11/827,909 Filed July 13, 2007, which is a continuation of application no. 11/604,069 filed on Nov. 24, 2006, now abandoned, which is a continuation-in-part of application no. 11/271,050, filed on November 10, 2005 and which is a continuation in part of application No. 10/305,480 filed on November 27, 2002, now patent 7,123,684 and which is a continuation in part of application no 10/723,486 filed November 26, 2003. Both 11/827,909 and 11/271,050 claim priority under 35 U.S.C. §119 to provisional application 60/628,516 filed November 15, 2004 and application 60/631,296 filed November 26, 2004.

[0003] FIELD

[0004] This patent specification pertains to x-ray mammography and tomosynthesis, and more specifically to techniques and equipment for acquiring and/or synthesizing, processing, storing and displaying mammograms, tomosynthesis projection images, synthesized two-dimensional (2D) images and tomosynthesis reconstructed images, and to medical image softcopy reading systems, to hanging protocols and to other medical image display features.

[0005] BACKGROUND

[0006] Mammography has long been used to screen for breast cancer and other abnormalities and for diagnostics. Traditionally, mammograms were formed on X-ray film, but more recently flat panel digital imagers have been introduced that acquire a mammogram in digital form and thereby facilitate analysis and storage and provide other benefits as well. Further, X-ray tomosynthesis of the

breast has been proposed recently, as discussed in the earlier-filed applications identified above, and clinical testing has been carried out. The assignee of this patent specification, Hologic, Inc., has demonstrated at trade shows in this country a fused, multimode mammography/tomosynthesis system that takes either or both types of images, either while the breast remains immobilized or in different compressions of the breast.

[0007] Dedicated breast tomosynthesis systems also have been proposed. However, in clinical use it can be desirable for a number of reasons to assess both tomosynthesis images and conventional mammograms of the patient's breast. For example, the decades of conventional mammograms have enabled medical professionals to develop valuable expertise. Mammograms offer good visualization of micro-calcifications, and can offer higher spatial resolution when compared with tomosynthesis images. While tomosynthesis images provided by dedicated breast tomosynthesis systems in the art have other desirable characteristics (i.e., better visualization of structures), such systems do not leverage the existing interpretation expertise of medical professionals. In addition, the increased mobility of patient data and varied capabilities of imaging centers will require the ability to provide mechanisms that enable images to be displayed using whatever resources are available at the imaging center, without regard to the original acquisition format of the image.

[0008] **SUMMARY**

[0009] Tomosynthesis as used in the systems and methods disclosed in this patent specification typically involves acquiring a plurality of tomosynthesis projection images T_p at respective angles relative to the breast, and reconstructing therefrom a plurality of tomosynthesis reconstructed images T_r representative of breast slices that have selective thicknesses. According to one aspect of the invention, a synthesized 2D image is generated using at least one of the tomosynthesis projection images T_p and/or the tomosynthesis reconstructed

images T_r . The reconstructed images may be reconstructed using any one of a variety of techniques, including but not limited to filtered back projection in either spatial or frequency domain, maximum likelihood reconstruction, iterative reconstruction, reconstruction using algebraic methods, minimum likelihood or other known or developed three dimensional reconstruction methods. The may be obtained using projection data obtained based on any coordinate system, including a Cartesian coordinate system, a cone beam coordinate system, where the cone beam coordinate system may be defined by geometric information of an associated tomosynthesis acquisition system or alternatively may be a virtualized cone beam coordinate system defined relative to a 'virtual' tomosynthesis acquisition system. Further, following reconstruction, the reconstructed data may projected onto any other different coordinate system; for example, reconstruction data obtained using a first coordinate system may be projected into a second, different coordinate system. For example onto reconstructed data may be projected onto a plane of a different orientation, a cone beam reconstruction may be projected onto a virtual cone beam coordinate system or a Cartesian coordinate system, etc. In summary, projection images may be reconstructed onto any first coordinate system and then projected onto any second, different coordinate system..

[0010] The synthesized 2 D image is referred to herein as a synthesized mammogram (M_s) or other synthesized 2D tomosynthesis image (T_{2d}). The synthesized 2D image may be generated using any combination of tomosynthesis projection data or reconstructed data generated using from, or projected onto, any coordinate system. The synthesized 2D image of the present invention is advantageously displayed together with tomosynthesis image data (T_r and/or T_p images) at a review workstation. With such an arrangement, a medical professional may utilize existing expertise gained from

past review of mammogram data to more efficiently assess and view the 3D tomosynthesis data, without independent acquisition of a mammogram.

[0011] In another embodiment, the synthesized 2D image Ms may be displayed together with an Mp image previously obtained for the patient, to enable comparison of like images using known methods before using the Tr data. Conversely, the method of synthesizing 2D images from Tp and/or Tr data may be used to compare mammograms obtained by a mammography-only machine against existing tomosynthesis data for a patient, thereby increasing the utility of tomosynthesis data by facilitating transport between systems of differing capabilities. Thus there are a variety of systems, including mammo only systems, tomo only systems and combo systems, which may benefit from the ability to synthesize a 2D image from tomosynthesis data, either for comparison with mammography data, or increasing the efficiency of diagnostic workflow.

[0012] Proper display techniques make the presentation of Ms, Mp, Tp and/or Tr images (collectively referred to here as T images) more effective and efficient for review by health professionals. When tomosynthesis projection images Tp are acquired, (with or without conventional 2D mammograms Mp) improved display methods facilitate the display of both T and Mp and/or Ms images.

[0013] Effective display approaches also are desirable when tomosynthesis images Tp and/or Tr that are acquired at one time need to be compared to mammograms Mp and/or to tomosynthesis images Tp and/or Tr acquired at a different time. In situations where an Mp image is not available for a particular time, but Tp and/or Tr images are available, the present invention enables generation of a synthesized mammogram image Ms. Effective displays also are desirable when only Tr and/or Tp images are being displayed.

[0014] An Ms image may be provided in any number of ways using one or more Tp images and/or one or more Tr images. A variety of techniques for generating Ms images will be described in more detail below. The Ms image may be

dynamically generated prior to display, or alternatively may be pre-generated and stored. For example, Ms images may be dynamically synthesized prior to display of Tr /Tp images, may be generated upon acquisition of the Tp images and stored with Tp images, or may be generated following reconstruction of the Tr images, using a combination of Tp and Tr images.

[0015] The display may be adapted to provide concurrent, toggled, overlaid or cine display of any combination of one or more of the Ms, Mp, Tp and Tr images. Concurrent display may be in the form of a side by side view, either on the same display or on neighboring displays, or alternatively may be in the form of a thumbnail scout view of one image provided within another image. When viewing images concurrently, the present invention supports reflective marking of the different images; for example should the technician mark an area of interest on the mammogram (or tomo slice) or move a marker on the mammogram, the mark and/or movement of the mark is reflected in the appropriate location of the tomo slice (or mammogram).

[0016] Another display issue relates to Computer Aided Detection (CAD) methods that use computer analysis of images to identify locations and possibly other characteristics of suspected abnormalities. CAD marks currently are placed on or are otherwise associated with mammogram images Mp, but it may be useful to place them at the appropriate location on Tr and/or Tp images or to otherwise associate them with Tr/Tp images. Conversely, it may be desirable to obtain CAD marks by processing Tp and/or Tr images, and place them at appropriate locations on Mp images, or alternatively at appropriate locations in an Ms image.

[0017] BRIEF DESCRIPTION OF DRAWINGS

[0018] FIG. 1 is a block diagram illustrating flow of data through a system which includes a combination mammography/tomosynthesis acquisition station or a tomosynthesis only acquisition station and where reconstruction of

tomosynthesis slice images Tr and synthesis of the Ms images occurs after storage of acquired tomosynthesis projection images Tp.

- [0019] FIG. 2 is a block diagram illustrating flow of data through a system which includes a combination mammography/tomosynthesis acquisition station or a tomosynthesis only acquisition station and where the reconstruction of images Tr occurs before storage of the image data.
- [0020] FIG. 3 is a block diagram illustrating flow of data through a system which includes a mammography-only acquisition system, and where reconstruction of tomosynthesis slice images Tr and/or synthesis of the Ms images occurs after storage of acquired tomosynthesis projection images Tp. FIG. 3 illustrates an example where four units acquiring Tp images feed a single unit that reconstructs Tr images.
- [0021] FIG. 4 illustrates a concurrent display of an Ms image and a Tr in substantially same area on a screen, with an example of a non-numeric indication of a thickness and position in the breast of a breast slice represented by a Tr image.
- [0022] FIG. 5 illustrates a concurrent display of Ms and Mp images, at separate areas on a screen or as combined images.
- [0023] FIG. 6A illustrates a display of a Tr image, with an integrated window including a scout view of a 2D synthesized image, for use in guiding a medical professional's evaluation of the Tr data.
- [0024] FIG. 6B illustrates a display of a Tr image with an integrated window that includes both an Ms image and a legacy Mp image, shown as scout views, for use in guiding a medical professional's evaluation and workflow using the Tr image data.
- [0025] FIG. 7 illustrates a display of Ms/Mp/Tr/Tp images with CAD marks and a non-numeric indication of Tr images in which CAD marks exist;

- [0026] FIG. 8 illustrates a display of an MS image together with a Tr/TP image, wherein a region of interest marker placed in a first image is reflected into a second image;
- [0027] FIG. 9 is a block diagram illustrating exemplary components of an x-ray acquisition and display system that incorporates the 2D synthesis method of the present invention;
- [0028] FIG. 10 illustrates image planes of a mammogram and tomosynthesis slice images;
- [0029] Figs. 11a- 11c illustrate, respectively, tomosynthesis reconstruction into a Cartesian geometry, into a cone-beam geometry and into a virtual geometry; and
- [0030] FIG. 12 is a flow diagram provided to illustrate exemplary steps that may be performed in a 2D image synthesis process which uses tomosynthesis data.
- [0031] **DETAILED DESCRIPTION OF PREFERRED EMBODIMENTS**
- [0032] In describing preferred embodiments illustrated in the drawings, specific terminology is employed for the sake of clarity. However, the disclosure of this patent specification is not intended to be limited to the specific terminology so selected and it is to be understood that each specific element includes all technical equivalents that operate in a similar manner.
- [0033] The following abbreviations shall have the following definitions throughout this application. The notation M_p refers to a conventional mammogram, which is a two-dimensional projection image of a breast and encompasses both a digital image as acquired by a flat panel detector or another imaging device and the image after conventional processing to prepare it for display to a health professional or for storage, e.g. in the PACS system of a hospital or another institution. The term $M_{p_{current}}$ refers to a mammogram that is acquired by an acquisition system for patient diagnosis, while the term $M_{p_{legacy}}$ refers to a mammogram image of a patient that had been taken on a previous review of the

patient, for example one that is to be used for comparison against an $Mp_{current}$ to identify changes in a patient's breast structure.

[0034] Tp refers to an image that is similarly two-dimensional but is taken at a respective tomosynthesis angle between the breast and the origin of the imaging X-rays (typically the focal spot of an X-ray tube), and also encompasses the image as acquired as well as the image after being processed for display or for some other use. Tr refers to an image that is reconstructed from images Tp , for example in the manner described in said earlier-filed patent applications, and represents a slice of the breast as it would appear in a projection X-ray image of that slice at any desired angle, not only at an angle used for Tp or Mp images.

[0035] The term Ms refers to synthesized 2D projection images which simulate mammography images, such as a craniocaudal (CC) or mediolateral oblique (MLO) images, and are constructed using tomosynthesis projection images Tp , tomosynthesis reconstructed images Tr or a combination thereof. Ms images may be provided for display to a health professional or for storage in the PACS system of a hospital or another institution.

[0036] The terms Tp , Tr , Ms and Mp also encompasses information, in whatever form, that is sufficient to describe such an image for display, further processing, or storage. The images Mp , Ms , Tp and Tr typically are in digital form before being displayed, and are defined by information identifying properties of each pixel in a two-dimensional array of pixels. The pixel values typically relate to respective measured or estimated or computed responses to X-rays of corresponding volumes in the breast (voxels or columns of tissue). In a preferred embodiment, the geometry of the tomosynthesis images (Tr and Tp) and mammography images (Ms , Mp) are matched to a common coordinate system as described in U.S. Patent application serial number 11/667,650

"Matching Geometry Generation and Display of Mammograms and Tomosynthesis Images", filed November 15, 2005.

[0037] FIG. 1 illustrates flow of data in one example of an image generation and display system disclosed in this patent specification. An image data acquisition system 1 acquires tomosynthesis image data for Tp images of patients' breasts, and can take the form of and use the acquisition methods of any of the systems disclosed in said earlier-filed patent applications. If the system is a combo system, Mp images may also be generated (as indicated by dashed line and label Mp_{current} in Figure 1). Some dedicated tomosynthesis systems or combo systems may be adapted to accept and store legacy mammogram images (indicated via dashed line and legend Mp_{legacy} in Figure 1) in a Picture Archiving and Communication System (PACS) storage device 2, although it is not a requirement that any Mp images be acquired or pre-stored.

[0038] Following tomosynthesis image acquisition, the data describing projection images Tp are sent to storage device 2, which is preferably a DICOM-compliant PACS. When images are needed for display 5, the data Tp images are sent, from either acquisition system 1 or from storage device 2, to a computer system 3 configured as a reconstruction engine that can perform tomosynthesis reconstruction into images Tr representing breast slices of selected thickness and at selected orientations, as disclosed in said earlier-filed patent applications and detailed below. The computer system may be further configured with 2D synthesis functionality 4, which may operate substantially in parallel with reconstruction engine 3 to generate a synthesized 2D image (interchangeably referenced as T2d or Ms). The reconstructed slice images Tr are then sent to a display system 5 so that they can be viewed. If the reconstruction engine 3 is connected to display 5 via a fast link, then large datasets can be transmitted quickly. Other images, such as the Ms, Mp and/or

Tp images may also be forwarded to the display unit for concurrent or toggled viewing.

- [0039] Over time, there will likely be improvements to the acquisition systems and to the display systems, which may result in hardware and software upgrades and changes to reconstruction algorithms. This can create issues in viewing images taken previously. It may be important to be able to recall from storage and reconstruct an image that looks identical (or is at least comparable) to the way it looked when it was reconstructed and displayed in the past, or vice versa.
- [0040] Consider the example where an improvement in reconstruction algorithms improves image quality so as to allow detection of a cancerous lesion in an image where it was not visible using a previous version of the reconstruction algorithm and the then existing standard of care. While it could be useful to see older images processed with the newer algorithms, it may also be important to allow the re-display of images as they were viewed during an original detection/diagnosis. One way to accomplish this in accordance with the disclosure in this patent specification is to put a version number or some other information in the data for Tp images, which identifies the software and/or hardware versions of the Tp image data acquisition and/or Tr image reconstruction system at the time of acquisition, or to otherwise associate such information with the Tp images. During reconstruction at a later time, the reconstruction engine reads this version number or other similar information and reconstructs using the appropriate algorithm. Thus, system upgrades can maintain a library of older algorithms and/or hardware so as to be able to reconstruct using the proper technique. .
- [0041] In addition it may be desirable to port existing images, generated using systems having different capabilities, to new systems. For example a patient may have compiled a history of mammogram images associated with past screenings. Such a patient may be examined at a facility with updated

equipment, for example one that includes a dedicated tomosynthesis system. To compare historical information against existing diagnostic images it may be desirable to store such legacy Mp images, generate Ms images from a tomosynthesis acquisition of the dedicated tomo system and compare like-formatted representations.

[0042] Therefore, an alternative design of an image acquisition and display system of the present invention is illustrated in FIG. 2. In this example, the reconstruction unit 3 and 2D synthesizer 4 are directly coupled to the acquisition station 1, and it is the reconstruction images Tr and synthesized images Ms that are sent to storage system 2 for subsequent display on display devices 5, which may also store legacy Mp images. One advantage of the configuration of FIG. 2 is in the way it handles acquisition and synthesizing upgrades--if a new hardware/software version has a modified reconstruction algorithm, then all Tr images and Ms images reconstructed or synthesized from Tp image data taken after the upgrade will automatically reflect this new algorithm, and Tr and Ms images reconstructed or synthesized from Tp image data taken prior to the upgrade will have been reconstructed with the older version and properly stored as such. The images stored on a PACS will be the same as they were viewed by the radiologist or other health professional during the detection/diagnosis or other earlier review. Another advantage of the system of FIG. 2 is the reduced system reconstruction burden compared to the system in FIG. 1, where the reconstruction engine is just prior to the display. If there are multiple acquisition systems, for example four systems that are all pushing images to the display, then the reconstruction engine will need to reconstruct images at 4 times the rate of a reconstruction engine in a system having only one acquisition system, for the same total patient throughput.

[0043] FIG. 3 illustrates another image acquisition and display system which may benefit from the 2D image synthesizing process of the present invention. In

Figure 3, the image acquisition device 11 is a mammography only device. One advantage of digital imaging is the portability of data; it is conceivable that patients that switch between different imaging locations may be exposed to imaging equipment with different capabilities. For example, a patient may undergo an exam at an imaging center that includes a tomosynthesis only system, and subsequently undergo an exam at a location that includes a mammography only acquisition system, (or visa versa). In order for the medical professional to easily compare images to identify changes in the breast structure it would be desirable to synthesize a 2D mammogram from existing T_r and/or T_p data. In FIG. 3, storage device 2 is adapted to store both legacy M_p (if any) as well as legacy T_p images. Depending upon capabilities of the display device, (i.e., whether tomosynthesis data can be viewed), the system may include reconstruction unit 3. Other systems which have only the capability of viewing mammograms may not include this unit, and thus the unit and tomosynthesis data are all shown in dashed lines in Figure 3. In the system of Figure 3, when a mammogram M_p is acquired, it is either stored in storage device 2 or forwarded to display 5. T_p and/or T_r data are retrieved from the storage device and forwarded to the 2D synthesizer 4. The resulting M_s image is displayed together with the current M_p on display 5. It is envisioned that in such systems the 2D synthesizing software may be provided as a downloadable application that facilitates viewing of tomosynthesis data on existing mammography systems.

[0044] The question of which system design will place a greater burden on the PACS storage of an institution will depend upon the sizes of the raw projections T_p and of the reconstructed images T_r . In general, if the raw projections T_p are smaller than the reconstructed images T_r , it might be desirable to save in PACS the raw or preliminarily processed data for T_p images and reconstruct the final

Tr images on demand for display or other use. In all cases it may be desirable to keep both of these sizes as small as possible.

[0045] One way to reduce the size of an original dataset for a Tp image is to bin the projection Tp data to as large a pixel size as practical without reducing clinical efficacy of the final Ms, Tp or Tr images.

[0046] For storage, transmission to remote locations, and/or other purposes, the images can be formatted consistent with DICOM standards. For example, each raw or displayed projection image set, synthesized image or reconstructed slice image set for a single view is stored as a single Secondary Capture image instance according to DICOM. The image pixel data can be encoded in a selected compressed format (CODEC) that includes all projection or slice images.

[0047] As shown in Figures 1-3, the imaging and display system of the present invention includes a 2D synthesizer for generating 2D images simulating mammograms taken at both a CC and MLO orientation using a combination of one or more Tp and/or Tr images. A display of the system preferably should be able to display Ms, Mp and Tr (and/or Tp) images concurrently (either in separate windows on the display, on separate monitors of a technology workstation, or overlaid) or sequentially or in toggled mode, wherein the Ms, Mp, Tp and Tr images may be those currently acquired, or those that were acquired in previous studies. Thus, in general, the display can simultaneously or sequentially or in toggled mode display mammograms (Ms, Mp) and tomosynthesis images Tr (and/or Tp) from the current and previous studies. Tr slices can be reconstructed all to the same size, which can be the same as the size of an Mp or Ms image of the breast, or they can be initially reconstructed to sizes determined by the fan shape of the x-ray beam used in the acquisition and later converted to that same size by appropriate interpolate]on/extrapolation.

[0048] Images of different types and from different sources can be displayed in desirable size and resolution. For example, an image can be displayed in (1) Fit To View Port mode, in which the size of the displayed image size is maximized such that the entire imaged breast tissue is visible, (2) True Size mode, in which a display pixel on the screen corresponds to a pixel of the image, or (3) Right Size mode, in which the size of a displayed image is adjusted so that it matches that of another image that is concurrently displayed or with which the displayed image is or can be toggled. For example, if two images of the same breast are taken and are not the same size or do not have the same special resolution, provisions are made to selectively zoom in or zoom out one of them, or zoom both, such that they appear to be the same size on the screen when they are concurrently displayed or the user toggles between them, to facilitate comparison or to otherwise facilitate detection/diagnosis. Known interpolation/extrapolation and weighting techniques can be used in such re-sizing, and known image processing technology can be used to make other characteristics of the displayed images similar in a way that facilitates detection/diagnosis.

[0049] Selected hanging protocols are provided that are unique to the different types of images with which the disclosed system deals. As one example, the hanging protocols for 2D images (e.g. Ms or Mp images) and 3D images (e.g. Tr images) are linked so that when one type of image is displayed for a given breast the other type is displayed as well. For example, when the Ms/Mp image of a breast is displayed, a tile of the Tr images and/or of the Tp images is automatically displayed at the same time, with a desired hanging protocol that may involve scrolling or cine mode presentation, or may require user input so select a particular subset of the Tr and/or Tp images or a particular individual Tr/Tp image. Thus, a combined hanging protocol set can be provided for 2D and 3D images that are concurrently displayed (either on a common display on

adjacent displays, or overlaid) or toggled such that only one type is displayed at one time. In addition, the combined hanging protocol can include provisions for linked display of CAD information associated with one or both of the 2D and 3D images involved in the hanging protocol. Alternatively, the hanging protocols for 2D images are made different from those for 3D images. Methods of identifying which image corresponds to which image type in displays of Ms, Mp, Tr and/or Tp images are desirable. One example of such a method is illustrated in FIG. 4. An icon is used to identify an image type. In this non-limiting example, the symbol MS on the left image 300 indicates that it is a synthesized mammogram. The symbol T on the right image 310 indicates that it is a tomosynthesis slice image Tr. Similarly, a symbol Tp (not shown) can be used to indicate that the displayed image is a tomosynthesis projection image Tp, a symbol 2D may be used to indicate that it is a 2D image, and the symbol 3D (also not shown) can be used to indicate that an image on the display is a 3D image. Other symbols/icons serving a similar purpose can be used instead of, or in addition, to those identified above. In the alternative, the images can be displayed without an identification of the type of image. For example, a Tr image and an Mp or Ms image can be displayed at the same time or toggled without displaying an indication of the type of the image that is visible. This may be desirable in cases such as when a user has a familiar hanging protocol and does not need an express identification of the type of image.

[0050] The system described as a non-limiting example in this patent specification is capable of receiving and displaying selectively the tomosynthesis projection images Tp, the tomosynthesis reconstruction images Tr, the synthesized mammogram image Ms and/or the mammogram images Mp, or a single type, or any sub combination of types. It can receive images stored uncompressed, losslessly compressed, and lossily compressed. It can also include algorithms to decompress images sent in compressed format. The system has software to

perform reconstruction of tomosynthesis image data for images T_p into images T_r and software for synthesizing mammogram images M_s . Further, it can include software to generate 3D display images from the tomosynthesis reconstructed images T_r using standard known methods such as MIP (Maximum Intensity Projection), summing, and/or weighted summing algorithms. Figure 5 illustrates an exemplary display of an M_p image together with a 2D synthesized image; each image may be labeled to indicate whether the image is from a current acquisition, or based on legacy data. For example the M_p image may be a stored legacy mammogram, and the 2D M_s image may be generated from a current tomosynthesis acquisition and may be provided as an initial view to guide the medical professional's perusal of the tomosynthesis data.

Alternatively, the M_p image may be based on a current acquisition, for example via a combo mammo/tomo system or by a mammography-only system, and the M_s image may be generated from previously stored tomosynthesis data, such as described in Figure 3, thereby allowing for comparison of like images to more easily identify regions of interest.

[0051] Figure 6A illustrates the display of the synthesized 2D image as a scout view thumbnail image which may be provided as an overlay in a display of T_p and/or T_r images. Such a scout view may be used to guide the workflow of the medical professional during review of the tomosynthesis images. Figure 6B illustrates two scout views, showing, for example, a legacy 2D image together with a current 2D image. The ability to compare the two images may further assist the medical workflow. Although Figure 6B illustrates a legacy M_p image together with an M_s image, any two 2D images associated with differently timed acquisitions could be used, and the present invention is not limited that the particular images shown in the figures.

[0052] Figure 7 illustrates a display of two synthesized 2D images, of different views (CC and MLO). In the embodiment of Figure 7, a Computer Assisted Detection

(CAD) process has been applied to either the synthesized 2D views or alternatively to the reconstructed tomosynthesis data, providing resulting CAD marks 350. As described in the '050 application, the CAD marks resulting from processing a mammogram may be projected onto the 3D tomosynthesis image and visa versa. The present invention further envisions that the CAD marks may be similarly translated across images when using 2D synthesized images.

[0053] A variety of methods can be used to select the particular image to be displayed. For example a menu driven interface may be automatically populated with the types of images that are available for display, including both currently acquired images and a selection of available legacy images. Software allows the selection of one or more image planes, for use in image processing, or to change window/level or to change slice height, etc. The menu driven interface may be further populated with display arrangements, including overlaid, cine, inset views, etc. Alternative methods, such as drag and drop techniques can be used to position images on the screen. These sets of images can be on one monitor, or on multiple monitors or other displays.

[0054] When more than one image is displayed, it can be convenient to have the images all be displayed at the same pixel spacing, using known interpolation or extrapolation methods applied to digital images. This can facilitate image comparison. As an example, if the prior mammogram was acquired on a system using 100 micron pixel spacing, but the current mammogram was acquired on a system using 70 micron pixel spacing, the display can map the images so the pixel spacings are identical. This pixel spacing adjustment can also be used for Ms, Mp and Tr/Tp images. In a preferred embodiment, (with the exception of thumbnail scout views such as those of Figures 6A and 6B) the Ms, Mp and Tr/Tp images are displayed at the same pixel size. This is especially useful in performing overlaid or toggled image display, with the Ms, Mp and Tr/Tp images on top of each other. Thus, an object in a Tr image will appear at the

same place as in the corresponding Ms/Mp image. If the two images are not at the same pixel size, toggling between them may show a distracting change due to the difference in pixel size. Matching the pixel spacings for all images on the display is only one possibility. A capability to change the pixel spacings of any image or sets of images, such as would occur when one zoomed a region of a breast, can also be included.

[0055] Zooming can be done on any of the images on the display. For example, in a combo overlay display mode, the zoomed area will zoom both the Ms/Mp and the Tr slice images as they are toggled. In other words, no matter what image type is displayed, it will be zoomed. Window/level can be independently, or jointly, applied to any combination of images on the display. In particular, for the Tr images the window/level can be applied to just the single displayed Tr slice image, or all the Tr slice images. If there is a magnified region of an image, window/level can be selectively applied just to the magnified region or to the entire image.

[0056] According to another aspect of the invention the synthesized mammogram may be used in conjunction with a tomosynthesis image at the technologist workstation to assist in the identification of tomosynthesis slices associated with regions of interest. For example, referring now to Figure 8, a technologist or other user may place a marker (410A) or otherwise highlight regions of interest (420A, 430A) on a mammogram. The present invention automatically reflects the marker, by generating a duplicate marker at a corresponding x-y location on the tomographic image 400B as markers 410B, 420B, and 430B. As a user moves the marker to different locations within the image (for example, using a mouse to drag a cursor associated with the mark or region), the reflected mark moves similarly in the alternate image. The automatic reflection of the marker can easily be accomplished using standard graphic imaging techniques because the coordinate systems of the two images have already been

aligned for display purposes; thus there will be a one to one relationship between the x-y location of the added mark, and the x-y location on the alternate image where the mark should be reflected. The markers essentially lie on a two-dimensional plane which lies over the respective images, and remain in position as the user scrolls depthwise through the tomographic slice images. Thus the marker will remain over the tomosynthesis slices as the user scroll depth-wise through the tomosynthesis slices. Similarly, the technician may place markers on the tomosynthesis image which are reflected onto the mammogram. With such an arrangement the technician is able to quickly discern how an artifact in the tomosynthesis slice appears in a mammogram image.

[0057] FIG. 9 illustrates an overall mammography/tomography system in which the preferred but non-limiting examples discussed above can be implemented. The Figure illustrates in block diagram form an x-ray data acquisition unit 100 that includes an x-ray source 110 imaging a breast 112. An x-ray imager 116 such as a flat panel x-ray imager commercially available from the assignee of this patent specification generates projection image data that can be a mammogram Mp or a tomosynthesis projection image Tp. X-ray source 110 is mounted for movement so that images Tp can be taken at different angles. X-ray imager 116 can be stationary or it can also move, preferably in synchronism with movement of x-ray source 110. Elements 110 and 116 communicate with x-ray data acquisition control 118 that controls operations in a manner known from said earlier-filed patent specifications. X-ray image data from imager 116 is delivered to processing unit 120. Processing unit 120 comprises reconstruction software 122, which may be stored in a computer readable medium of unit 12. The reconstruction software processes x-ray image data as known from said earlier-filed patent application into Tp and Tr image data, which may be stored

in storage device 130 and displayed at image display unit 150 as disclosed in the various embodiments described above.

[0058] In particular tomosynthesis reconstruction may use any of the methods described in the "Matching Geometry" patent application (serial number 11/667,650) referenced above. The disclosed process and system generate and display tomosynthesis slice images of a patient's breast such that an object in the breast is at same or at least matching relative places in each slice image in which it is visible and, preferably, also at the same or at least matching place as in a conventional mammogram of the same breast. To achieve this, the method and system described in the "Matching Geometry" patent application obtain 2D x-ray projection data for tomosynthesis images preferably using a cone-shaped or pyramid-shaped imaging x-ray beam, and generate tomosynthesis images such that they conform to the same geometric coordinate system as a mammogram and, preferably, to the same coordinate system as a 2D projection mammogram. As a result, anatomical structures appear at geometrically matching or corresponding places in such tomosynthesis images and, preferably, in the mammogram. In one embodiment, the tomosynthesis images can be generated in a two-step computer-implemented process that first reconstructs tomosynthesis images in an initial coordinate system, such as a Cartesian coordinate system, in which objects are not or may not be at matching positions in different tomosynthesis images or in the mammogram, and then projects those images into another coordinate system, such as the coordinate system of the mammogram. In a second embodiment, the reconstruction can directly generate tomosynthesis images in a desired coordinate system, e.g., the cone beam geometry of the mammogram. According to one aspect of the invention, this direct reconstruction can further be projected onto a different coordinate system if desired, for example to modify the plane of reconstruction.

[0059] For example, FIG. 10 illustrates a front view where the long axis of the compressed breast 10 is normal to the sheet. The breast 10 is compressed between an image receptor 12, such as a flat panel digital imager, and a compression paddle 14, and is imaged with a cone-shaped or pyramid-shaped x-ray beam 16 from an x-ray source 18. Two objects are illustrated in breast 10, object #1 at slice A and object #2 at slice B. The term object is used here to refer to any structure that can be imaged in a mammogram or a tomosynthesis image, such as a lesion in the breast, and the term slice is used to refer to a layer of the breast of a finite thickness, e.g. thickness in the z-direction, that is less than the total breast thickness. For example, a slice can be a few mm thick, or thinner or thicker. Because the objects #1 and #2 are along the same x-ray trajectory 20, they appear superimposed in a mammogram. However, because x-ray trajectory 20 is not normal to the image plane of receptor 12, as is the general case with x-ray trajectories when using such cone-beam geometry, the two objects appear at different xy locations in tomosynthesis projection images for slice A and slice B. The "Matching Geometries" application describes a reconstruction and display method for tomosynthesis images that matches the coordinates of tomosynthesis images with mammograms. All relevant x-ray measurements can be obtained as respective 2D sets of pixel values (x-ray measurements for elemental picture areas) at each of several different angles of an x-ray beam relative to a breast, e.g. at several equidistant angles over a range. Other raw x-ray data acquisition techniques can be used in the alternative. After pre-processing of the type known in the mammography and breast tomosynthesis art, those pixel values can be reconstructed into a rectangular Cartesian coordinate system (30 in FIG. 11a) using known reconstruction algorithms such as filtered back projection, iterative reconstruction, maximum likelihood reconstruction, or others. As illustrated in FIG. 11a, the voxels (elemental volume elements) that are imaged as respective

pixels in the tomosynthesis slice images are aligned along lines normal to the image plane of receptor 12. The result can be conceptualized as a set of pixel values representing x-ray properties of the voxels that are in the 3D space bound by the image plane of receptor 12 at the bottom, compression paddle 14 on top, and on the sides by the boundaries of an x-ray beam 16 that impinges on receptor 12, and are uniformly spaced in xy planes. Because the x-ray beam 16 is cone-shaped, the sides of this 3D space slope at least on three sides of the beam, and the x-ray trajectories from source 18 to receptor 12 diverge in the general case. Thus, in the general case each x-ray trajectory such as trajectory 20 is non-normal to the image plane of receptor 12. Tomosynthesis image slices that match the geometry of the mammogram can be obtained by projecting each of several horizontal breast slices separately onto the image plane of the mammography images, taken along the actual x-ray trajectories included in x-ray beam, using a computer-implemented process adapted without undue experimentation to a particular x-ray data acquisition geometry by a programmer of ordinary skill in the art.

[0060] Alternatively, for a cone beam x-ray illumination, the reconstruction geometry can be a cone beam coordinate system 31 shown in FIG. 11b, where the voxels that correspond to pixels in the tomosynthesis slice images are at different xy spacings (and differ in size at least in the xy plane) in different slices and corresponding voxels of different slices are along the same (generally sloping) x-ray trajectory. For the reconstruction processing carried out by reconstruction software 122, a geometry matrix can be defined from a geometry calibration file and input projection angles appropriate to the acquisition system 11 for use in backprojection, from fits to the matrix elements determined from a geometry calibration of the acquisition system 11 and input projection angles measured by an encoder in the acquisition system 11. Image processing and filtering can be carried out on the images prior to reconstruction, using image

processing techniques known in technologies such as CT scanning and tomosynthesis. A known skin line correction can also be applied at this stage. A backprojection can then be carried out, one tomosynthesis slice at a time, using the geometry matrix as follows:

[0061] Equation 1:

$$\begin{pmatrix} u \\ v \\ s \end{pmatrix} = (M_i) \begin{pmatrix} x \\ y \\ z \\ 1 \end{pmatrix}$$

[0062] $d_x = u/s$
 $d_y = v/s$

[0063] Where u,v,z is the location of the reconstructed pixel, M_i is the 3x4 geometry matrix for projection i, (x,y,z) is the location of an image pixel, and (dx, dy) is the location on the x-ray detector element or area for the line that connects a focal spot in source 18 and the image pixel.

[0064] It is important to note that the geometry matrix (M) is not limited to a Cartesian geometry, or to the acquisition system geometry. Rather the present invention realizes that there may be advantages to reconstructing the data according to the geometry of *any* coordinate system. Figure 11c illustrates exemplary virtual cone beam geometry, where the cone beam coordinate system is derived from a hypothetical acquisition system having virtual focal spot positioning. Such a coordinate system, like that of Figure 11b, has different pixel spacing for each tomosynthesis slice. However, in such an arrangement the angle of pixel spacing close to the chest wall is increased. Other virtual coordinate systems, associated with different hypothetical acquisition system or which focus on different portions of the imaging area may be substituted readily herein within the scope of the present invention.

[0065] The above reconstruction methods use a filtered backprojection process to project data to a known geometry. However, other known methods of

reconstruction can be used to achieve the same results, including but not limited to iterative reconstruction, maximum likelihood reconstruction, or others, for example as taught in said patent application Ser. No. 10/723,486.

[0066] The tomosynthesis image slices to be reconstructed can be parallel to a "default" reference plane as suggested by Equation 1 above. Alternatively, they can be at other desired orientations, defined by a 4X4 matrix multiplication operation applied to the original 3X4 matrix M, according to:

[0067] Equation II:

$$[0068] \begin{pmatrix} u \\ v \\ s \end{pmatrix} = (M_i) \begin{pmatrix} R_{3 \times 3} & T_3 \\ O_3^T & I_1 \end{pmatrix} \begin{pmatrix} x' \\ y' \\ z' \\ 1 \end{pmatrix} \text{ where } \begin{pmatrix} x \\ y \\ z \\ 1 \end{pmatrix} = \begin{pmatrix} R_{3 \times 3} & T_3 \\ O_3^T & I_1 \end{pmatrix} \begin{pmatrix} x' \\ y' \\ z' \\ 1 \end{pmatrix}$$

[0069] For example, a preferred orientation can be an orientation in which a particular mammogram is taken. Alternatively the use of the perspective matrix allows the reconstructed image to be viewed at any orientation. For example, it may be desirable to have several sets of reconstructed data which are related to a common set of projection images, but are reconstructed using different perspectives and coordinate systems.

[0070] In summary, reconstructing tomosynthesis slice images can involve: 1.) The selection of the orientation of image slices to be reconstructed. The slice can be either parallel to the "default" reference plane as suggested by Equation I, or at another more preferred orientation, which is defined by a 4x4 matrix multiplication operation to the original 3x4 matrix M, as expressed by Equation II; and 2.) Selection of the reconstruction voxel grid in space, which can be either a Cartesian grid (FIG. 11a) or a Cone beam grid (FIG. 11b) or virtual grid (FIG. 11c).

[0071] Processing unit 120 further includes 2D synthesis software which uses one or more of the Tp and/or Tr images to synthesize a 2D image.

[0072] There are varieties of methods that can be used to synthesize a 2D image using tomosynthesis data. In a simplest form, any Tp image taken during the tomosynthesis scan may be used as 2D image. Tp images may be used individually, or alternatively a subset of Tp images or a subset of Tr slices (reconstructed using any of the methods above) may be combined, using algebraic methods (averaging, weighted averaging, statistics or other methods), maximum intensity projection, or other known means to provide the 2D image. One example of a method for synthesizing a 2D image will now be described although it should be understood that the present invention is not limited to any particular method of synthesizing a 2D image, but rather encompasses any synthesizing technique which can be used to generate a 2D image from a tomosynthesis data set.

[0073] In an exemplary embodiment, a tomo data set consists of Tp0 raw projections, Tp processed projections, and Tr reconstructed slices. The Tp processed projections have been processed as described in the '650 application to perform at least one of coordinate geometry matching and data set size reduction.

[0074] A single 'synthesized' 2D image T2d, analogous to the conventional mammography image Mp, is built from the 3D tomo data set alone. As described above, the 2D synthesized image may provide a quick overview of the breast anatomy to facilitate diagnosis and help the radiologist focus on specific regions when analyzing the 3D slices. When reviewing images on the display workstation, the image T2d may replace the Mp image that would normally be present in a combo mode procedure, or may be viewed against legacy Mp images, or displayed in a variety of other combinations.

[0075] Figure 12 is a flow diagram that illustrates exemplary steps that may be performed in a 2D synthesis process. Figure 9 assumes that methods described in the '650 application have been used to generate a set of slices Tr as in put to

the process, wherein the set of slices are represented in a Cone Beam or Cartesian coordinate system, or alternatively represented in a virtual coordinate system (associated with a virtual acquisition system). It should be understood that although the below equations describe a method using Tr images, similar processing may be performed with any subset of the Tp images.

[0076] At step 910, the Tr data set is apportioned into a slabbed set of slices Tslab. That is a number of images Tr are effectively combined, using maximum intensity projection (MIP) or averaging to generate a set of Tslab slices. Equation III below illustrates how the set Tslab is formed using MIP, while Equation IV below illustrates how the set Tslab may be formed using averaging.

[0077]

[0078] Equation III:

[0079] Let a slice in the original set be Tr [j, z] where j is the pixel index of the image and z is the slice number.

[0080] $Tslab[j,z] = MAX(Tr[j,z-Nslab/2], Tr[j,z-Nslab/2+1], \dots, Tr[j,z+Nslab/2])$

[0081] Equation IV:

[0082] $Tslab[j,z] = AVE(Tr[j,z-Nslab/2], Tr[j,z-Nslab/2+1], \dots, Tr[j,z+Nslab/2])$

[0083] At step 920, once the voxel values in the Tslab slices have been selected, the set of slices is re-projected to produce an initial image T2d0. Re-projection methods are well known in the field of image processing. A source point and image plane is chosen, on opposite sides of the image volume. Pixels are obtained by projecting the source point through the slice set to an image plane point. The pixel value is summed at each slice location by interpolating values in the original slices. Note, in the case of cone beam coordinate system reconstruction as described in the '650 application and above, the re-projection is just a sum of pixel values, with no interpolation involved, and is represented by Equation V below:

[0084] Equation V:

[0085]
$$Trep[j, z] = 1/N \sum_{z=zmin}^{zmax} Tslab[j, z]$$

[0086] Where $zmin$, $zmax$ may be chosen to exclude slices near the breast boundary, or skin. This may reduce artifacts. $N = zmax - zmin + 1$.

[0087] Step 930 performs an optional step of filtering the re-projected image to produce T2d. The filtering that is performed should be generally in the direction of the source motion in the original tomosynthesis image acquisition. Although not required, filtering may help reduce additional blur produced in the re-projection due to artifacts in the slices Tr . It is further noted that the filtering step 930 may be performed prior to the re-projection of step 920, but at a computational cost.

[0088] The advantages of using the cone beam geometry reconstructed slices as input are as follows. Interpolation at step 920 is simplified because geometric correlation was already performed in the reconstruction. Thus the final image T2d will be registered geometrically with the original set of slices Tr , as described in the '650 application. The registration would facilitate diagnosis as well as the display of CAD results on T2d, where the CAD results are derived from the 3D images Tr . The 3D CAD results may also be re-projected (or summed) as in step 2 and overlaid on T2d.

[0089] Accordingly several systems for displaying x-ray images together with 2D images that are synthesized from tomosynthesis image data have been shown and described. The synthesized images may be generated and displayed in conjunction with combination mammography/tomography acquisition stations and tomosynthesis only acquisition stations. The images may even be generated and displayed in combination with mammography only acquisition stations when legacy tomosynthesis data is available. With such an arrangement diagnostic efficiency is increased because the provision of familiar images along with the tomosynthesis data allows historical imaging expertise to be leveraged.

[0090] Having described exemplary embodiments, it can be appreciated that the examples described above are only illustrative and that other examples also are encompassed within the scope of the appended claims. It should also be clear that, as noted above, techniques from known image processing and display methods such as post-production of TV images and picture manipulation by software such as Photoshop from Adobe, can be used to implement details of the processes described above. The above specific embodiments are illustrative, and many variations can be introduced on these embodiments without departing from the spirit of the disclosure or from the scope of the appended claims. For example, elements and/or features of different illustrative embodiments may be combined with each other and/or substituted for each other within the scope of this disclosure and appended claims.

CLAIMS:

1. A method for use in a computer system comprising one or more processors performing the steps of:
 - obtaining a plurality of x-ray tomosynthesis projection images of a patient's breast;
 - generating a three-dimensional reconstruction of the patient's breast using the x-ray projection images; and
 - synthesizing a two-dimensional mammogram using only a subset of the plurality of x-ray tomosynthesis projection images.
2. The method of claim 1 wherein the step of synthesizing the two dimensional mammogram includes the step of selecting one of the x-ray tomosynthesis projection images for use as the two-dimensional mammogram.
3. The method of claim 1 wherein the step of synthesizing the two dimensional mammogram includes the step of performing at least one of filtering and combining of a subset of the plurality of x-ray tomosynthesis images.
4. The method of claim 1 including the step of displaying the synthesized mammogram together with at least a portion of the three-dimensional reconstruction.
5. The method of claim 1 wherein the synthesized mammogram and at least a portion of the three-dimensional reconstruction are displayed overlaid to enable toggling between the synthesized mammogram and the portion of the three-dimensional reconstruction.

6. The method of claim 1 including the step of providing a user interface for controlling the display of at least one of a portion of the three dimensional reconstruction, at least one of the x-ray projection images and the mammogram.
7. The method of claim 1 including the step of displaying the synthesized mammogram at a display of a tomosynthesis system in response to a selection of a mammogram view at a user interface of the tomosynthesis system.
8. The method of claim 1 including the step of retrieving a legacy mammogram from a storage device and displaying the legacy mammogram together with the synthesized mammogram on a display device of the tomosynthesis system.
9. The method of claim 1 wherein the step of synthesizing uses at least one of an algebraic method or a maximum intensity projection method.
10. The method of claim 1, including the step of filtering at least one of the x-ray tomosynthesis projection images prior to the step of synthesizing.
11. A method comprising:
 - obtaining a plurality of x-ray tomosynthesis projection images of a patient's breast;
 - reconstructing the plurality of x-ray tomosynthesis projection images into a three dimensional reconstructed image comprising a plurality of slices; and
 - synthesizing a two-dimensional mammogram using at least a subset of the three-dimensional reconstructed image; and
 - displaying the synthesized mammogram on a display device.

12. The method of claim 11 wherein the step of reconstructing the plurality of tomosynthesis projection images reconstructs the tomosynthesis projection images onto a first coordinate system to provide an initial reconstruction, wherein the first coordinate system is selected from a group including a Cartesian coordinate system, a cone beam coordinate system and a coordinate system associated with a virtual acquisition system.

13. The method of claim 11 wherein the step of reconstructing the plurality of tomosynthesis projection images includes the step projecting the initial reconstruction onto a second, different coordinate system to provide the three-dimensional reconstructed image.

14. The method of step 11 wherein the step of reconstructing includes the step of orienting said three-dimensional reconstructed tomosynthesis image to a selected plane.

15. The method of claim 11 wherein the step of synthesizing includes projecting at least one tomosynthesis slice image having a pixel spacing that differs from a pixel spacing of a mammogram onto a mammogram coordinate system.

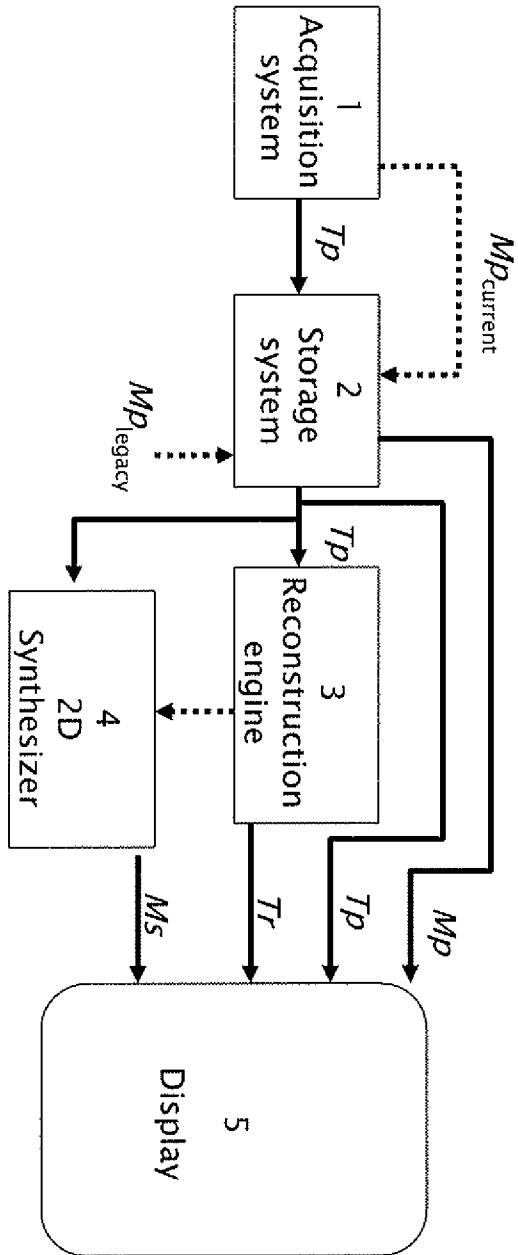

Figure 1

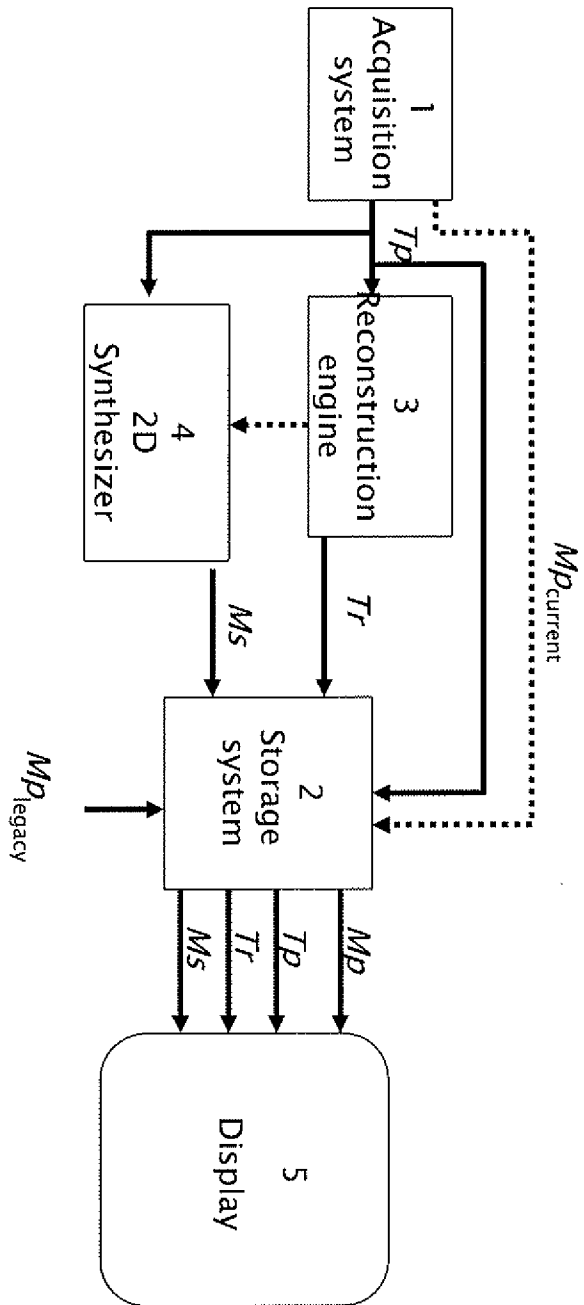

Figure 2

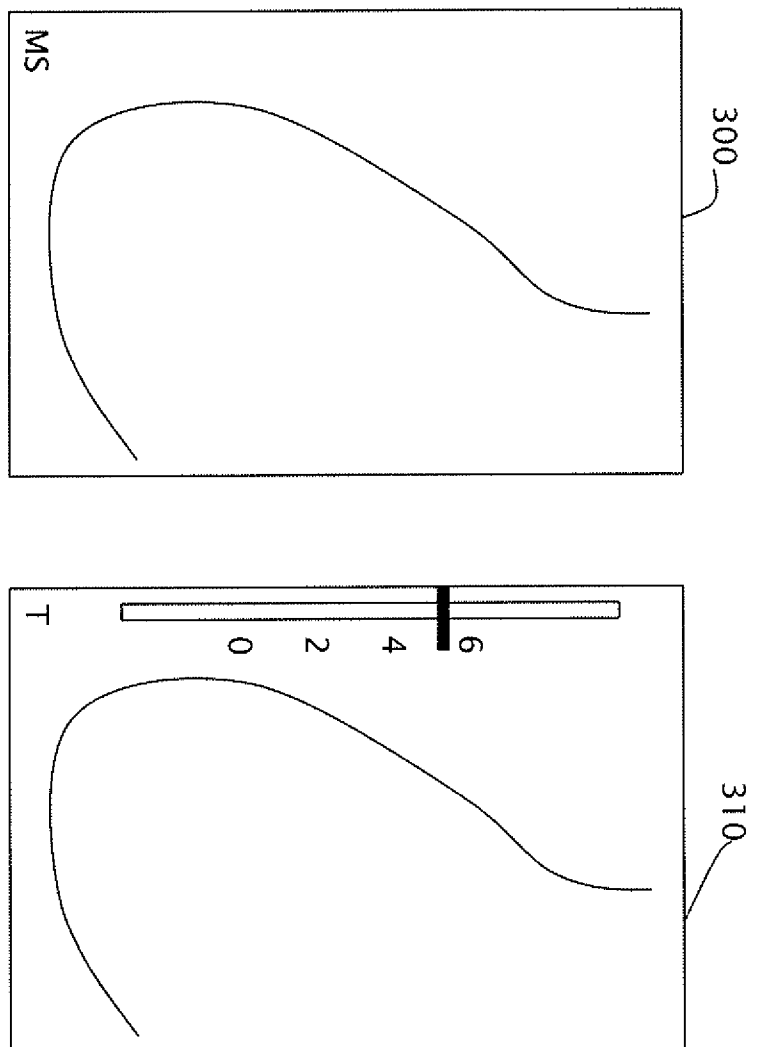

Figure 4

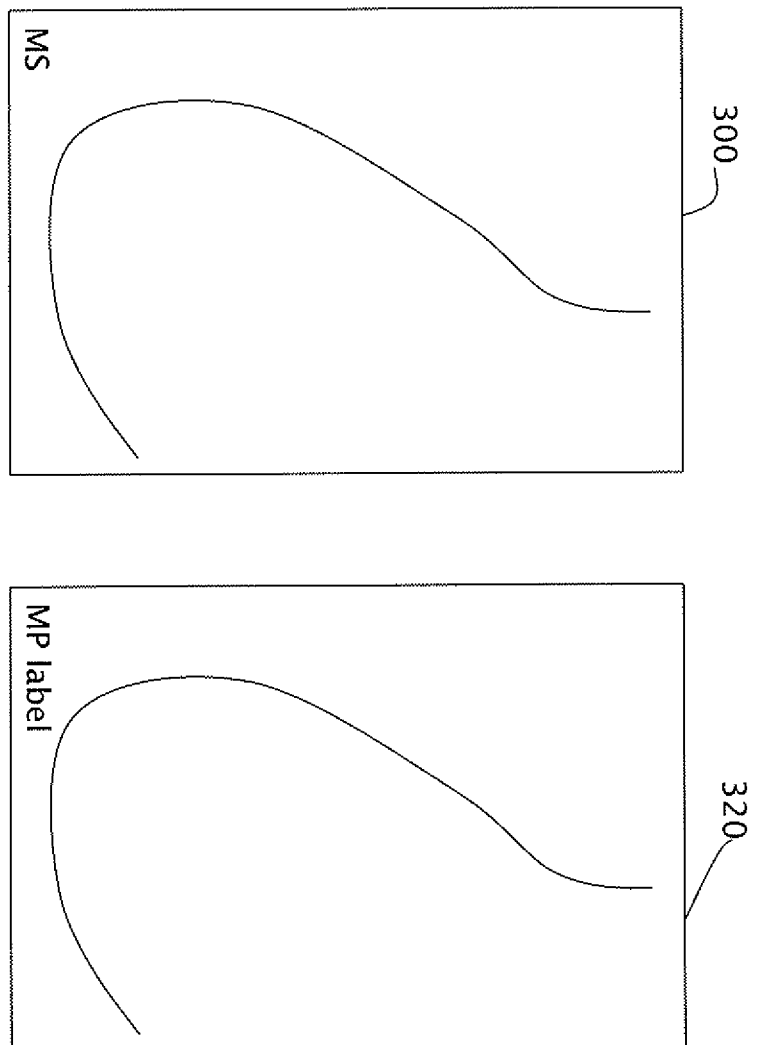

Figure 5

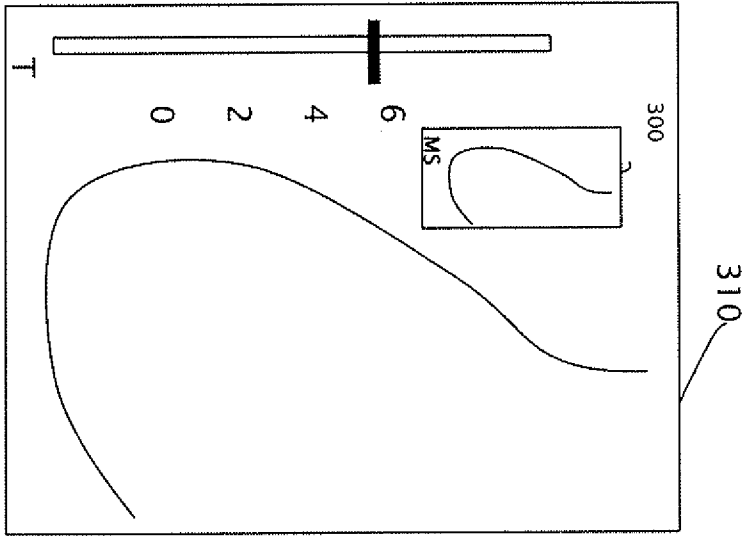

Figure 6A

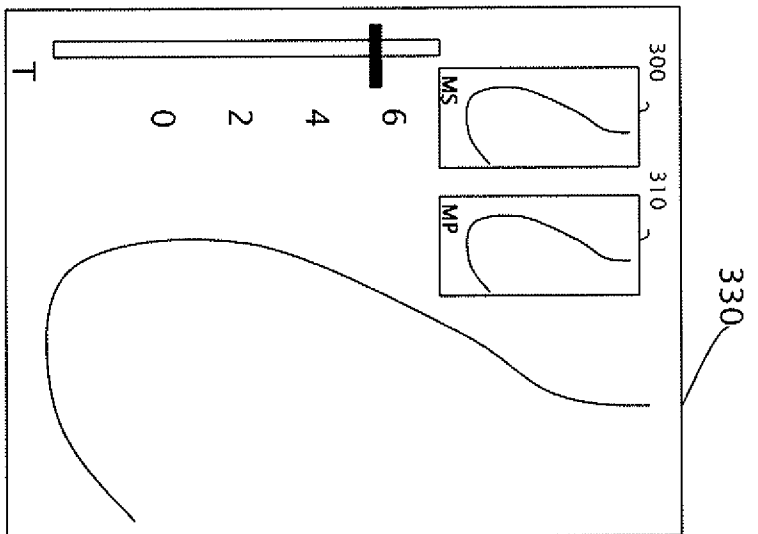

Figure 6A

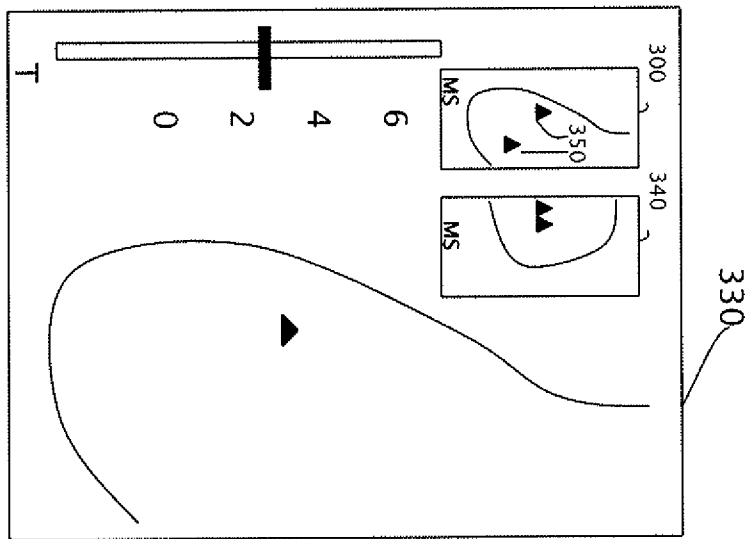

Figure 7

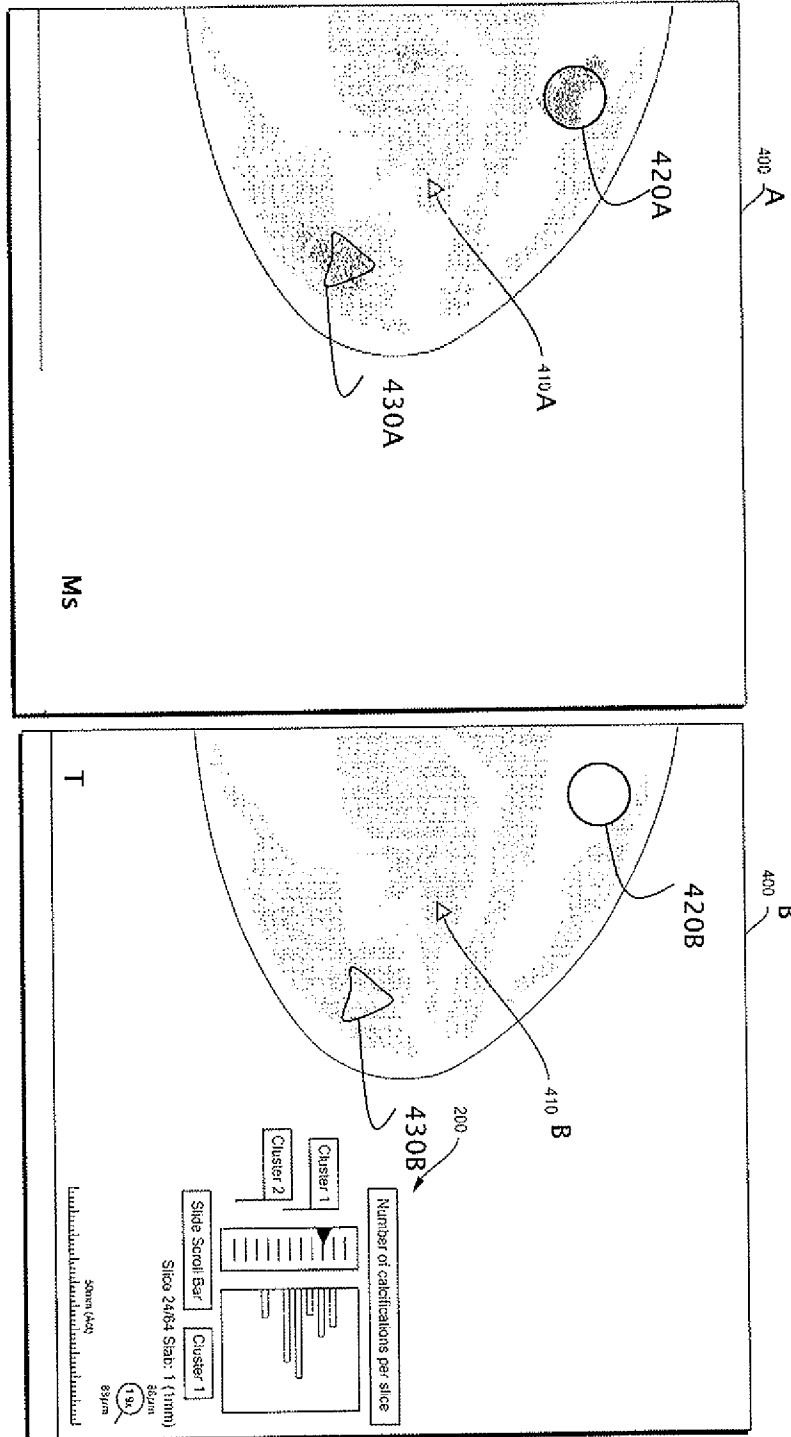

Figure 8

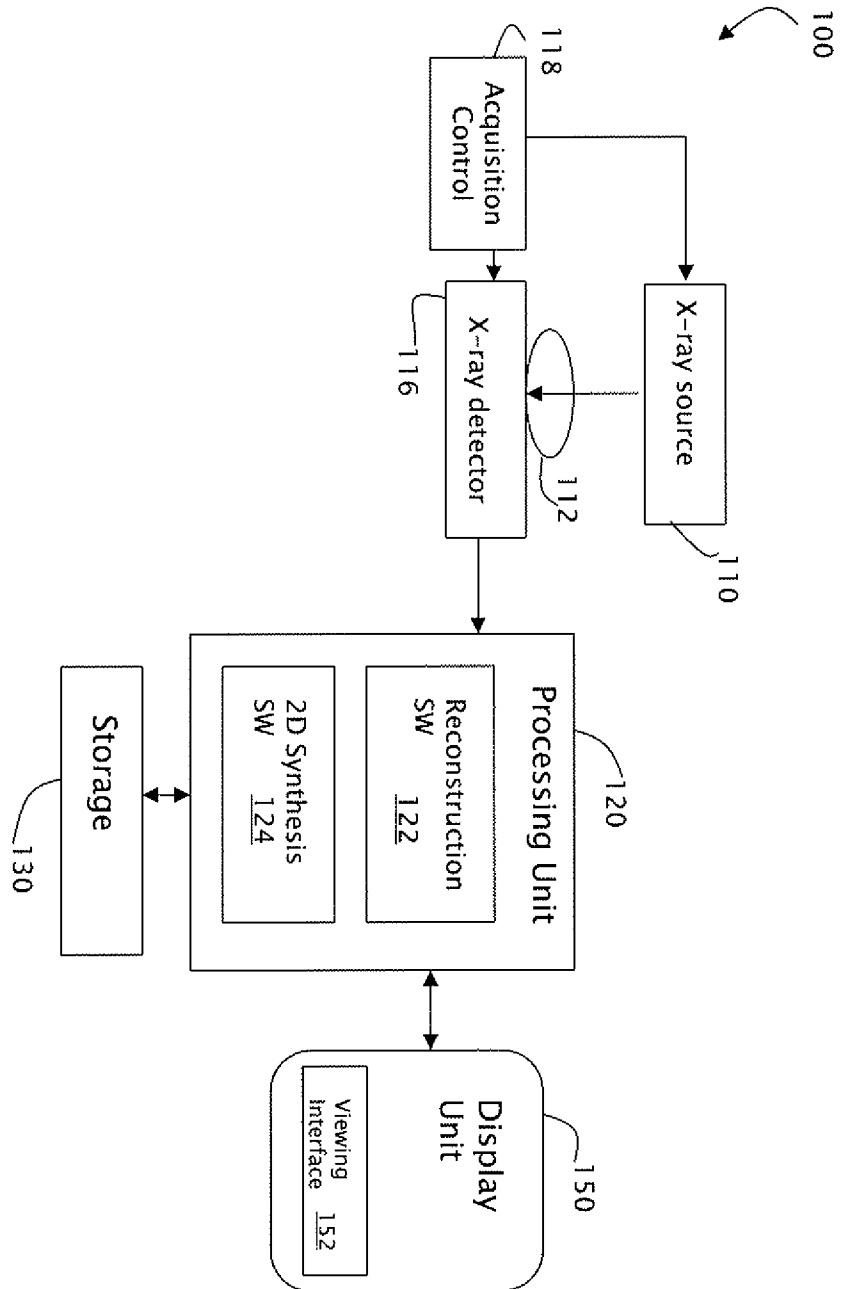

Figure 9

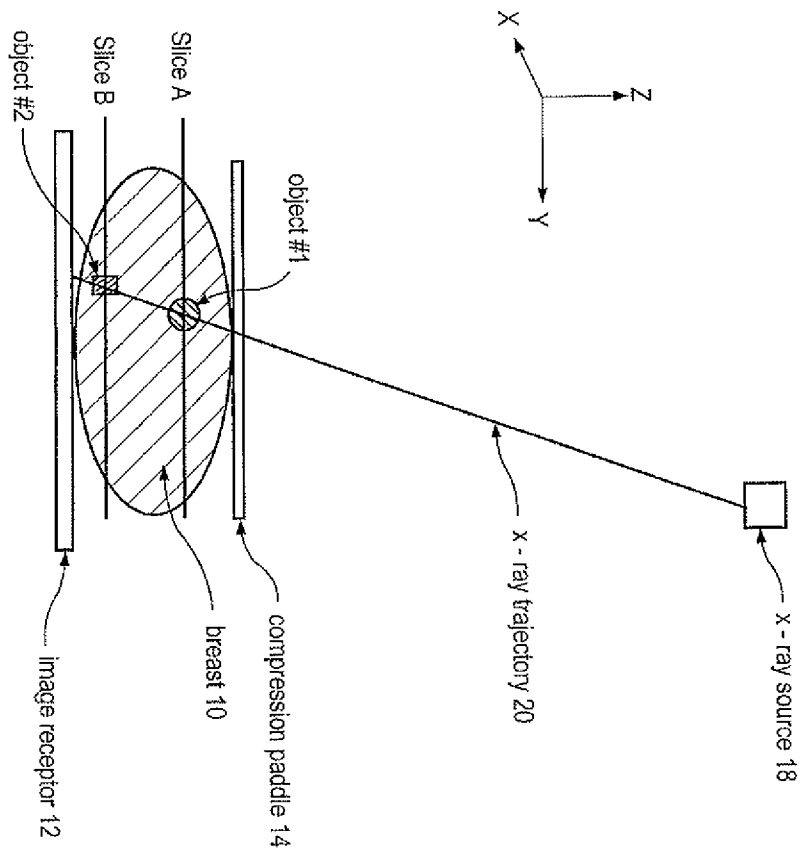

Figure 10

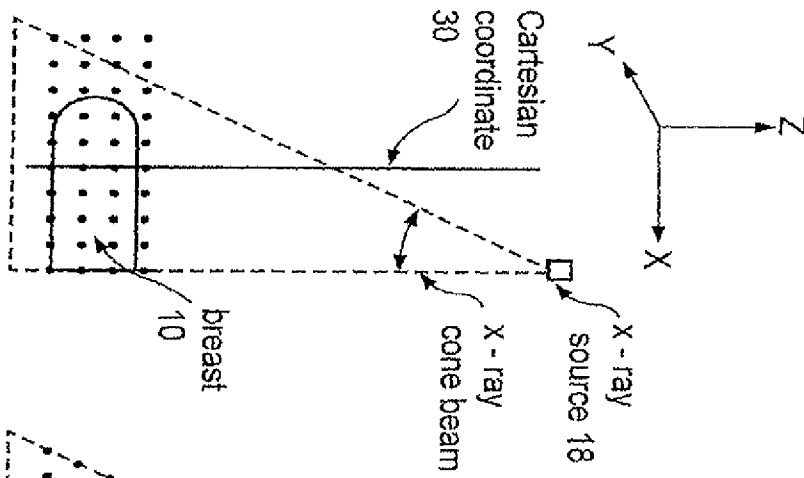

Figure 11a

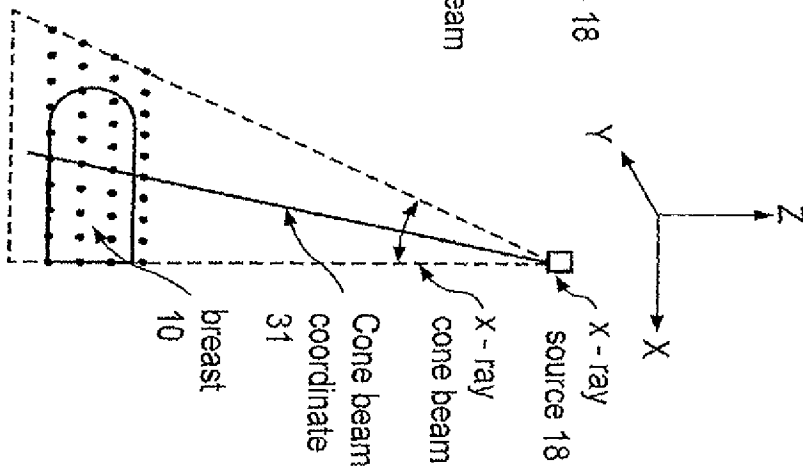

Figure 11b

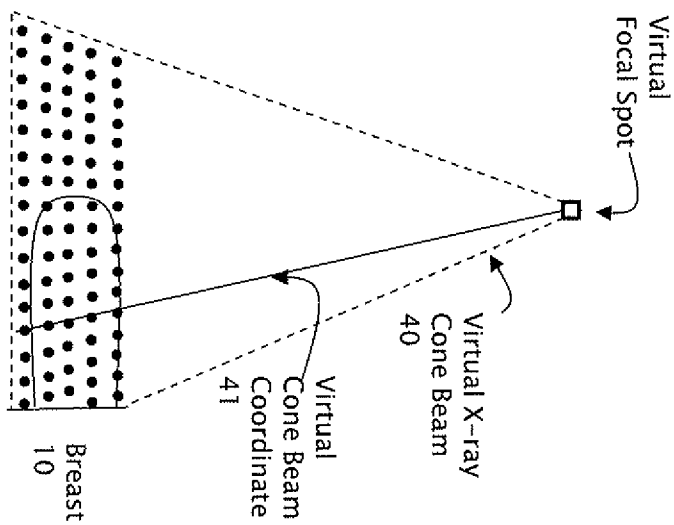

Figure 11c

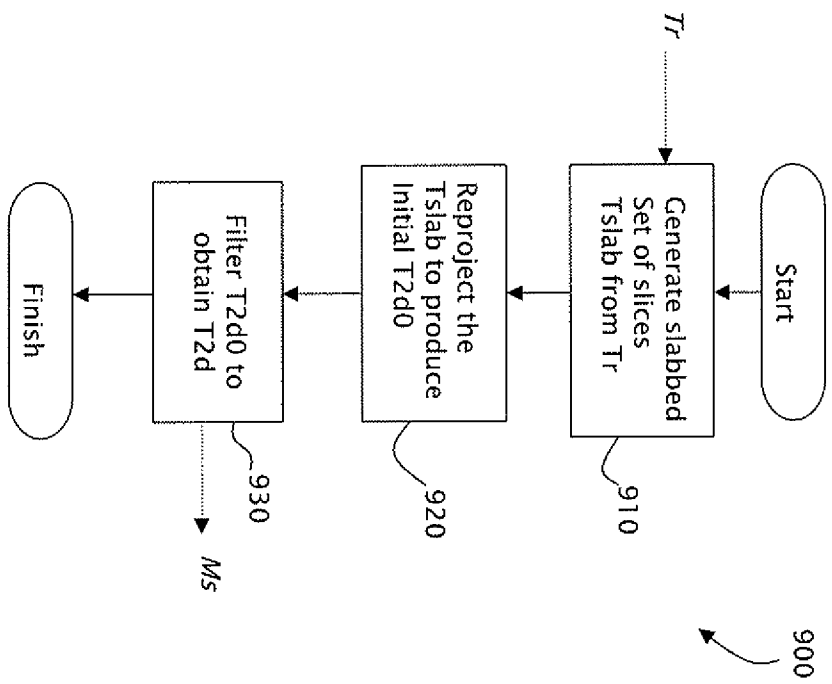

Figure 12