

C. KELLOGG. BOILER.

No. 571,595

Patented Nov. 17, 1896

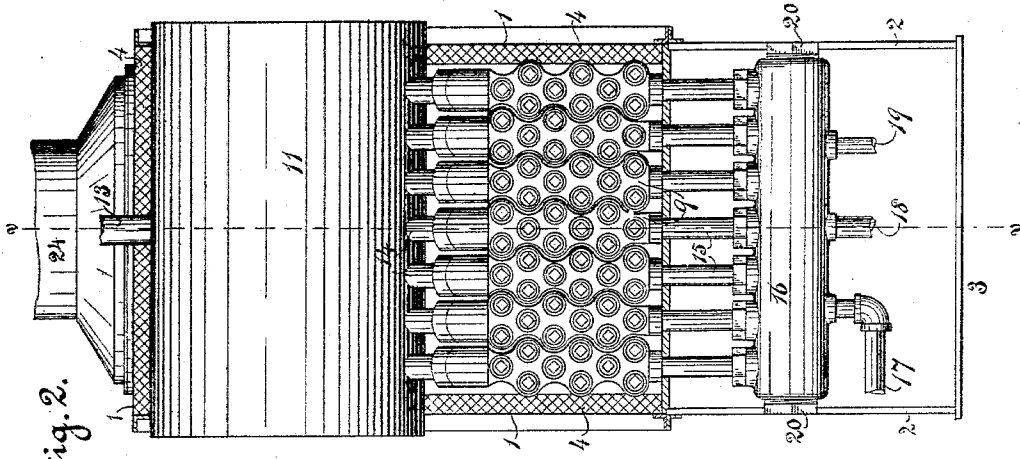

Fig. 2.

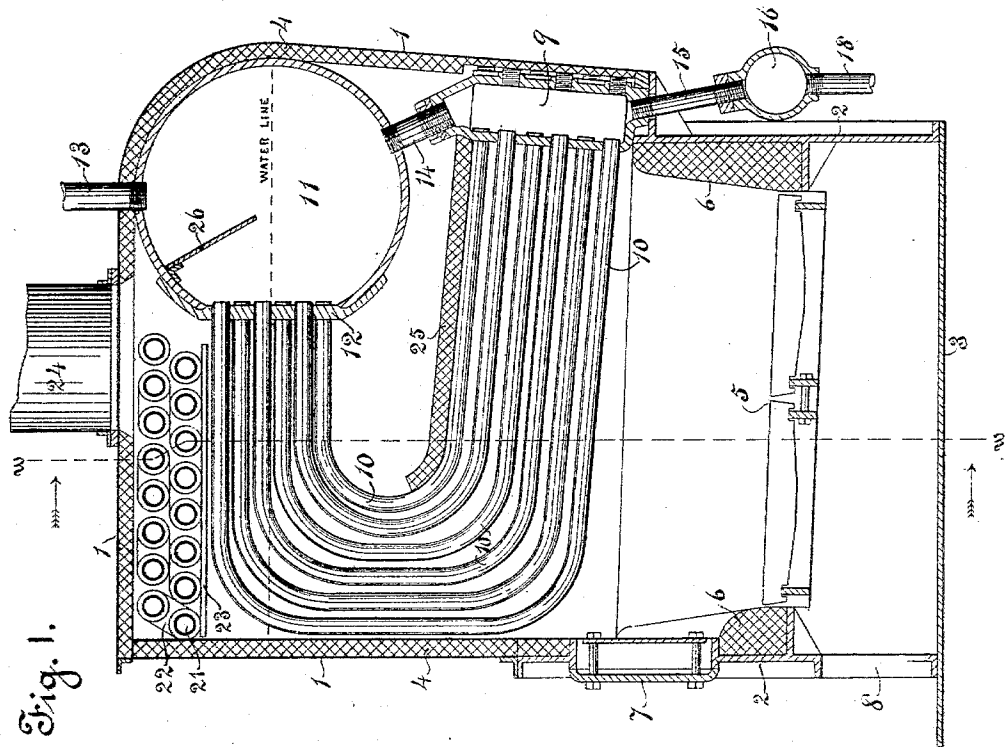

Fig. 1.

Witnesses
H. H. Mills.
A. S. Oliver

Inventor
Charles Kellogg
 by *Eugene Diven*
 Attorney

(No Model.)

C. KELLOGG.
BOILER.

No. 571,595.

Patented Nov. 17, 1896.

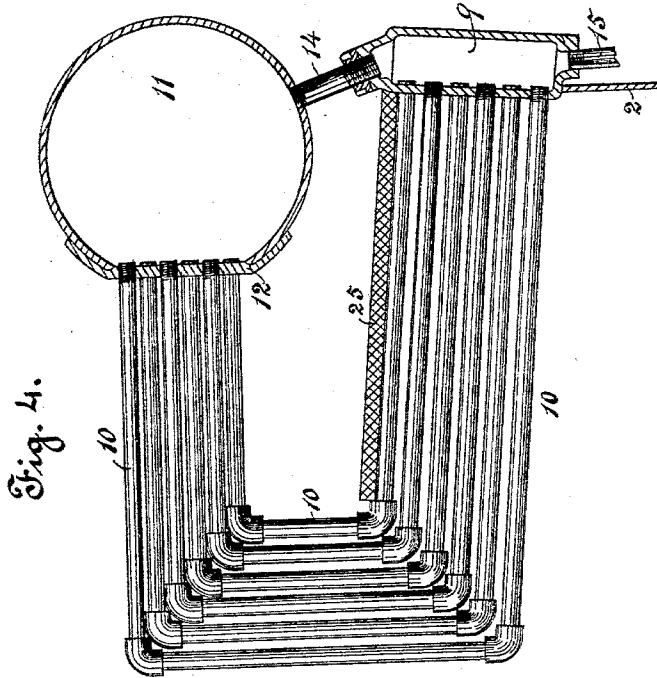

Fig. 4.

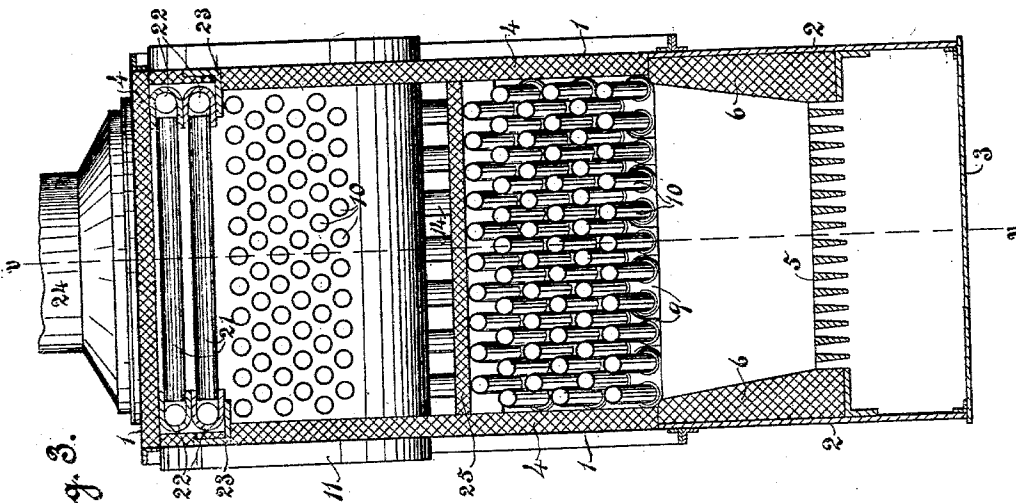

Fig. 3.

Witnesses
H. H. Mills
A. S. Diven

Inventor
Charles Kellogg
by Eugene Diven,
Attorney

C. KELLOGG.
BOILER.

No. 571,595.

Patented Nov. 17, 1896.

Fig. 5.

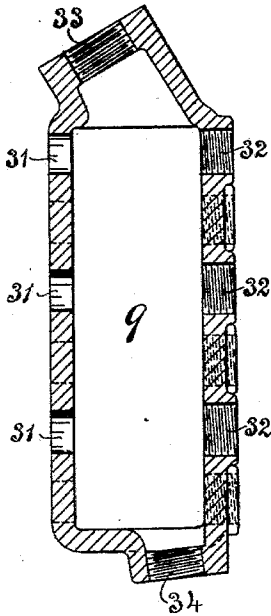

Fig. 6.

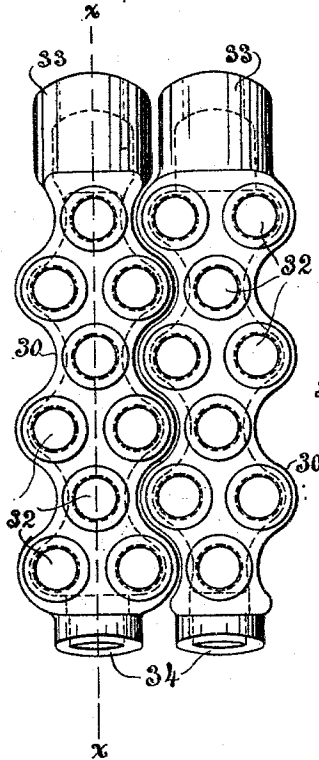
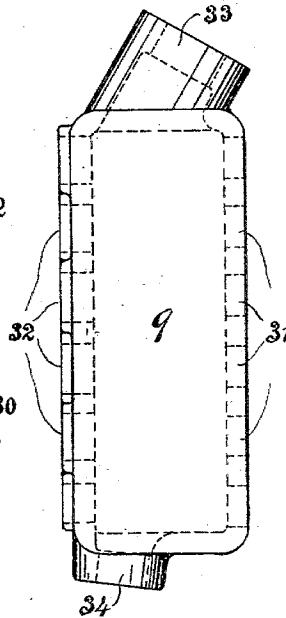

Fig. 7.



Witnesses
H. H. Mills,
A. S. Diven

Inventor
Charles Kellogg
 by *Eugene Diven*
 Attorney

(No Model.)

5 Sheets—Sheet 4.

C. KELLOGG.
BOILER.

No. 571,595.

Patented Nov. 17, 1896.

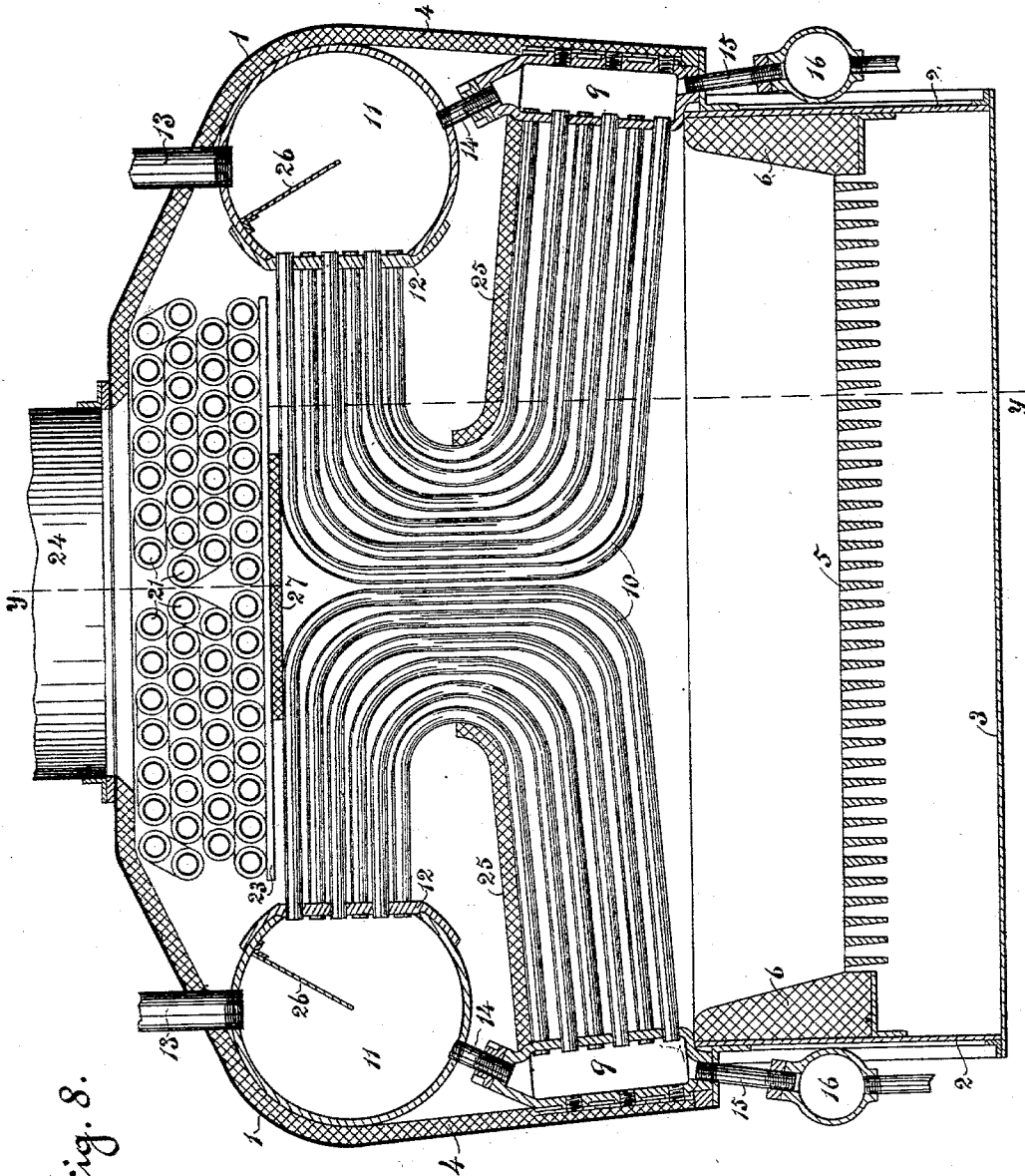

Fig. 8.

Witnesses
H. H. Mills.
U. S. Dixon

Inventor
Charles Kellogg
by Eugene Dixon
Attorney

C. KELLOGG.
BOILER.

No. 571,595.

Patented Nov. 17, 1896.

Fig. 10.

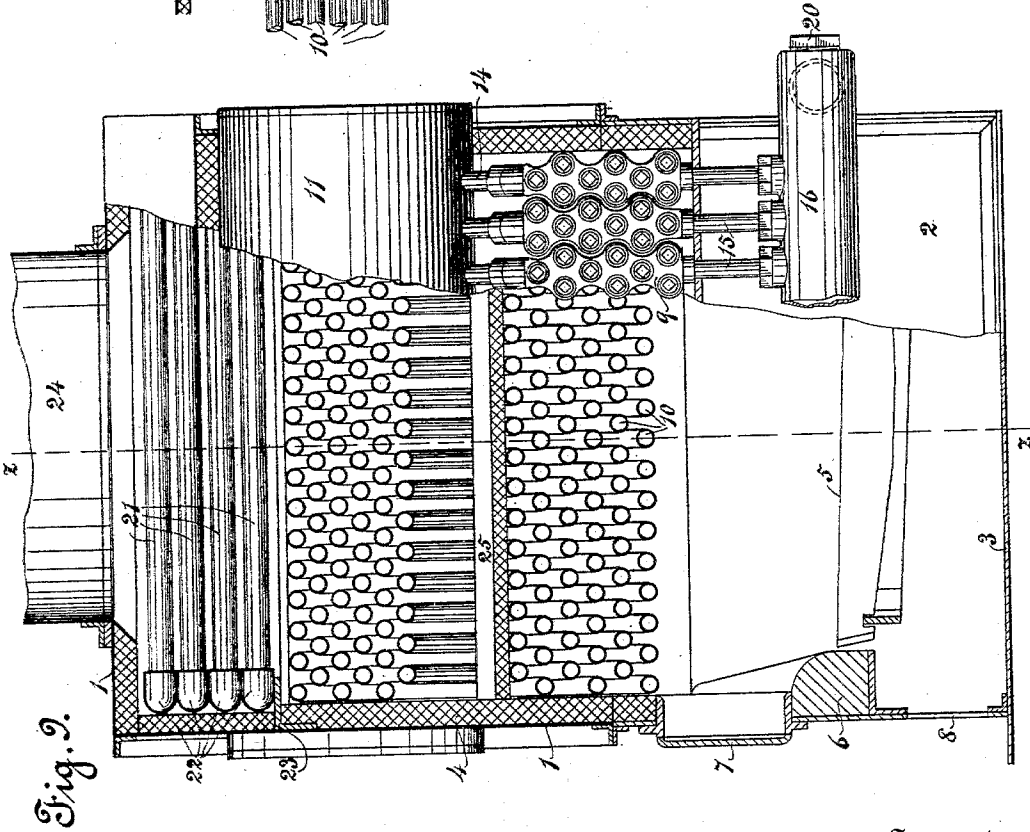
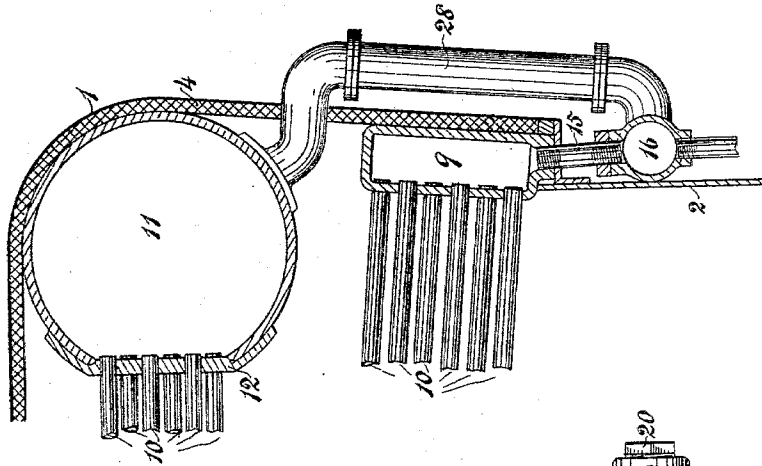

Fig. 2.

Witnesses
H. H. Mills.
A. S. Diven

Inventor
Charles Kellogg
by Eugene Diven
Attorney

UNITED STATES PATENT OFFICE.

CHARLES KELLOGG, OF ATHENS, PENNSYLVANIA.

BOILER.

SPECIFICATION forming part of Letters Patent No. 571,595, dated November 17, 1896.

Application filed July 17, 1896. Serial No. 599,557. (No model.)

To all whom it may concern:

Be it known that I, CHARLES KELLOGG, a citizen of the United States, residing at Athens, in the county of Bradford and State of Pennsylvania, have invented certain new and useful Improvements in Boilers, of which the following is a specification.

My invention relates to improvements in tubular boilers, and more especially to improvements in boilers adapted for marine purposes, the objects of my improvements being to provide in a boiler of minimum dimensions over all an arrangement of tubes and connections which will present a maximum heating-surface, give a perfect circulation of water, and insure a supply of dry steam to the steam-pipe. I attain these objects by the construction illustrated in the accompanying drawings, in which—

Figure 1 is a vertical longitudinal section on the line *vv* in Figs. 2 and 3; Fig. 2, a rear view of the boiler with the upper part of the casing removed; Fig. 3, a vertical cross-section on the line *ww* in Fig. 1, looking in the direction of the arrows; Fig. 4, a detail showing a modification in the manner of coupling up the tubes; Figs. 5, 6, and 7, details showing the construction of the headers, Fig. 5 being a section on the line *xx* in Fig. 6; Fig. 8, a vertical cross-section of a double boiler on the line *zz* in Fig. 9; Fig. 9, a vertical longitudinal section of the boiler in Fig. 8 on the line *yy*, and Fig. 10 a detail showing a modification in the return connection from the steam-drum to the headers.

Similar numerals refer to similar parts throughout the several views.

A sheathing 1, of galvanized steel, forms the upper part of the boiler-casing, the lower portion or fire-box being formed of cast-iron plates 2, all riveted together with angle-iron strips, as shown, and fastened upon a base-plate 3. The upper casing has a lining 4, of asbestos or other suitable fireproof material, and the fire-box above the grate 5 is lined with fire-brick 6.

7 is the door to the fire-box, and 8 the opening for removing the ashes.

At the rear of the boiler, above and back of the fire-box lining, upon a suitable ledge, is located a series of headers 9, of special construction, as described farther on and shown more

particularly in Figs. 5, 6, and 7. From these headers the boiler-tubes 10 issue at right angles and run forward with a slight upward inclination, due to a slight backward inclination of the headers, then upward at the front of the boiler, and finally backward in a horizontal direction to the steam-drum 11, which they enter through the vertical flat plate 12.

The steam is carried off from the steam-drum by the pipe 13. From the bottom of the steam-drum short pipes 14 lead back to the tops of the headers 9, and from the bottom of the headers pipes 15 lead to the mud-drum 16, located at the rear of the boiler outside the fire-box. The feed-pipe 17, blow-off pipe 18, and pipe 19 to the water-gage enter the bottom of the mud-drum, and plugs or caps 20 are provided at the ends of the drum, to be removed when necessary to clean it.

At the top of the boiler, in front of the steam-drum and over the tubes, is a feed-water heater composed of lengths of pipe 21 running transversely across the boiler and having their ends united by return-bends 22 to form a coil, through which water is forced from the feed-pump to the feed-pipe 17 by connections not shown. The feed-water heater is supported by the brackets 23, formed of angle-irons riveted to the boiler-casing at the sides.

The smoke-stack 24 rises from the top of the boiler midway its ends, the hood extending transversely across the boiler.

A bridge 25, of asbestos or fire-tiles, extends across the boiler above the tubes which lead from the top of the headers, reaching forward to where the tubes bend upward, its function being to throw the heat of the fire forward and cause it to ascend through the spaces around the upward bends of the tubes, and also to throw the heat away from the return-pipes 14, so that they shall receive less heat than the tubes, thus providing against overheating this portion of the boiler and insuring a perfect circulation from the steam-drum back to the headers. Since the headers are set close together and the fire-bridge fits in close against the tops of the headers, no heat can pass directly from the fire through this portion of the boiler. All the heat is driven forward around the fire-bridge and away from the headers and return-tubes 14.

A baffle-plate 26, of bronze or other suitable metal, extends across the steam-drum, in the position shown, to throw the water carried over with the steam from the upper tubes to the bottom of the drum, dry steam rising back of the baffle-plate to the steam-pipe.

It will be noticed that the steam-drum, with the exception of its heads, is inclosed within the boiler-casing, the greater portion of the drum being thus exposed to the heat of the furnace-gases. The asbestos lining protects the rear portion of the drum, where it comes against the casing, from contact with the outer air.

The headers 9 (see Figs. 5, 6, and 7) are malleable-iron or steel castings, and so formed that the tubes are all approximately equidistant one from another, and those in alternate horizontal series are in vertical planes midway between the vertical planes of the tubes in their adjacent series. To accomplish this, the sides 30 of the headers are corrugated, so that adjacent headers fit into each other, as shown in Fig. 6, the first header being narrow at the top and having one tube-opening, and the next header broad with two tube-openings, &c., each header having three vertical rows of tube-openings. Opposite the tube-openings 31 in the headers are openings 32, fitted with plugs, through which a tool may be entered for expanding the tubes when fitted in the headers. At the top of the headers are offsets 33, which slant forward and are screw-threaded to receive the return-pipes 14, and at the bottom of the headers are offsets 34, screw-threaded to receive the pipes 15, leading to the mud-drum. The openings through offsets 33 and 34 are in vertical alinement, with a straight waterway between, and this is so no matter what number of horizontal rows of tubes may be selected for any particular boiler.

The tubes, as I prefer to make them, are each of one continuous length of tubing bent into the form shown in Fig. 1 and having their ends expanded in the headers and the plate 12 of the steam-drum. The steam-drum is provided with removable heads, by removing which the tubes may be reached for expanding.

Instead of making the tubes continuous they may be cut in straight lengths and coupled together by elbows, as shown in Fig. 4. In this modification the ends of the tubes would be threaded into the headers and steam-drum instead of expanded, in which case the rear side of the headers would be made plain, without the plugged openings.

In Figs. 8 and 9 I have shown sections of a double construction of boiler within one casing. Here the headers 9 are ranged along either side of the boiler instead of at the back, as in Fig. 1. The tubes extend inwardly to the center, where they turn up and then back to the sides and enter the two steam-drums. An additional bridge 27 is provided at the center above the upper bank

of tubes to divide the ascending gases and throw them outward to either side. It will be noticed that in the double form of boiler the fire is fed in transversely to the tubes, while in the single form it is fed in longitudinally with the tubes.

In Fig. 10 is shown a modification in which the return-pipes 14 are replaced by a single large pipe 28, which leads from the bottom of the steam-drum outside the boiler-casing down to the mud-drum, so that the water circulates from the mud-drum back to the headers instead of directly to the headers, as in Fig. 1.

In operation the fire is spread upon the grate-bars 5, the gases of combustion rise, striking the bridge 25, ascend thence around the vertical bends of the tubes and are diffused about the top of the boiler through the horizontal bends of the tubes and the feed-water-heater coils and around the steam-drum, escaping finally through the stack. The water is fed in through the heater to the mud-drum, whence it rises into the headers and tubes until it reaches a level at about half the vertical diameter of the steam-drum. As the tubes become heated steam is formed therein and escapes into the steam-drum. The water in the bottom of the steam-drum, being cooler than that in the tubes, flows back to the headers through pipes 14, which are protected from the intense heat of the furnace, and a constant circulation through tubes, steam-drum, and headers sets in, the water evaporated being replaced by water fed into the headers from the mud-drum. The slight rise in the tubes over the grate starts the circulation in the right direction.

A single boiler of my construction occupying a floor-space of thirty-three inches by fifty-three inches and fifty-one inches in height would have a total heating-surface of one hundred and eighty square feet, area of grate 6.36 square feet, ratio of grate to heating-surface 1 to 28.3, weight of boiler when steaming two thousand eight hundred and thirty-five pounds, and is calculated to carry two hundred and fifty pounds steam-pressure.

I am aware that tubular boilers have been constructed prior to my invention in which corrugated headers have been used; also that it is not new to locate a feed-water heater as I have done; also that other specific features of my general arrangement are not new, and I do not claim any of these things broadly.

What I claim as my invention, and desire to secure by Letters Patent, is—

1. In a boiler, the combination of a series of vertical headers having their sides corrugated in the manner and for the purpose described, a steam-drum above the headers, staggered tubes running from the headers out over the fire-box thence upward and finally backward to the steam-drum, return connections between the steam-drum and headers, and a feed-water inlet connected with the bottom of each header.

2. In a boiler, the combination of a series of vertical headers ranged above and outside the fire-box, each header having its sides corrugated to fit against the next adjacent header in the manner and for the purpose described and the entire series of headers being slightly inclined away from the fire-box, a steam-drum above the headers, staggered tubes issuing at right angles from the headers and running out over the fire-box, with a slight upward inclination according to the inclination of the headers, thence upward and finally backward to the steam-drum, short return connections between the bottom of the steam-drum and the tops of the headers, a mud-drum below the headers, and connections between the mud-drum and the bottoms of the headers.

3. In a boiler, the combination of a series of vertical headers ranged along a ledge outside the fire-box wall, each header having its sides corrugated to fit against the next adjacent header in the manner and for the purpose described and the entire series of headers being slightly inclined away from the fire-box, a steam-drum above the headers, staggered tubes issuing at right angles from the headers and running out over the fire-box, thence upward and finally backward horizontally to the steam-drum, a fire-bridge fitted closely to the top of the series of headers and extending out over the tubes to where they

bend upward, short return connections between the bottom of the steam-drum and the tops of the headers above the fire-bridge, a mud-drum below the headers, and connections between the mud-drum and the bottoms of the headers.

4. In a boiler, a fire-box, a series of vertical headers fitted together as described and ranged along a ledge outside of and above the fire-box lining with a slight outward incline, a steam-drum above the headers, staggered tubes issuing at right angles from the headers and running out over the fire-box, thence upward and finally backward to the steam-drum, short return-tubes from the bottom of the steam-drum to the tops of the headers, a fire-bridge extending from the top of the headers out over the tubes in the manner described, and feed-water-heater pipes above the upper tubes, the above parts within one inclosing shell, and a mud-drum outside the shell beneath the headers, a connection between mud-drum and heater-pipes, and connecting-pipes between the mud-drum and the bottoms of the headers, all arranged and combined substantially as shown and described.

In testimony whereof I have affixed my signature in presence of two witnesses.

CHAS. KELLOGG.

Witnesses:

EDWARD H. BOSTWICK,
GREGG PUFF.