

(19) World Intellectual Property Organization
International Bureau



(43) International Publication Date
28 April 2011 (28.04.2011)

(10) International Publication Number
WO 2011/048267 A1

(51) International Patent Classification:
G01S 13/75 (2006.01) *G01S 5/02* (2010.01)
A01K 11/00 (2006.01)

FI-02044 Vtt (FI). **VARPULA, Timo** [FI/FI]; c/o VTT, P.O. Box, FI-02044 Vtt (FI).

(21) International Application Number:
PCT/FI2010/050814

(74) Agent: **SEPPO LAINE OY**; Itämerenkatu 3 B, FI-00180 Helsinki (FI).

(22) International Filing Date:
19 October 2010 (19.10.2010)

(81) Designated States (unless otherwise indicated, for every kind of national protection available): AE, AG, AL, AM, AO, AT, AU, AZ, BA, BB, BG, BH, BR, BW, BY, BZ, CA, CH, CL, CN, CO, CR, CU, CZ, DE, DK, DM, DO, DZ, EC, EE, EG, ES, FI, GB, GD, GE, GH, GM, GT, HN, HR, HU, ID, IL, IN, IS, JP, KE, KG, KM, KN, KP, KR, KZ, LA, LC, LK, LR, LS, LT, LU, LY, MA, MD, ME, MG, MK, MN, MW, MX, MY, MZ, NA, NG, NI, NO, NZ, OM, PE, PG, PH, PL, PT, RO, RS, RU, SC, SD, SE, SG, SK, SL, SM, ST, SV, SY, TH, TJ, TM, TN, TR, TT, TZ, UA, UG, US, UZ, VC, VN, ZA, ZM, ZW.

(25) Filing Language: English

(26) Publication Language: English

(30) Priority Data:
20096076 20 October 2009 (20.10.2009) FI

(71) Applicant (for all designated States except US): **VALTION TEKILLINEN TUTKIMUSKESKUS** [FI/FI]; Vuorimiehentie 3, FI-02150 Espoo (FI).

(72) Inventors; and

(75) Inventors/Applicants (for US only): **VIIKARI, Ville** [FI/FI]; c/o VTT, P.O. Box 1000, FI-02044 Vtt (FI). **SEPPÄ, Heikki** [FI/FI]; c/o VTT, P.O. Box 1000, FI-02044 Vtt (FI). **NUMMILA, Kaj** [FI/FI]; c/o VTT, P.O. Box 1000,

(84) Designated States (unless otherwise indicated, for every kind of regional protection available): ARIPO (BW, GH, GM, KE, LR, LS, MW, MZ, NA, SD, SL, SZ, TZ, UG, ZM, ZW), Eurasian (AM, AZ, BY, KG, KZ, MD, RU, TJ, TM), European (AL, AT, BE, BG, CH, CY, CZ, DE, DK, EE, ES, FI, FR, GB, GR, HR, HU, IE, IS, IT, LT, LU,

[Continued on next page]

(54) Title: A METHOD AND SYSTEM FOR OBJECT LOCALIZATION

(57) Abstract: This document describes a method and system for object localization. In accordance with the method an object (1) is illuminated by at least one first type of signal, and response of the signal is detected. In accordance with the invention the object (1) equipped with a transponder (2, 3) backscattering the first type of signal, the transponder (2, 3) is illuminated also by a second type of signal affecting to the backscattering frequency of the transponder (2, 3), and the backscattered signal from the transponder (2, 3) is detected in order to localize the object.

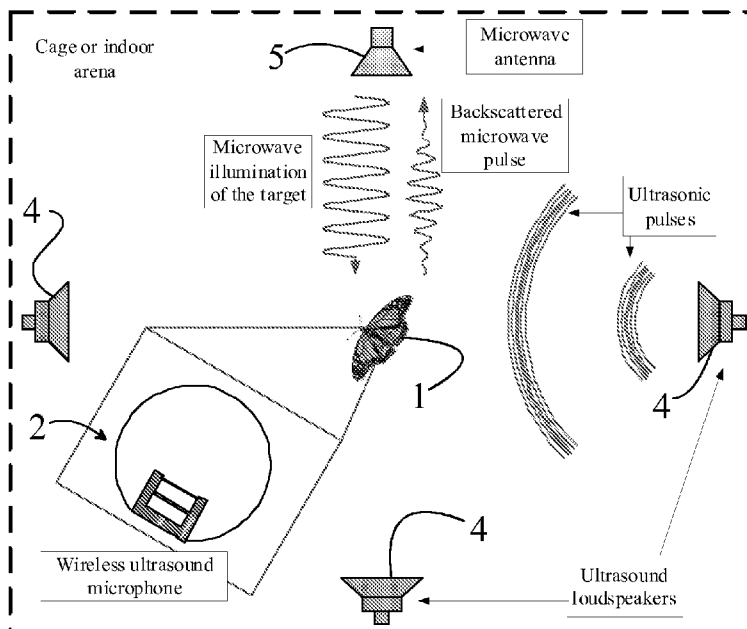

Fig. 1

WO 2011/048267 A1

LV, MC, MK, MT, NL, NO, PL, PT, RO, RS, SE, SI, SK,
SM, TR), OAPI (BF, BJ, CF, CG, CI, CM, GA, GN, GQ,
GW, ML, MR, NE, SN, TD, TG).

— before the expiration of the time limit for amending the
claims and to be republished in the event of receipt of
amendments (Rule 48.2(h))

Published:

— with international search report (Art. 21(3))

A method and system for object localization

Technical Field

The present invention relates generally to object localization and tracking.

Especially the invention relates to localization and tracking of small objects like insects.

5

Background Art

Harmonic radars are used for insect localization and tracking.

The traditional harmonic radar is not found suitable for insect tracking indoors due to the high transmit power required, mechanical scanning and limited accuracy.

10 Also RFID-technology is used for insect localization and tracking. This technology requires active tags and these are heavy and therefore not suitable for small insects.

With passive RFID tags the problem is short reading distance.

15 Accurate tracking of insect movements in real time is an important tool for scientist studying the behaviour of different species. It has been previously developed a tracking system based on UHF RFID technology.

20 Several remote sensing and telemetric insect tracking techniques have been developed for demands of biological and agricultural studies. Remote sensing techniques do not require any physical interaction with the target whereas the insect is equipped with a transponder in telemetric techniques. A review of the techniques can be found in [1].

25 The remote sensing techniques used include for example radar, video graphic and other optical techniques, X-ray imaging, and passive and active acoustical techniques. Due to heavy cluttering of radar signal from ground and vegetation, the radar can only be used to track flying insects or insect swarms.

Optical remote sensing techniques are typically based on video camera and pattern recognition software that automatically identifies the target and calculates its location. Three-dimensional tracking necessitates a 3D ranging video camera or stereo vision camera. In addition to visible wavelengths video graphic techniques are also realized at
5 infrared and thermal wavelengths, which provide night vision. Drawbacks of video graphic techniques are relatively small observation volume, unreliable pattern (and thus insect) detection, and technical challenges with ranging and stereo vision cameras.

Insect movement has also been monitored with photo detectors. The simplest systems
10 illuminate a certain volume and measure either transmitted or scattered light, which changes in the presence of an insect. A more sophisticated technique is able to detect insect wing beat from the scattered light.

Acoustic techniques can be divided into active and passive ones. Active techniques use
15 sodar (SOund Detection And Ranging), which shares the operation principle of radar but utilizes acoustic waves instead of electromagnetic waves. Sodars can only detect flying or moving insects. Passive acoustic tracking techniques record the sound produced by the tracked insect with spatially distributed microphones and solves for the location of insect by correlating the sound recorded in different locations.

20 Remote sensing techniques do not require physical contact to the insect and they do not therefore affect the insect behaviour. However, as compared to telemetric techniques remote sensing ones usually suffer from short detection range and unreliable target identification.

25 Telemetric techniques include radio frequency identification (RFID) and harmonic radar. In RFID, the tracked insects are equipped with a passive RFID tag or active transponder. Passive tags are smaller than the active ones but provide shorter range and lower tracking accuracy. An advantage of the RFID tracking principle over almost all
30 other tracking techniques is that it can be used to track and identify multiple targets simultaneously.

The harmonic radar concept is based on harmonic radar and a transponder that generates radar reflections at a harmonic frequency when illuminated by a radar signal. An advantage of harmonic radar over conventional radar is that it is able to track small radar targets that are close to cluttering objects, such as ground or vegetation.

5

Disclosure of Invention

Therefore, it is an object of the present invention to provide a new method and device for object localization and tracking.

The invention is based using typically light weight transponders based on ultrasound or light detection and microwave backscattering positioned on the objects. The transponders attached to the objects are illuminated by microwaves and either by ultrasound or light and the backscattered microwave signal is detected.

The technique in accordance with the invention utilizes a wireless ultrasound microphone that is used as a microwave transponder. Ultrasound pulses are used to measure the distance from the target to several spatially diverse ultrasound loudspeakers.

Also photodetector with suitable antenna may be used as a transponder.

More specifically, the method according to the invention is characterized by what is stated in the characterizing portion of Claim 1.

For its part, the system according to the invention is characterized by what is stated in claims 10.

For its part, the use according to the invention is characterized by what is stated in claims 18.

Considerable advantages are gained with the aid of the invention.

30

As compared to the existing harmonic radar and RFID-based insect tracking methods, both techniques could provide superior performance for insect tracking indoor or outdoor cages.

5 The invention provides precise (millimeters accuracy) insect localization in indoor arenas and cages, and this can be implemented with a relatively simple system. The invention also provides lightweight transponders.

The invention has also several other embodiments providing associated advantages.

Brief Description of Drawings

10 For a more complete understanding of the present invention and the advantages thereof, the invention is now described with the aid of the examples and with reference to the following drawings, in which:

Figure 1 presents a situation where insects are equipped with wireless ultrasound microphones in accordance with the invention which are used for tracking.

15 Figure 2 presents a schematic layout of typical capacitive MEMS microphone. The electrical equivalent circuit of the microphone can be expressed as a variable capacitor (gray).;

Figure 3 presents principle of the mechanically matched ultrasound microphone.

20 Figure 4 presents a schematic layout of the wireless ultrasound microphone (left) and its electrical equivalent circuit (right).;

Figure 5a presents as graph estimated microwave conversion efficiency of the ultrasound transponder as a function of the acoustical distance.

Figure 5b presents as graph estimated microwave detection range of the ultrasound transponder as a function of the acoustical distance.

Figure 6a presents schematically tracking principle in accordance with the invention, which is based on continuously scanning laser and photo diode transponder. The laser signal can be continuous (left figure) or pulsed (right figure).

5 Figure 6b presents schematically tracking principle in accordance with the invention, which is based on pulsed scanning laser and photo diode transponder.

Figure 7 presents schematic layout of the photo diode based microwave transponder (top) and its equivalent electrical circuit (bottom) in accordance with the invention.

Figure 8 presents graphically relative change in the junction capacitance as a function of the irradiance in accordance with the invention.

10 Figure 9 presents graphically microwave detection range of photo diode based transponder at different background irradiance levels in accordance with the invention.

Figure 10 presents graphically the measured (marker) and calculated (line) impedance of the photo diode at 1.5 GHz as a function of irradiance in accordance with the invention.

15 Figure 11 presents a photograph of the photo-activated microwave transponder in accordance with the invention.

Figure 12 presents graphically measured modulated radar cross section (RCS) of the transponder. The curves are for different irradiance levels.

Best Mode for Carrying Out the Invention

20 In the following, the theory and examples in accordance with the invention are discussed more thoroughly.

Combined Ultrasound and Microwave Tracking

25 This Section considers an insect tracking technique that is based on a microwave transponder that is activated with ultrasound. The applicant of this application has

developed ultrasound MEMS devices and has several inventions that could be useful in implementing the described system.

Tracking Principle

The tracking concept is presented in Figure 1. The tracked insects 1 are equipped with tiny ultrasound microphones 2 which are used to measure the travelling time of an ultrasonic pulse from a loudspeaker 4 to the microphone 2. The physical travelling distance of the ultrasonic pulse is related to the travelling time and the known acoustical velocity in air. The target 2 is located by measuring its distance from three different loudspeakers 4 at known locations. The target (tag) is simultaneously illuminated with microwave radiation which is modulated in the tag by illuminating the tag also by the ultrasound signal. The modulated microwave signal is reflected back to the microwave antenna 5. Since the microwave propagates at the speed of light which is many orders of magnitude larger than that of ultrasound, the arrival time of the modulated microwave signal can be used to calculate the distance of the target from the known position of the loudspeaker. The loudspeakers 4 can be identified by using different modulation.

Ultrasound Microphone Element

The wireless ultrasound microphone element 2 could be similar to the existing capacitive MEMS microphones, which are widely used for example in mobile phones. A schematic layout of a capacitive MEMS microphone is depicted in Fig. 2.

The MEMS microphone consists of a vibrating membrane supported by solid walls and backed by a cavity. The membrane is electrically conductive and it forms one electrode of the parallel plate capacitor. The other electrode of the capacitor is fixed and it is on the bottom of the cavity. The sound pressure displaces the membrane and changes its capacitance.

A drawback with the capacitive MEMS microphones is that the acoustic wave does not couple effectively to the vibrating membrane. The coupling could be improved by using a mechanical matching technique that is based on using two or more cavities instead of one. An example of a matched ultrasound microphone is depicted in Fig. 3.

The upper cavity is filled with medium-density gas, such that the sound pressure causes relatively large amplitude to the vibrating membrane. The upper oscillating membrane

causes an ultrasound oscillation in the upper cavity. This oscillation then actuates the lower membrane. The lower cavity is filled with a dense gas and the amplitude of the lower membrane is smaller than that of the upper one. This structure improves the ultrasonic coupling to the microphone at the expense of the microphone bandwidth.

- 5 We assume that a micro machined ultrasound microphone similar to that presented in Figure 2 could be as small as 1 by 1 by 1 mm and could weigh less than 2 mg.

Theoretical Electro-Acoustic Response of the Wireless Microphone

Dynamic Response of the Membrane

The dynamic response of the ultrasound microphone membrane is given as

10
$$m \frac{d^2}{dt^2} x + \eta \frac{d}{dt} x + kx = F, \quad (3.1)$$

where m is the effective mass of the cantilever, x is the cantilever displacement, η is the damping coefficient, k is the effective spring constant and F is the external force affecting the cantilever. When the membrane is actuated at its mechanical resonance frequency, the amplitude of the vibration is given as

15
$$\hat{x} = \frac{\hat{F}_\omega Q_m}{k} = \frac{\hat{F}_\omega Q_m}{\omega_m^2 m}, \quad (3.2)$$

where \hat{F}_ω is the amplitude of the harmonic force, $Q_m = \omega_m m / \eta$ is the mechanical quality factor of the resonating membrane, and ω_m is the mechanical resonance frequency of the membrane. The force due to acoustical pressure is given as $F = pA$, where p is the acoustical pressure and A is the effective area of the membrane.

- 20 Substituting this into (3.2) gives

$$\hat{x} = \frac{\hat{p}A Q_m}{\omega_m^2 m}. \quad (3.3)$$

The peak sound pressure at a distance r_{ac} from the acoustic source is given as

$$\hat{p} = \sqrt{\frac{P_{ac} Z_{ac}}{2\pi r_{ac}^2}}, \quad (3.4)$$

where P_{ac} is the acoustic power of the source and the acoustic impedance of air is $Z_{ac} = c_{ac} \rho_{air}$, where $c_{ac} \approx 330$ m/s is the speed of sound and ρ_{air} is the density of air.

Electromagnetic Modulation Efficiency

- 5 The wireless ultrasound sensor consists of an antenna that is electrically matched to the sensor element. A schematic layout of the wireless sensor with its equivalent electrical circuit is shown in Figure 4.

The equivalent capacitance of the ultrasound microphone is (assuming a parallel plate capacitor and small displacement)

$$10 \quad C = \epsilon_0 \frac{A}{g_0 + x} \approx C_0 \left(1 - \frac{x}{g_0}\right), \quad (3.5)$$

- where ϵ_0 is the permittivity of vacuum, A is the capacitor surface area, g_0 is the initial gap (and C_0 is the initial capacitance), and x is the displacement of the membrane. The wireless sensor is illuminated with a microwave signal and the antenna receives a power $P_{r,transp}$ producing a peak voltage of $\hat{V}_r = 2\sqrt{2P_{r,transp}R_a}$, where R_a is the resistance of
 15 the antenna. Assume that the ultrasound actuates the membrane that oscillates as $x(t) = \hat{x} \sin \omega_{ac} t$, where \hat{x} is the peak amplitude and ω_{ac} is the angular frequency of the ultrasound. Assuming conjugate matching between the antenna and the microphone ($R_a = R_m$ and $\omega_{rf} L = 1/(\omega_{rf} C_0)$), the modulated voltage over the antenna resistance, that is the radiated voltage, is

$$20 \quad V_{mod} \approx 2\sqrt{2P_{r,transp}R_a} \frac{\hat{x}}{g_0 R_a \omega_{rf} C_0} \sin[(\omega_{rf} - \omega_{ac})t]. \quad (3.6)$$

The corresponding power is

$$P_{mod} = \frac{\hat{V}_{mod}^2}{2R_a} = \frac{4P_{r,transp} \hat{x}^2}{g_0^2 R_a^2 \omega_{rf}^2 C_0^2}. \quad (3.7)$$

The ratio between the modulated and the received power, that is, the conversion efficiency is

$$E = \frac{P_{\text{mod}}}{P_{r,\text{transp}}} = \frac{4\hat{x}^2}{g_0^2 R_a^2 \omega_{rf}^2 C_0^2}. \quad (3.8)$$

Substituting (3.4) and (3.7) into (3.8) gives

$$5 \quad E = \frac{4A^2 Q_m^2 P_{ac} Z_{ac}}{2\pi r_{ac}^2 g_0^2 R_a^2 \omega_{rf}^2 C_0^2 \omega_{ac}^4 m^2} = \frac{2Q_m^2 P_{ac} Z_{ac}}{\pi r_{ac}^2 \epsilon_0^2 R_a^2 \omega_{rf}^2 \omega_{ac}^4 m^2}. \quad (3.9)$$

Electromagnetic Detection Distance

The transponder is continuously illuminated electromagnetically by the reader device. The received power by the transponder is given as

$$P_{r,\text{transp}} = P_{t,\text{reader}} G_{\text{reader}} G_{\text{transp}} \left(\frac{\lambda_{rf}}{4\pi r_{rf}} \right)^2, \quad (3.10)$$

10 where $P_{t,\text{reader}}$ is the transmitted power by the reader device, G_{reader} is the gain of the reader antenna, G_{transp} is the gain of the transponder antenna, λ_{rf} is the electromagnetic wavelength, and r_{rf} is the distance between the reader and the transponder. The transponder modulates the received signal and scatters it back to the reader. The received power by the reader is

$$15 \quad P_{r,\text{reader}} = P_{t,\text{reader}} G_{\text{reader}}^2 G_{\text{transp}}^2 \left(\frac{\lambda_{rf}}{4\pi r_{rf}} \right)^4 E, \quad (3.11)$$

where E is the modulation or conversion efficiency of the transponder. Solving (3.11) for the detection distance gives

$$r_{rf} = \frac{\lambda_{rf}}{4\pi} \sqrt[4]{\frac{P_{t,\text{reader}} G_{\text{reader}}^2 G_{\text{transp}}^2 E}{P_{r,\text{reader}}}}. \quad (3.12)$$

Substituting (3.9) into (3.12) gives

$$r_{rf} = \frac{\lambda_{rf}}{4\pi} \sqrt[4]{\frac{2P_{t,reader} G_{reader}^2 G_{transp}^2 P_{ac} Z_{ac} Q_m^2}{\pi P_{r,reader} R_a^2 \omega_{rf}^2 \epsilon_0^2 \omega_{ac}^4 m^2 r_{ac}^2}}. \quad (3.13)$$

Tracking Resolution and Speed

The distance resolution of the tracking system is proportional to the physical length of the ultrasound pulse given as

$$5 \quad dl = v_a \tau, \quad (3.14)$$

where $v_a \approx 330$ m/s is the acoustic velocity in air and τ is the duration of the pulse. As a rule of thumb, the pulse duration is the inverse of the signal bandwidth B . Thus, the distance resolution can be given as

$$dl = \frac{v_a}{B} = \frac{v_a f_{ac}}{Q_m}. \quad (3.15)$$

10 For example, the distance resolution is approximately 3 cm with 10 kHz bandwidth. The distance measurement accuracy may be better than that depending on the signal-to-noise ratio.

The pulse repetition frequency is limited by the largest distance between a loudspeaker and the target L as

$$15 \quad f_r \leq \frac{v_a}{L}. \quad (3.16)$$

The tracking measurement frequency is further limited by the number of loudspeakers N and is given as

$$f_p = \frac{v_a}{NL}. \quad (3.17)$$

20 For example, the position refreshment rate is 1 Hz (one measurement/second) when the largest measurement distance is $L = 33$ m and the number of loudspeakers is $N = 10$.

Identification of Multiple Targets

Multiple targets can be identified using acoustical frequency division, electromagnetic frequency division or both. The electromagnetic frequency division is realized by using a narrowband matching between the antenna and the microphone element. The acoustic frequency division is realized by dimensioning the microphone elements such that each has different resonance frequency. Frequency division may require several reader systems and may thus be laborious to implement.

Assuming that there are three different electromagnetic frequency bands and three acoustical bands, it is possible to simultaneously track and identify 9 transponders.

Estimation of Realizable Performance

Let us estimate the realizable tracking range. Assume that the ultrasound frequency is 40 kHz and that the sound power of the ultrasound source is 1 mW. A device with similar performance can be found in [23]. The acoustic impedance of air is 410 Ns/m^2 .

The sound wavelength in air at 40 kHz is 8 mm. The membrane surface area of the microphone is 400 by 400 micrometers and the gap is $200 \mu\text{m}$. The membrane thickness is $1 \mu\text{m}$ and its effective mass is $0.3 \mu\text{g}$. The initial capacitance of the microphone element is $C_0 = \epsilon_0 A / g_0 = 14 \text{ fF}$. Let us further assume that the electrical quality factor of the microphone is 100 at 5 GHz resulting in a series resistance of 22Ω . The estimated parameters of the ultrasound tracking system are shown in *Table I*. The electrical modulation efficiency of the transponder as a function of r_{ac} is shown in Fig 5a. Fig 5b shows the microwave detection range of the transponder as a function of the ultrasound range. For example, if the acoustical distance is 6 m and the microwave frequency is 2 GHz, the transponder can be detected from 6 m distance.

Table I. Estimated parameters of the ultrasound tracking system.

Acoustic frequency	$f_{ac} = \omega_{ac} / (2\pi) = 40 \text{ kHz}$
Acoustic power	$P_{ac} = 1 \text{ mW}$
Transmitted RF-Power	$P_{t,reader} = 30 \text{ dBm}$

Acoustic impedance	$Z_{ac} = 410 \text{ Ns/m}^3$
Effective mass of the membrane	$m = 0.3 \mu\text{g}$
Reader antenna gain	$G_{reader} = 6 \text{ dBi}$
Transponder antenna gain	$G_{transp} = -10 \text{ dBi}$
Threshold level of the reader	$P_{r,reader} = -110 \text{ dBm}$
Antenna resistance	$R_a = 22 \Omega$
Electrical frequency	$f_{rf} = \omega_{rf} / (2\pi) = 1,2,3 \text{ GHz}$
Permittivity of vacuum	$\epsilon_0 = 8.854 \cdot 10^{-12} \text{ F/m}$
Mechanical quality factor	$Q_m = 20$

Tracking with Scanning Laser and Microwave Transponder

This Section considers a photo diode based transponder system for insect tracking. In accordance with figures 6a and 6b the insect 1 is equipped with a photo sensitive transponder 3 which is activated with scanning lasers 14, which illuminate the insect and the transponder 3. The laser signal is modulated and causes modulated backscatter at microwave frequencies when it illuminates the transponder 3.

The modulated laser signal can be either pulsed (Fig. 6b) or continuous (Fig. 6a). If a continuous signal is used, the target location is the intersection point of at least two laser beams at the moment the modulated microwave signal is detected. If a pulsed radar signal is used, the target distance can be solved from the time delay and a single laser beam is sufficient. Both continuous and pulsed radar tracking principles are shown in Fig. 6a (continuous) and Fig. 6b (pulsed).

Photovoltaic Response of the Transponder

The transponder consists of a photo diode that is matched to an antenna. A schematic layout of the transponder is shown in Fig. 7 top with its equivalent electrical circuit at the bottom of Fig. 7.

The absorbed photons in the photo diode create electron-hole-pairs in the diode. The procedure can be described with a current generator, whose current as a function of the absorbed light power P_L is given as

$$I_L = P_L R_\lambda, \quad (4.1)$$

where R_λ is the responsivity (typically ~ 0.5 A/W) of the diode. The diode current is given as

$$I_D = I_{sat} \left(e^{\frac{eV_D}{\eta kT}} - 1 \right), \quad (4.2)$$

where η is the ideality factor, $k = 1.38 \cdot 10^{-23}$ J/K is the Boltzmann's constant, T is the temperature, $e = 1.60 \cdot 10^{-19}$ C is the elementary charge, I_{sat} is the saturation current, and V_D is the voltage over the diode. Let us assume that the shunt and load resistances, R_{sh} and Z_L (in fig. 7) are very large. Then, the current through the diode equals the current produced by the absorbed light and the voltage across the diode can be written as

$$V_D = \frac{\eta kT}{e} \ln \left(\frac{P_L R_\lambda + I_{sat}}{I_{sat}} \right). \quad (4.3)$$

The voltage affects both the junction resistance and capacitance. The small-signal junction resistance of the diode is

$$r_j = \frac{1}{dV/dI} = \frac{\eta kT}{e I_{sat}} e^{-\frac{eV_D}{\eta kT}}. \quad (4.4)$$

The junction capacitance is given as

$$C_j = \frac{C_{j0}}{\left(1 - \frac{V_D}{\Phi_i}\right)^\gamma}, \quad (4.5)$$

where Φ_i is the junction potential and γ is the profile parameter for the depletion capacitance and is 0.5 for a uniformly doped junction.

Electromagnetic Detection Distance

5 The impedance of the diode (Fig. 7) seen from the load is

$$Z_D = R_s + \frac{r_j R_{sh}}{R_{sh} + r_j + j\omega r_j R_{sh} C_j}. \quad (4.6)$$

The junction resistance is very large at relatively low irradiance levels and can be assumed infinite. For example, the junction resistance of BPV10 photo diode chip (Vishay Semiconductors) is 25 M Ω in dark conditions and 5.8 k Ω with 1 mW/cm² irradiance. In addition, the shunt resistance is typically on the order of M Ω and can be neglected. Equation (4.6) becomes

$$Z_D \approx R_s + \frac{1}{j\omega C_j}. \quad (4.7)$$

The diode is illuminated with a modulated light source and its load impedance is infinite at DC. The modulated light changes the forward bias of the diode and modifies its junction capacitance. The alternating junction capacitance causes modulated backscatter. The conversion efficiency of the transponder is

$$E = |\Delta\rho|^2 = \left| \frac{\Delta C_j}{2\omega R_s C_{j0}^2} \right|^2, \quad (4.8)$$

where $\Delta C_j = C_{j,\max} - C_{j0}$. The microwave detection distance of the transponder is given by (3.12).

20 Tracking Resolution and Speed

The tracking resolution is limited by the beam width of the scanning laser. In practice the laser beam width can be millimeters.

The tracking speed depends on the resolution bandwidth of the receiver B_{res} which is limited by the modulation frequency of the laser f_m . Requiring that $B_{res} < f_m/10$, the measurement (refreshment) rate is $f_m/10$. For example, assuming that the tracking space is divided into 10 000 cells, and that two lasers, whose modulation frequency is 1 MHz, are used for tracking yields a refreshment rate of 5 Hz (insect position is updated 5 times/second).

Identification of Multiple Targets

Multiple target identification can be realized using optical wavelength division, electromagnetic frequency division, or both. Optical wavelength division is realized using photo diodes that are sensitive to different wavelengths. The optical wavelength division may require optical filters and could enable three different wavelength bands. The electromagnetic frequency division is realized using transponder antennas that are matched at different frequencies. Electromagnetic frequency division could also allow three different frequency bands such that the total number of identifiable transponders could be 9.

Estimation of Realizable Performance

Let us assume that the irradiance of the laser is 1 mW/cm². This irradiance level should be safe in normal use. The safety can be further increased by using 1400 nm wavelength that is safer for human eyes.

The transponder could be based on a BPV10 photo diode chip from Vishay Semiconductor whose parameters are shown in *Table II*.

Table II. Parameters of the BPV10 photo diode chip from Vishay Semiconductors.

Sensitivity	$R_\lambda = 0.55 \text{ A/W}$
Junction capacitance at zero bias	$C_{j0} = 11 \text{ pF}$
Series resistance	$R_s = 12 \text{ } \Omega$
Saturation current in dark	$I_{sat,d} = 1 \text{ nA}$

Saturation current in light (1 mW/cm ²)	$I_{sat,l} = 70 \mu\text{A}$
Junction potential	$\Phi_i = 1 \text{ V}$
Shunt resistance ¹	$R_{sh} = 1 \text{ G}\Omega$
Radiant sensitive area	$A = 0.78 \text{ mm}^2$
Size of the diode ¹	1 mm x 1 mm x 0.2 mm
Mass of the diode ¹	0.5 mg

¹ Estimated

The junction capacitance as a function of irradiance is shown in Fig. 8.

The modulation efficiency depends on the background irradiance level. The microwave detection range of the transponder at different background irradiance levels is shown in Fig. 9. The microwave link budget parameters equal those presented in *Table I*. For example, the transponder could be detected from a 10 m distance at 1 GHz with a 0.8 mW/cm² background irradiance level. A typical luminance level in office is 500 lx, which could correspond to approximately 0.1 mW/cm² irradiance depending on the used spectrum.

The measured real and imaginary parts of the diode impedance at different irradiance levels at 1.5 GHz are shown in Fig. 10 with the calculated curves. The diode ideality factor is assumed to be $\eta = 1$ and the junction profile parameter $\gamma = 0.5$ in the calculation.

The calculated and measured impedances agree well and show that the simple model of the photo diode in Fig. 7 can be used for designing a wireless photo detector. Fig. 10 also shows that very strong modulation is achieved at relatively low irradiance levels. Therefore, even a low power class I-laser scanner, whose laser power is limited to 1 mW, could be used for locating the target.

A photograph of the transponder is shown in Fig. 11. A packaged photo diode is used in this experiment due to poor availability of bare diode chips. A bare photo diode chip with an antenna optimized for low mass would enable a lightweight and small

transponder. For example, a 1 mm x 1mm x 0.2 mm size silicon diode chip weighs approximately 0.5 mg. Similarly, the loop antenna could be manufactured of 0.1 mm thick copper wire and matched directly to the diode without lumped elements. Such antenna with equal loop size to that used in the measurements would weigh 3 mg
5 providing a transponder weight comparable to that of typical harmonic radar transponders (3 mg) [11]. Further size and mass reductions of the transponder could be achieved by using higher microwave frequencies for interrogation. This, however, could necessitate a smaller effective photo diode area and thus stronger laser illumination.

Fig. 12 shows that sufficient modulation occurs at irradiance levels as low as 0.1
10 mW/cm². If using a bare diode chip instead of a packaged photo diode, the irradiance level should be 20 times higher and a class I-laser (1 mW power) could be used to produce spots up to 7 x 7 mm in size. Further, assuming that a laser scanner with a 1 kHz scanning rate (which is typical for commercially available scanners) was used with 7 x 7 mm spot, 0.5 m² area could be scanned in a second.

15 As a summary the invention relates to method and system for object localization. In the method an object 1, typically an insect is illuminated by at least one first type of signal, and response of the signal is detected, the object 1 equipped with a transponder 2, 3 backscattering the first type of signal, the transponder 2, 3 is illuminated also by a second type of signal affecting to the backscattering frequency of the transponder 2, 3,
20 and the backscattered signal from the transponder 2, 3 is detected in order to localize the object.

In an advantageous solution of the invention the transponder 2, 3 is illuminated by ultrasound or light as a second type of signal.

25 In another advantageous solution of the invention the first type of signal is microwave signal.

In another advantageous solution of the invention at least essentially continuous signal with multiple transmitters is used for second type of illumination.

In another advantageous solution of the invention a pulsed signal source 14' is used for second type of illumination.

In another advantageous solution of the invention the method is used for localization or tracking of insects.

In another advantageous solution of the invention the method is used for localization or tracking of humans.

5 In another advantageous solution of the invention the method is used for localization or tracking of vehicles.

References

- 10 [1] D. R. Reynolds and J. R. Riley, "Remote-sensing, telemetric and computer-based technologies for investigating insect movement: a survey of existing and potential techniques," *Computers and Electronics in Agriculture*, Vol. 35, pp. 271 – 307, 2002.
- [2] H. Staras and J. Shefer, Harmonic Radar Detecting and Ranging System for Automotive Vehicles, US Patent 3781879, 1972.
- 15 [3] E. A. Capaldi, A. D. Smith, J. L. Osborne, S. E. Fahrback, S. M. Farris, D. R. Reynolds, A. S. Edwards, A. Martin, G. E. Robinson, G. M. Poppy, and J. R. Riley, "Ontogeny of orientation flight in the honeybee revealed by harmonic radar," *Nature*, vol. 403, pp. 537–540, 2000.
- 20 [4] J. R. Riley, A. D. Smith, D. R. Reynolds, A. S. Edwards, J. L. Osborne, I. H. Williams, N. L. Carreck, and G. M. Poppy, "Tracking bees with harmonic radar," *Nature*, vol. 379, pp. 29–30, 1996.
- [5] J. L. Osborne, S. J. Clark, R. J. Morris, I. H. Williams, J. R. Riley, A. D. Smith, D. R. Reynolds, and A. S. Edwards, "A landscape-scale study of bumblebee foraging range and constancy, using harmonic radar," *Journal of Applied Ecology*, vol. 36, pp. 519–533, 1999.
- 25 [6] E. T. Cant, A. D. Smith, D. R. Reynolds and J. L. Osborne, "Tracking butterfly flight paths across the landscape with harmonic radar," *Proceedings of the Royal Society B: Biological Sciences*, vol. 272, no. 1565, pp. 785–790, Apr. 2005.
- 30 [7] O. Ovaskainen, A. D. Smith, J. L. Osborne, D. R. Reynolds, N. L. Carreck, A. P. Martin, K. Niitepold, and I. Hanski, "Tracking butterfly movements with harmonic radar reveals an effect of population age on movement distance," *Proceedings of the National Academy of Sciences*, vol. 105, no. 49, pp. 19090–19095, Dec. 2008.
- 35 [8] G. P. Svensson, P. G. Valeur, D. R. Reynolds, A. D. Smith, J. R. Riley, T. C. Baker, G. M. Poppy, and C. Löfstedt, "Mating disruption in *Agrotis segetum* monitored by harmonic radar," *Entomologia Experimentalis et Applicata*, vol. 101, pp. 111–121, 2001.
- 40 [9] G. L. Lövei, I. A. N. Stringer, C. D. Devine, and M. Cartellieri, "Harmonic radar – a method using inexpensive tags to study invertebrate movement on land," *New Zealand Journal of Ecology*, vol. 21, no. 2, pp. 187–193, 1997.

- [10] R. D. Brazee, E. S. Miller, M. E. Reding, M. G. Klein, B. Nudd, and H. Zhu, "A transponder for harmonic radar tracking of the black vine weevil in behavioral research," *Amer. Soc. Agricult. Eng. Trans.*, vol. 48, no. 2, pp. 831–838, 2005.
- 5 [11] J. R. Riley and A. D. Smith, "Design considerations for an harmonic radar to investigate the flight of insects at low altitude," *Computers and Electronics in Agriculture*. Amsterdam, The Netherlands: Elsevier, 2002, Vol. 35, pp. 151 – 169.
- 10 [12] E. T. Cant, A. D. Smith, D.R. Reynold and J. L. Osborne, "Tracing butterfly flight paths across the landscape with harmonic radar," *Proceedings of the Royal Society B: Biological Sciences*, Vol. 272, No. 1565, pp. 785 – 790, Apr. 2005.
- 15 [13] B. G. Colpitts and G. Boiteau, "Harmonic radar transceiver design: Miniature tags for insect tracking," *IEEE Transactions on Antennas and Propagation*, Vol. 52, No. 11, pp. 2825 – 2832, Nov. 2004.
- [14] D. E. N. Davies and R. J. Klensch, "Two-frequency secondary radar incorporating passive transponders," *IEE Electronics Letters*, Vol. 9, No. 25, pp. 592 – 593, Dec. 1973.
- 20 [15] H. Kwun, G. L. Burkhardt, J. L. Fisher, Detection of reinforcing steel corrosion in concrete structures using non-linear harmonic and intermodulation wave generation, US Patent 5180969, 1993.
- [16] V. Viikari, J. Saebboe, S. Cheng, M. Kantanen, M. Al-Nuaimi, T. Varpula, A. Lamminen, P. Hallbjörner, A. Alastalo, T. Mattila, H. Seppä, P. Pursula, and A. Rydberg, "Technical solutions for automotive intermodulation radar for detecting vulnerable road users," *Proceedings of the IEEE 69th Vehicular Technology Conference*, Barcelona, Spain, Apr. 26 – 29, 2009.
- 25 [17] V. Viikari, H. Seppä, T. Mattila, and A. Alastalo, "Wireless ferroelectric resonating sensor," submitted to *IEEE Transactions on Ultrasonics, Ferroelectrics and Frequency Control*, 2009.
- 30 [18] V. Viikari and H. Seppä, "Wireless MEMS Sensor Concept Based on Intermodulation Distortion," accepted with minor revision to *IEEE Sensors Journal*, 2009.
- [19] D. Psychoudakis, W. Moulder, C. Chi-Chih, Z. Heping, and J. L. Volakis, "A portable low-power harmonic radar system and conformal tag for insect tracking," *IEEE Antennas and Wireless Propagation Letters*, vol. 7, pp. 444 – 447, 2008.
- 35 [20] <http://www.recco.com/>
- [21] J. Roland, G. McKinnon, C. Backhouse, and P. D. Taylor, "Even smaller radar tags on insects," *Nature*, Vol. 381, p. 120, May 1996.
- 40 [22] D. Mascanzoni and H. Wallin, "The harmonic radar: a new method of tracing insects in the field," *Ecological Entomology*, Vol. 11, pp. 387 – 390, 1986.
- [23] <http://www.massa.com/datasheets/E-188-220%20Datasheet%20090427.pdf>
- 45

Claims:

1. A method for object localization, in which method,
 - an object (1) is illuminated by at least one first type of signal, and
 - response of the signal is detected,
- 5 **characterized** in that
 - the object (1) equipped with a transponder (2, 3) backscattering the first type of signal,
 - the transponder (2, 3) is illuminated also by a second type of signal affecting to the backscattering frequency of the transponder (2, 3), and
 - 10 • the backscattered signal from the transponder (2, 3) is detected in order to localize the object.
2. A method in accordance with claim 1, **characterized** in that the transponder (2, 3) is illuminated by ultrasound as a second type of signal.
3. A method in accordance with claim 1, **characterized** in that the transponder (2, 3) is
15 illuminated by light as a second type of signal.
4. A method in accordance with any previous claim, **characterized** in that the first type of signal is microwave signal.
5. A method in accordance with any previous claim, **characterized** in that at least essentially continuous signal with multiple transmitters is used for second type of
20 illumination.
6. A method in accordance with any claim 1-4, **characterized** in that pulsed signal source is used for second type of illumination.
7. A method in accordance with any previous claim, **characterized** in that it is used for localization or tracking of insects.
- 25 8. A method in accordance with any previous claim, **characterized** in that it is used for localization or tracking of humans.

9. A method in accordance with any previous claim, **characterized** in that it is used for localization or tracking of vehicles.
10. A system for object localization, which system comprises
- means (4, 14) for illuminating an object (1) by at least one type of signal, and
 - detection means (5, 15) for detecting a response of the first type of signal,
- 5 **characterized** in that the system further includes
- a transponder (2, 3) attached to the object (1), the transponder backscattering the first type of signal and being also sensitive to another type of signal such that it affects to the frequency backscattered from the transponder (2, 3),
 - 10 • second illuminating means (4, 14, 14') for illuminating the transponder (2, 3) also by a second type of signal affecting to the backscattering frequency of the transponder (2, 3), and
 - the backscattered signal from the transponder (2, 3) is detected in order to localize the object.
- 15 11. A system in accordance with claim 1, **characterized** in that the second illuminating means (4) are ultrasound transmitters (4).
12. A system in accordance with claim 1, **characterized** in that the detecting means are microwave receivers (5, 15).
13. A system in accordance with any previous claim, **characterized** in that the second
20 illuminating means (4, 14) are continuous transmitters (14).
14. A system in accordance with any claim 1-4, **characterized** in that the second illuminating means (4, 14) are pulsed transmitters (14').
15. A system in accordance with any previous claim, **characterized** in that the
25 transponder (2) is a capacitive ultrasound transponder equipped with antenna for microwave backscattering.

16. A system in accordance with any previous claim, **characterized** in that the transponder (3) is a photodiode equipped with antenna for microwave backscattering.

17. Use of a backscattering transmitter for insect detecting and tracking.

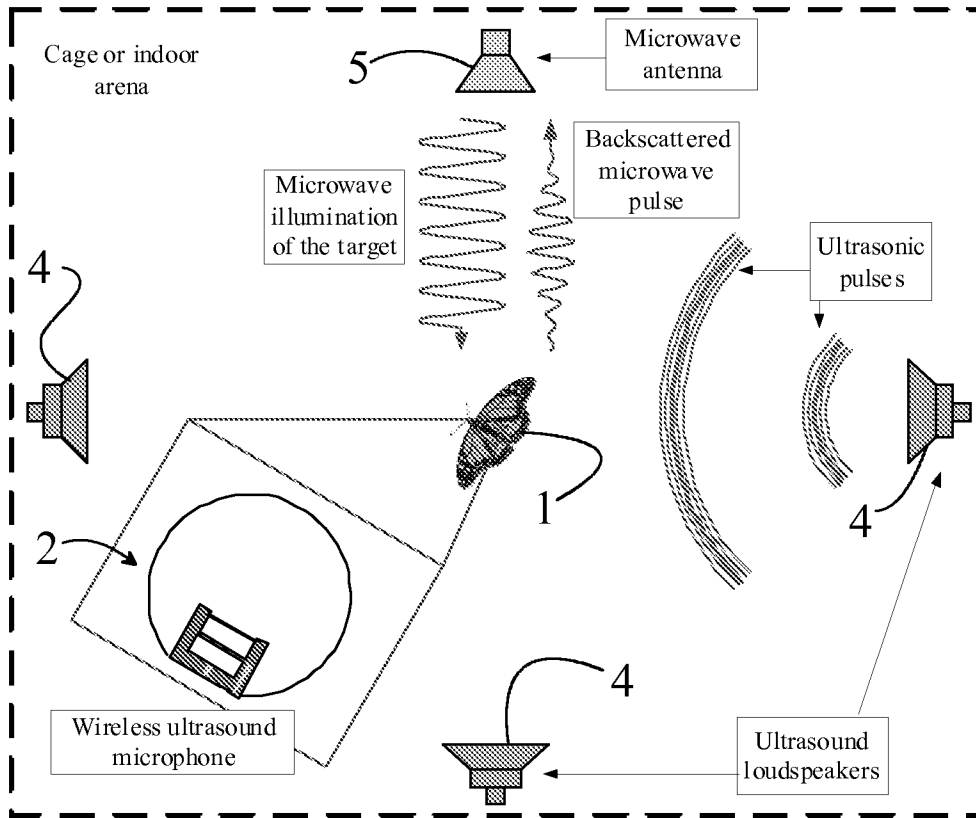

Fig. 1

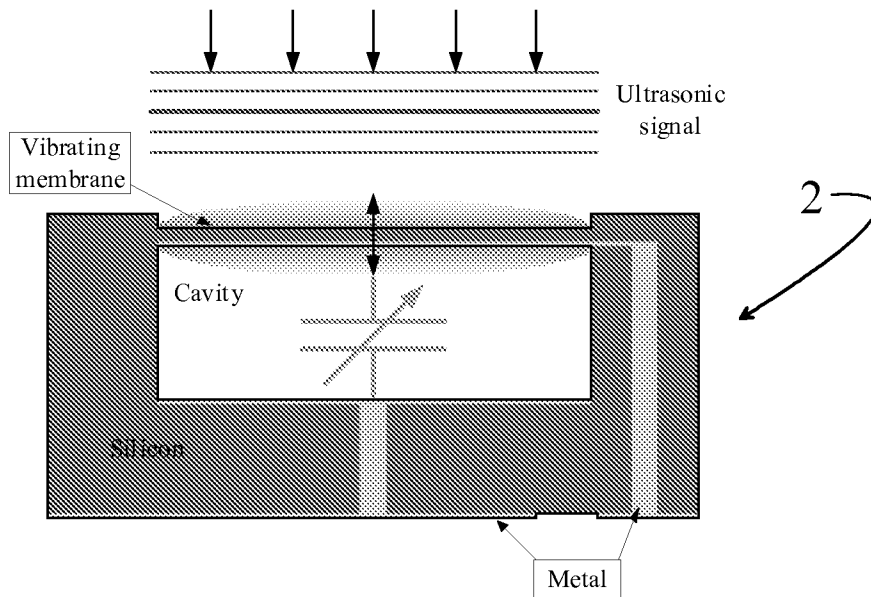

Fig. 2

2/6

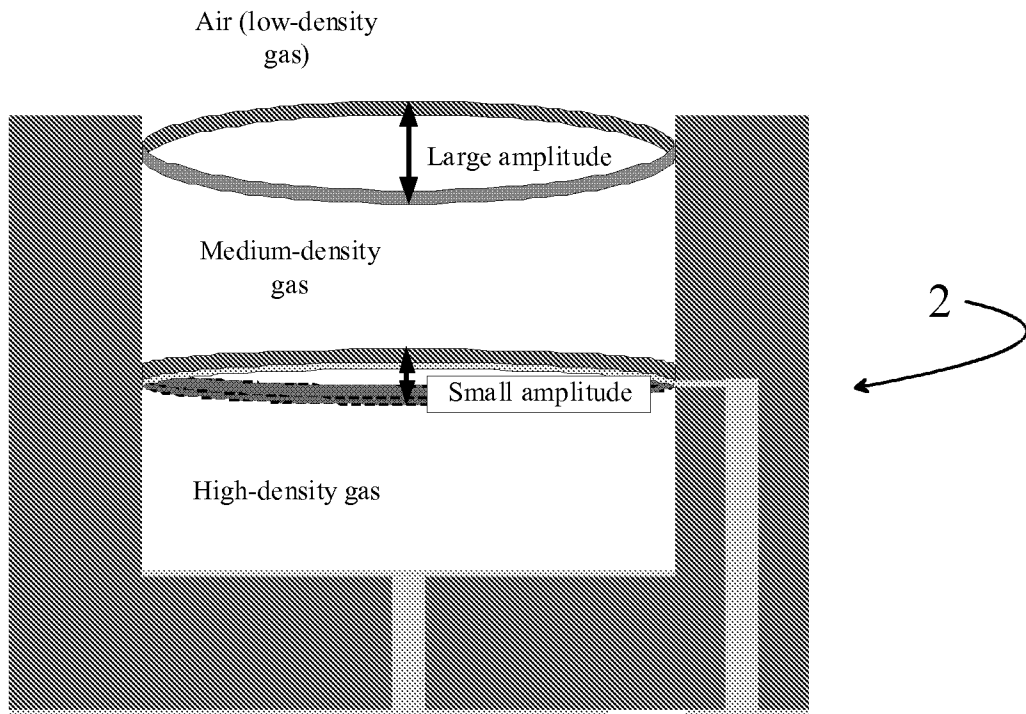

Fig. 3

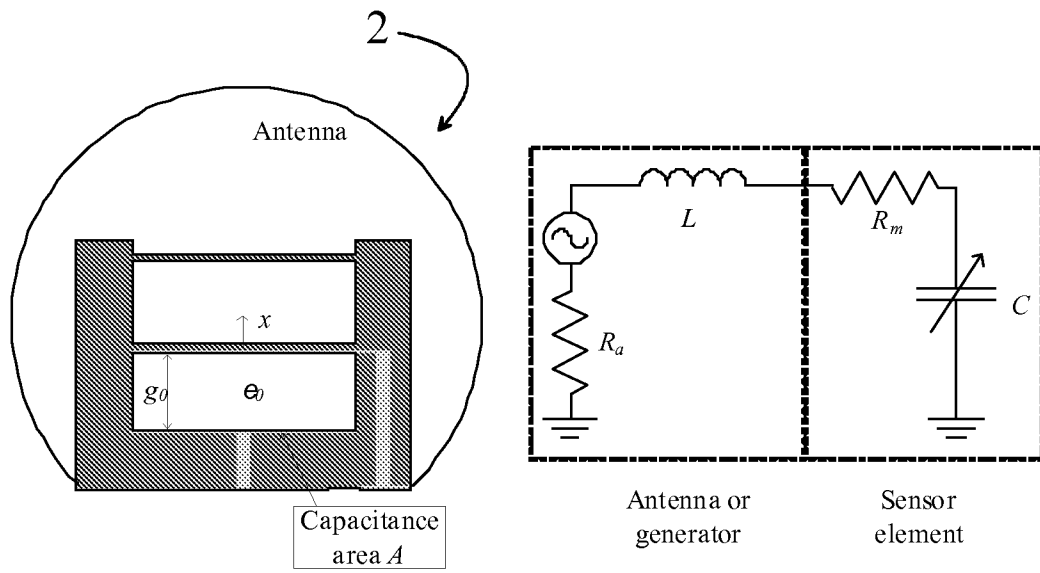

Fig. 4

3/6

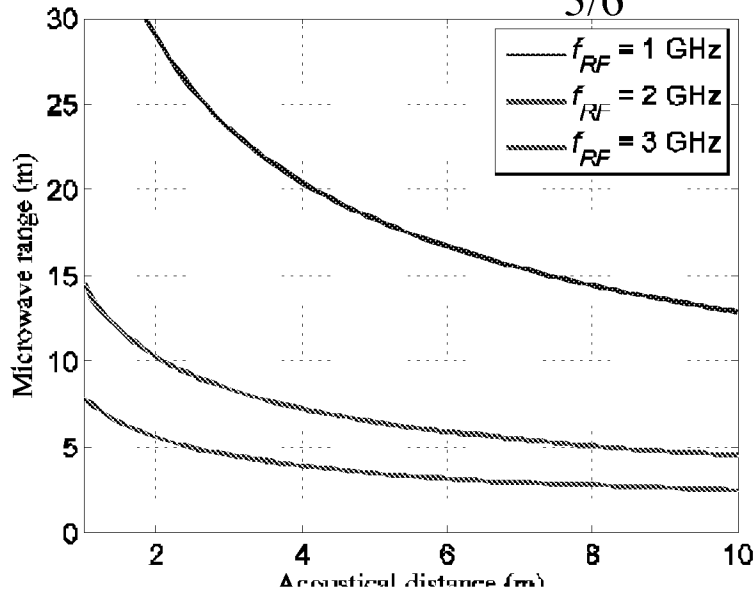

Fig. 5a

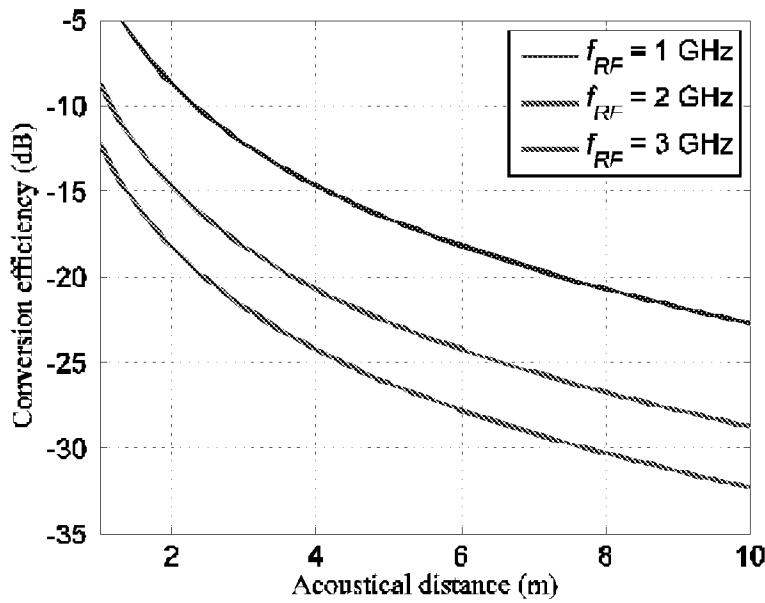

Fig. 5b

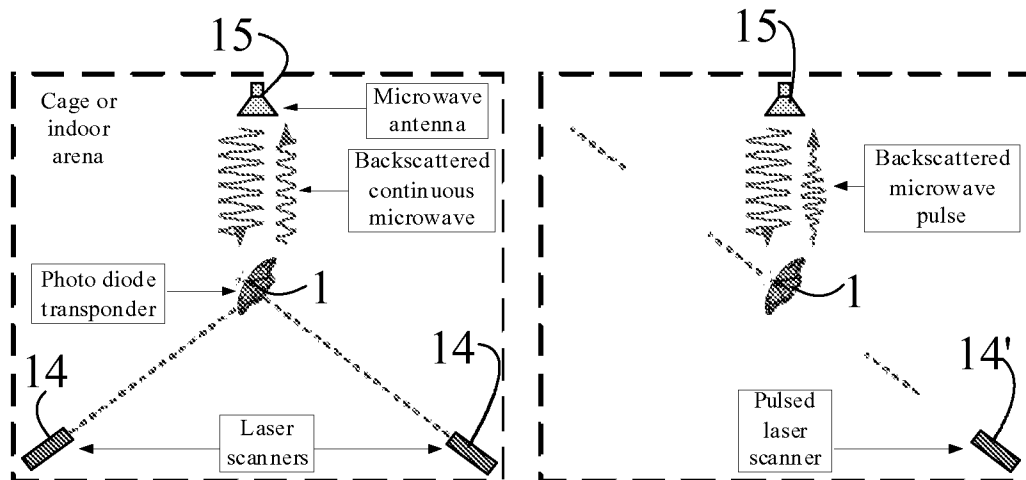

Fig. 6a

Fig 6b

4/6

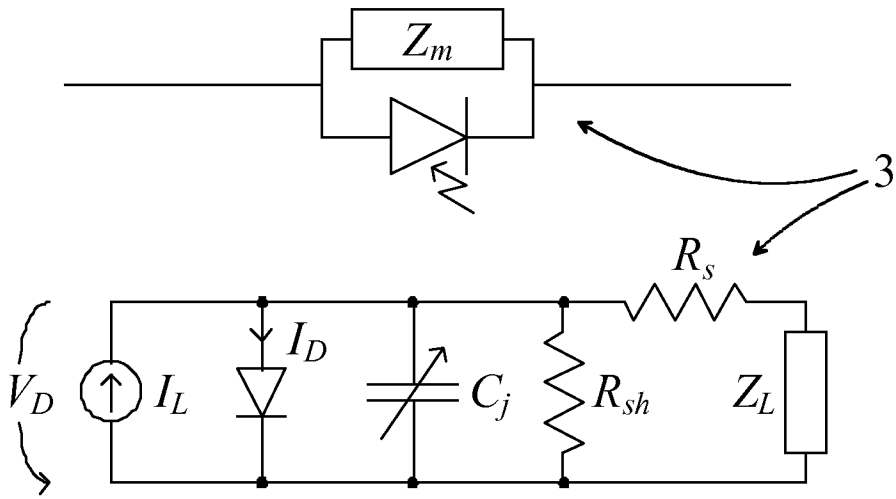

Fig. 7

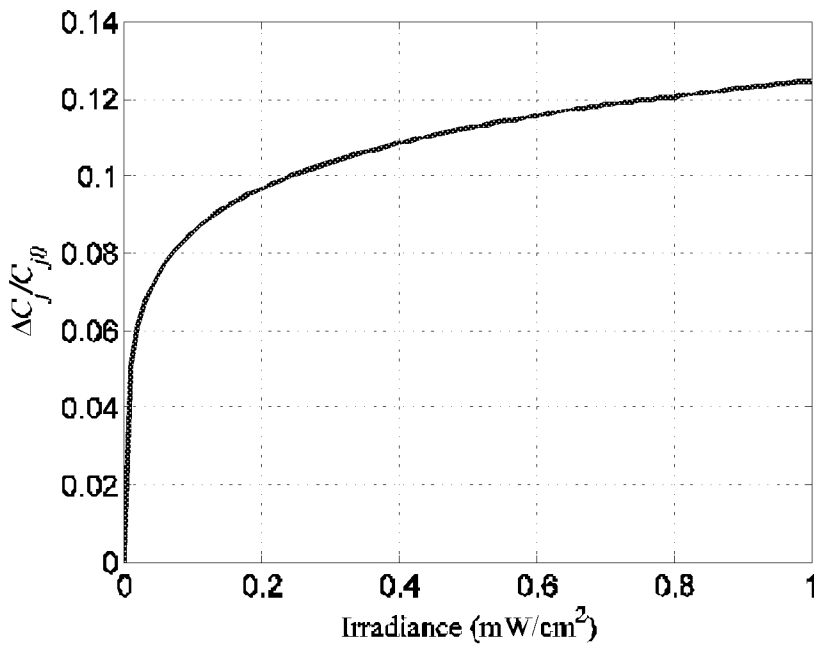

Fig. 8

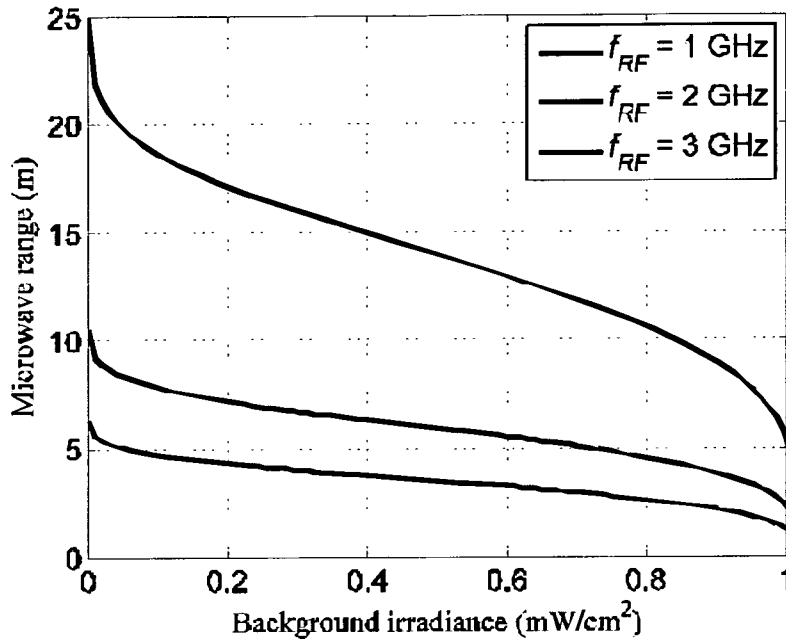

Fig. 9

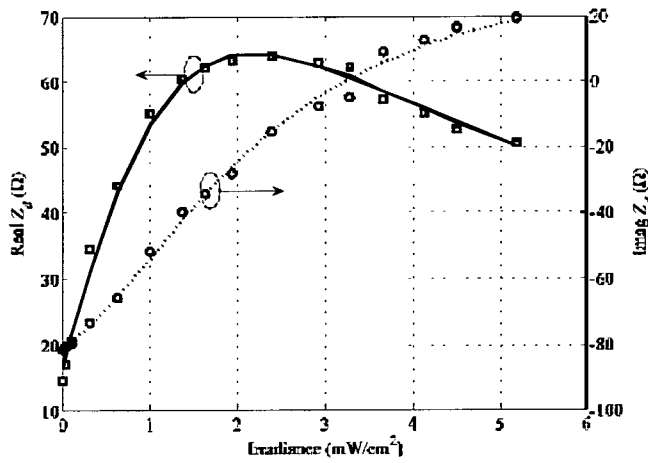

Fig. 10

3

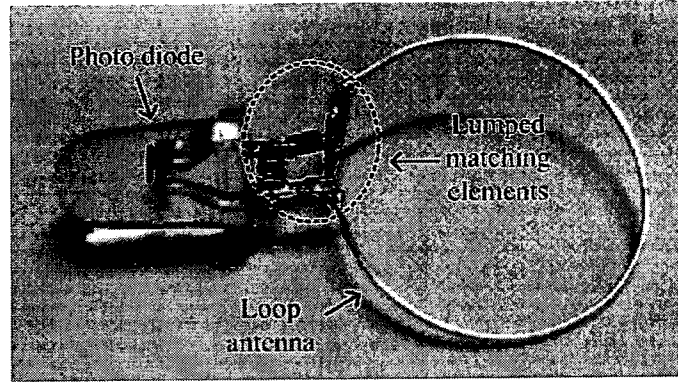

Fig. 11

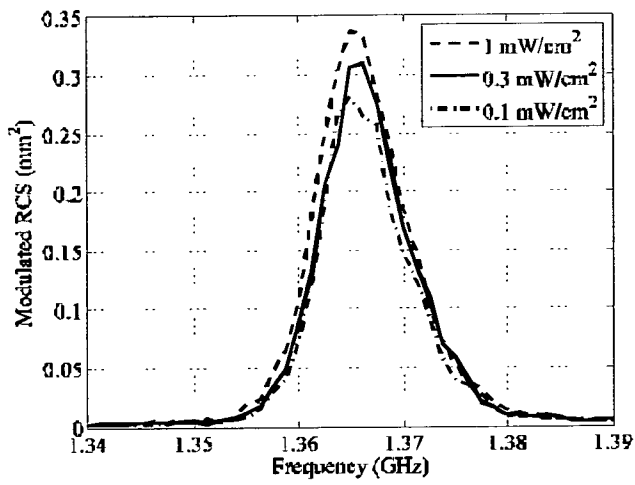

Fig. 12

INTERNATIONAL SEARCH REPORT

International application No.

PCT/FI2010/050814

A. CLASSIFICATION OF SUBJECT MATTER See extra sheet According to International Patent Classification (IPC) or to both national classification and IPC		
B. FIELDS SEARCHED Minimum documentation searched (classification system followed by classification symbols) IPC: G01S, A01K Documentation searched other than minimum documentation to the extent that such documents are included in the fields searched FI, SE, NO, DK Electronic data base consulted during the international search (name of data base and, where practicable, search terms used) EPO-Internal, WPI, XPI3E, XPIEE		
C. DOCUMENTS CONSIDERED TO BE RELEVANT		
Category*	Citation of document, with indication, where appropriate, of the relevant passages	Relevant to claim No.
X	COLPITTS, B. G. Harmonic Radar Tranceiver Design: Miniature Tags for Insect Tracking. IEEE Trans. Ant. and Prog. November 2004, Vol. 52, No. 11, s. 2825-2832. abstract; figure 2	17
X	US 6369710 B1 (POTICNY D. M. et al.) 09 April 2002 (09.04.2002) abstract; column 1, lines 35-42; column 2, line 43 – column 3, line 5; figure 1	17
A	VOSSIEK et al. Wireless Local Positioning. IEEE Microwave Magazine. December 2003, Vol. 4, Iss. 4, s. 77-86. whole document	1-17
A	VOSSIEK et al. 'An Ultrasonic Multielement Sensor System for Position Invariant Object Identification'. Julkaisussa IEEE 1994 Ultrasonics Symposium, 1-4 November, 1994, Vol. 2, s. 1293-1297. abstract	1-17
<input type="checkbox"/> Further documents are listed in the continuation of Box C. <input checked="" type="checkbox"/> See patent family annex.		
* Special categories of cited documents: "A" document defining the general state of the art which is not considered to be of particular relevance "E" earlier application or patent but published on or after the international filing date "L" document which may throw doubts on priority claim(s) or which is cited to establish the publication date of another citation or other special reason (as specified) "O" document referring to an oral disclosure, use, exhibition or other means "P" document published prior to the international filing date but later than the priority date claimed		"T" later document published after the international filing date or priority date and not in conflict with the application but cited to understand the principle or theory underlying the invention "X" document of particular relevance; the claimed invention cannot be considered novel or cannot be considered to involve an inventive step when the document is taken alone "Y" document of particular relevance; the claimed invention cannot be considered to involve an inventive step when the document is combined with one or more other such documents, such combination being obvious to a person skilled in the art "&" document member of the same patent family
Date of the actual completion of the international search 08 February 2011 (08.02.2011)		Date of mailing of the international search report 21 February 2011 (21.02.2011)
Name and mailing address of the ISA/FI National Board of Patents and Registration of Finland P.O. Box 1160, FI-00101 HELSINKI, Finland Facsimile No. +358 9 6939 5328		Authorized officer Pasi Suvikunnas Telephone No. +358 9 6939 500

INTERNATIONAL SEARCH REPORT
Information on patent family members

International application No.
PCT/FI2010/050814

Patent document cited in search report	Publication date	Patent family members(s)	Publication date
US 6369710 B1	09/04/2002	None	
.....			

INTERNATIONAL SEARCH REPORT

International application No.
PCT/FI2010/050814

CLASSIFICATION OF SUBJECT MATTER

Int.Cl.

G01S 13/75 (2006.01)

A01K 11/00 (2006.01)

G01S 5/02 (2010.01)