

A. E. HA FER.
SLEIGH BOB.

APPLICATION FILED MAY 16, 1911.

999,778.

Patented Aug. 8, 1911.

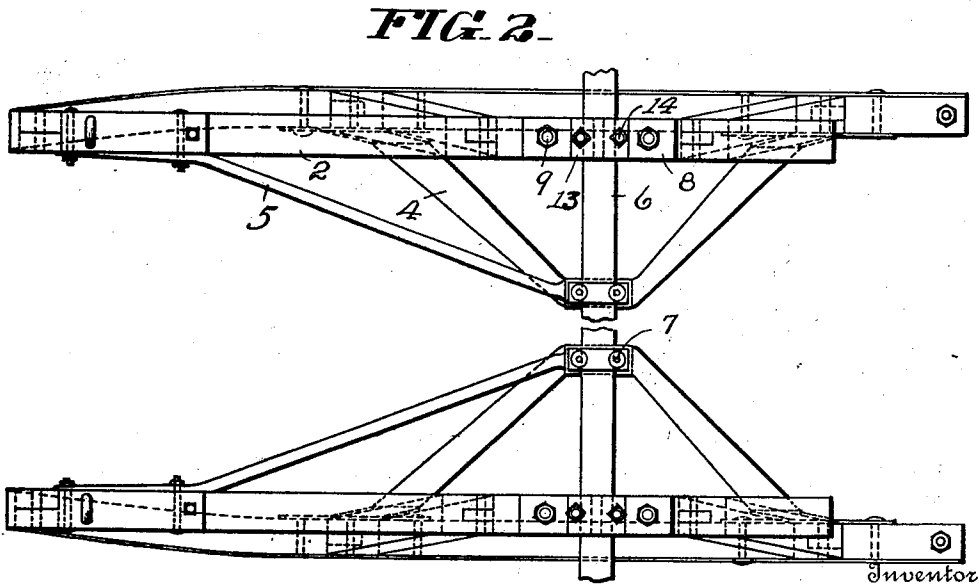
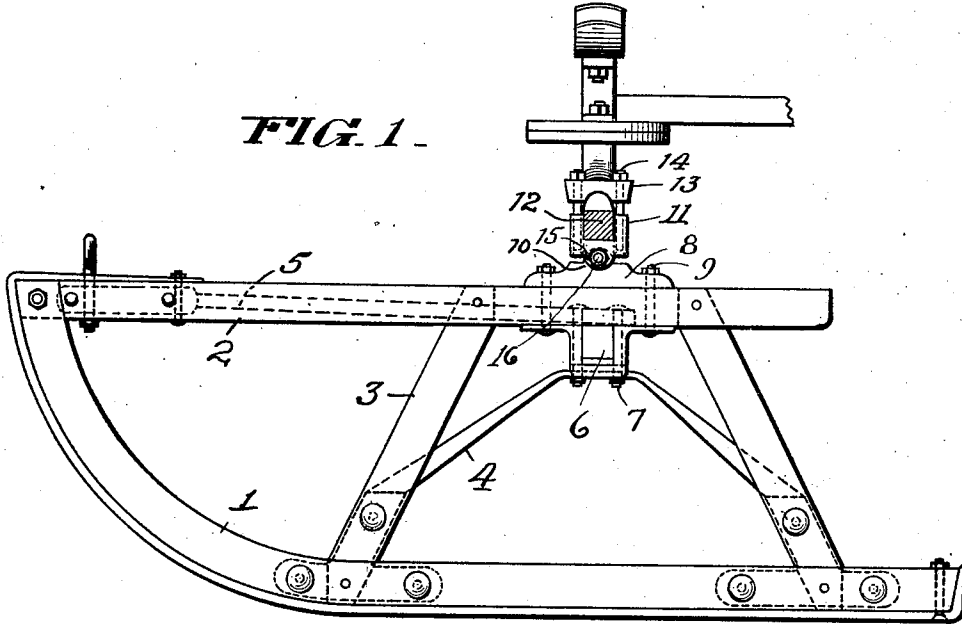

ADAM E. HA FER,
Inventor

Witnesses
Daniel Webster, Jr.
J. O. Kelly.

334

E. A. Kelly,
Attorney

UNITED STATES PATENT OFFICE.

ADAM E. HAFER, OF READING, PENNSYLVANIA.

SLEIGH-BOB.

999,778.

Specification of Letters Patent. Patented Aug. 8, 1911.

Application filed May 16, 1911. Serial No. 627,418.

To all whom it may concern:

Be it known that I, ADAM E. HAFER, citizen of the United States, residing at Reading, in the county of Berks and State of Pennsylvania, have invented certain new and useful Improvements in Sleigh-Bobs, of which the following is a specification.

This invention relates to improvements in sleigh bobs and the object is to provide a bob that can be conveniently and easily applied to the axles of a wagon, to convert it into a sleigh.

A further object is to provide means for adjusting the runners to different widths.

The invention consists of a pair of runners, adjustably secured to a cross bar, and carrying means whereby it may be easily applied to the axle of a wagon.

The invention is more fully described in the following specification and clearly illustrated in the accompanying drawing in which:—

Figure 1 is a side elevation of my bob, showing a portion of the vehicle to which it is attached. Fig. 2 is a plan view thereof.

The numeral 1 designates the runners; 2 the horizontal bars and 3 the supports between the horizontal bars and the runners, all of which form the usual bob.

The numeral 4 designates a pair of braces, the lower ends of which are secured to the runners, and which are adjustably secured at their middle portions to a cross-bar 6.

5 designates the top braces, the forward ends of which are secured to the horizontal bars at the forward end, and whose rear ends are secured to the upper side of the cross-bar 6. The braces 4 and 5 are both secured to the cross-bar 6 by the same bolts 7 which pass through the braces and are provided with nuts on the lower ends.

On the upper side of the horizontal bars 2, immediately over the cross-bar 6, I secure plates 8, held in position by means of bolts 9, and these plates are formed with jaw members 10 at the center, in which are secured rocking blocks 11. These blocks are formed with rectangular depressions for engaging the squared portion of a vehicle axle 12. These blocks are provided with cover plates 13 which engage the upper side of the axle, and bolts 14 pass through the

blocks and cover plates and lie along the vertical sides of the axle, while nuts are provided therefor on the upper side of the cover plates.

The rocking blocks are formed with jaw members 15 which register with the jaw members on the plates 8 and the jaw members are held together by bolts 16, which securely hold the parts together.

When it is desired to remove the bobs, and to convert the sleigh into a wagon, these bolts 16 are removed and the bobs may be taken from the axle and the wheels placed thereon. The rocking block is carried by the axle even when used as a wagon and to convert it into a sleigh, it will be only necessary to remove the wheels, and place the jaw members of the rocking blocks and the plates 8 together, place the bolts 16 in position therein, and the transformation is complete.

To secure adjustment of the runners, that is, when it is desired to increase or decrease the distance between the runners, the nuts on the bolts 7 are loosened, and the runners moved along the cross-bar 6 to the desired position, when they are secured by tightening the nuts.

It will be seen that my bob may be easily and rapidly secured to a wagon, thus converting it into a sleigh, and that it is applicable to wagons of different widths. The rocking block may be carried by the wagon without any inconvenience, as it may be secured to the axle at any point inside the hub bearing point.

Having thus fully described my invention, what I claim and desire to secure by Letters Patent is:—

In a sleigh attachment for vehicles, a pair of runners having horizontal bars and supporting braces; horizontal braces secured to the horizontal bars; lower braces secured to the runners; a cross-bar to which both sets of braces are secured adjustably by a single set of bolts, and securing plates on the upper edges of the horizontal bars, said plates having jaw members formed on their upper sides, in combination with a vehicle axle; a pair of rocking blocks formed with rectangular cavities in which the axle rests; cover plates for the rocking blocks, engaging the upper side of the axle; bolts passing through

the rocking blocks and cover plates to secure them to the axle; jaw members formed on the rocking blocks adapted to register with the jaw members on the securing plates and
5 bolts for removably securing the rocking block jaw members to the securing plate jaw members.

In testimony whereof I affix my signature in presence of two witnesses.

ADAM E. HAFFER.

Witnesses:

ED. A. KELLY,
J. O. R. KELLY.

Copies of this patent may be obtained for five cents each, by addressing the "Commissioner of Patents, Washington, D. C."
