

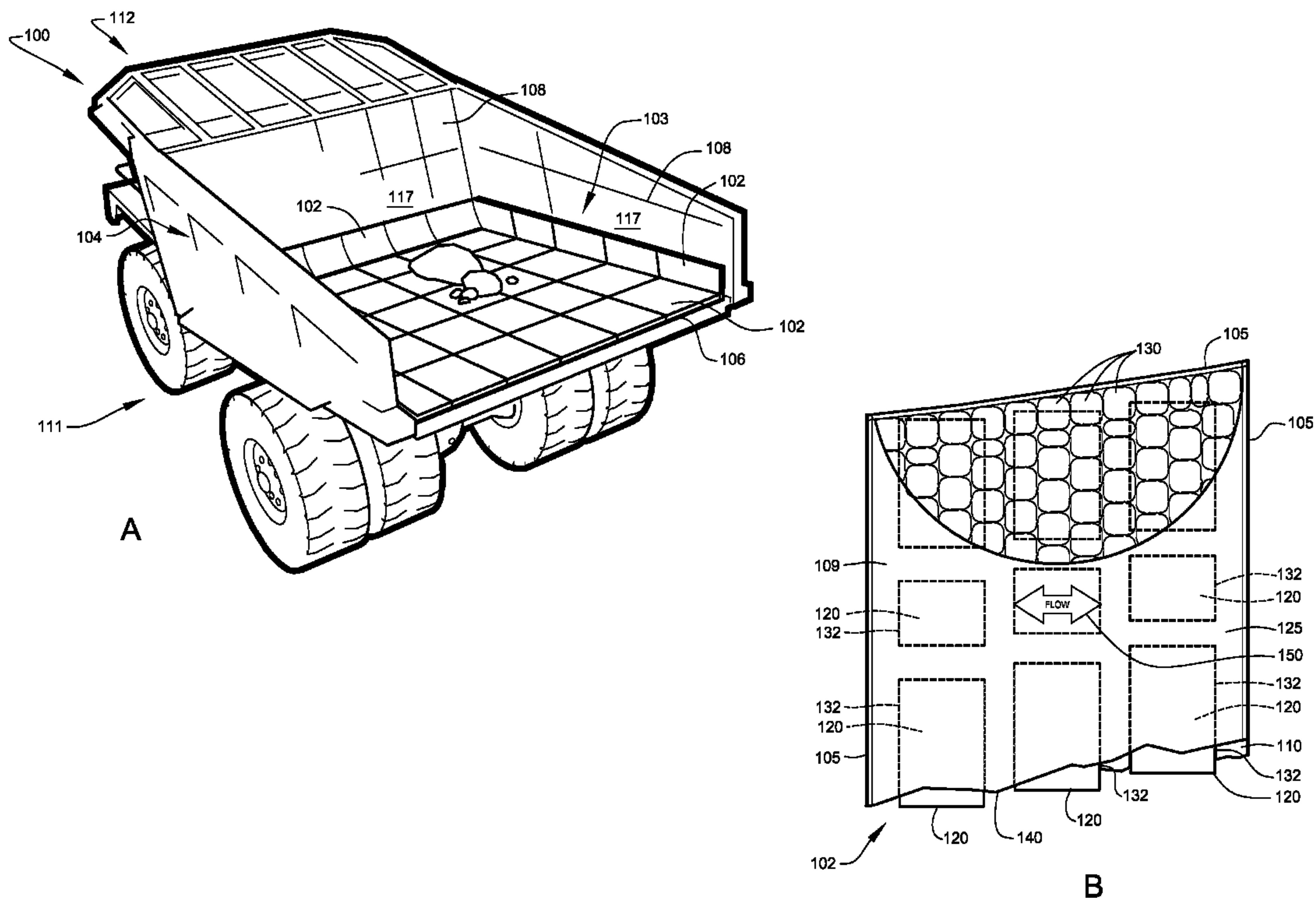

(86) Date de dépôt PCT/PCT Filing Date: 2011/01/21
 (87) Date publication PCT/PCT Publication Date: 2011/07/28
 (45) Date de délivrance/Issue Date: 2018/05/29
 (85) Entrée phase nationale/National Entry: 2013/07/16
 (86) N° demande PCT/PCT Application No.: US 2011/022134
 (87) N° publication PCT/PCT Publication No.: 2011/091310
 (30) Priorités/Priorities: 2010/01/25 (US61/298,116);
 2010/04/10 (US61/322,822); 2011/01/20 (US13/010,492)

(51) Cl.Int./Int.Cl. *B60R 13/01* (2006.01),
B60P 3/00 (2006.01), *B60P 7/00* (2006.01)
 (72) Inventeurs/Inventors:
 DUNN, DONALD C., US;
 HOFBERGER, JERRY F., US
 (73) Propriétaire/Owner:
 CORROSION ENGINEERING, INC., US
 (74) Agent: BORDEN LADNER GERVAIS LLP

(54) Titre : SYSTEMES DE CHEMISAGE
 (54) Title: LINER SYSTEMS



(57) **Abrégé/Abstract:**

A system relating to lining heavy-material hauling and processing equipment comprising a plurality of magnetically attached liner panels installed without the need to drill or otherwise alter the truck bed or device being lined.

(12) INTERNATIONAL APPLICATION PUBLISHED UNDER THE PATENT COOPERATION TREATY (PCT)

(19) World Intellectual Property Organization
International Bureau(43) International Publication Date
28 July 2011 (28.07.2011)(10) International Publication Number
WO 2011/091310 A4

(51) International Patent Classification:

B60P 3/00 (2006.01) *B60P 7/00* (2006.01)
B62D 29/00 (2006.01)

(21) International Application Number:

PCT/US2011/022134

(22) International Filing Date:

21 January 2011 (21.01.2011)

(25) Filing Language:

English

(26) Publication Language:

English

(30) Priority Data:

61/298,116 25 January 2010 (25.01.2010) US
61/322,822 10 April 2010 (10.04.2010) US
13/010,492 20 January 2011 (20.01.2011) US(71) Applicant (for all designated States except US): **CORROSION ENGINEERING, INC.** [US/US]; P.O. Box 5670, Mesa, AZ 85211 (US).

(72) Inventors; and

(75) Inventors/Applicants (for US only): **DUNN, Donald, C.** [US/US]; P.O. Box 5670, Mesa, AZ 85211 (US). **HOFBERGER, Jerry, F.** [US/US]; 148 S. Nina Circle, Mesa, AZ 85211 (US).(74) Agent: **STONEMAN, Martin, L.**; Stoneman Law Patent Group, P.O. Box 40070, Phoenix, AZ 85067 (US).

(81) Designated States (unless otherwise indicated, for every kind of national protection available): AE, AG, AL, AM, AO, AT, AU, AZ, BA, BB, BG, BH, BR, BW, BY, BZ,

CA, CH, CL, CN, CO, CR, CU, CZ, DE, DK, DM, DO, DZ, EC, EE, EG, ES, FI, GB, GD, GE, GH, GM, GT, HN, HR, HU, ID, IL, IN, IS, JP, KE, KG, KM, KN, KP, KR, KZ, LA, LC, LK, LR, LS, LT, LU, LY, MA, MD, ME, MG, MK, MN, MW, MX, MY, MZ, NA, NG, NI, NO, NZ, OM, PE, PG, PH, PL, PT, RO, RS, RU, SC, SD, SE, SG, SK, SL, SM, ST, SV, SY, TH, TJ, TM, TN, TR, TT, TZ, UA, UG, US, UZ, VC, VN, ZA, ZM, ZW.

(84) Designated States (unless otherwise indicated, for every kind of regional protection available): ARIPO (BW, GH, GM, KE, LR, LS, MW, MZ, NA, SD, SL, SZ, TZ, UG, ZM, ZW), Eurasian (AM, AZ, BY, KG, KZ, MD, RU, TJ, TM), European (AL, AT, BE, BG, CH, CY, CZ, DE, DK, EE, ES, FI, FR, GB, GR, HR, HU, IE, IS, IT, LT, LU, LV, MC, MK, MT, NL, NO, PL, PT, RO, RS, SE, SI, SK, SM, TR), OAPI (BF, BJ, CF, CG, CI, CM, GA, GN, GQ, GW, ML, MR, NE, SN, TD, TG).

Declarations under Rule 4.17:

— of inventorship (Rule 4.17(iv))

Published:

— with international search report (Art. 21(3))
— with amended claims (Art. 19(1))

(88) Date of publication of the international search report:

29 December 2011

Date of publication of the amended claims: 16 February 2012

(54) Title: LINER SYSTEMS

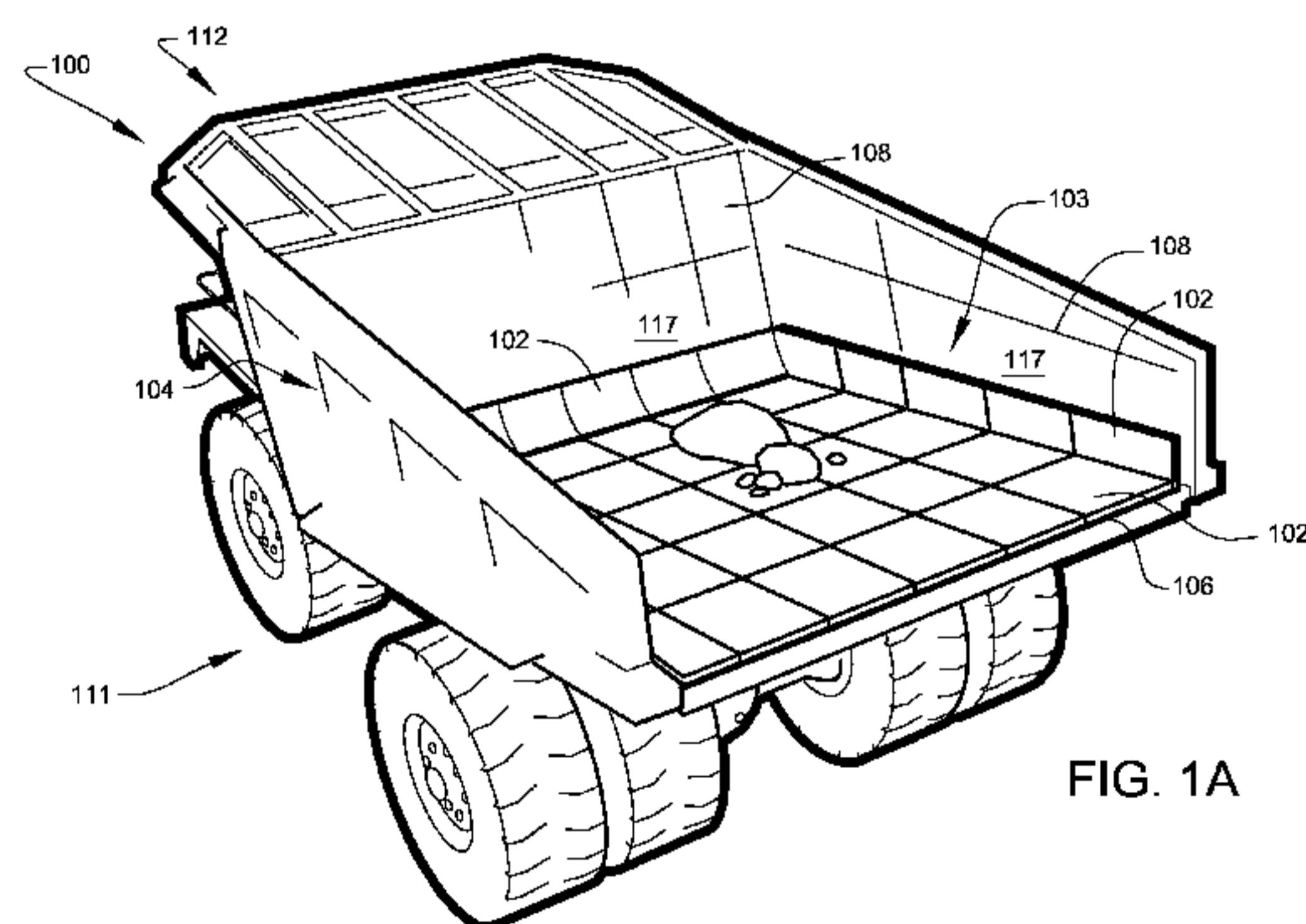

FIG. 1A

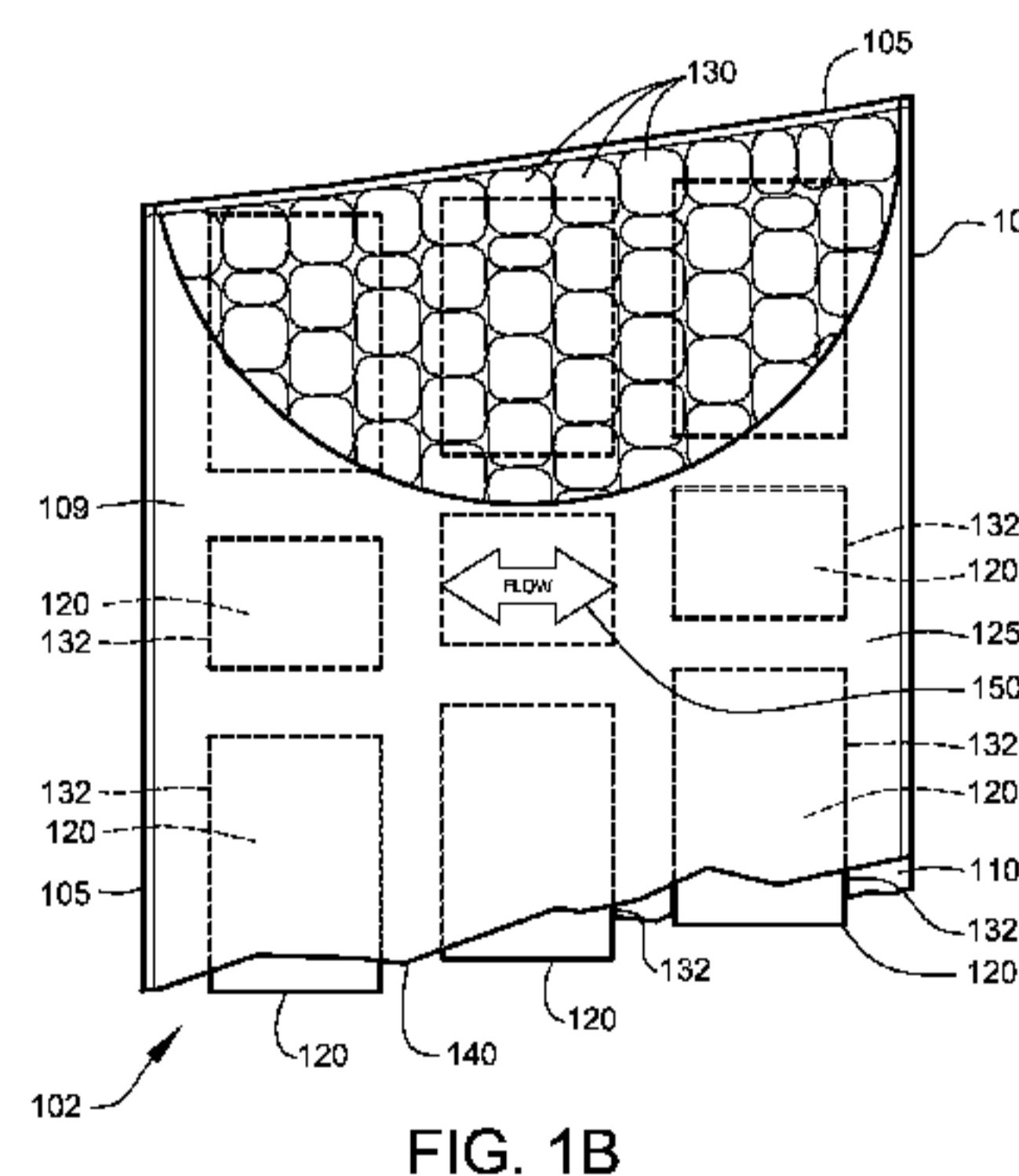

FIG. 1B

(57) Abstract: A system relating to lining heavy-material hauling and processing equipment comprising a plurality of magnetically attached liner panels installed without the need to drill or otherwise alter the truck bed or device being lined.

LINER SYSTEMS

BACKGROUND

This invention relates to providing a system for improved liners used on heavy machinery such as, for example, heavy material hauling portions of vehicles and machines used in mining operations. More particularly, this invention relates to providing a system for improving the installation of heavy-material hauling vehicle liners and processing equipment liners so as to avoid having to permanently alter or damage the heavy-material hauling vehicle or processing equipment. One of the problems with prior art liner panels is they are installed with bolts that require drilling of the equipment liner bed and, therefore, cause at least some damage to the bed to install a liner panel. Furthermore, replacement of a bolted-in liner panels requires a maintenance period when the vehicle cannot be used as well as alignment of bolt patterns used in the initial installation.

OBJECTS AND FEATURES OF THE INVENTION

A primary object and feature of the present invention is to provide a system overcoming the above-mentioned problem(s).

It is a further object and feature of the present invention is to provide such a system that improves the wear, durability and performance of bed liners for heavy material haulers.

It is a further object and feature of the present invention to provide such system that improves the wear, durability and performance of liners for heavy-material processing equipment, particularly used in the mining industry.

It is a further object and feature of the present invention to provide such a system that installs without the need to alter, drill, or damage the vehicle or equipment.

It is a further object and feature of the present invention to provide such a system that installs without the need to alter, drill or damage a vehicle heavy-material hauling bed.

WO 2011/091310

PCT/US2011/022134

It is a further object and feature of the present invention to provide such a system that installs magnetically without breaking free during normal use of the liner.

It is a further object and feature of the present invention to provide such a system that assists replacing liners with minimal equipment "down-time" and reduced labor costs associated with such maintenance.

A further primary object and feature of the present invention is to provide such a system that is efficient, inexpensive, and handy. Other objects and features of this invention will become apparent with reference to the following descriptions.

SUMMARY OF THE INVENTION

In accordance with a preferred embodiment hereof, this invention provides a system, relating to providing replaceable wear surfaces on abrasive-material handling-equipment, comprising: at least one replaceable surface structured and arranged to provide at least one replaceable surface onto the abrasive-material handling-equipment; wherein such at least one replaceable surface comprises at least one wear-resister element structured and arranged to resist wear of such at least one replaceable surface; wherein such at least one replaceable surface comprises at least one magnet structured and arranged to magnetically attach such at least one replaceable surface to the abrasive-material handling-equipment; and wherein such at least one magnet comprises at least one permanent attacher structured and arranged to permanently attach with such at least one replaceable surface. Moreover, it provides such a system wherein such at least one permanent attacher comprises a single integral-matrix bond structured and arranged to integrally-matrix bond such at least one magnet with such at least one replaceable surface. Additionally, it provides such a system wherein such at least one wear-resister element comprises at least one ceramic element structured and arranged to increase wearability of such at least one replaceable surface. Also, it

WO 2011/091310

PCT/US2011/022134

provides such a system further comprising: at least one vehicle, having at least one ferromagnetic surface, structured and arranged to handle abrasive material; wherein such at least one vehicle comprises at least one container portion structured and arranged to contain the abrasive material; wherein such at least one container portion comprises such at least one ferromagnetic surface; and wherein such at least one container portion comprises at least one of such replaceable wear surface magnetically attached to such at least one ferromagnetic surface. In addition, it provides such a system wherein such integral-matrix bond comprises at least one elastomeric material.

And, it provides such a system wherein such integral-matrix bond comprises rubber. Further, it provides such a system wherein such at least one elastomeric material comprises rubber. Even further, it provides such a system wherein such at least one magnet comprises a plurality of magnets. Moreover, it provides such a system wherein such plurality of magnets comprises a plurality of ceramic magnets. Additionally, it provides such a system wherein such plurality of magnets comprises at least six ceramic magnets structured and arranged in at least one aligned polarity so as to increase the magnetic attaching of such at least one replaceable surface to the abrasive-material handling-equipment. Also, it provides such a system wherein such wear-resistant element comprises a rubber thickness of between about one inch and about twelve inches.

In addition, it provides such a system wherein: such plurality of magnets is situate opposite such at least one ceramic element. And, it provides such a system further comprising: at least one vehicle, having at least one ferromagnetic surface, structured and arranged to handle abrasive material; wherein such at least one vehicle comprises at least one container portion structured and arranged to contain the abrasive material; wherein such at least one container portion comprises such at least one ferromagnetic

surface; and wherein such at least one container portion comprises at least one of such replaceable wear surface magnetically attached to such at least one ferromagnetic surface.

5 In accordance with another preferred embodiment hereof, this invention provides a system, relating to providing replaceable wear surfaces on abrasive-material handling-equipment, comprising: replaceable surface means for providing at least one replaceable surface; wherein such replaceable
10 surface means comprises wear-resister element means for resisting wear of such replaceable surface means when handling the abrasive material; wherein such replaceable surface means comprises magnet means for magnetically attaching such replaceable surface means to the equipment handling abrasive
15 material; and wherein such magnet means comprises permanent attacher means for permanently attaching with such replaceable surface means. Further, it provides such a system wherein such permanent attacher means comprises integral-matrix bond means for integral-matrix bonding of such magnet means with such
20 replaceable surface means. Even further, it provides such a system wherein such wear-resister element means comprises ceramic element means for increasing wearability of such replaceable surface means.

In accordance with another preferred embodiment hereof,
25 this invention provides a system, relating to providing replaceable wear surfaces on abrasive-material handling-equipment, comprising: at least one replaceable surface structured and arranged to provide at least one replaceable surface onto the abrasive-material handling-equipment; wherein
30 such at least one replaceable surface comprises at least one wear-resister element structured and arranged to resist wear of such at least one replaceable surface; wherein such at least one replaceable surface comprises at least one magnet structured and arranged to magnetically attach such at least one replaceable
35 surface to the abrasive-material handling-equipment; and wherein

such at least one magnet comprises at least one permanent
attacher structured and arranged to permanently attach with such
at least one replaceable surface. Even further, it provides
such a system wherein such at least one permanent attacher
5 comprises a single integral-matrix bond structured and arranged
to integrally-matrix bond such at least one magnet with such at
least one replaceable surface.

Even further, it provides such a system wherein such at
least one wear-resister element comprises at least one ceramic
10 element structured and arranged to increase wearability of such
at least one replaceable surface. Even further, it provides
such a system wherein: such integral-matrix bond comprises
rubber; and such at least one magnet comprises a plurality of
ceramic magnets.

15 In accordance with another preferred embodiment hereof,
this invention provides each and every novel feature, element,
combination, step and/or method disclosed or suggested by this
patent application.

BRIEF DESCRIPTION OF THE DRAWINGS

20 FIG. 1A shows a perspective view, illustrating a truck bed
equipped with liner panels of the liner systems, according to a
preferred embodiment of the present invention.

FIG. 1B shows a top view, partially in section,
illustrating a liner panel of the liner systems, according to
25 the preferred embodiment of FIG. 1.

FIG. 2 shows an end section view, of a radius-liner panel
according to the preferred embodiment of FIG. 1.

FIG. 3 shows a side section view, of a squared-edge liner
panel, according to the preferred embodiment of FIG. 1.

30 FIG. 4 shows a top view, partially in section, illustrating
another liner panel of the liner systems, according to another
preferred embodiment of the present invention.

FIG. 5 shows an end section view, of the liner panel
according to the preferred embodiment of FIG. 4.

35 DETAILED DESCRIPTION OF THE BEST MODES

AND PREFERRED EMBODIMENTS OF THE INVENTION

FIG. 1A shows a perspective view, illustrating a truck bed **104** equipped with liner panels **102** of the liner systems **100**, according to a preferred embodiment of the present invention.

5 FIG. 1B shows a top view, partially in section, illustrating a liner panel **102** of the liner systems **100**, according to a preferred embodiment of the present invention. FIG. 2 shows an end section view, of radius-liner panel **118**, according to the preferred embodiment of FIG. 1. FIG. 3 shows a
10 side section view of the liner panel **102** according to another preferred embodiment of FIG. 1.

Liner panels **102** are preferably used along the surfaces of the bed bottom **106** and bed sides **108** of heavy-material hauling and processing equipment **112**, preferably to provide a
15 replaceable wear layer on such surfaces, being particularly useful for trucks and other large-bed vehicle equipment **111** used to haul heavy materials, particularly those in the mining industry. One of the problems with prior art liner panels is they are installed with bolts that require drilling of the truck
20 bed **104** (equipment surface) and, therefore, cause at least some damage to such truck bed **104** to install a liner panel **102**. Furthermore, replacement of a bolted-in liner panel requires a maintenance period when the vehicle cannot be used as well as alignment of bolt patterns used in the initial installation.
25 The present invention provides a magnetically-attached liner panel **102** preferably installed without the need to drill or otherwise alter the truck bed **104** being lined or be concerned with bolt-hole patterns. Furthermore, the present invention provides a ceramic reinforced rubber wear layer **125** to improve
30 the wearability and longevity-of-use of the magnetically-attached liner panel **102**.

Liner panels **102** (at least embodying herein at least one replaceable surface structured and arranged to provide at least one replaceable surface onto the abrasive-material handling-
35 equipment; and, at least embodying herein replaceable surface

means for providing at least one replaceable surface) of the system are preferably configured to conform to the geometry of the surfaces to which they are applied, and therefore preferably comprise a range of sizes and shapes. In one preferred
5 embodiment of the system, liner panel **102** preferably comprises a radius-liner panel **118** for lining a non-linear, preferably arced surface, as shown, or, alternately preferably, comprises a squared-edge liner panel **122** for lining a linear surface, as shown. Whether radius (curved) or linear (flat), liner panel
10 **102** preferably comprises at least one frame portion **105**, preferably comprising a bottom portion **110**, side portions **115** and a top portion **109**. Bottom portion **110** (the side that couples to the vehicle/device) preferably comprises a steel plate, preferably comprising at least one, and preferably
15 multiple, "punch-out" aperture portions **132** within which peripheries magnetic coupling element(s) **120** is/are placed, as shown. Bottom portion **110** containing magnetic coupling element(s) **120**,

Liner panel **102** preferably comprises at least one wear
20 layer **125**, preferably a ceramic-rubber wear layer **125**, preferably placed about parallel to the bottom portion **110**. Upon reading this specification, those with ordinary skill in the art will now appreciate that, under appropriate circumstances, considering such issues as design preference,
25 user preferences, marketing preferences, cost, structural requirements, available materials, technological advances, etc., other ceramic wear-layer placement arrangements such as, for example, multiple levels, non-parallel, serpentine, etc., may suffice.

30 Preferably, wear layer **125** comprises a layer of ceramic, preferably a plurality of ceramic cubes **130** (at least embodying herein wherein such wear-resister element means comprises ceramic element means for increasing wearability of such replaceable surface means; and, at least embodying herein
35 wherein such at least one wear-resister element comprises at

WO 2011/091310

PCT/US2011/022134

least one ceramic element structured and arranged to increase wearability of such at least one replaceable surface), as shown. Ceramic cubes **130** preferably comprise a rigid abrasion-resistant material, preferably a monolithic block of hard ceramic, as shown. Ceramic cubes **130** preferably comprise outer dimensions of about one and one-half-inch square by about one-inch thick. Preferably, each respective ceramic cube **130** comprise a spacer, to assist arrangement as a continuous layer of ceramic by abutting the ceramic cubes **130** into ceramic-rubber wear layer **125** (at least embodying herein wherein such replaceable surface means comprises wear-resister element means for resisting wear of such replaceable surface means when handling the abrasive material; and, at least embodying herein wherein such at least one replaceable surface comprises at least one wear-resister element structured and arranged to resist wear of such at least one replaceable surface) and preferably leave room around such ceramic cubes for rubber encapsulation to hold ceramic-rubber wear layer **125** together, as shown and described herein.

Further, while rubber is the preferred encapsulate, upon reading this specification, those with ordinary skill in the art will now appreciate that, under appropriate circumstances, considering such issues as design preference, user preferences, marketing preferences, cost, structural requirements, available materials, technological advances, etc., other encapsulate materials such as, for example, polyurethane, carbon-fiber compositions, other elastomeric compositions, etc., may suffice.

The plurality of ceramic cubes **130** preferably are fully encased in elastomeric material, preferably an integral matrix, preferably rubber **140**, as shown. Magnetic coupling element(s) **120** are preferably embedded within rubber **140**, as shown.

Magnetic coupling element(s) **120** are preferably embedded within rubber **140** to a degree sufficient to permanently attach the magnetic coupling element(s) with the ceramic reinforced rubber wear layer **125**. This preferred arrangement at least embodies herein wherein such at least one replaceable surface comprises

at least one magnet structured and arranged to magnetically attach such at least one replaceable surface to the abrasive-material handling-equipment; and, this arrangement at least embodies herein wherein such at least one magnet comprises at least one permanent attacher structured and arranged to permanently attach with such at least one replaceable surface; and, further this arrangement at least embodies herein wherein such replaceable surface means comprises magnet means for magnetically attaching such replaceable surface means to the equipment handling abrasive material; and, this arrangement embodies herein wherein such magnet means comprises permanent attacher means for permanently attaching with such replaceable surface means; and, this arrangement embodies herein. Upon reading this specification, those with ordinary skill in the art will now appreciate that, under appropriate circumstances, considering such issues as design preference, user preferences, marketing preferences, cost, structural requirements, available materials, technological advances, etc., other integral matrix arrangements such as, for example, polyurethane, rubber-mix compounds, plastic, carbon-fiber, metal, ceramic, etc., may suffice.

Preferably, before molding/encasing with rubber takes place, metal bottom portion **110** preferably is prepared by degreasing, sandblasting, or shot blasting in order to completely free the surface from rust and other impurities. A bonding agent is then preferably applied to specific areas of both the bottom portion **110** and magnetic coupling element(s) **120**. In preferred embodiments of the liner systems **100**, ceramic cubes **130** are also treated with an adhesion-enhancing primer. The rubber is then placed into the mold for forming and curing with sufficient heat and pressure (for example, steam supplied heat and hydraulic pressures upwards of about 1600 tons) to integrally bond and form a single matrix of rubber encased bottom portion **110**, magnetic coupling element(s) **120**, and ceramic cubes **130** thereby forming liner panel **102**, as shown.

WO 2011/091310

PCT/US2011/022134

Preferably, rubber **140** is pressed into place over first the magnetic coupling element(s) **120** and then, over the plurality of ceramic cubes **130** to form a magnetically-attachable integral liner panel **102**, as shown (this arrangement at least
5 embodies herein wherein such at least one permanent attacher comprises a single integral-matrix bond structured and arranged to integrally-matrix bond such at least one magnet with such at least one replaceable surface; and, this arrangement at least
10 embodies herein wherein such permanent attacher means comprises integral-matrix bond means for integral-matrix bonding of such magnet means with such replaceable surface means). Those with ordinary skill in the art will now appreciate that upon reading this specification and by their understanding the art of rubber attachment as described herein, methods of encasing in an
15 integral matrix will be understood by those knowledgeable in such art.

In use, at least one or more liner panels **102** are magnetically coupled to, and installed along, the container portion **103** of a heavy hauler truck bed **104** (this arrangement at
20 least embodies herein wherein such at least one vehicle comprises at least one container portion structured and arranged to contain the abrasive material), large-bed vehicle equipment **112** (or other user-preferred device) preferably by magnetic coupling element(s) **120** attaching to the heavy hauler truck bed
25 which preferably comprises a ferromagnetic surface **117** (at least embodying herein at least one vehicle, having at least one ferromagnetic surface, structured and arranged to handle abrasive material), preferably steel or other magnetic-attraction material. Preferably, liner panels **102** are custom-
30 fitted to each specific equipment dimension so as to tightly assemble in place when installed, as shown. As custom-fitting of liner panel system **100** is preferred, the exact equipment size surface area to be lined is preferably provided prior to manufacture of the liner panel system **100** to be installed on the
35 particular vehicle or processing equipment.

WO 2011/091310

PCT/US2011/022134

Preferably, during installation, the magnetic polarity of each respective magnetic coupling element(s) **120** is oriented to assist adjacent liner panels **102** to "pull" toward each other rather than away from each other, as shown (See FIG. 1B and FIG. 4); as such, thereby increasing the overall magnetic attachment of the liner panel **102** to the truck bed (or other such equipment surface, as shown. Material flow **150** is preferably across (perpendicular to) the aligned polarity of liner panels **102**, as shown. Preferably, liner panels **102** are installed in such manner to have the material flow across the aligned polarity of liner panels **102**, as shown.

Depending on the use of the liner panel **102**, a wear layer **125** comprising a rubber thickness of between about one inch and about twelve inches may be placed over the ceramic cubes **130**. As stated above, liner panel **102** dimensions are preferably customized to a specific truck bed arrangement and may vary widely depending on application, etc. Individual panel sizes preferably range in square or rectangular pattern from about 1.5 feet by 1.5 feet to about 3 feet by 4 feet. Upon reading this specification, those with ordinary skill in the art will now appreciate that, under appropriate circumstances, considering such issues as design preference, user preferences, marketing preferences, cost, structural requirements, available materials, technological advances, etc., other dimension arrangements such as, for example, larger or smaller, other geometric arrangement, trapezoidal, triangular, etc., may suffice.

Preferably, for example, a liner panel **102** having a rectangular size of about 16 inches square would preferably comprise six ceramic magnetic coupling units **120** (at least embodying herein wherein such plurality of magnets comprises at least six ceramic magnets structured and arranged in at least one aligned polarity so as to increase the magnetic attaching of such at least one replaceable surface to the abrasive-material handling-equipment). Preferably, each respective ceramic magnetic coupling units **120** is approximately one-inch thick,

WO 2011/091310

PCT/US2011/022134

four-inches wide, and six-inches long, preferably situate in aperture portions 132 and placed about one-inch inward from the perimeter of the liner panel **102**, as shown. Preferably, ceramic magnetic coupling units **120** are arranged with north-south polarity, as shown. In the example arrangement above, Applicant has measured an average magnetic field of at least about 0.812 Kilogauss. Preferably, the magnetic field (holding power) of liner panel **102** is about one kilogauss averaged. Upon reading this specification, those with ordinary skill in the art will now appreciate that, under appropriate circumstances, considering such issues as design preference, user preferences, marketing preferences, cost, structural requirements, available materials, technological advances, etc., other magnetic field arrangements such as, for example, those determined by the use, ferromagnetic material content of the applicable surface, magnetic material, etc., may suffice.

FIG. 4 shows a top view, partially in section, illustrating another liner panel **202** of the liner systems **100**, according to a preferred embodiment of the present invention. FIG. 5 shows an end section view, of the liner panel **202** according to the preferred embodiment of FIG. 5.

Liner panel **202** preferably comprises another preferred magnetic liner panel arrangement for lining of a heavy hauler truck bed, large-bed vehicle equipment **112** (or other user-preferred device) preferably by magnetic coupling element(s) **220** attaching to the heavy hauler truck bed which preferably comprises steel or other magnetically-attachable material. Liner panel **202** preferably comprises at least one frame **205**, preferably steel, preferably comprising a bottom portion **210**, side portions **215** and a top portion **209**. Bottom portion **210** (the side that couples to the vehicle/device) preferably comprises at least one, and preferably multiple, "punch-out" aperture portions **232** (the side that couples to the vehicle/device) within which periphery magnetic coupling element(s) **220** is/are placed, as shown.

Liner panel **202** preferably comprises at least one wear layer **225**, preferably placed parallel to the bottom portion **210** and above plurality of ceramic cubes **230**, as shown. Preferably, wear layer **225** comprises a layer of ceramic, preferably a plurality of ceramic cubes **230**, as shown. Preferably, magnetic coupling element(s) **220** and the plurality of ceramic cubes **230** are fully encased in rubber. Preferably, rubber **240** is pressed into place over first the magnetic coupling element(s) **220** and then, over the plurality of ceramic cubes **230**, to form a magnetically-attachable integral liner panel **202** as shown. Those with ordinary skill in the art will now appreciate that upon reading this specification and by their understanding the art of rubber encasement as described herein, methods of pressing and heating such rubber for rubber encasing will be understood by those knowledgeable in such art.

In use, at least one or more liner panels **202** are installed along the interior portion of a heavy hauler truck bed (or other user-preferred device). Preferably, the liner panels **202** are custom-fitted to each specific equipment dimension so as to tightly assemble in place when installed. Preferably, the magnetic polarity of each respective magnetic coupling element(s) **220** is placed to assist adjacent liner panels **202** to "pull" toward each other rather than away from each other thereby increasing the overall magnetic attachment of the liner panel **202** to the truck bed (or other such equipment surface); furthermore, material flow **250** is preferably across the polarity of the liner panels **202**, as shown. Depending on the use of the liner panel **202**, a wear layer **225** comprising a rubber thickness of between about one inch and about twelve inches may be placed over the ceramic cubes **230**, as shown.

Although applicant has described applicant's preferred embodiments of this invention, it will be understood that the broadest scope of this invention includes modifications such as diverse shapes, sizes, and materials. Such scope is limited only by the below claims as read in connection with the above

WO 2011/091310

PCT/US2011/022134

specification. Further, many other advantages of applicant's invention will be apparent to those skilled in the art from the above descriptions and the below claims.

CLAIMS:

1. A system, relating to providing replaceable wear surfaces on abrasive-material handling-equipment, comprising:

a) at least one replaceable surface structured and arranged to provide at least one replaceable surface onto the abrasive- material handling-equipment;

b) wherein said at least one replaceable surface comprises at least one wear-resister element structured and arranged to resist wear of said at least one replaceable surface;

c) wherein said at least one replaceable surface comprises at least one magnet structured and arranged to magnetically attach said at least one replaceable surface to the abrasive-material handling-equipment; and

d) wherein said at least one magnet comprises at least one permanent attacher structured and arranged to permanently attach with said at least one replaceable surface.

2. The system according to claim 1 wherein said at least one permanent attacher comprises a single integral-matrix bond structured and arranged to integrally-matrix bond said at least one magnet with said at least one replaceable surface.

3. The system according to claim 1 wherein said at least one wear-resister element comprises at least one ceramic element structured and arranged to increase wearability of said at least one replaceable surface.

4. The system according to claim 1 further comprising:
 - a) at least one vehicle, having at least one ferromagnetic surface, structured and arranged to handle abrasive material;
 - b) wherein said at least one vehicle comprises at least one container portion structured and arranged to contain the abrasive material;
 - c) wherein said at least one container portion comprises such at least one ferromagnetic surface; and
 - d) wherein said at least one container portion comprises at least one of said replaceable wear surface magnetically attached to such at least one ferromagnetic surface.

5. The system according to claim 2 wherein said integral-matrix bond comprises at least one elastomeric material.

6. The system according to claim 2 wherein said integral-matrix bond comprises rubber.

7. The system according to claim 5 wherein said at least one elastomeric material comprises rubber.

8. The system according to claim 1 wherein said at least one magnet comprises a plurality of magnets.

9. The system according to claim 8 wherein said plurality of magnets comprises a plurality of ceramic magnets.

10. The system according to claim 9 wherein said plurality of magnets comprises at least six ceramic magnets structured and arranged in at least one aligned polarity so as to increase the magnetic attaching of said at least one replaceable surface to the abrasive-material handling-equipment.

11. The system according to claim 3 wherein said wear-resistant element comprises a rubber thickness of between about one inch and about twelve inches.

12. The system according to claim 9 wherein:

a) said plurality of magnets is situate opposite at least one ceramic element.

13. The system according to claim 9 further comprising:

a) at least one vehicle, having at least one ferromagnetic surface, structured and arranged to handle abrasive material;

b) wherein said at least one vehicle comprises at least one container portion structured and arranged to contain the abrasive material;

c) wherein said at least one container portion comprises such at least one ferromagnetic surface; and

d) wherein said at least one container portion comprises at least one of said replaceable wear surface magnetically attached to such at least one ferromagnetic surface.

14. A system, relating to providing replaceable wear surfaces on abrasive-material handling-equipment, comprising:

a) replaceable surface means for providing at least one replaceable surface;

b) wherein said replaceable surface means comprises wear-resister element means for resisting wear of said replaceable surface means when handling the abrasive material;

c) wherein said replaceable surface means comprises magnet means for magnetically attaching said replaceable surface means to the equipment handling abrasive material; and

d) wherein said magnet means comprises permanent attacher means for permanently attaching with said replaceable surface means.

15. The system according to claim 14 wherein said permanent attacher means comprises integral-matrix bond means for integral-matrix bonding of said magnet means with said replaceable surface means.

16. The system according to claim 14 wherein said wear-resister element means comprises ceramic element means for increasing wearability of said replaceable surface means.

17. The system according to claim 3 wherein:

a) said integral-matrix bond comprises rubber; and

b) said at least one magnet comprises a plurality of ceramic magnets.

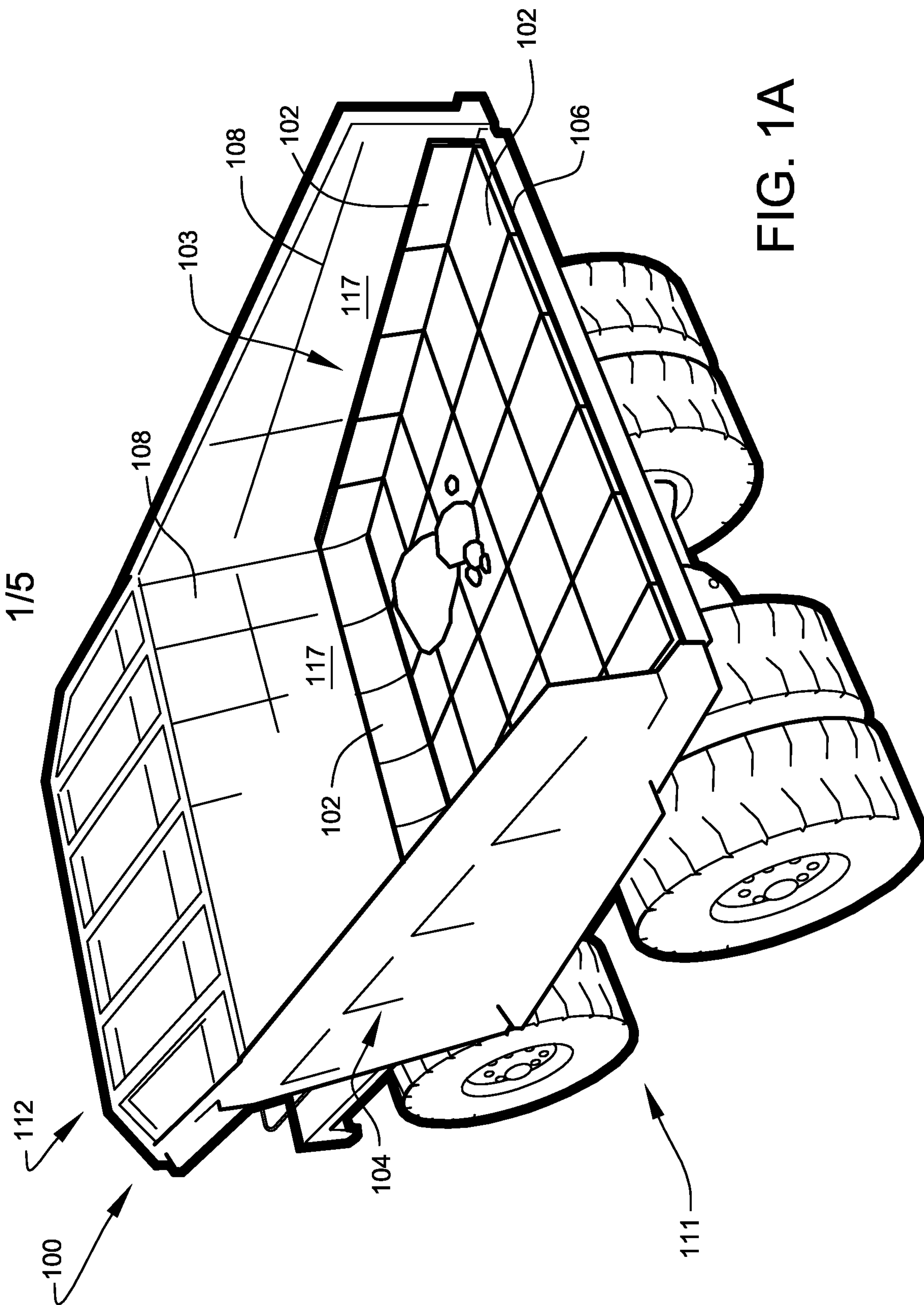

FIG. 1A

2/5

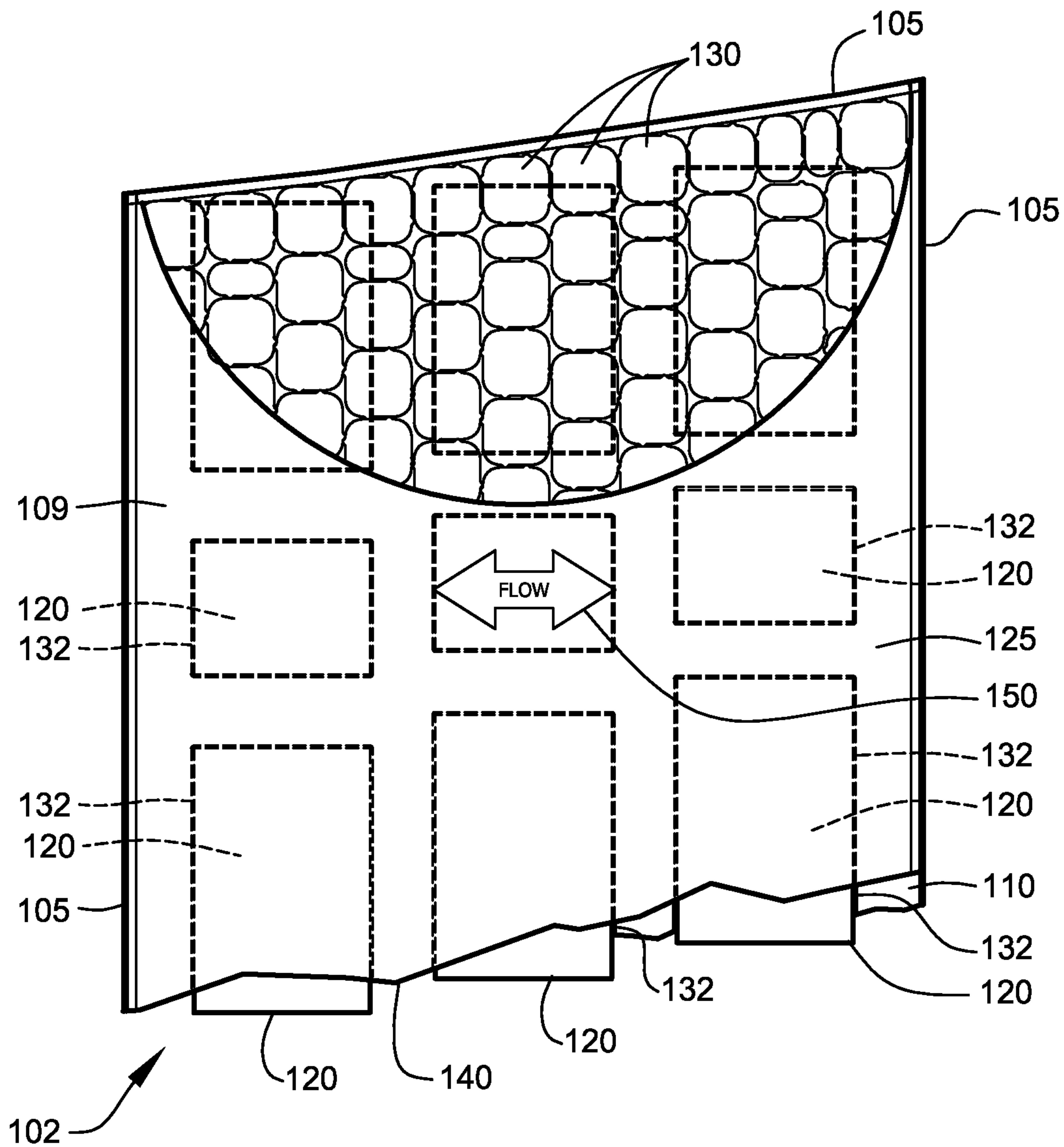

FIG. 1B

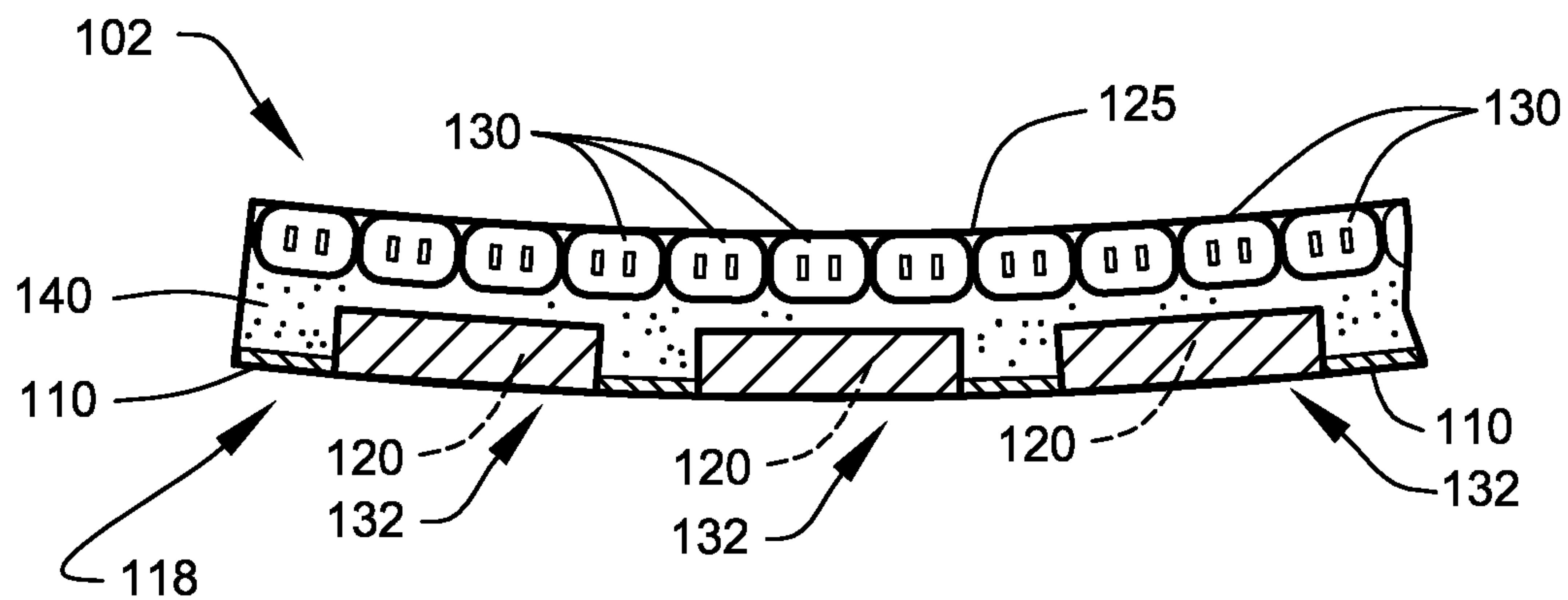

FIG. 2

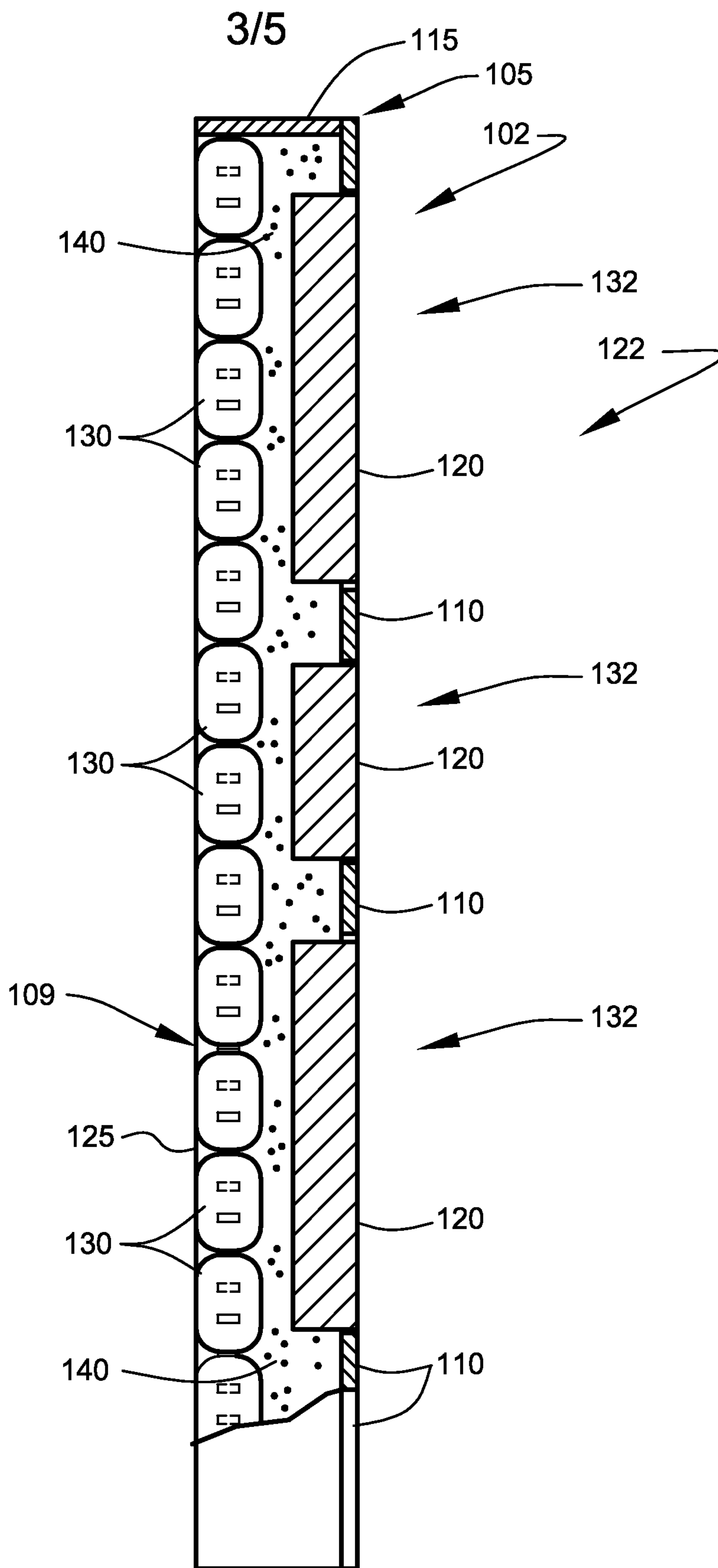

FIG. 3

4/5

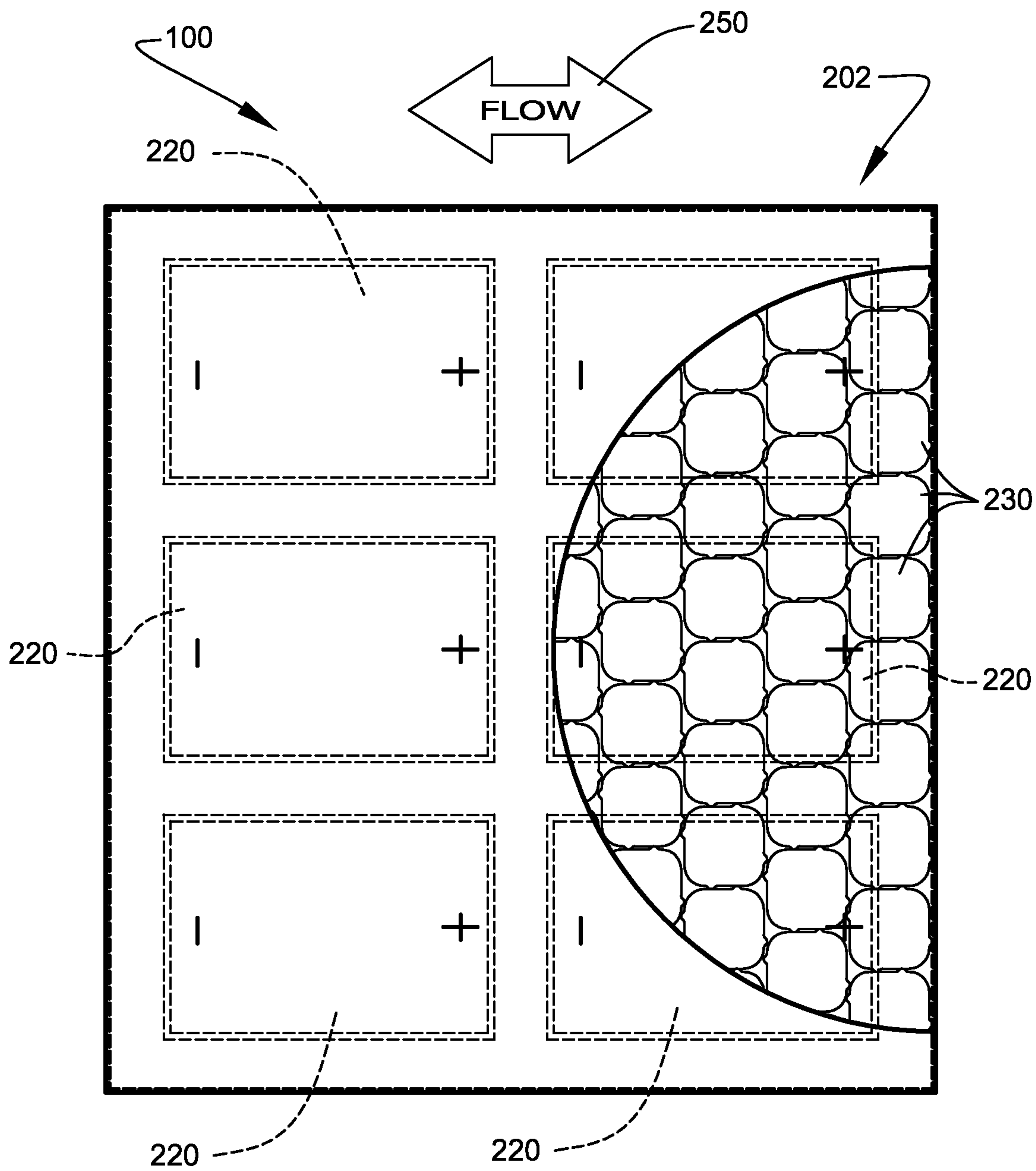

FIG. 4

5/5

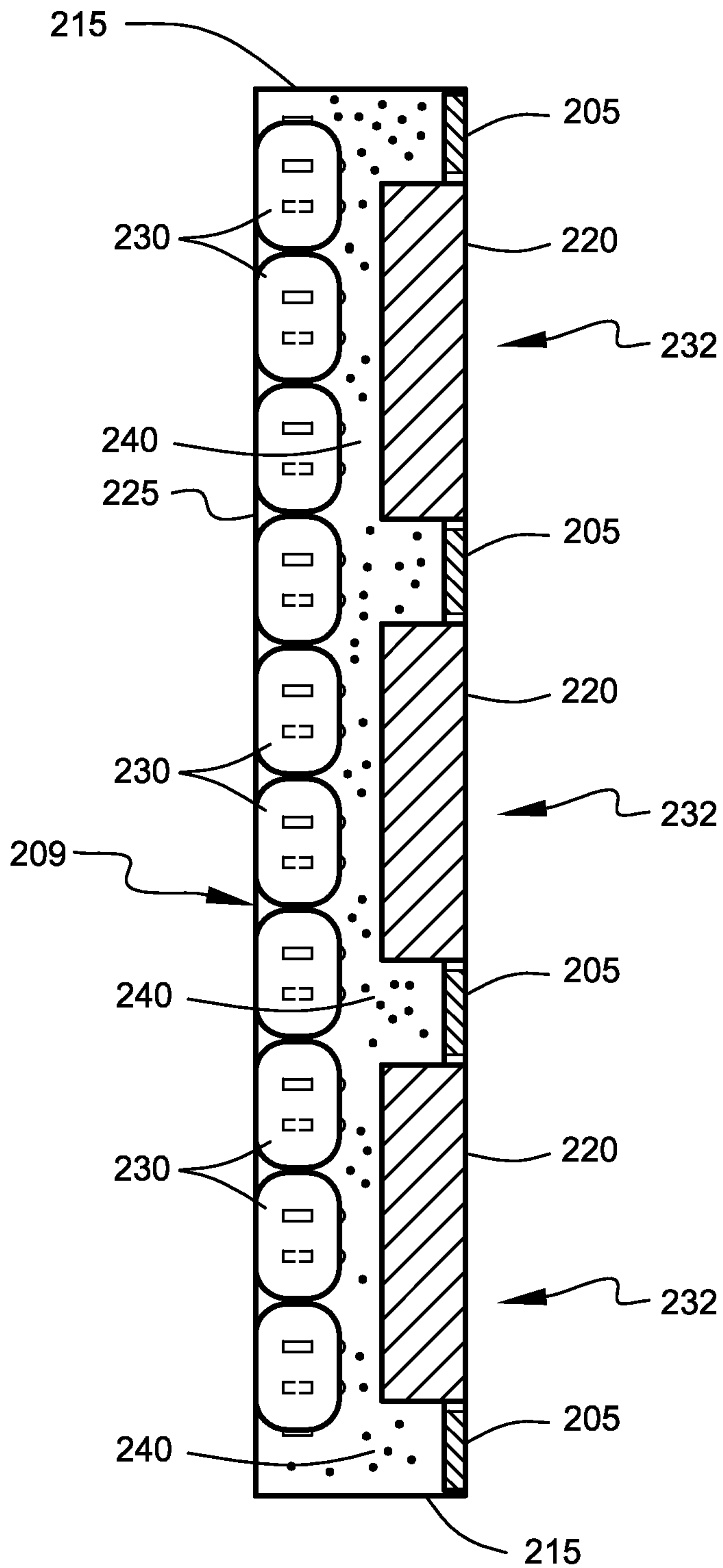
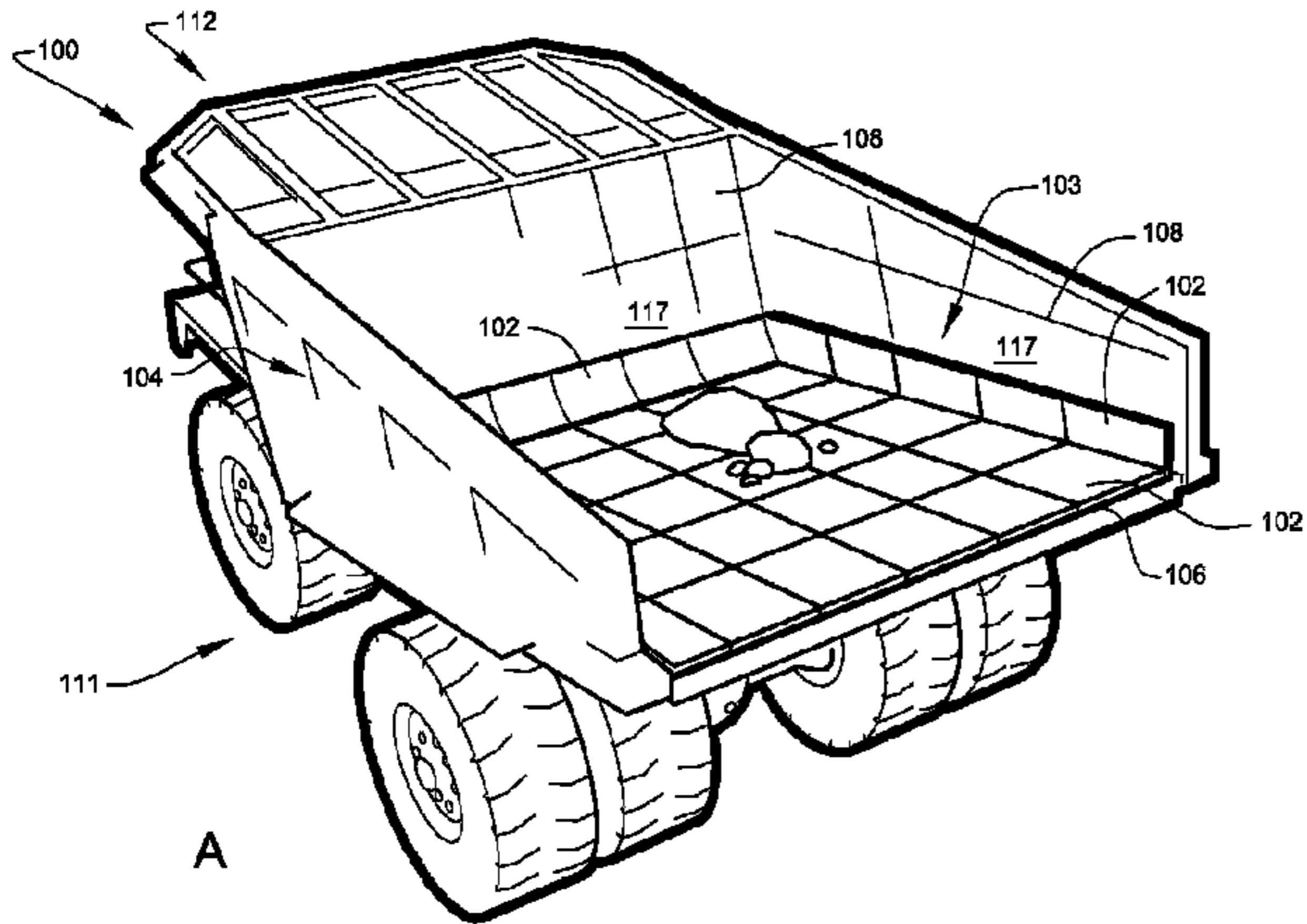
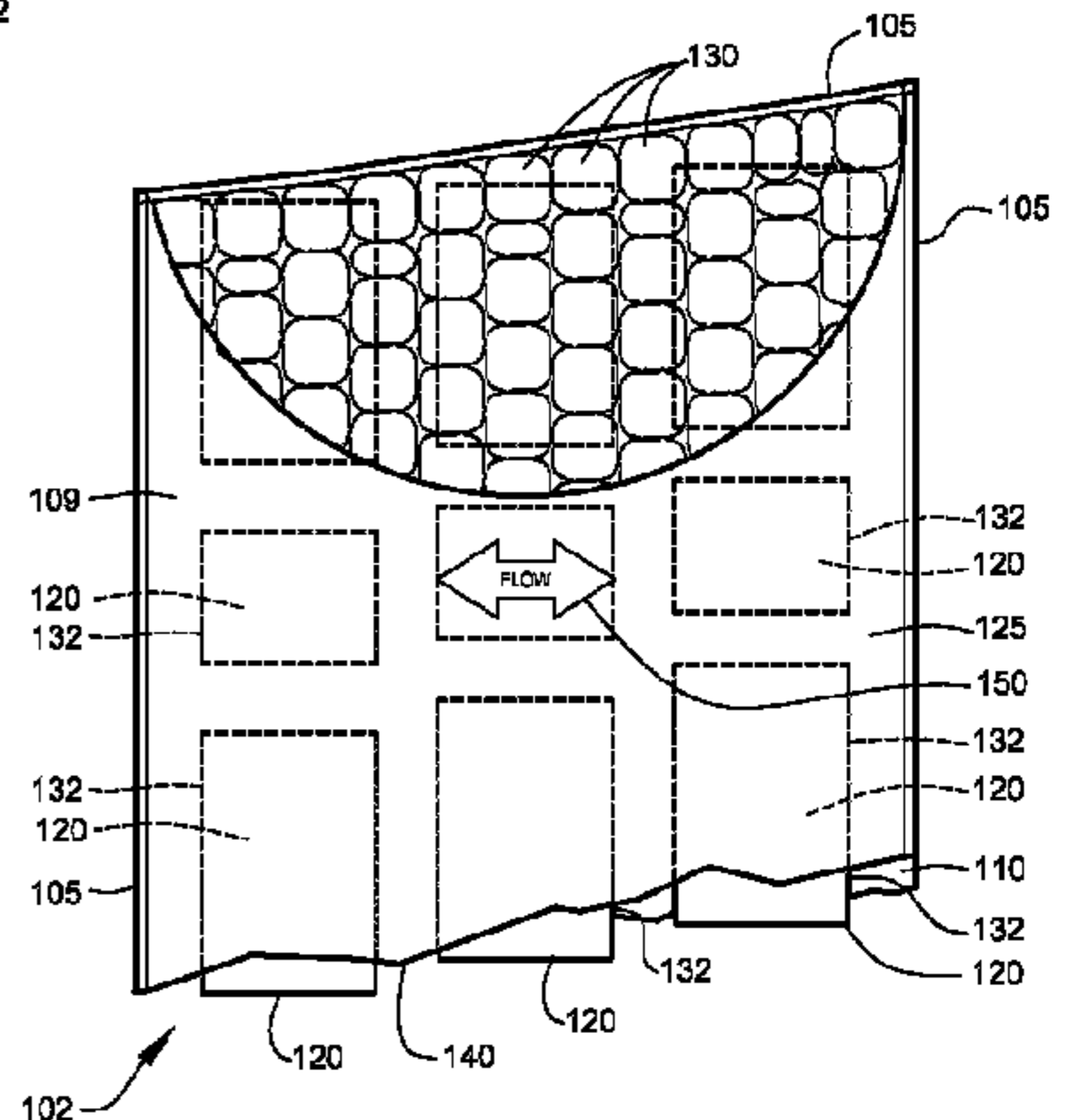

FIG. 5



A



B