

(19) World Intellectual Property Organization
International Bureau



(43) International Publication Date
15 July 2010 (15.07.2010)

PCT

(10) International Publication Number
WO 2010/080879 A2

(51) International Patent Classification:
A61N 2/02 (2006.01) A61B 5/055 (2006.01)
A61B 5/05 (2006.01)

(74) Agents: SHOOP, Richard, D. et al.; Shay Glenn LLP,
2755 Campus Drive, Suite 210, San Mateo, CA 94403
(US).

(21) International Application Number:
PCT/US2010/020324

(81) Designated States (unless otherwise indicated, for every
kind of national protection available): AE, AG, AL, AM,
AO, AT, AU, AZ, BA, BB, BG, BH, BR, BW, BY, BZ,
CA, CH, CL, CN, CO, CR, CU, CZ, DE, DK, DM, DO,
DZ, EC, EE, EG, ES, FI, GB, GD, GE, GH, GM, GT,
HN, HR, HU, ID, IL, IN, IS, JP, KE, KG, KM, KN, KP,
KR, KZ, LA, LC, LK, LR, LS, LT, LU, LY, MA, MD,
ME, MG, MK, MN, MW, MX, MY, MZ, NA, NG, NI,
NO, NZ, OM, PE, PG, PH, PL, PT, RO, RS, RU, SC, SD,
SE, SG, SK, SL, SM, ST, SV, SY, TH, TJ, TM, TN, TR,
TT, TZ, UA, UG, US, UZ, VC, VN, ZA, ZM, ZW.

(22) International Filing Date:
7 January 2010 (07.01.2010)

(25) Filing Language: English

(26) Publication Language: English

(30) Priority Data:
61/143,103 7 January 2009 (07.01.2009) US

(71) Applicant (for all designated States except US):
NEOSTIM, INC. [US/US]; 951 Mariner's Island Blvd.,
Suite 300, San Mateo, CA 94404 (US).

(84) Designated States (unless otherwise indicated, for every
kind of regional protection available): ARIPO (BW, GH,
GM, KE, LS, MW, MZ, NA, SD, SL, SZ, TZ, UG, ZM,
ZW), Eurasian (AM, AZ, BY, KG, KZ, MD, RU, TJ,
TM), European (AT, BE, BG, CH, CY, CZ, DE, DK, EE,
ES, FI, FR, GB, GR, HR, HU, IE, IS, IT, LT, LU, LV,
MC, MK, MT, NL, NO, PL, PT, RO, SE, SI, SK, SM,
TR), OAPI (BF, BJ, CF, CG, CI, CM, GA, GN, GQ, GW,
ML, MR, NE, SN, TD, TG).

(72) Inventors; and

(75) Inventors/Applicants (for US only): MISHELEVICH,
David, J. [US/US]; 951 Mariner's Island Blvd., Suite
300, San Mateo, CA 94404 (US). SCHNEIDER, M.,
Bret [US/US]; 951 Mariner's Island Blvd., Suite 300, San
Mateo, CA 94404 (US).

[Continued on next page]

(54) Title: SHAPED COILS FOR TRANSCRANIAL MAGNETIC STIMULATION

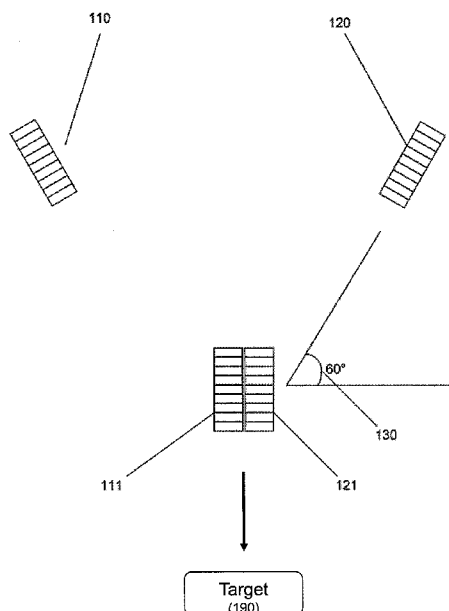

FIG. 1

(57) Abstract: Described herein are shaped coil TMS electromagnets formed by two bent magnetic coil loops joined at a vertex having an angle between the outer coil regions of the coils that is typically less than 120 degrees (e.g., between about 45 and about 70 degrees, 60 degrees, etc.). The vertex region shaped to optimize the magnetic field projected from the TMS electromagnet. For example, the vertex region may be horizontal or vertical. In some variations the vertex region is formed by re-arranging the conductive windings forming the two coils so that they are no longer arranged in the same columnar structure that they are in the other portions of the bent magnetic coil loops. These TMS electromagnets may be well suited for use in deep-brain Transcranial Magnetic Stimulation.

WO 2010/080879 A2

Published:

- *without international search report and to be republished upon receipt of that report (Rule 48.2(g))*

SHAPED COILS FOR TRANSCRANIAL MAGNETIC STIMULATION**CROSS REFERENCE TO RELATED APPLICATIONS**

[0001] This application claims priority to U.S. Provisional patent application Serial No. 5 61/143,103, titled "SHAPED COILS FOR TRANSCRANIAL MAGNETIC STIMULATION", filed on January 7, 2009.

INCORPORATION BY REFERENCE

[0002] All publications and patent applications mentioned in this specification are herein 10 incorporated by reference in their entirety to the same extent as if each individual publication or patent application was specifically and individually indicated to be incorporated by reference.

FIELD OF THE INVENTION

[0003] The devices and methods described herein relate generally to the focusing of magnetic fields generated by electromagnets used for Transcranial Magnetic Stimulation (TMS). 15 In particular, shaped coil pairs that are advantageous for TMS are described.

BACKGROUND OF THE INVENTION

[0004] A typical Transcranial Magnetic Stimulation (TMS) electromagnet includes a pair of coils that are joined to form a flat figure-8 shaped electromagnet. Such figure-eight double coil magnets are well known, for instance the 70 mm double-coil configuration from Magstim 20 (e.g., Model 9925, Magstim Ltd., Wales, UK). The electromagnets can be powered by commercially available power sources such as the "Magstim Rapid²" (Magstim Ltd., Wales, UK) that provides electrical currents for pulsed magnetic fields. The magnetic field projected from standard figure-8 shaped double coil electromagnets is not optimal for deep brain stimulation, however. In particular, the depth and shape of the emitted field is limited.

25 [0005] For conventional circular and double circular coils, the *Biot-Savart* law dictates that magnetic field strength declines as a function of distance from face of a coil. This makes focal stimulation of the brain challenging to achieve at the cortical surface (beneath scalp, skull and meninges), and even more difficult beneath the cortical surface.

[0006] Alternative configurations for TMS electromagnets have been proposed, 30 including those described in Zangen et al. (US Patent applications publication numbers 2006/0287566 and 2004/0078056). Alternative designs have likewise been proposed in Levkovitz Y, Roth Y, Harel EV, Braw Y, Sheer A, Zangen A, "A randomized controlled

feasibility and safety study of deep transcranial magnetic stimulation.” Clin. Neurophysiol. 118(12):2730-44 (Dec 2007).

[0007] However, the proposed designs described above each have substantial disadvantages, particularly with regard to the specificity and control of the magnetic field generated, as well as the ease with which these magnets may be fabricated and characterized. Described herein are TMS electromagnets configured to address many of the problems described above. In particular, the inventors have found that, unexpectedly, TMS electromagnets formed from coils that are not linear, but are instead curved or bent to form a “V”, “U” or “Y” may result in magnetic field intensities that are well suited for deep-brain TMS.

[0008] The coils described herein for TMS may therefore be designed to accommodate a difficult balance between focality, and power level delivered to a target. This balance has been particularly difficult to achieve with known TMS electromagnets, yet is of great importance when the target is below the cortical surface of the brain.

[0009] Examples of systems, devices and methods that may benefit from the TMS coils

described herein may be found, for example, in any of the following applications: Patent Application No. PCT/US2008/071663, (titled “DEVICE AND METHOD FOR TREATING HYPERTENSION VIA NON-INVASIVE NEUROMODULATION”) filed 7/30/2008; Patent Application No. PCT/US2008/072930, (titled “GANTRY AND SWITCHES FOR POSITION-BASED TRIGGERING OF TMS PULSES IN MOVING COILS”) filed 8/12/2008; Patent Application No. PCT/US2008/073751, (titled “FIRING PATTERNS FOR DEEP BRAIN TRANSCRANIAL MAGNETIC STIMULATION”), filed 8/20/2008; Patent Application No. PCT/US2008/075575 (titled “FOCUSING MAGNETIC FIELDS WITH ATTRACTOR MAGNETS AND CONCENTRATOR DEVICES”), filed 9/8/2008; Patent Application No. PCT/US2008/075583 (titled “PITCH, ROLL, AND YAW MOTIONS FOR ELECTROMAGNET ARRAYS”), filed 9/8/2008; Patent Application No. PCT/US2008/075706 (titled “FOCUSED MAGNETIC FIELDS”), filed 9/9/2008; Patent Application No. PCT/US2008/075824 (titled “AUTOMATED MOVEMENT OF ELECTROMAGNETS TRACKING ECCENTRICITY OF THE HEAD”), filed 9/10/2008; Patent Application No. PCT/US2008/077851 (titled “SYSTEMS AND METHODS FOR COOLING ELECTROMAGNETS FOR TRANSCRANIAL MAGNETIC STIMULATION”), filed 9/26/2008; Patent Application No. PCT/US2008/079378 (titled “DISPLAY OF MODELED MAGNETIC FIELDS”), filed 10/9/2008; Patent Application No. PCT/US2008/081048 (titled “INTRA-SESSION CONTROL OF TRANSCRANIAL MAGNETIC STIMULATION”), filed 10/24/2008; Patent Application No. PCT/US2008/081307 (titled “TRANSCRANIAL MAGNETIC STIMULATION WITH PROTECTION OF MAGNET-ADJACENT

STRUCTURES”), filed 10/27/2008; US Patent Application Serial No. 12/324,227 (titled “TRANSCRANIAL MAGNETIC STIMULATION OF DEEP BRAIN TARGETS”), filed 11/26/2008; US Patent Application Serial No. 12/185,544 (titled “MONOPHASIC MULTI-COIL ARRAYS FOR TRANSCRANIAL MAGNETIC STIMULATION”), filed 8/4/2008; and
5 Patent Application No. PCT/US2008/072154 (titled “MONOPHASIC MULTI-COIL ARRAYS FOR TRANSCRANIAL MAGNETIC STIMULATION”), filed 8/4/2008.

SUMMARY OF THE INVENTION

[00010] The present invention provides an improved design for magnetic brain stimulation coils. This coil design (generally referred to as a “V-shaped coil” may yield a substantially
10 improved penetration to depth. In particular the “I-bottomed V-shaped coils” (also referred to as the Y-shaped coils) are of particular interest, and have been found to have unexpectedly superior magnetic field profiles for use in TMS.

[00011] For example, described herein are Y-shaped Transcranial Magnetic Stimulation (TMS) electromagnets configured to emit a focused magnetic field. These TMS electromagnets
15 may include: a first bent magnetic coil loop comprising a plurality of windings and a second bent magnetic coil loop comprising a plurality of windings; wherein the first magnetic coil loop comprises a first inner coil region and the second magnetic coil loop comprises a second inner coil region, and wherein the first and second inner coil regions are arranged to form a vertex configured so that the plurality of windings within the first inner coil region for a column this is
20 adjacent and parallel to the plurality of windings within the second inner coil that are arranged in a column; and wherein the first magnetic coil loop comprises a first outer coil region and the second magnetic coil loop comprises a second outer coil region, and the angle between the first outer coil region and the second outer coil region is between about 30 degrees and about 120 degrees.

25 [00012] The first outer coil region may be located opposite the first inner coil region on the first magnetic coil loop and wherein the second outer coil region is opposite the second inner coil region on the second magnetic coil loop.

[00013] In some variations, the first bent magnetic coil loop comprises greater than 5 windings. In some variations, the angle between the first outer coil region and the second outer
30 coil region is approximately 60 degrees.

[00014] The TMS electromagnet may also include a structural support matrix surrounding the first and second bent magnetic coil loops.

[00015] The first and second bent magnetic coil loops may be electrically connected so that the current flows from the first coil loop into the second coil loop. Further, the vertex is

configured so that current will flow in the same direction in the first and second inner coil regions of the vertex.

5 [00016] The first and second bent magnetic coil loops may be arranged symmetrically about the vertex. The first and second bent magnetic coil loops may have approximately the same shape and size, or they may be different sizes.

10 [00017] Also described herein are shaped coil Transcranial Magnetic Stimulation (TMS) electromagnet comprising: a first bent magnetic coil loop comprising a column formed of a plurality of conductive windings; a second bent magnetic coil loop comprising a column formed of a plurality of conductive windings; and a vertex region connecting the first and second bent magnetic coil loops; wherein the vertex region is formed by aligning the columns of conductive windings within the first bent magnetic coil loop in parallel with the column of conductive windings within the second bent magnetic coil loop; wherein the angle between a first outer coil region of the first magnetic coil loop and a second outer coil region of the second magnetic coil loop is less than 120 degrees.

15 [00018] The vertex region may comprise an interleaved vertex, as described in greater detail below, or the vertex region may comprise an I-bottomed vertex (the I-bottomed vertex may be considered a sub-set of the interleaved vertex).

20 [00019] The first outer coil region may be the region of the coil(s) opposite the vertex region on the first magnetic coil loop and wherein the second outer coil region is opposite the vertex region on the second magnetic coil loop.

[00020] The first magnetic coil loop may comprise greater than 5 windings.

[00021] In some variations the angle between a first outer coil region of the first magnetic coil loop and a second outer coil region of the second magnetic coil loop is approximately 60 degrees.

25 [00022] As mentioned, the shaped TMS electromagnet may further comprising a structural support matrix surrounding the first and second magnetic coil loops.

30 [00023] The first and second bent magnetic coil loops may be electrically connected so that the current flows from the first bent magnetic coil loop into the second bent magnetic coil loop. Further, the vertex may be configured so that current will flow in the same direction in the portion of the windings forming the first and second bent magnetic coil loops that are part of the vertex.

35 [00024] Also described herein are shaped coil Transcranial Magnetic Stimulation (TMS) electromagnets comprising: a first bent magnetic coil loop comprising a plurality of conductive windings; a second bent magnetic coil loop comprising a plurality of conductive windings; and a generally V-shaped bottom vertex region between the first and second bent magnetic coil loops;

wherein the angle between an outer coil region of the first bent magnetic coil loop and the outer coil region of the second bent magnetic coil loop is between about 55 and about 65 degrees; and wherein the V-shaped bottom vertex region is formed by arranging immediately adjacent portions of the each coil at an angle of between about 70 and about 110 degrees relative to each other.

[00025] Also described herein are shaped Transcranial Magnetic Stimulation (TMS) electromagnet comprising: a first bent magnetic coil loop formed of a column comprising a plurality of windings; a second bent magnetic coil loop formed of a column comprising a plurality of windings; a flat-bottomed vertex region between the first and second bent magnetic coil loops; wherein the angle between an outer coil region of the first bent magnetic coil loop and the outer coil region of the second bent magnetic coil loop is between about 55 and about 65 degrees; and wherein the flat-bottom vertex region is formed by arranging an inner coil region of the first bent magnetic coil loop immediately adjacent to an inner coil region of the second bent magnetic coil loop so that the column of windings forming the first and second inner coil regions are at an angle of approximately 180 degrees with respect to each other.

BRIEF DESCRIPTION OF THE DRAWINGS

[00026] FIG. 1 shows a cross-section through a TMS electromagnet having a pair of coils oriented in a “Y” configuration, also referred to as an “I-bottomed V-shaped coil pair”.

[00027] FIG. 2A shows a partial cross-section through a TMS electromagnet having a pair of coils oriented in a “U” configuration, also referred to as a “flat-bottomed V-shaped coil pair”.

[00028] FIG. 2B is a cross-section through a flat-bottomed V-shaped coil pair (or “U”-shaped coil pair).

[00029] FIG. 2C is a cross-section through a V-shaped coil pair.

[00030] FIG. 2D is a cross-section through an I-bottomed V-shaped coil pair (or “Y”-shaped coil pair).

[00031] FIG. 2E is a cross-section through another V-shaped coil pair having a central section that is maximized for contact between the central members of the coils.

[00032] FIG. 2F is a cross-section through another V-shaped coil pair having a central section that is maximized for contact between the central members of the coils.

[00033] FIG. 3A through 3C show different perspective views of one variation (shown here as a mock-up model) of an I-bottomed V-shaped coil pair.

[00034] FIG. 4 is one example of a TMS electromagnet as described herein.

DETAILED DESCRIPTION

[00035] In general, the TMS magnets described herein may be referred to as shaped-coil TMS magnets. A shaped-coil TMS magnet typically includes a pair of coils (each having multiple windings) that have a non-flat shape and are connected to each other at a vertex region or point. A shaped coil may have a bent or curved ring shape. The shaped coils described herein may also be referred to as “V-shaped” coils.

[00036] Prior art TMS magnets having a two coils were typically “flat,” forming a “figure-8” shape. The shaped-coil TMS magnets described herein generally have two coils that are at an angle with each other that is less than 180 degrees (an angle of 180 degrees corresponds to the standard “figure-8” shaped coils), and an angle with respect to a horizontal plane that is greater than zero (e.g., a standard “figure-8” shaped coil has an angle of 0 degrees with respect to the horizontal). The vertex region, which may also be referred to as the ‘bottom’ of the shaped coil pairs, may be flat (e.g., the coils are connected end-to-end with a local angle relative to each other of 180°), parallel (e.g., the coils are connected so that the stack of windings for each coil are parallel with the stack of windings of the other coil), V-shaped (e.g., the stack of windings for each coil are angled with respect to each other), or intermingled/interleaved (e.g., the windings of each coil overlap with each other). From the vertex region, both coils typically extend outwards, subtending an angle that is less than 180 degrees. The “angle” of the TMS electromagnet may refer to the angle by which the coils are bent from the horizontal, starting from the standard figure-8 coil configuration. As illustrated below, the angle of the TMS electromagnet may be varied, but in some variations the minimum angle between the outermost portions of the rings is approximately 60 degrees.

[00037] The two coils are typically in electrical continuity, so that the windings of one coil are continuous with the windings of the other coil. Coils are typically wound in opposite directions, thus current will flow in opposite directions in each coil. The current through each coil at the vertex region flows in the same direction. The windings of the two coils are connected through a crossover region, where the windings forming one coil become continuous with the windings forming the other coil. The crossover region may occur at the vertex area (e.g., where the adjacent coils meet), or may be anywhere else between the coils. The crossover region may go from the central turn of one coil to the central turn of the other coil.

[00038] A coil may be formed of any number of windings. For example, the coil may be between 8 and 12 windings, between 9 and 11 windings, between 9 and 10 windings, etc. In

some variations the coils are formed from copper flat wire, e.g., 0.984 inch by .240 inch wire), though any appropriate conductor may be used. As mentioned above, the coils forming a TMS electromagnet are typically wound in opposite directions.

[00039] As mentioned, the coil typically forms a ring or loop of many adjacent windings.

5 The stack of windings may form a rectangle when viewed as a cross-section through the loop. Thus, a cross-section through a coil may include two side surfaces (which may be the long edges) formed by the edges of all of the windings in the stack, separated by an outer surface and an inner surface (formed by the outer winding and inner winding, respectively). The side surfaces of the coil are typically curved, forming the bent ring shape of each coil.

10 [00040] In many of the examples described herein the pair of coils forming the shape-coil TMS magnets are symmetric with respect to each other. Thus, they are typically the same size (including number of windings) and shape. However, in some variations the shapes of the two coils may be different. For example, in some variations the two shaped coils forming the TMS magnet may be of different sizes. In one variation, one shaped coil has more windings than the
15 other shaped coil. In some variations one coil has a different shape than the other coil. For example, in some variations one coil has a different curvature of bending than the other coil.

[00041] In some variations the coils are generally circular rings formed by the windings of the conductor. The coil does not necessary have to be circular, but could be oval polygonal, or the like.

20 [00042] FIG. 1 is a cross-section though one variation of a shaped coil having an I-bottom configuration. In this variation, the vertex (the connection between the two coils) is formed so that the stacks of windings of each of the two coils are arranged parallel to each other. Thus, the cross-section appears to roughly form the endpoints of a "Y" shape, with the bottom portion of the "Y" being the parallel and adjacent windings of the coils at the vertex (the inner coil region).
25 In FIG. 1, the cross-section through the first outer coil region 110 is part of the same shaped coil (subcoil A) as the cross-section through the first inner coil region 111, and the cross-section through the second outer coil region 120 is part of the same shaped coil (subcoil B) as the cross section through the second inner coil region 121. The cross-section of the two inner coil regions 111, 121 are parallel. The maximum angle of this variation of shaped coil TMS electromagnet is
30 illustrated 130 as the angle between the upper margin of subcoil B and the normal (flat) plane. In this embodiment, this angle is 60 degrees. The maximum angle between the bent wings of the coils is also 60 degrees. The angle at the outermost edges of the coil from the vertex where the coils meet may be referred to as the angle of the shaped coil TMS electrode. In FIG. 1, this

angle is 60°, both relative to the two coils (the “wings” of the coils) and relative to a plane that is perpendicular to the axis of symmetry through the vertex. The angle of the shaped coil TMS electromagnet in some variations may be any value between 15 and 75 degrees relative to the perpendicular plane (angle 130 in FIG. 1). Equivalently, the angle between the outermost coil regions of the shaped coils may be between about 150° and 30°.

[00043] The inventors have found that the field emitted by the shaped coil TMS electromagnet shown in FIG. 1 is generally directed downward, towards the target 190, as indicated in FIG. 1. This field is shaped so that is more focused compared to a comparable “flat” (i.e., figure-8) TMS coil.

10 [00044] FIG. 2A shows another variation of a V-shaped TMS electromagnet. In FIG. 2A, the shaped coil TMS electromagnet has a flat bottom, and may be referred to as a flat bottomed TMS electromagnet (or “flat bottomed V-shaped TMS electromagnet”). In this variation, the first (or “A”) subcoil 201 is adjacent to the second (or “B”) subcoil 202 so that the vertex between the two is a flat region having a zone of mutual induction 204 where subcoils A and B meet. The direction of electrical current in coils 205 is indicated, illustrating that current flows in opposite directions in the coils (e.g., clockwise/counterclockwise), and is oriented in the same direction at the region where the coils form the vertex 204. In general, the current in the vertex region between the two coils may travel in the same direction, thereby inducing a consistent magnetic field.

20 [00045] In the example shown in FIG. 2A, the angle of the shaped coil TMS electromagnet is approximately 45 degrees relative to the horizontal, as indicated in the cross-sectional schematic shown below the partial sections through the two coils. Thus, the angle between the outer coil regions is approximately 90°. In some variations, the angle between the outer coil regions is less than 90°, for example, between about 45° and about 80° (e.g., between about 55° and about 60°). In some variations the angle is greater than 90° (e.g., between about 25 100° and 170°, between about 110° and 160°, between about 120° and 150°, etc.).

[00046] FIGS. 2B to 2E illustrate various V-shaped TMS electromagnets having different configurations. Each of these exemplary TMS electromagnets has a coil angle of 60 degrees, however the arrangement of the vertex is different. For example, FIG. 2B shows a cross-section though another variation of a flat-bottomed V-shaped TMS electromagnet. The variation may be referred to as a generally “U” shaped profile, because of the substantially flat bottom of the vertex region. The angles between the cross-sections of the outer coil regions 210, 215 of the two subcoils in this example is approximately 60 degrees. The angle between the cross-sections

of the inner coil regions 211, 216 is 180° (or 0° relative to the horizontal plane). Thus, the inner coil regions of the two coils are arranged so that they are side-by-side, forming the flat bottom.

[00047] FIG. 2C shows a cross-section through the TMS electromagnet in which the outer coil regions 220, 225 of each coil are oriented in the same direction as the cross-section through the inner coil regions 221, 226 for each coil. The two coils have an angle between them of 60 degrees relative both to each other and to the horizontal. Thus, both of the lower regions forming the vertex are angled 60 degrees from the horizontal. This shape may be similar to the other commercially available “butterfly” double coils, although oriented opposite the variation shown here, and may have the same drawbacks inherent in those magnets. In particular, such a butterfly coil does not include a central planar region where the coils meet (the vertex). This may result in a weaker field, since the each subcoil is wound in a single plane, and the two flat plane components are offset by an angle.

[00048] FIG. 2D illustrates another variation of an I-bottomed TMS electromagnet. In this variation, the outer coil regions 230,235 are both angled 60 degrees from the horizontal (and relative to each other), but the cross-section through the inner coil regions at the vertex show that two inner coil regions are parallel (angled 90° with the horizontal and 0° relative to each other).

[00049] FIG. 2E shows an example of a shaped coil TMS electromagnet having an interleaved bottom region. In this example, the windings forming the bottom region of the vertex are not stacked in a single column, but are some of them run adjacent to each other for at least part of the region forming the vertex. The outer coil regions of each coil remain wound in a single (stacked) column). Thus the vertex (bottom or base region of the magnet) maximizes the contact between the adjacent windings of each coil while minimizing the distance from the coils to the target. The coil windings at the inner coil region (in the vertex region) for each coil may be arranged to form a flat surface that can abut a similar flat surface on the adjacent coil. In some variations the coil windings between the two regions 241, 246 may overlap with each other. In FIG. 2E, the coil windings of the joined coils 241, 246 forming the vertex are organized so that they have an approximately circular cross-section. The cross-sections 241, 246 of the vertex inner coil regions are shown having nine rectangular windings; as mentioned above, other shapes of winding material (circular cross-sections, etc.), as well as coils having more or fewer windings may be used.

[00050] FIG. 2F shows another variation of a shaped coil TMS electromagnet with an interleaved bottom. These regions are referred to as “interleaved” because the windings forming the vertex region for the coils are not strictly wound in a stacked column, but may overlap or be

wound next to each other, as shown. In FIG., 2F, the vertex region of the TMS electromagnet has a triangularly shaped cross-section for the coils. In FIG. 2F the vertex is again formed by maximizing the contact between the adjacent coils while minimizing the distance from the coils to the target. In the variation shown in FIG. 2F, the coil windings have been organized so that they form an approximately triangular cross-section, having a flat surface that faces the target direction. The cross-sections 251, 256 through the inner coil regions are shown with ten rectangular windings, and the outer coil regions 250, 255 are each at a 60 degree angle with the horizontal in this example. Any of the angles described above may be used for the coils. For example, the wings of the TMS electromagnet may be separated by between about 60° and about 150°.

[00051] FIGS. 3A to 3C illustrate one variation of an I-bottomed (Y-shaped) TMS electromagnet, similar to the one shown in cross-section in FIG. 1 and FIG. 2D. In FIG. 3A the two coils forming the TMS electromagnet include a first subcoil 302 (subcoil A) and a second subcoil 301 (subcoil B). The two subcoils meet in a vertex region 305. This central section (vertex) is in a substantially perpendicular orientation with respect to the target, as illustrated in FIG. 1 by the arrow. The emitted field will be directed towards the target in this direction. The portions of the subcoils 301, 302 forming the vertex 305 are substantially parallel in the vertex region, as better seen in FIG. 3B.

[00052] The crossover region 303 shown in FIG. 3A-3C extends between the central loops of the two coils, and is not located in the vertex region, although it could be. These figures also illustrate the connections to the power source for the coils 310, 311. For example, a TMS electromagnet may be electrically connected to a power source to provide an electrical current that is pulsed with a magnitude of about 5000A.

[00053] Any of the TMS electromagnets described herein may also include a support structure. FIG. 4 shows one variation of a shaped coil TMS electromagnet secured to a support structure. The TMS electromagnet in this example is a Y-shaped shaped coil TMS electromagnet similar to those described above. This example includes two concentric double (sub)coils of approximately the same diameter windings as a standard 70mm double coil. The inner coil region of each subcoil (of the double coil structure) forming the vertex are placed side-by-side vertically, and the outer coil regions of the loops are swept to 60 degrees from the horizontal plane (with an angle between the outer coil regions of 60°). This variation may be constructed using a single length of flat wire, with no solder at the crossover.

[00054] The structural support matrix may completely or partially surround the coils. The structural support matrix may provide support and protect against mechanical shock.

Mechanical shock forces may be created in making and/or operation of the TMS electromagnet, particularly in the lateral wings, so a structural support matrix (which may be rigid) may be used. This support structure may be formed of a low electrical conductivity and high thermal conductivity material. In some variations, the support structure may be a hollow strut system that facilitates cooling by air flow/convection, or a solid matrix for heat conduction. The support structure may be filled with a fluid to assist in heat transfer.

[00055] In general, the shaped coil TMS electromagnets described herein include two coils that are arranged so that the outer portions of each coil (subcoil) are at an angle with respect to the horizontal, and the vertex of the coils, where they are immediately adjacent to each other, may be arranged at a different angle, or to maximize the contact between the loops of the two coils while also maximizing the portion of the coils nearest the target. For example, in one variation an I-bottomed V-shaped TMS electromagnet is configured so that the outer portions of each coil are at an angle of 60 degrees with respect to the horizontal (also forming an angle of 60 degrees between them), while the vertex region of the TMS electromagnet is formed by placing the coils regions parallel to each other, so that the vertex region of each coil forms an angle of 90 degrees with the horizontal. In all of these cases the "horizontal" direction will correspond to the plane of the target. The horizontal direction is also perpendicular to the axes of symmetry for the coils.

[00056] In some variations the TMS electromagnets described herein may be defined by the angles formed by the outer portion of the coils with horizontal and the angles formed by the inner or vertex portions of the coil with the horizontal. The angle formed by the outer portion of the coils may be around about 60 degrees (e.g., between about 50 and about 70 degrees, between about 45 and about 75 degrees, between about 55 and about 65 degrees, etc.) The angle formed by the inner or vertex portion may be any angle between 0 and 90 degrees. In particular, the angle may be 90 degrees. In still other variations, the loops of the coils forming the vertex are arranged to maximize the contact between loops of adjacent coils. For example, the coils may be arranged so that the loops of each coil in the vertex region form a semicircle that combine to form a circle. In one variation, the coils may be arranged so that the loops of each coil in the vertex region form a right triangle which matches up with the adjacent coil to form a triangle. FIG. 2F illustrates one variation of this coil arrangement.

[00057] The various embodiments described above are provided by way of illustration only and should not be construed to limit the invention. Based on the above discussion and

illustrations, those skilled in the art will readily recognize that various modifications and changes may be made to the present invention without strictly following the exemplary embodiments and applications illustrated and described herein. Such modifications and changes do not depart from the true spirit and scope of the present invention, which is set forth in the following claims.

CLAIMS

What is claimed is:

1. A Y-shaped Transcranial Magnetic Stimulation (TMS) electromagnet configured to
5 emit a focused magnetic field, the TMS electromagnet comprising:
a first bent magnetic coil loop comprising a plurality of windings and a second
bent magnetic coil loop comprising a plurality of windings;
wherein the first magnetic coil loop comprises a first inner coil region and the
second magnetic coil loop comprises a second inner coil region, and wherein
10 the first and second inner coil regions are arranged to form a vertex
configured so that the plurality of windings within the first inner coil region
for a column this is adjacent and parallel to the plurality of windings within
the second inner coil that are arranged in a column; and
wherein the first magnetic coil loop comprises a first outer coil region and the
15 second magnetic coil loop comprises a second outer coil region, and the angle
between the first outer coil region and the second outer coil region is between
about 30 degrees and about 120 degrees.
2. The TMS electromagnet of claim 1, wherein the first outer coil region is opposite the
first inner coil region on the first magnetic coil loop and wherein the second outer coil
20 region is opposite the second inner coil region on the second magnetic coil loop.
3. The TMS electromagnet of claim 1, wherein the first bent magnetic coil loop comprise
greater than 5 windings.
4. The TMS electromagnet of claim 1, wherein the angle between the first outer coil
region and the second outer coil region is approximately 60 degrees.
- 25 5. The TMS electromagnet of claim 1, further comprising a structural support matrix
surrounding the first and second bent magnetic coil loops.
6. The TMS electromagnet of claim 1, wherein the first and second bent magnetic coil
loops are electrically connected so that the current flows from the first coil loop into
the second coil loop.

7. The TMS electromagnet of claim 1, wherein the vertex is configured so that current will flow in the same direction in the first and second inner coil regions of the vertex.
8. The TMS electromagnet of claim 1, wherein the first and second bent magnetic coil loops are arranged symmetrically about the vertex.
- 5 9. The TMS electromagnet of claim 1, wherein the first and second bent magnetic coil loops have approximately the same shape and size.
10. A shaped coil Transcranial Magnetic Stimulation (TMS) electromagnet comprising:
 - a first bent magnetic coil loop comprising a column formed of a plurality of conductive windings;
 - 10 a second bent magnetic coil loop comprising a column formed of a plurality of conductive windings; and
 - a vertex region connecting the first and second bent magnetic coil loops; wherein the vertex region is formed by aligning the columns of conductive windings within the first bent magnetic coil loop in parallel with the column of
 - 15 conductive windings within the second bent magnetic coil loop;
 - wherein the angle between a first outer coil region of the first magnetic coil loop and a second outer coil region of the second magnetic coil loop is less than 120 degrees.
11. The shaped TMS electromagnet of claim 10, wherein the vertex region comprise an I-bottomed vertex.
- 20 12. The shaped TMS electromagnet of claim 10, wherein the vertex region comprises an interleaved vertex.
13. The shaped TMS electromagnet of claim 10, wherein the first outer coil region is opposite the vertex region on the first magnetic coil loop and wherein the second outer
- 25 coil region is opposite the vertex region on the second magnetic coil loop.
14. The shaped TMS electromagnet of claim 10, wherein the first magnetic coil loop comprise greater than 5 windings.
15. The shaped TMS electromagnet of claim 10, wherein the angle between a first outer
- 30 coil region of the first magnetic coil loop and a second outer coil region of the second magnetic coil loop is approximately 60 degrees.

16. The shaped TMS electromagnet of claim 10, further comprising a structural support matrix surrounding the first and second magnetic coil loops.
17. The shaped TMS electromagnet of claim 10, wherein the first and second bent magnetic coil loops are electrically connected so that the current flows from the first bent magnetic coil loop into the second bent magnetic coil loop.
18. The shaped TMS electromagnet of claim 10, wherein the vertex is configured so that current will flow in the same direction in the portion of the windings forming the first and second bent magnetic coil loops that are part of the vertex.
19. The shaped TMS electromagnet of claim 10, wherein the first and second bent magnetic coil loops are arranged symmetrically about the vertex.
20. The shaped TMS electromagnet of claim 10, wherein the first and second bent magnetic coil loops have approximately the same shape and size.
21. A shaped coil Transcranial Magnetic Stimulation (TMS) electromagnet comprising:
a first bent magnetic coil loop comprising a plurality of conductive windings;
a second bent magnetic coil loop comprising a plurality of conductive windings;
and
a generally V-shaped bottom vertex region between the first and second bent magnetic coil loops;
wherein the angle between an outer coil region of the first bent magnetic coil loop and the outer coil region of the second bent magnetic coil loop is between about 55 and about 65 degrees; and
wherein the V-shaped bottom vertex region is formed by arranging immediately adjacent portions of the each coil at an angle of between about 70 and about 110 degrees relative to each other.
22. A shaped Transcranial Magnetic Stimulation (TMS) electromagnet comprising:
a first bent magnetic coil loop formed of a column comprising a plurality of windings;
a second bent magnetic coil loop formed of a column comprising a plurality of windings;
a flat-bottomed vertex region between the first and second bent magnetic coil loops;

wherein the angle between an outer coil region of the first bent magnetic coil loop and the outer coil region of the second bent magnetic coil loop is between about 55 and about 65 degrees; and

5 wherein the flat-bottom vertex region is formed by arranging an inner coil region of the first bent magnetic coil loop immediately adjacent to an inner coil region of the second bent magnetic coil loop so that the column of windings forming the first and second inner coil regions are at an angle of approximately 180 degrees with respect to each other.

10

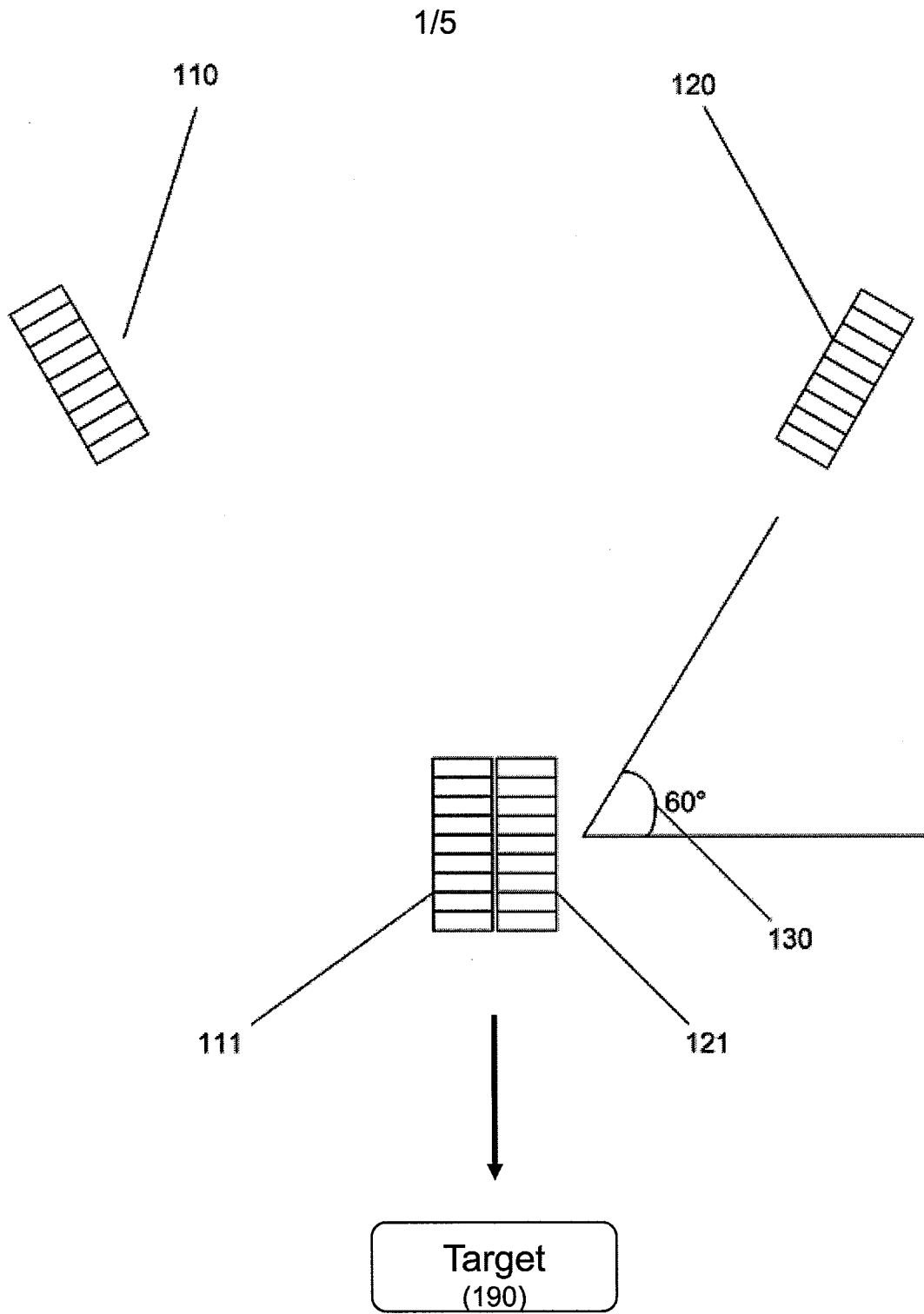
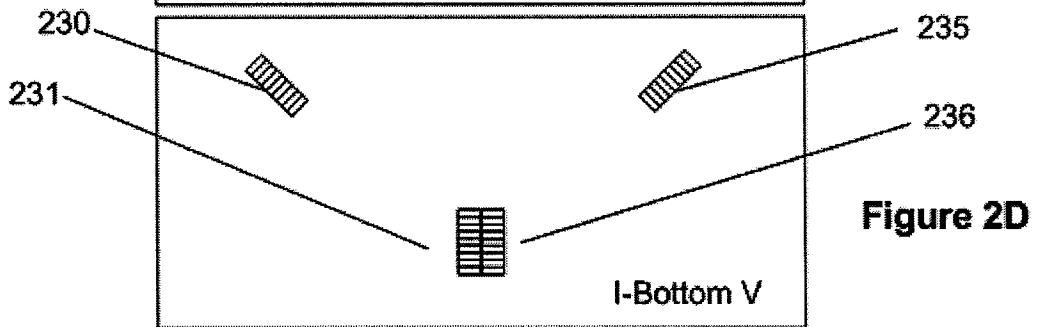
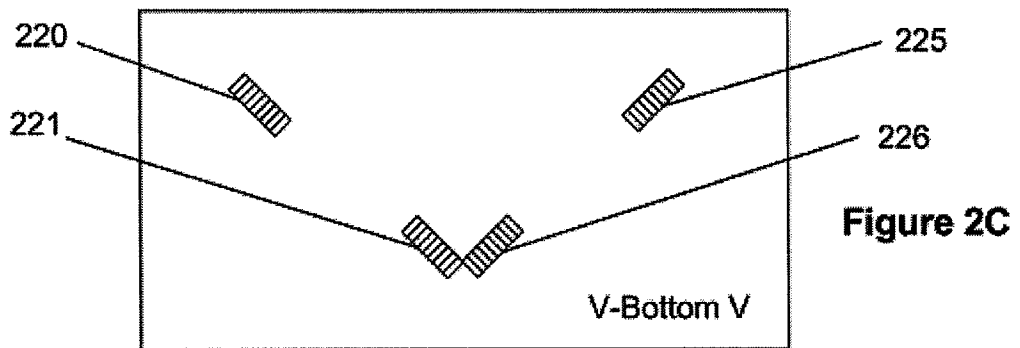
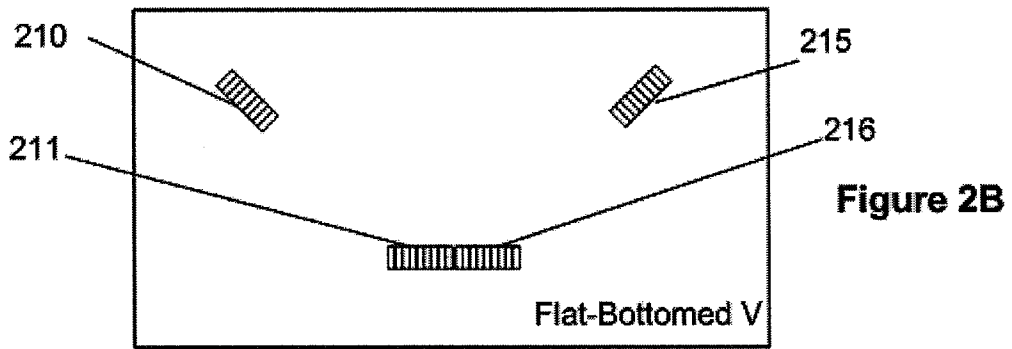
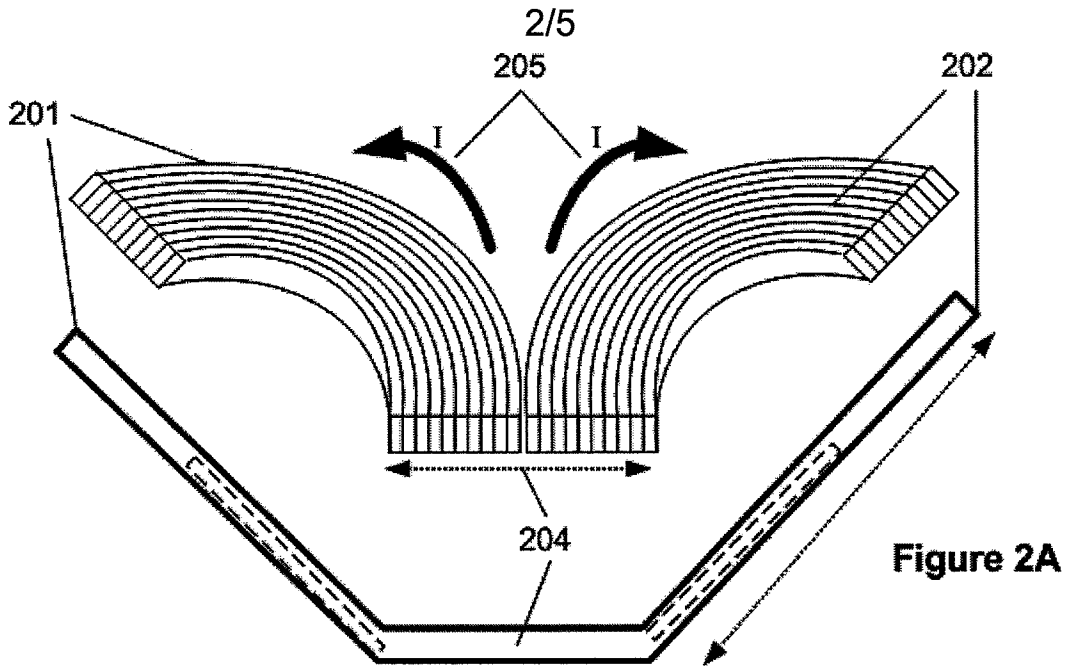

FIG. 1



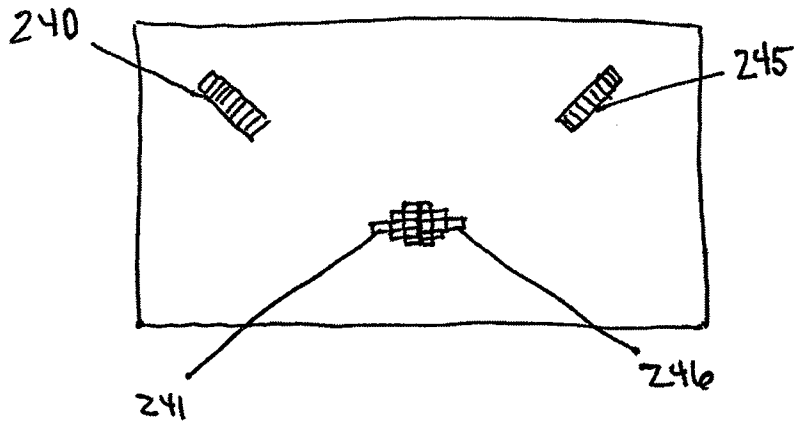

Fig. 2E

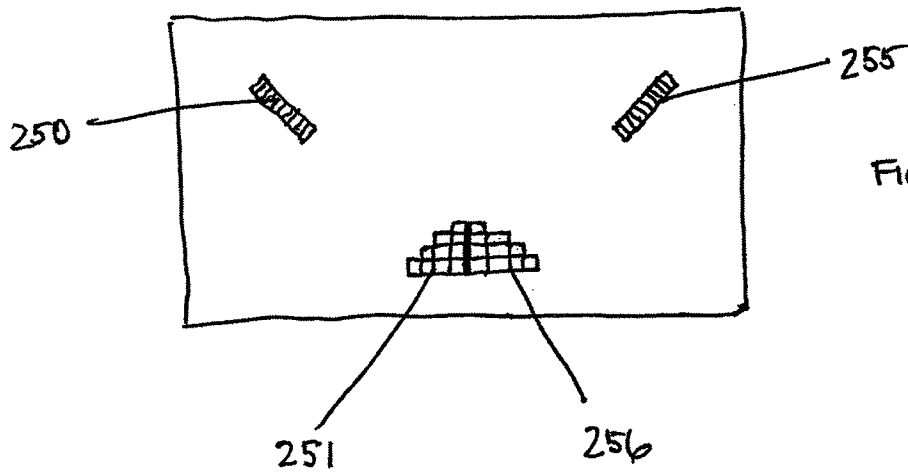
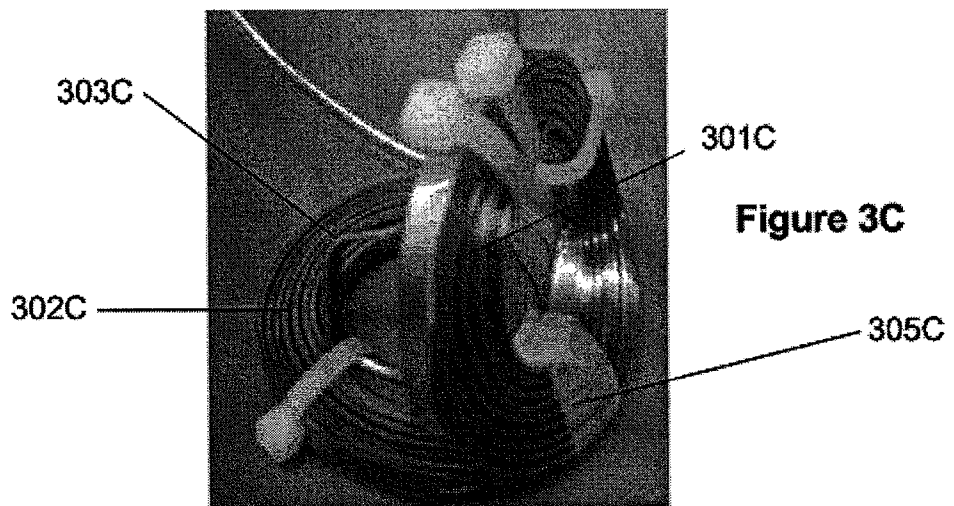
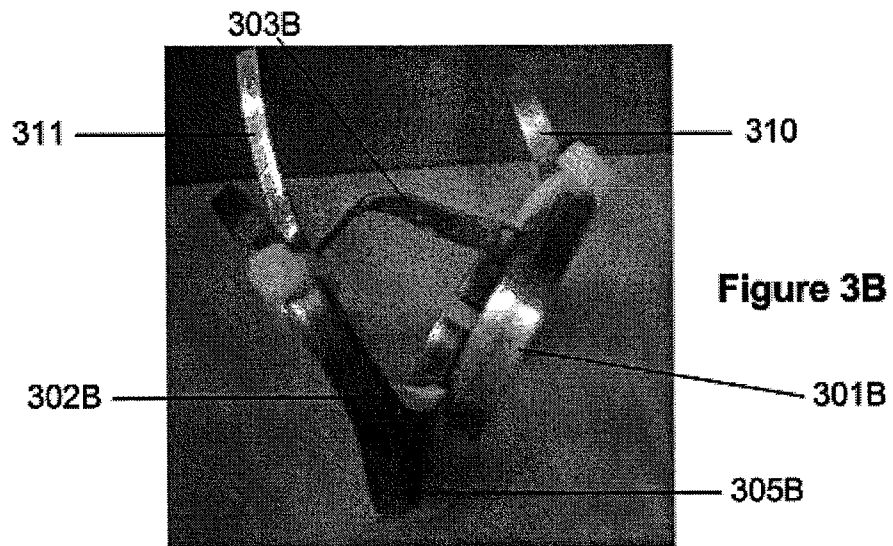
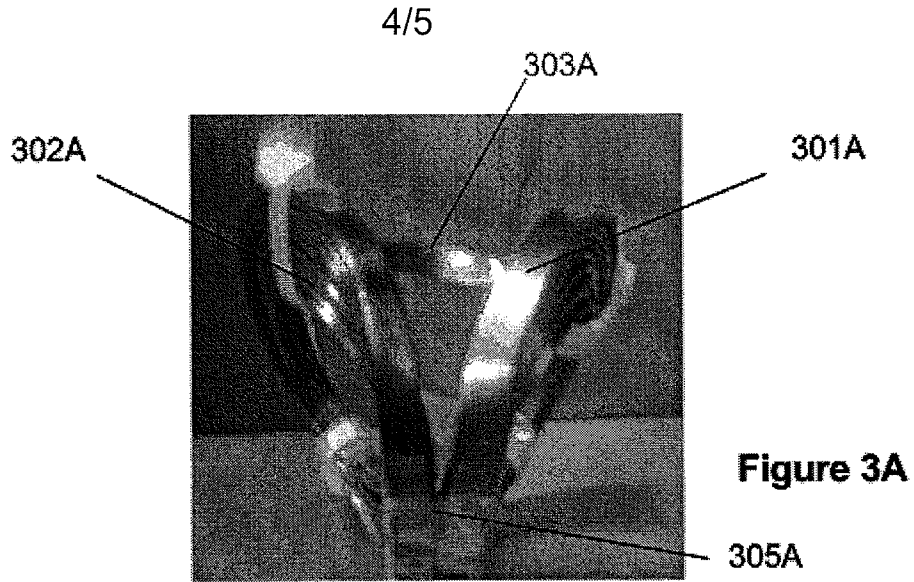

Fig. 2F



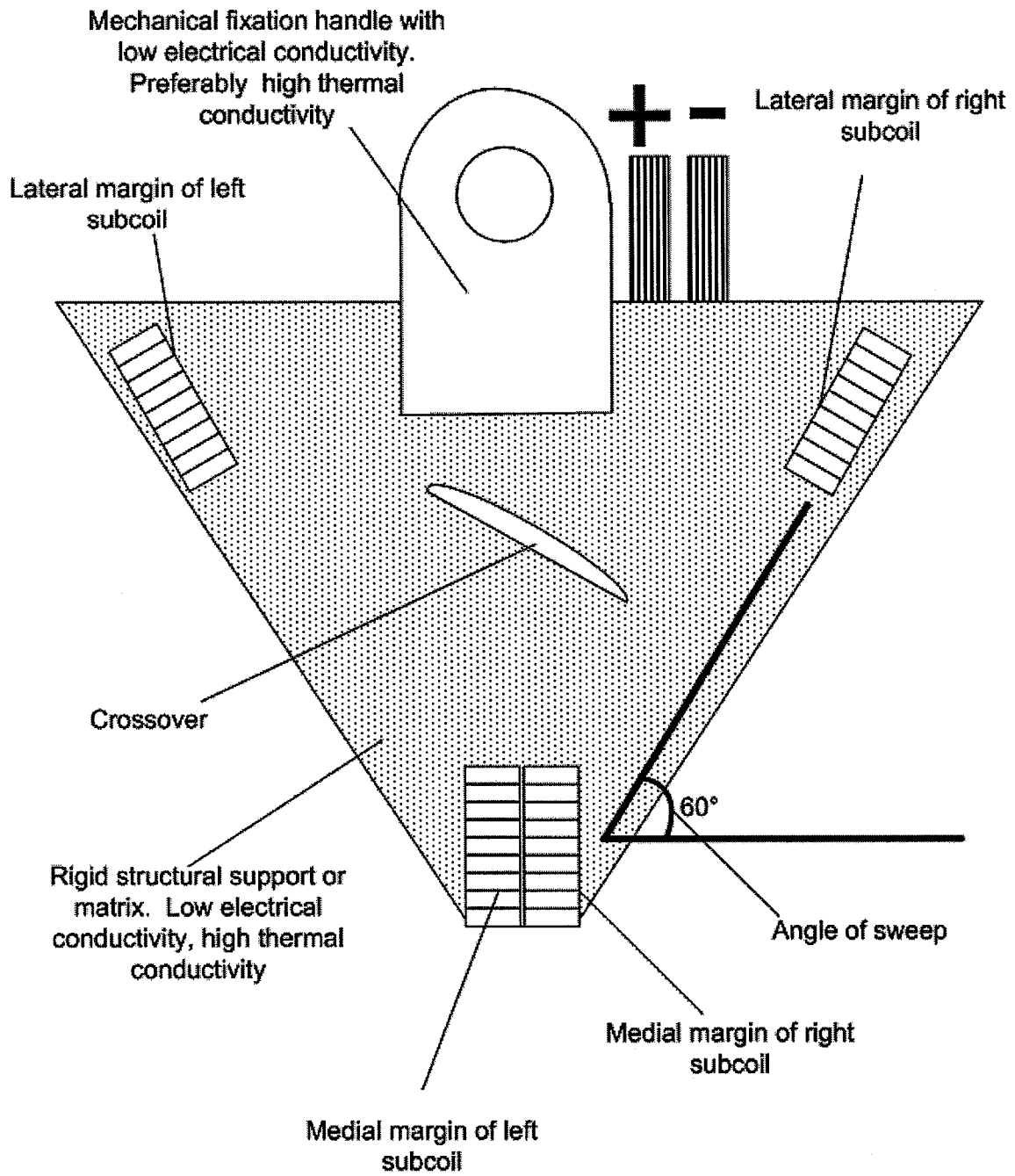

FIG. 4