

(19)
(12)

(KR)
(A)

(51) 。 Int. Cl. ⁷
B21D 22/30

(11)
(43)

2002 - 0005076
2002 01 17

(21) 10 - 2000 - 0038000
(22) 2000 07 04

(71) ()

49 - 5

(72) 6 - 1403

(74)
:

(54) 가 ,

가

,

,

가

가

가

(R)

(C1)

(4)

(6)

;

(4)

(7 - a)

;

(6)

(5)

(5 - a)

(C2)

(8)

(8) 가

;

(4)

가

.

1 ,
 2 (1 "가") ,
 3 ,
 4 ,
 5 ,
 6 5 3 ,
 7 ,
 8, 9 7 4 ,
 10 ,
 11, 12, 13 10 4 .

< >

(4) : (5) :

(6) : (7) :

(8) :

H1 :

b :

d :

H2 :

가

가 가 .

가 , 가 가 , , ,

5 (6-a) , 3 6 2 r

7 .

5 3 (3) () b 가 , 6 6 H1 가

(3) 가 , 가

7 , 8 7 3

4 d . , 9

가 , H2

7 .

, 가 가

1 , (H) 가 (D) (D-1), (D-2)

1 3 (3)가 가

(H-1),(H-2) , 가 2

(R) ;

(4) (6) (C1) ;

(6) (5) (C2) ;

가 , (4) (7 - a) ; (5 - a) (8)

(4) (8) 가

10 . (R) 3

H가 .

11 (4) , (4) (6) (C1)

, (6) (C2) (6)

12 (4)가 (7 - a)

(4)가 (5 - a) 가 (8)

2 H - 2가 13 가

7 .

, , 가 가 ,

가 , 가

(57)

1.

(R) ;

(4) (6) (C1) ;

(6) (5) (C2) ;

가 , (4) (7-a) ; (5-a) (8)
(4) (8) 가

1

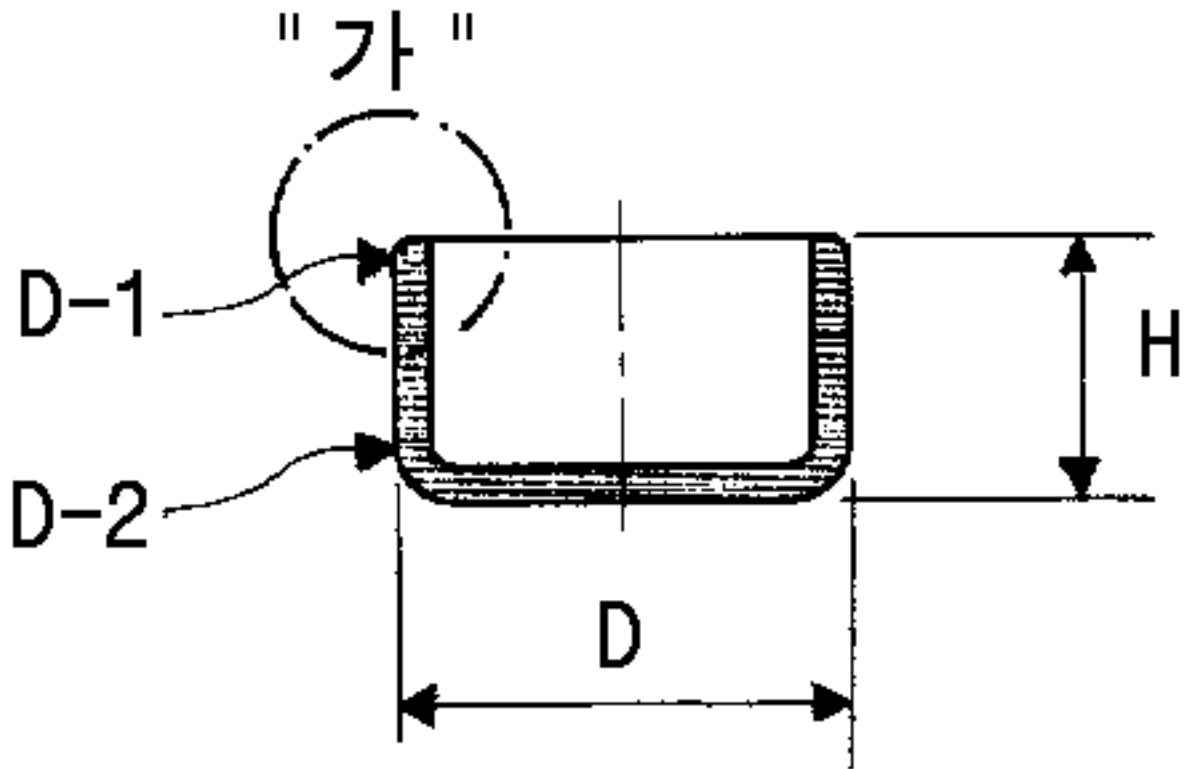

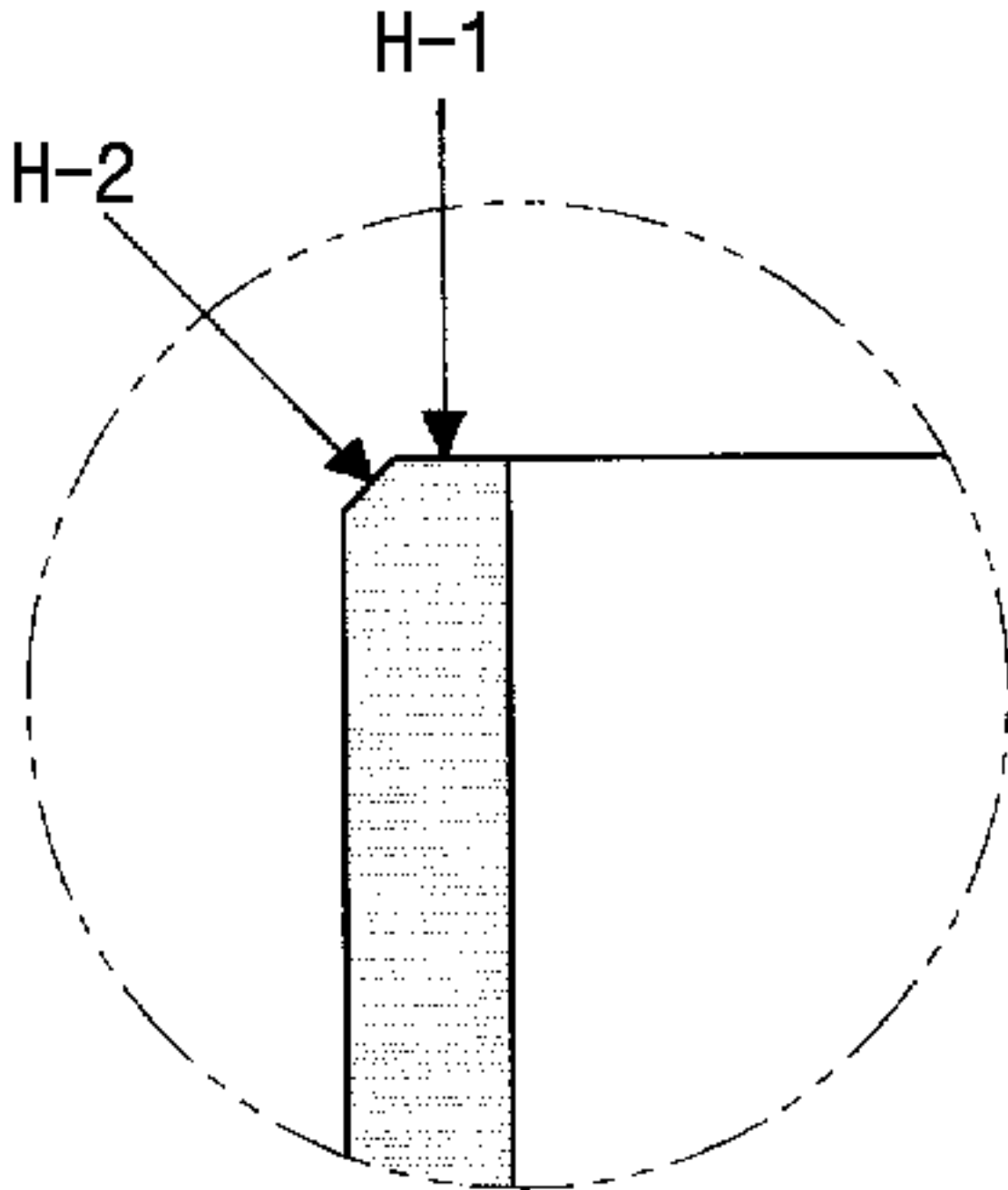

3

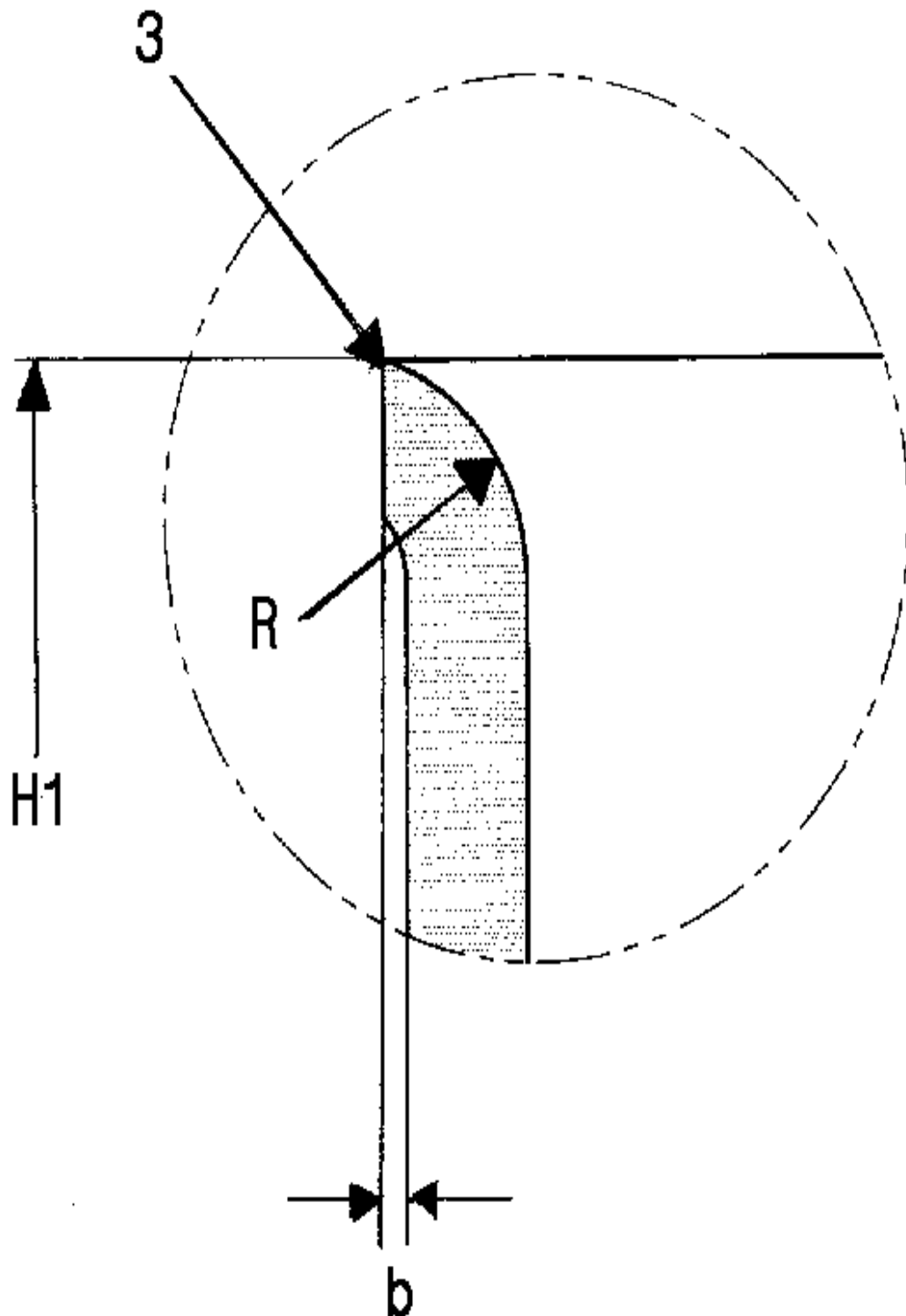

4

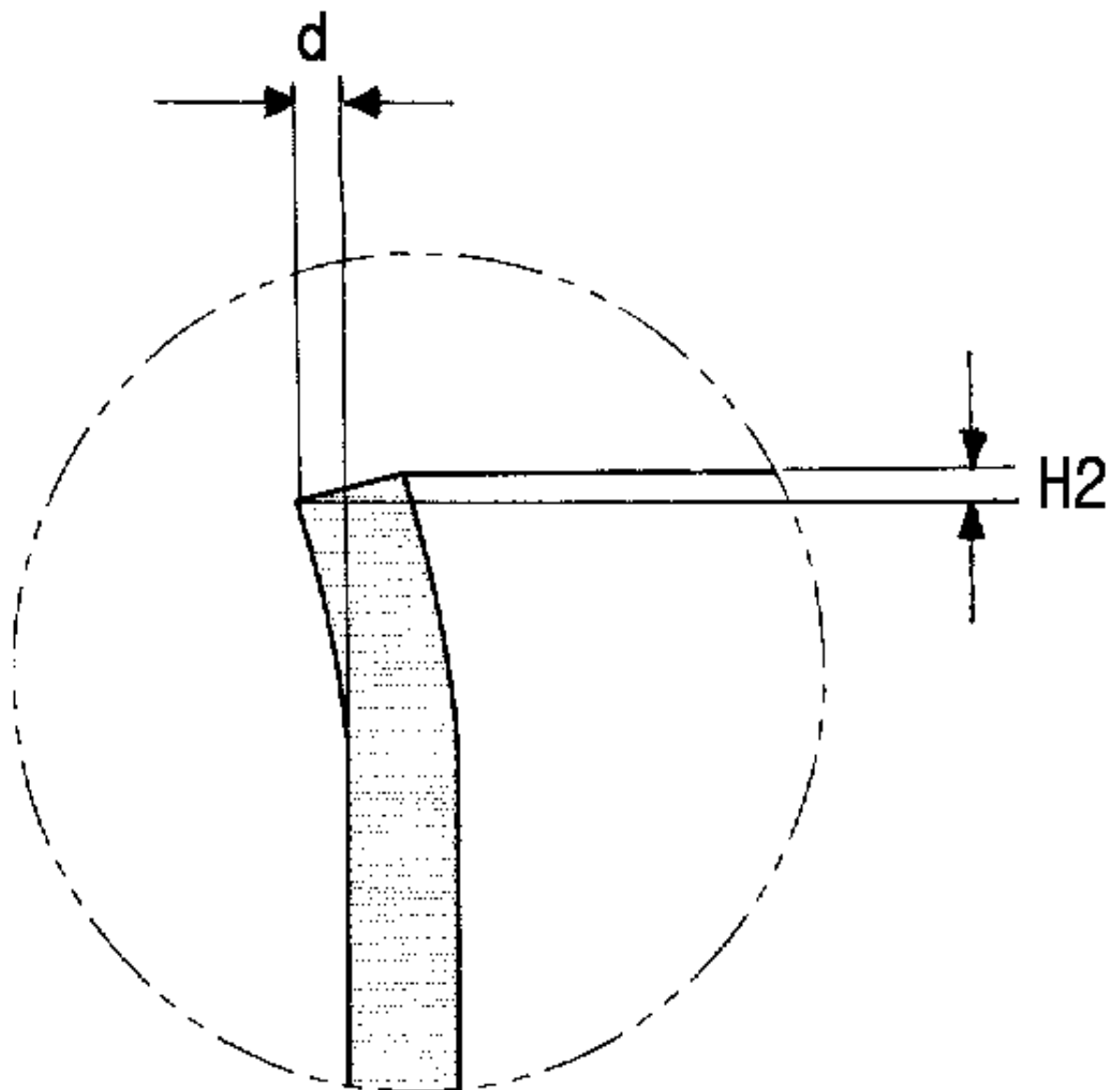

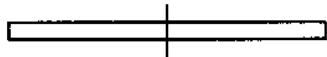

<제 1 공정 >

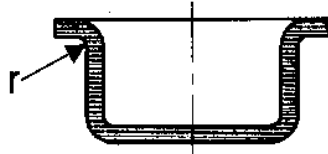

<제 2 공정 >

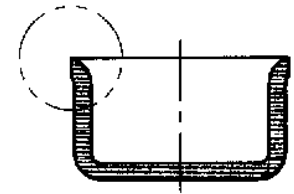

<제 3 공정 >

5

6

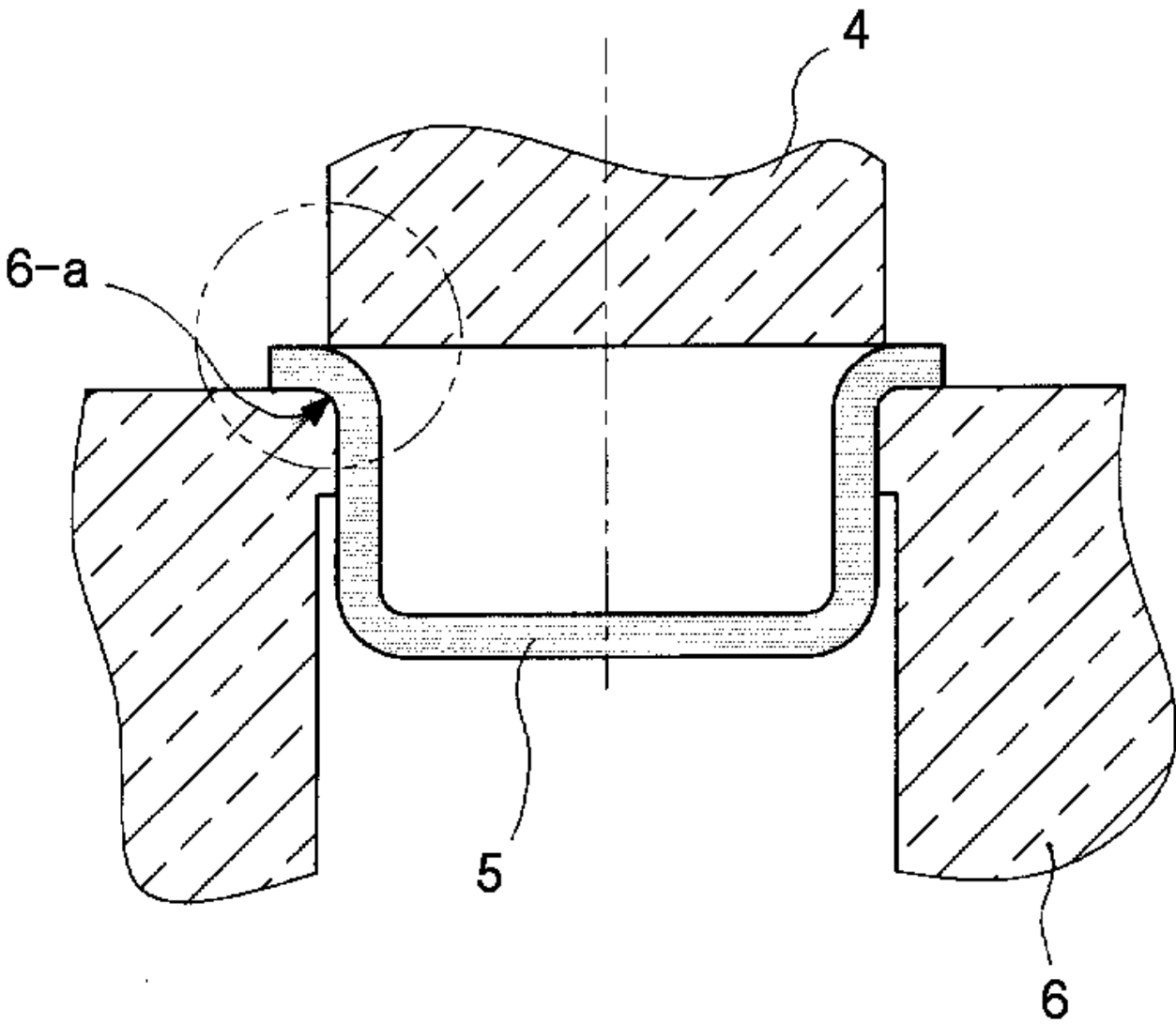

7



<제 1 공정 >

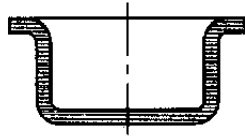

<제 2 공정 >

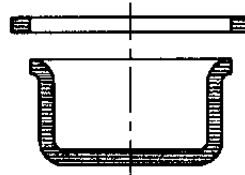

<제 3 공정 >

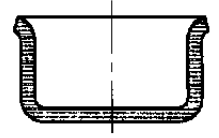

<제 4 공정 >

8

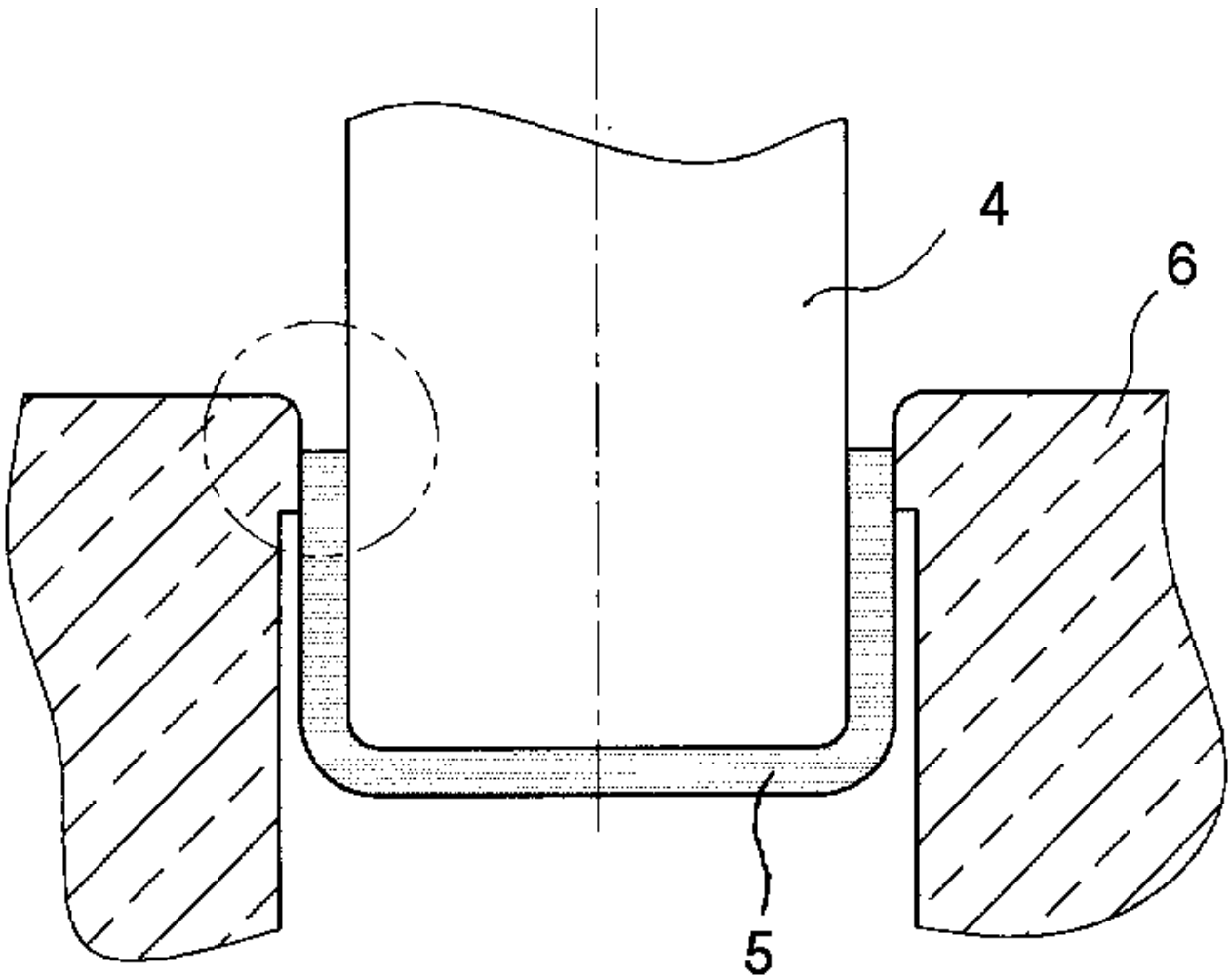

9

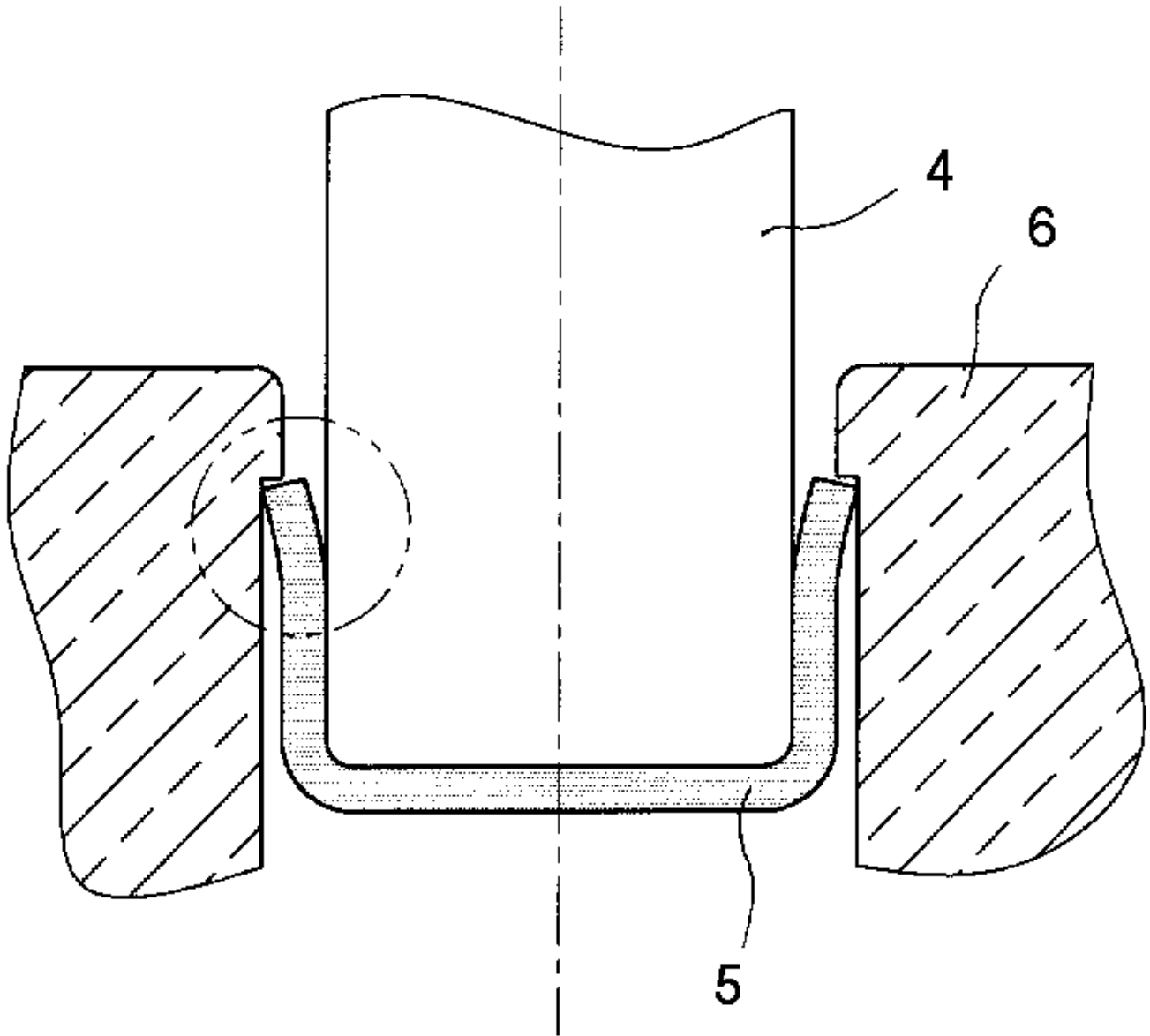

10

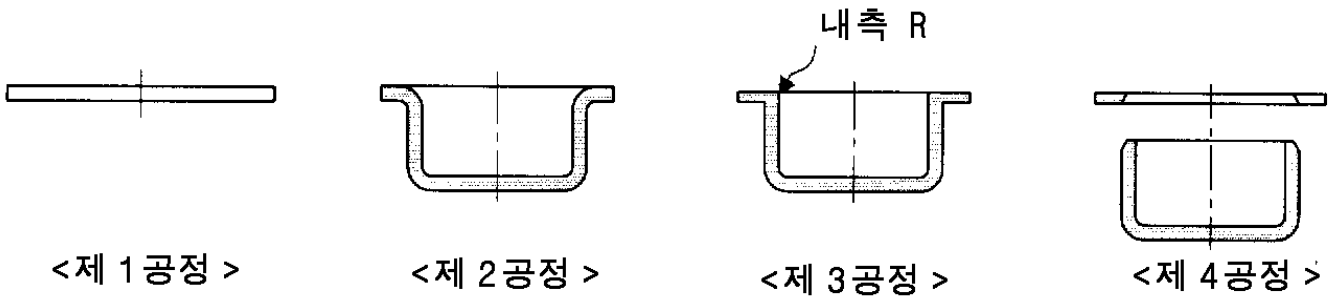

11

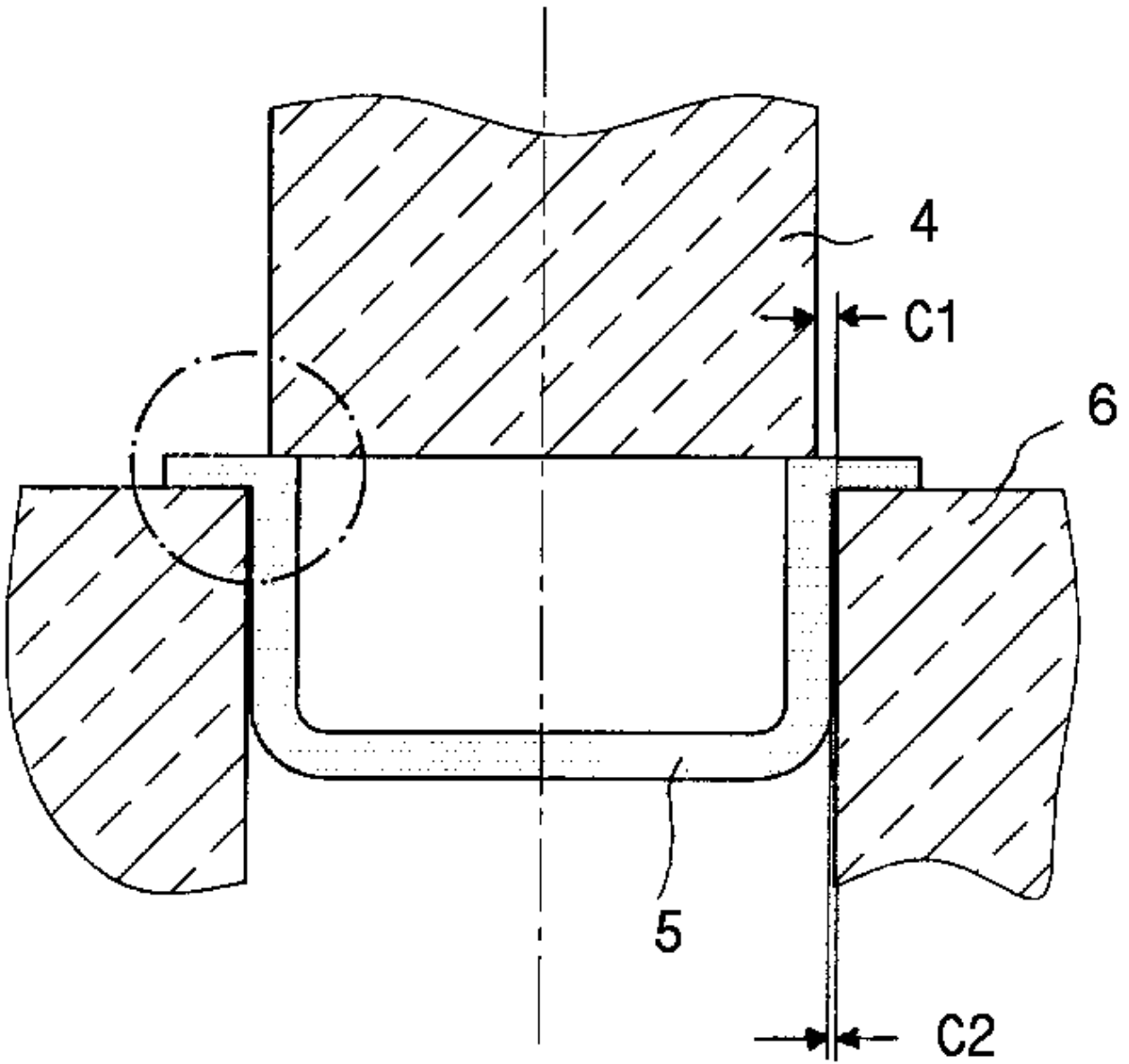

12

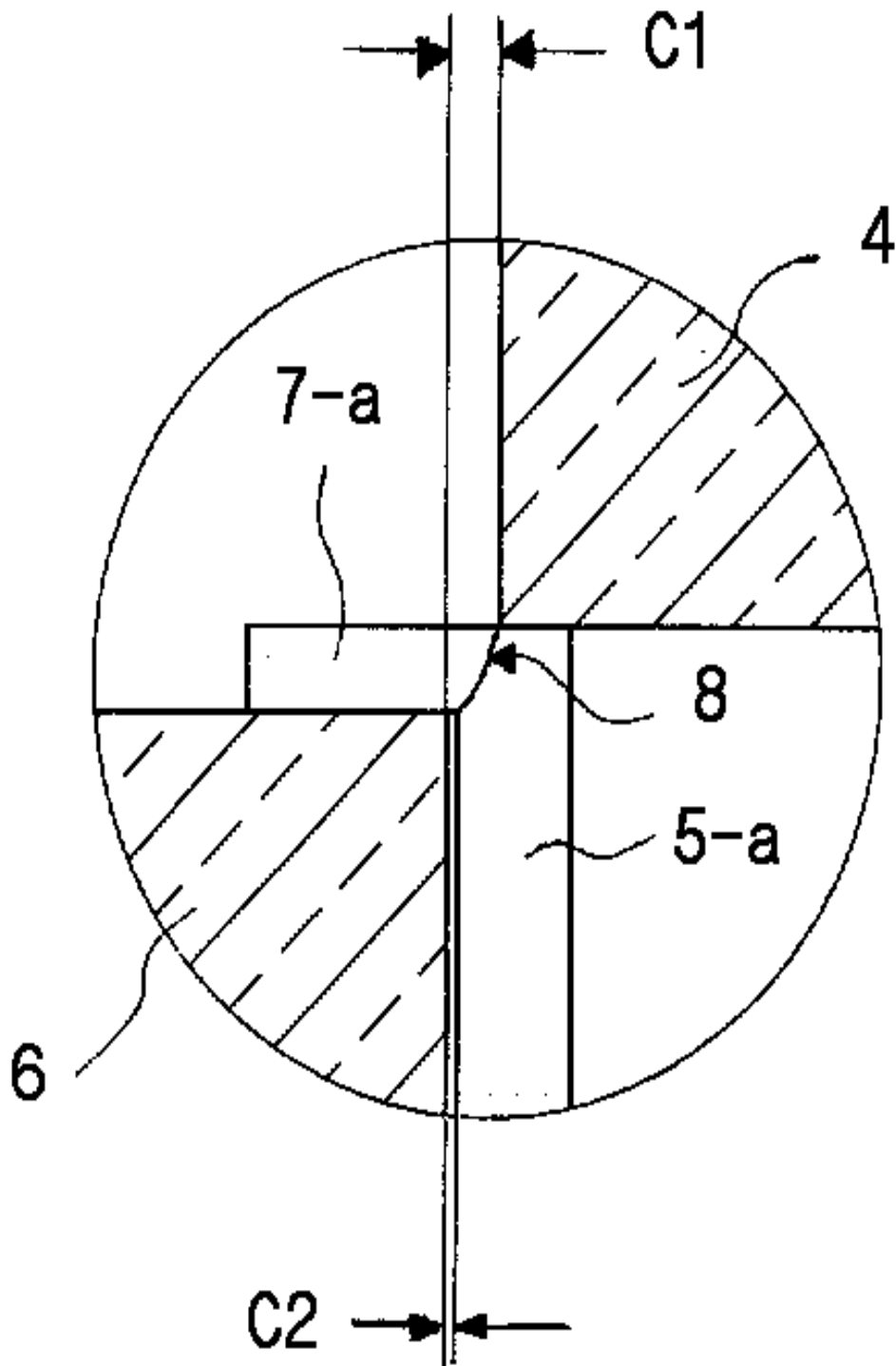

13

