



INTERNATIONAL APPLICATION PUBLISHED UNDER THE PATENT COOPERATION TREATY (PCT)

<p>(51) International Patent Classification ⁶ : A61F 2/06</p>	<p>A1</p>	<p>(11) International Publication Number: WO 97/25938</p> <p>(43) International Publication Date: 24 July 1997 (24.07.97)</p>
<p>(21) International Application Number: PCT/US97/01720</p> <p>(22) International Filing Date: 22 January 1997 (22.01.97)</p> <p>(30) Priority Data: 08/588,052 22 January 1996 (22.01.96) US</p> <p>(71) Applicant: MEADOX MEDICALS, INC. [US/US]; 112 Bauer Drive, Oakland, NJ 07436 (US).</p> <p>(72) Inventors: LENTZ, David, J.; 23 Timber Lane, Randolph, NJ 07869 (US). HENDERSON, Jamie; 55 Truman Boulevard, Oakland, NJ 07436 (US). DORMIER, Edward, J.; 17 Lea Place, Rockaway, NJ 07886 (US). ZDRAHALA, Richard, J.; 39 Cobblestone Terrace, Montville, NJ 07045 (US).</p> <p>(74) Agents: SCOLA, Daniel, A., Jr. et al.; Hoffmann & Baron, 350 Jericho Turnpike, Jericho, NY 11753 (US).</p>		<p>(81) Designated States: AL, AM, AT, AU, AZ, BA, BB, BG, BR, BY, CA, CH, CN, CU, CZ, DE, DK, EE, ES, FI, GB, GE, HU, IL, IS, JP, KE, KG, KP, KR, KZ, LC, LK, LR, LS, LT, LU, LV, MD, MG, MK, MN, MW, MX, NO, NZ, PL, PT, RO, RU, SD, SE, SG, SI, SK, TJ, TM, TR, TT, UA, UG, UZ, VN, ARIPO patent (KE, LS, MW, SD, SZ, UG), Eurasian patent (AM, AZ, BY, KG, KZ, MD, RU, TJ, TM), European patent (AT, BE, CH, DE, DK, ES, FI, FR, GB, GR, IE, IT, LU, MC, NL, PT, SE), OAPI patent (BF, BJ, CF, CG, CI, CM, GA, GN, ML, MR, NE, SN, TD, TG).</p> <p>Published <i>With international search report. Before the expiration of the time limit for amending the claims and to be republished in the event of the receipt of amendments.</i></p>
<p>(54) Title: IMPROVED PTFE VASCULAR GRAFT AND METHOD OF MANUFACTURE</p>		
<p>(57) Abstract</p> <p>An implantable microporous ePTFE tubular vascular graft exhibits long term patency, superior radial tensile strength and suture hole elongation resistance. The graft includes a first ePTFE tube and a second ePTFE tube circumferentially disposed over the first tube. The first ePTFE tube exhibits a porosity sufficient to promote cell endothelialization tissue ingrowth and healing. The second ePTFE tube exhibits enhanced radial strength in excess of the radial tensile strength of the first tube.</p>		

FOR THE PURPOSES OF INFORMATION ONLY

Codes used to identify States party to the PCT on the front pages of pamphlets publishing international applications under the PCT.

AM	Armenia	GB	United Kingdom	MW	Malawi
AT	Austria	GE	Georgia	MX	Mexico
AU	Australia	GN	Guinea	NE	Niger
BB	Barbados	GR	Greece	NL	Netherlands
BE	Belgium	HU	Hungary	NO	Norway
BF	Burkina Faso	IE	Ireland	NZ	New Zealand
BG	Bulgaria	IT	Italy	PL	Poland
BJ	Benin	JP	Japan	PT	Portugal
BR	Brazil	KE	Kenya	RO	Romania
BY	Belarus	KG	Kyrgystan	RU	Russian Federation
CA	Canada	KP	Democratic People's Republic of Korea	SD	Sudan
CF	Central African Republic	KR	Republic of Korea	SE	Sweden
CG	Congo	KZ	Kazakhstan	SG	Singapore
CH	Switzerland	LI	Liechtenstein	SI	Slovenia
CI	Côte d'Ivoire	LK	Sri Lanka	SK	Slovakia
CM	Cameroon	LR	Liberia	SN	Senegal
CN	China	LT	Lithuania	SZ	Swaziland
CS	Czechoslovakia	LU	Luxembourg	TD	Chad
CZ	Czech Republic	LV	Latvia	TG	Togo
DE	Germany	MC	Monaco	TJ	Tajikistan
DK	Denmark	MD	Republic of Moldova	TT	Trinidad and Tobago
EE	Estonia	MG	Madagascar	UA	Ukraine
ES	Spain	ML	Mali	UG	Uganda
FI	Finland	MN	Mongolia	US	United States of America
FR	France	MR	Mauritania	UZ	Uzbekistan
GA	Gabon			VN	Viet Nam

IMPROVED PTFE VASCULAR GRAFT AND METHOD OF MANUFACTURE**FIELD OF INVENTION:**

The present invention relates generally to a tubular implantable prosthesis such as vascular grafts and endoprostheses formed of porous polytetrafluorethylene. More particularly, the present invention relates to a multi-layered tubular vascular graft or endoprosthesis formed from expanded polytetrafluorethylene.

5

BACKGROUND OF THE INVENTION:

It is well known to use extruded tubes of polytetrafluor-ethylene (PTFE) as implantable intraluminal prostheses, particularly vascular grafts. PTFE is particularly suitable as an implantable prosthesis as it exhibits superior biocompatibility. PTFE tubes may be used as vascular grafts in the replacement or repair of a blood vessel as PTFE exhibits low thrombogenicity. In vascular applications, the grafts are manufactured from expanded polytetrafluorethylene (ePTFE) tubes. These tubes have a microporous structure which allows natural tissue ingrowth and cell endothelization once implanted in the vascular system. This contributes to long term healing and patency of the graft.

10

15

Grafts formed of ePTFE have a fibrous state which is defined by interspaced nodes interconnected by elongated fibrils. The spaces between the node surfaces that is spanned by the fibrils is defined as the internodal distance (IND). A graft having a large IND enhances tissue ingrowth and cell endothelization as the graft is inherently more porous.

20

The art is replete with examples of microporous ePTFE tubes useful as vascular grafts. The porosity of an ePTFE vascular graft can be controlled by controlling the IND of the microporous structure of the tube. An increase in the IND within a given structure results in enhanced tissue ingrowth as well as cell endothelization along the inner surface thereof. However, such increase in the porosity of the tubular structure also results in reducing the overall radial tensile strength of the tube as well as reducing the ability for the graft to retain a suture placed therein during implantation. Also, such microporous tubular structures tend to exhibit low axial tear strength, so that a small tear or nick will tend to propagate along the length of the tube.

The art has seen attempts to increase the radial tensile and axial tear strength of microporous ePTFE tubes. These attempts seek to modify the structure of the extruded PTFE tubing during formation so that the resulting expanded tube has non- longitudinally aligned fibrils, thereby increasing both radial tensile strength as well as axial tear strength. U. S. Patent No. 4,743,480 shows one attempt to reorient the fibrils of a resultant PTFE tube by modifying the extrusion process of the PTFE tube.

Other attempts to increase the radial tensile, as well as axial tear strength of a microporous ePTFE tube include forming the tubular graft of multiple layers placed over one another. Examples of multi-layered ePTFE tubular structures useful as implantable prostheses are shown in U. S. Patent Nos. 4,816,338; 4,478,898 and 5,001,276. Other examples of multi-layered structures are shown in Japanese Patent Publication nos. 6-343,688 and 0-022,792.

While each of the above enumerated patents provides tubular graft structures exhibiting enhanced radial tensile strength, as well as enhanced axial tear strength, these structures all result in tubes exhibiting lower porosity. More specifically, the multi-layered ePTFE tubular structures of the prior art exhibit a smaller microporous structure overall, especially at the inner surface, and

accordingly, a reduction in the ability of the graft to promote endothelization along the inner surface.

5 It is therefore desirable to provide a ePTFE vascular graft which exhibits increased porosity especially at the inner surface thereof while retaining a high degree of radial strength especially at the external surface thereof.

It is further desirable to produce an ePTFE vascular graft which exhibits increased porosity at the outer surface thereof while retaining a high degree of radial tensile and suture retention strengths.

SUMMARY OF THE INVENTION:

10 It is an object of the present invention to provide an improved ePTFE vascular graft.

It is a further object of the present invention to provide a ePTFE vascular graft exhibiting an enhanced microporous structure while retaining superior strength.

15 It is a still further object of the present invention to provide an ePTFE tubular structure having an inner portion exhibiting enhanced porosity and an outer portion exhibiting enhanced radial tensile strength and suture elongation characteristics.

20 It is yet another object of the present invention to provide a multi-layered ePTFE tubular vascular graft having an inner layer which has a porosity sufficient to promote cell endothelization and an outer layer having a high degree of radial tensile strength.

It is an additional object of the present invention to provide a multi-layered ePTFE tubular vascular graft having an outer layer whose porosity is sufficient to promote enhanced cell growth and tissue incorporation, hence more rapid healing, and an inner layer having a high degree of strength.

5 In the efficient attainment of these and other objects, the present invention provides an implantable polytetrafluorethylene (PTFE) vascular graft. The graft includes a first ePTFE tubular structure, and a second ePTFE tubular structure circumferentially disposed exteriorly about the first tubular structure. The porosity and physical strength characteristics of each of the aforementioned
10 tubular structures can be varied independently of each other. This results in a structure whose first ePTFE tubular structure exhibits a porosity sufficient to promote cell endothelization there along, while the second structure exhibits strength in excess of the strength of the first tubular structure. Alternatively the first ePTFE tubular structure exhibits strength in excess of the strength of the
15 second tubular structure, while the second tubular structure exhibits a porosity sufficient to promote more rapid tissue incorporation.

As more particularly described by way of the preferred embodiment herein, the first and second PTFE tubular structures are formed of expanded polytetrafluorethylene (ePTFE). Further, the second ePTFE tubular structure is
20 adheringly supported over the first ePTFE tubular structure to form a composite tubular graft. The strength of this adhesion can be varied as desired to control the characteristics exhibited by the resultant composite structure.

In its method aspect, the present invention provides a method of forming a vascular graft. The method includes the steps of providing a first ePTFE tubular
25 structure having a desired porosity and strength combination. A second ePTFE tubular structure is provided, also having the desired porosity and strength combination. The second ePTFE structure is disposed over the first ePTFE so as to define a composite vascular graft.

The method of the present invention also provides for the positioning of an intermediate structure between the first and second ePTFE tubular structures. Examples of such structures include an additional ePTFE layer and fibers or thin films of PTFE or other suitable polymers. This intermediate structure also contributes to the resultant porosity and strength of the vascular graft.

BRIEF DESCRIPTION OF THE DRAWINGS:

Figure 1 is a schematic longitudinal cross-section of a multi-layer ePTFE vascular graft of the present invention.

Figure 2 is a longitudinal cross-section of an alternate embodiment of the present invention producing a multi-layer ePTFE vascular graft.

Figure 3 is a scanning electron micrograph showing a cross-sectional view of a vascular graft produced using the present invention.

Figure 4 is a perspective showing of one of the tubular structures of the graft of Figure 1 over-wrapped with a layer of ePTFE tape.

Figure 5 is a cross-sectional showing of an alternate embodiment of the ePTFE vascular graft of the present invention. In this instance, the view is taken through the lines II-II of the view shown in Figure 2.

DETAILED DESCRIPTION OF THE PREFERRED EMBODIMENTS:

The prosthesis of the preferred embodiments of the present invention is a multi-layered tubular structure which is particularly suited for use as an endoprosthesis or vascular graft. The prosthesis is formed of extruded polytetrafluoroethylene (PTFE) as PTFE exhibits superior biocompatibility. Further, PTFE is particularly suitable for vascular applications as it exhibits low

thrombogenicity. Tubes formed of extruded PTFE may be expanded to form ePTFE tubes where the ePTFE tubes have a fibrous state which is defined by elongated fibrils interconnected by spaced apart nodes. Such tubes are said to have a microporous structure, the porosity of which is determined by the distance
5 between the surfaces of the nodes, referred to as the internodal distance (IND). Tubes having a large IND (greater than 40 microns) generally exhibit long term patency as the larger pores promote cell endothelization along the inner blood contacting surface. Tubes having lower IND (less than 40 microns) exhibit inferior healing characteristics, however they offer superior radial tensile and
10 suture retention strengths desirable in a vascular graft. The present invention provides a composite tubular structure which promotes long term patency of the graft by providing for enhanced cell endothelization along the inner surface while exhibiting enhanced strength due to the presence of the outer layer.

Referring to Figures 1 and 2 of the drawings, composite graft 10 of the
15 present invention is shown. Graft 10 is a elongate tubular structure formed of PTFE. Graft 10 includes a pair of coaxially disposed ePTFE tubes 12 and 14, tube 12 being the outer tube and tube 14 being the inner tube. A central lumen 15 extends through composite graft 10, defined further by the inner wall 14a of inner tube 14, which permits the passage of blood through graft 10 once the graft is
20 properly implanted in the vascular system.

Each tube 12 and 14 may be formed in a separate extrusion process. The process for the paste extrusion of PTFE tubes is well known in the extrusion art. Once extruded, the tubes are expanded to form ePTFE tubes. As will be described
25 hereinbelow, the tubes are expanded using differing process parameters (rates, deformation levels, temperatures, etc) to develop the desired microporous structures. The specifically designed structure of the resulting composite tube has defined properties of strength and porosity which yield a graft 10 having long term patency and good healing characteristics as well as superior strength characteristics.

The present invention is designed to produce grafts with substantially different node/fibril structures with respect to the internal and external portions of the graft which are adjacent to the internal and external graft surfaces. As an example, the inner tube 14 is designed to have relatively high IND while the outer tube 12 is designed to have a lower IND. Further, a distinct porosity change is clearly defined at the interface 13 between tubes 12 and 14. The inner tube 14 having a higher IND to allow enhanced cell endothelization, while the outer tube 12 having a lower IND provides superior strength to the overall composite.

An electron micrograph of such a structure produced according to the present invention is shown in Figure 3. The disparate IND's between the inner tube 14 and outer tube 12 are clearly evident, along with the step change in IND at the interface 13 between the inner tube 14 and outer tube 12. In this example, the strength of the interface 13 has been established by the processing conditions described below to fully adhere the inner tube 14 and outer tube together, hence preventing relative motion and providing enhanced strength.

Graft 10 of the present invention may be formed by expanding a thin wall inner tube 14 at a relatively high degree of elongation, on the order of approximately between 400 and 2000% elongation preferably from about between 700% and 900%. Tube 14 is expanded over a cylindrical mandrel (not shown), such as a stainless steel mandrel at a temperature of between room temperature and 645°F, preferably about 500°F. Tube 14 is preferably but not necessarily fully sintered after expansion. Sintering is typically accomplished at a temperature of between 645°F and 800°F preferably at about 660°F and for a time of between about 5 minutes to 30 minutes, preferably about 15 minutes. The combination of the ePTFE tube 14 over the mandrel is then employed as a second mandrel, over which outer tube 12 is expanded. The ID of the outer tube 12 is selected so that it may be easily but tightly disposed over the OD of inner tube 14. The composite structure 10 is then sintered at preferably similar parameters. The level of elongation of outer tube 12 is lower than that of inner tube 14,

approximately between 200% and 500% elongation preferably about 400%. The expansion and sintering of outer tube 12 over the inner tube 14 serves to adheringly bond the interface 13 between the two tubes, resulting in a single composite structure 10.

5 As shown in Figure 3, the resulting composite structure has an inner surface defined by inner tube 14 which exhibits an IND of between 40 and 100 microns, spanned by moderate number of fibrils. Such microporous structure is sufficiently large so as to promote enhanced cell endothelization once blood flow is established through graft 10. Such cell endothelization enhances the long term
10 patency of the graft.

 The outer structure, defined by outer tube 12, has a smaller microporous structure, with IND of 15-35 microns and a substantial fibril density. Such outer structure results in an increase in the strength of the outer tube, and hence of the composite structure. Importantly, the outer surface defined by the outer tube 12
15 exhibits enhanced suture retention due to the smaller IND.

 Furthermore, the resulting composite structure exhibits a sharp porosity change between the outer tube 12 and inner tube 14. This sharp porosity transition is achieved by providing an inner tube 14 having generally a given uniform porosity therealong and then providing a separate outer tube 14 having a
20 resultant different porosity uniformly therealong. Thus a distinct porosity change is exhibited on either side of the interface 13 defined between inner tube 14 and outer tube 12.

 In addition, the forming process described above results in a bonded interface between inner tube 14 and outer tube 12. The interface exhibits
25 sufficient interfacial strength resulting from the direct sintering of the outer tube 12 over the inner tube 14 so as to assure complete bonding of the two tubes. The strength of the interface between the two tubes may be independently varied

through selection of processing conditions and relative dimensions of precursor extruded tubes 12 and 14 as desired to yield a range of performance.

The following examples serve to provide further appreciation of the invention but are not meant in any way to restrict the scope of the invention.

5

EXAMPLE I

A thin extruded tube having wall thickness of 0.41 mm and an inner diameter of 6.2 mm was expanded over a stainless steel mandrel at 500°F to 900% elongation. The ePTFE tube was then sintered at 660°F for 14 minutes, cooled, and removed from the oven. A second thin extruded tube having wall thickness of 0.45 mm and an inner diameter of 6.9 mm was expanded over the first tube/mandrel combination at 500°F and 400% elongation. The composite was then sintered at 660°F for 14 minutes, cooled and removed from the oven. The resultant composite tube had a wall thickness of 0.65 mm and ID of 5.8 mm.

10

EXAMPLE II

A thin extruded tube having wall thickness of 0.41 mm and an inner diameter of 6.2 mm was expanded over a stainless steel mandrel at 500°F to 700% elongation. The ePTFE tube was then sintered at 660°F for 14 minutes, cooled, and removed from the oven. A second thin extruded tube having wall thickness of 0.45 mm and an inner diameter of 6.9 mm was expanded over the first tube at 500°F and 400% elongation. The composite was sintered at 660°F for 14 minutes, cooled, and removed from the oven. The resultant composite tube had a wall thickness of 0.67 mm and an inner diameter of 5.8 mm.

15

20

25

Table I presents physical property data for a vascular graft of the type depicted in Example I described above. The composite graft was removed from the mandrel and subjected to standard testing of radial tensile strength and suture

hole elongation. The radial strength of the 900%/400% composite graft is equivalent to a single layer 400% elongation graft and substantially stronger than a single layer 900% elongation graft, despite an overall thinner wall dimension. Additionally, the superior strength of the composite graft is demonstrated by the higher elongation capable of being borne by the graft prior to failure. The lower suture hole elongation, indicative of a smaller tear being caused by suturing and tensioning at a fixed value of 100 grams is clearly demonstrated for the graft prepared by the method of the current invention.

TABLE I

Physical Property Measurement	400% Elongation Single Layer Graft	900%/400% Elongation Composite Graft	900% Elongation Single Layer Graft
Radial Tensile Strength (kg/mm ²)	0.48	0.48	0.2
Radial Strain at Break (%)	550	690	531
Suture Hole Elongation (%)	87	81	158
Wall Thickness	0.72	0.65	0.73

Referring now to Figures 4 and 5, a further embodiment of the present invention is shown. Tubular graft 20 is a composite structure similar to graft 10 described above. Graft 20 includes an outer tube 22 and an inner tube 24 formed generally in the manner described above. In order to further control the porosity and strength of the graft 20, especially at the interface between outer tube 22 and inner tube 24, an additional layer may be employed in combination with outer tube 22 and inner tube 24.

As specifically shown in Figures 4 and 5, an additional layer 26 may be employed between inner tube 24 and outer tube 22. Layer 26 may include a helical wrap of ePTFE tape 27 placed over inner tube 24. The additional layer 26, however, may also exist as a sheet, film, yarn, monofilament or multi filament wrap, or additional tube. The additional layer 26 may consist of PTFE, FEP, or other suitable polymer composition to obtain the desired performance characteristics. Layer 26 may be used to impart enhanced properties of porosity and/or strength to the composite graft 20. For example, an additional layer 26 of ePTFE tape 27 having a low IND and wrapped orthogonally to the length direction of graft 20 would increase the radial strength of the resultant composite graft. Similarly, a layer of ePTFE having a high IND would increase the porosity of the composite structure thereby further promoting cell endothelization and/or tissue ingrowth.

As shown in Figure 4, layer 26 is disposed between inner tube 24 and outer tube 22, and functions as an intermediate layer therein between. It is further contemplated that the additional layer may be employed over outer tube 22, or an additional layer may be used both over outer tube 22 and over inner tube 24.

Various changes to the foregoing described and shown structures would now be evident to those skilled in the art. Accordingly, the particularly disclosed scope of the invention is set forth in the following claims.

WHAT IS CLAIMED IS:

1. An implantable tubular prosthesis comprising:
an expanded polytetrafluorethylene (ePTFE) composite tubular structure including a clearly defined tissue contacting outer tube and concentrically adjacent inner tube, an inner surface of which is a blood contacting surface;
5 said outer and inner tubes each having a given porosity defined by node and fibril spacing of said expanded structure, said given porosity of said inner tube being different from said given porosity of said outer tube and wherein a distinct difference in porosity between said inner tube and said outer tube is defined on either side of an interface therebetween.

2. An implantable tubular prosthesis of claim 1 wherein said outer tube exhibits a radial strength in excess of the radial strength of said inner portion.

3. An implantable tubular prosthesis of claim 1 wherein said given porosity of said inner tube is greater than said given porosity of said outer tube.

4. An implantable polytetrafluorethylene (PTFE) tubular vascular prosthesis comprising:
a first PTFE tubular structure having a given radial strength; and
a second PTFE tubular structure circumferentially disposed externally
5 about said first tubular structure;
 said first PTFE tubular structure exhibiting a porosity sufficient to promote cell endothelization therealong and said second tubular structure exhibiting radial strength in excess of the radial strength of said first tubular structure.

5. A vascular prosthesis of claim 4 wherein said second PTFE tubular structure is adheringly supported over said first PTFE tubular structure.

6. A vascular prosthesis of claim 4 further including an additional structure formed over either said first PTFE tubular structure or over said second PTFE tubular structure.
7. A vascular prosthesis of claim 6 wherein said additional structure is interposed between said first PTFE tubular structure and said second PTFE tubular structure.
8. A vascular prosthesis of claim 7 wherein said additional structure exhibits a porosity which is less than said porosity of said first PTFE tubular structure.
9. A vascular prosthesis of claim 4 wherein said first PTFE structure is formed of expanded PTFE.
10. A vascular prosthesis of claim 4 wherein said second PTFE structure is formed of expanded PTFE.
11. A vascular prosthesis of claim 4 wherein said first and second PTFE structures are formed of expanded PTFE.
12. A vascular prosthesis of claim 11 wherein said first PTFE structure has a porosity greater than that of said second PTFE structure.
13. A vascular prosthesis of claim 12 wherein said additional structure exhibits a strength which is greater than the radial strength of said first PTFE structure.
14. A vascular prosthesis of claim 13 wherein said additional structure exhibits strength less than said strength of said second PTFE structure.
15. A vascular prosthesis of claim 7 wherein said additional structure is formed of a polymer composition.

16. A vascular prosthesis of claim 15 wherein said polymer composition is PTFE.
17. A method of forming a tubular vascular prosthesis comprising the steps of:
(a) providing a first PTFE tubular structure having a given porosity sufficient to promote cell endothelization and a given strength;
(b) providing a second PTFE tubular structure having a radial strength greater than the radial strength of said first PTFE tubular structure; and
(c) disposing said second PTFE tubular structure over said first PTFE tubular structure to define a composite structure.
18. A method of claim 17 further including the step of:
expanding said first PTFE tubular structure to form a first ePTFE structure.
19. A method of claim 18 further including the step of:
expanding said second PTFE tubular structure to form a second ePTFE structure.
20. A method of claim 19 wherein said steps of expanding said first PTFE tubular structure includes:
expanding said first PTFE tubular structure at an elongation of between about 400% and 2000%.
21. A method of claim 17 wherein said step of expanding said second PTFE tubular structure includes:
expanding said second PTFE tubular structure at an elongation of between 200% and 500%.
22. A method of claim 21 further including the steps of:
providing an additional structure; and

positioning said additional structure over either said first PTFE tubular structure or said second PTFE tubular structure, or both said first and second tubular structures.

23. A method of claim 22 wherein said positioning step includes:

disposing said additional PTFE tubular structure over said first PTFE tubular structure.

24. A method of claim 23 wherein said additional structure is formed of PTFE.

25. A method of claim 17 wherein said providing step (a) further includes:

forming said first PTFE tubular structure over a mandrel.

26. A method of claim 25 wherein said disposing step (c) includes:

forming said second PTFE tubular structure over said first PTFE structure and said mandrel.

FIG-1

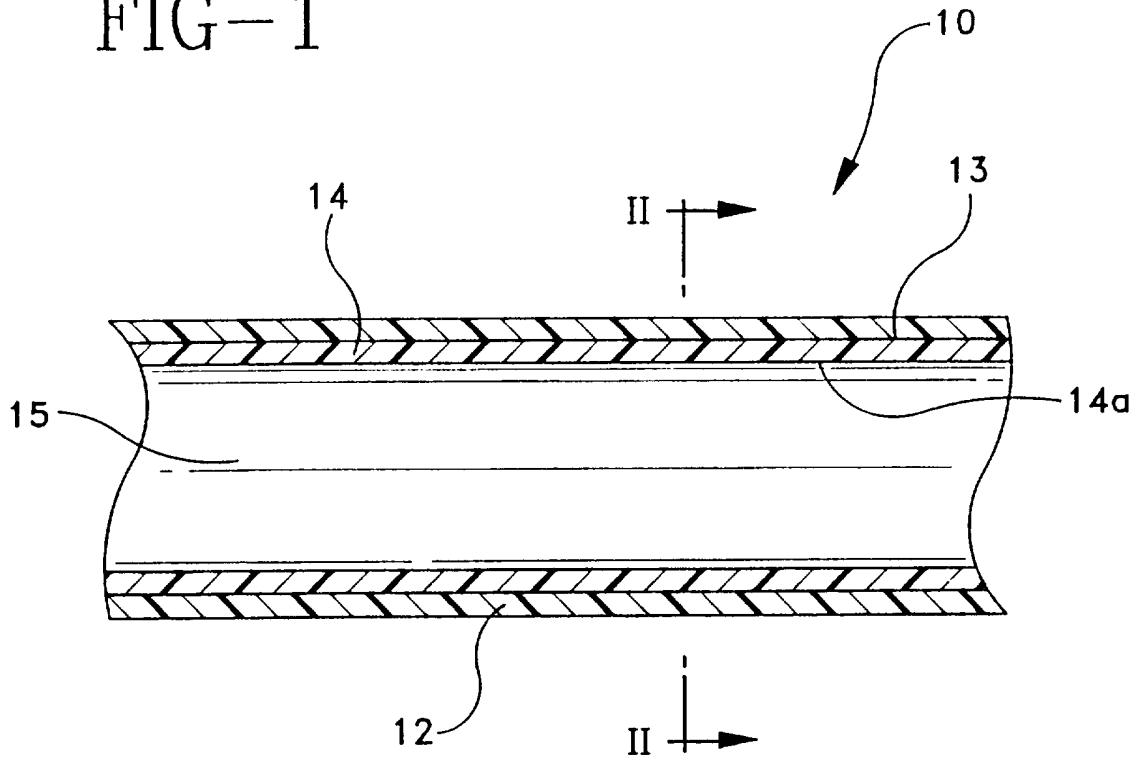

FIG-2

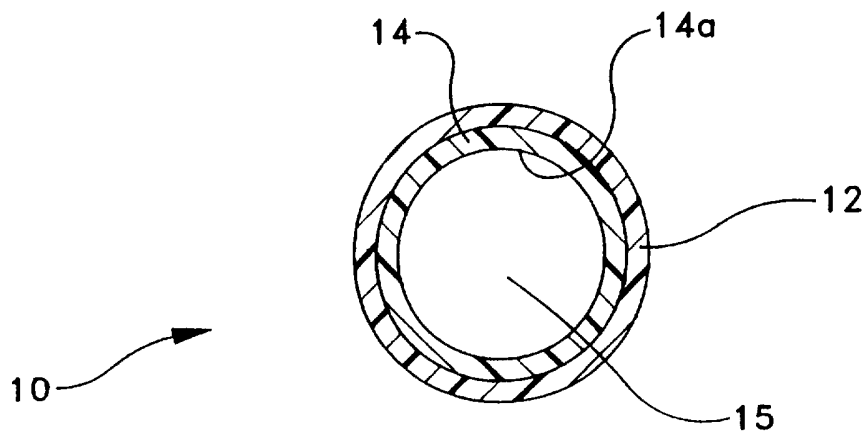

FIG-3

2/3

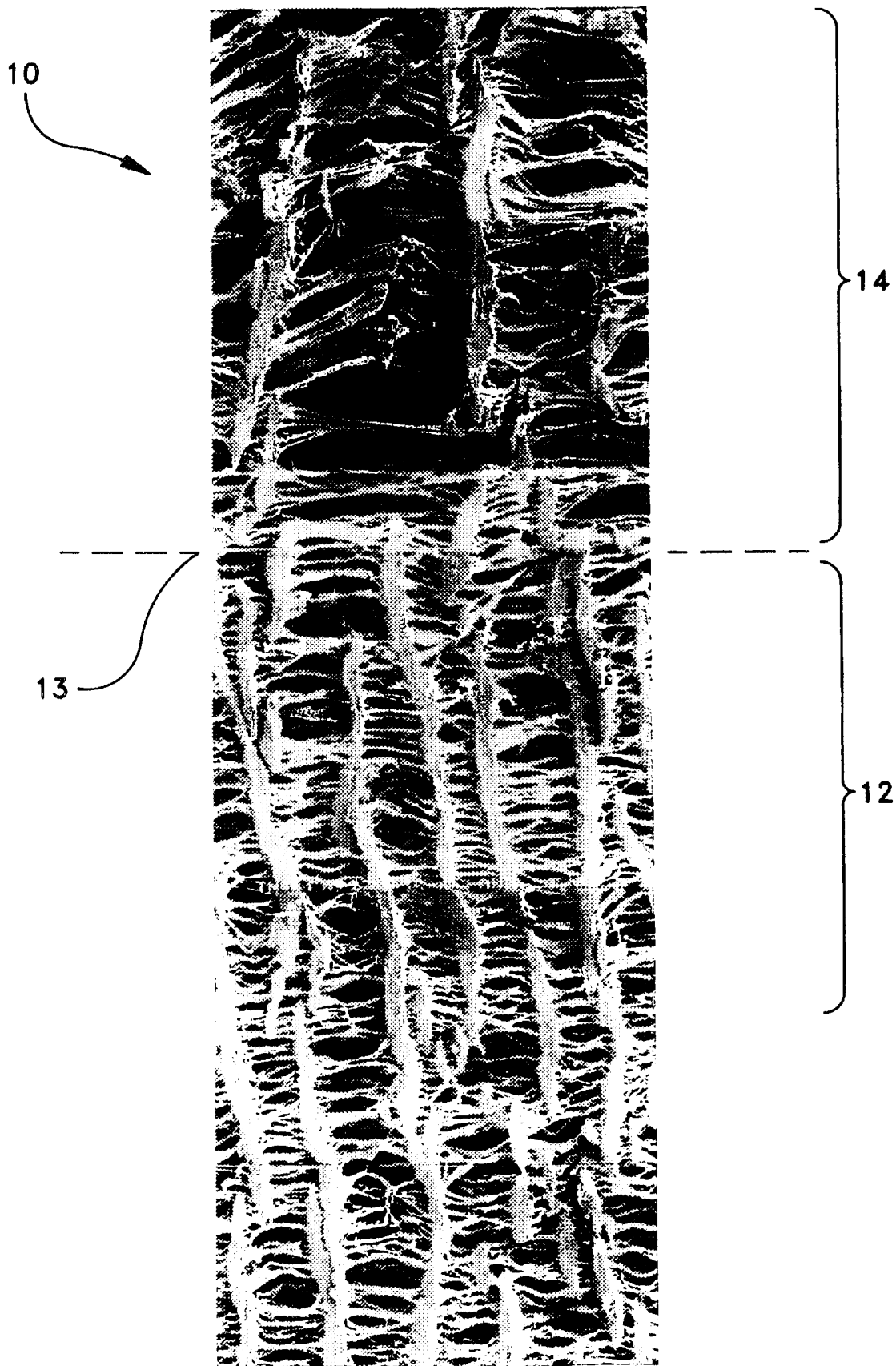

FIG-4

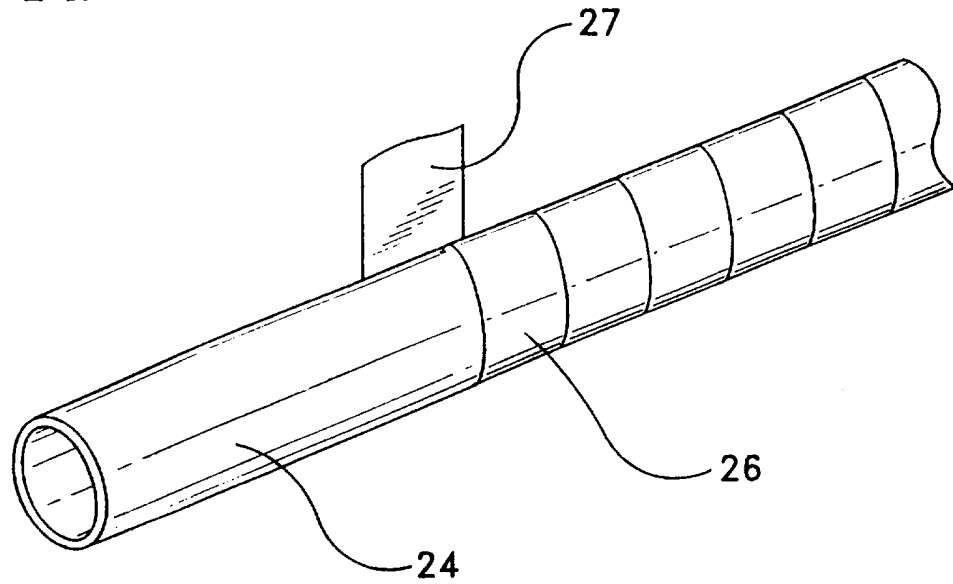
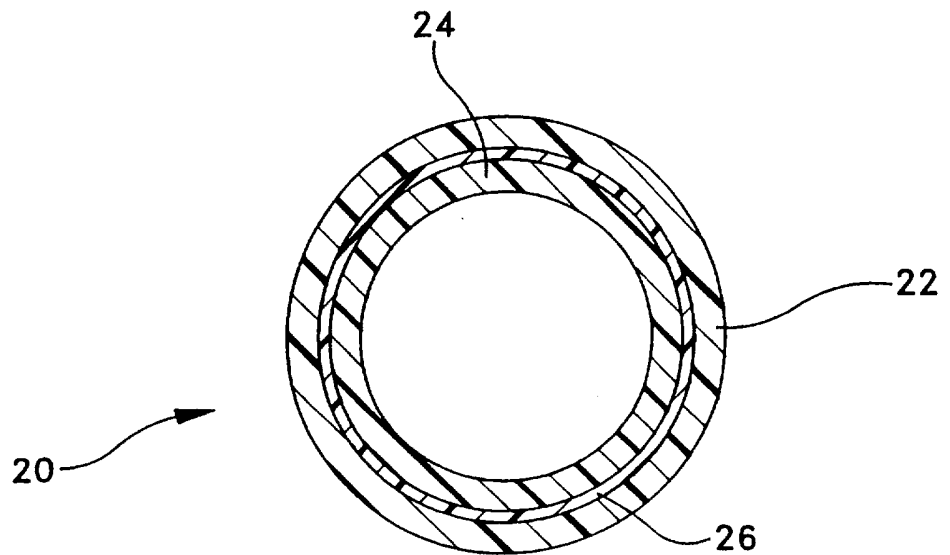

FIG-5



INTERNATIONAL SEARCH REPORT

International Application No

PCT/US 97/01720

A. CLASSIFICATION OF SUBJECT MATTER

IPC 6 A61F2/06

According to International Patent Classification (IPC) or to both national classification and IPC

B. FIELDS SEARCHED

Minimum documentation searched (classification system followed by classification symbols)

IPC 6 A61F

Documentation searched other than minimum documentation to the extent that such documents are included in the fields searched

Electronic data base consulted during the international search (name of data base and, where practical, search terms used)

C. DOCUMENTS CONSIDERED TO BE RELEVANT

Category *	Citation of document, with indication, where appropriate, of the relevant passages	Relevant to claim No.
A	WO 95 24304 A (MEADOX MEDICALS, INC.) 14 September 1995 see the whole document ---	1,4,17
A	PATENT ABSTRACTS OF JAPAN vol. 095, no. 003, 28 April 1995 & JP 06 343688 A (SUMITOMO ELECTRIC IND LTD), 20 December 1994, cited in the application see abstract ---	1,4
A	US 4 743 480 A (CAMPBELL ET AL) 10 May 1988 cited in the application see the whole document ---	1,4,17
A	WO 95 05277 A (W.L.GORE & ASSOCIATES, INC.) 23 February 1995 -----	

Further documents are listed in the continuation of box C.

Patent family members are listed in annex.

* Special categories of cited documents :

- *A* document defining the general state of the art which is not considered to be of particular relevance
- *E* earlier document but published on or after the international filing date
- *L* document which may throw doubts on priority claim(s) or which is cited to establish the publication date of another citation or other special reason (as specified)
- *O* document referring to an oral disclosure, use, exhibition or other means
- *P* document published prior to the international filing date but later than the priority date claimed

- *T* later document published after the international filing date or priority date and not in conflict with the application but cited to understand the principle or theory underlying the invention
- *X* document of particular relevance; the claimed invention cannot be considered novel or cannot be considered to involve an inventive step when the document is taken alone
- *Y* document of particular relevance; the claimed invention cannot be considered to involve an inventive step when the document is combined with one or more other such documents, such combination being obvious to a person skilled in the art.
- *&* document member of the same patent family

Date of the actual completion of the international search

22 May 1997

Date of mailing of the international search report

30.05.97

Name and mailing address of the ISA

European Patent Office, P.B. 5818 Patentlaan 2
NL - 2280 HV Rijswijk
Tel. (+ 31-70) 340-2040, Tx. 31 651 epo nl,
Fax (+ 31-70) 340-3016

Authorized officer

Smith, C

INTERNATIONAL SEARCH REPORT

Information on patent family members

International Application No
PCT/US 97/01720

Patent document cited in search report	Publication date	Patent family member(s)	Publication date
WO 9524304 A	14-09-95	US 5505887 A	09-04-96
		AU 1995095 A	25-09-95
		CA 2161449 A	14-09-95
		EP 0702620 A	27-03-96
		FI 955388 A	08-11-95
		JP 9500843 T	28-01-97

US 4743480 A	10-05-88	AU 5682990 A	27-09-90
		AU 600730 B	23-08-90
		AU 7417687 A	19-05-88
		CA 1311590 A	22-12-92
		DE 3778831 A	11-06-92
		EP 0267719 A	18-05-88
		GB 2197870 A	02-06-88
		JP 7015022 B	22-02-95
		JP 63139926 A	11-06-88
		US 4876051 A	24-10-89

WO 9505277 A	23-02-95	AU 6943794 A	14-03-95
		CA 2167943 A	23-02-95
		EP 0714345 A	05-06-96
		JP 9501585 T	18-02-97
		US 5620763 A	15-04-97
