

No. 639,622.

Patented Dec. 19, 1899.

W. H. SHAFFNER.
COMPRESSED AIR WATER ELEVATOR.

(Application filed Apr. 28, 1899.)

(No Model.)

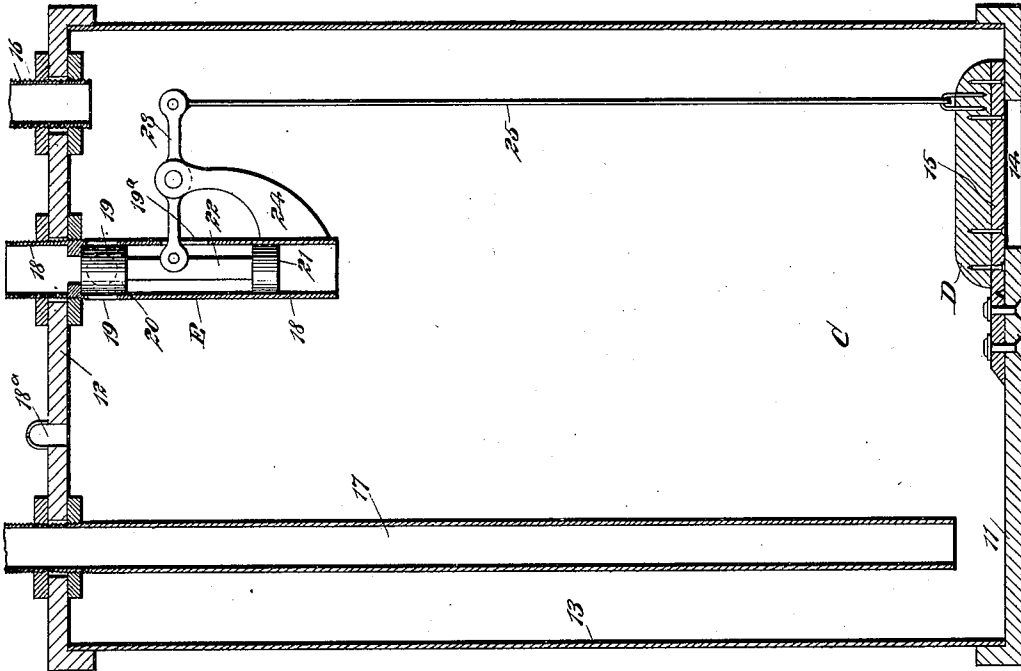

Fig. 2.

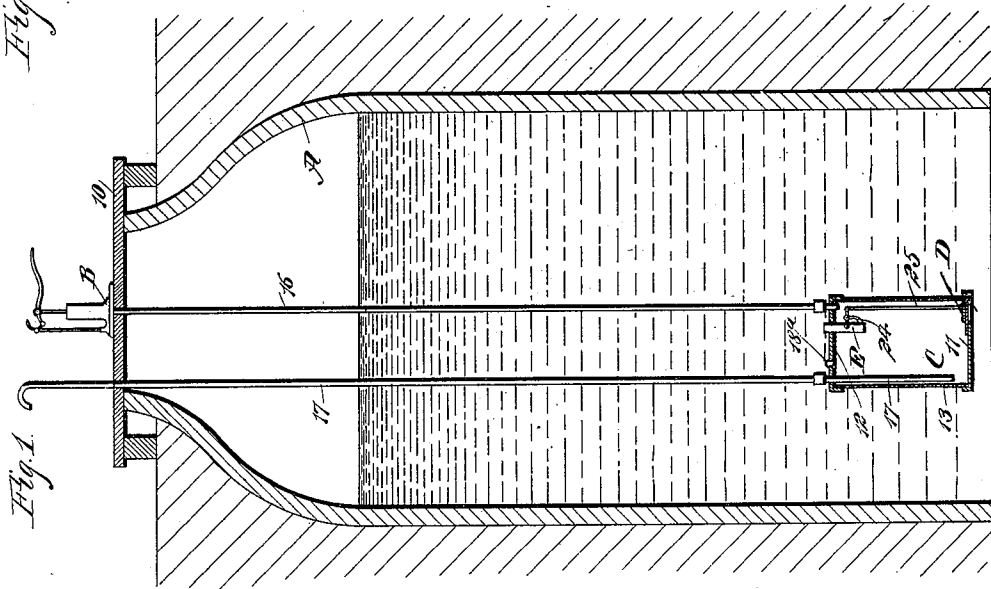

Fig. 1.

WITNESSES:

L. Almquist
J. Petersen

INVENTOR

William H. Shaffner

BY

Munn
ATTORNEYS.

UNITED STATES PATENT OFFICE.

WILLIAM HENRY SHAFFNER, OF LOUISIANA, MISSOURI.

COMPRESSED-AIR WATER-ELEVATOR.

SPECIFICATION forming part of Letters Patent No. 639,622, dated December 19, 1899.

Application filed April 28, 1899. Serial No. 714,882. (No model.)

To all whom it may concern:

Be it known that I, WILLIAM HENRY SHAFFNER, of Louisiana, in the county of Pike and State of Missouri, have invented a new and Improved Compressed-Air Water-Elevator, of which the following is a full, clear, and exact description.

The object of my invention is to provide a tank or supply-chamber adapted to be placed at or near the bottom of a well, cistern, or the like, and arranged to automatically receive a charge of water and to automatically regulate the escape of air when water is to enter said tank or chamber.

Another object of the invention is to provide a simple means for discharging water at an elevation from the tank or chamber, and to provide a connection between the water-inlet valve and the air-outlet valve of the tank or chamber.

The invention consists in the novel construction and combination of the several parts, as will be hereinafter fully set forth, and pointed out in the claims.

Reference is to be had to the accompanying drawings, forming a part of this specification, in which similar characters of reference indicate corresponding parts in both figures.

Figure 1 is a vertical section through a well and likewise a vertical section through the improved tank or chamber located within the well, showing the connections between the outlet for the water and the pump and supply tank or chamber in side elevation; and Fig. 2 is a longitudinal vertical section through the improved supply tank or chamber, the view being on an enlarged scale.

A represents a well or a cistern provided with a suitable top or cover 10, upon which an air-pump B is supported, and C represents a water-supply tank or chamber that is located within the well or cistern at any desired point below the normal water-level. This chamber or tank C consists of a bottom 11, a top 12, and a body portion 13, and is usually of cylindrical shape. A water-inlet 14 is provided in the bottom of said tank or chamber, and this water-inlet is normally closed by a valve D, said valve opening inward and having hinged connection with the inner face of the tank, as is particularly shown in Fig. 2; and the valve D is provided with a contact-face 15, of rubber,

leather, or a like material, the body of said valve being of metal or of wood.

Air under pressure is supplied to the tank or chamber C through the medium of a pipe 16, connected with the pump B, which pipe is made to enter the top portion of the tank or chamber, being attached thereto in both a liquid and an air-tight manner, and the water is conducted from the supply tank or chamber through the medium of a discharge-pipe 17, that extends within the said chamber or tank to a point near its bottom and out through the platform or cover 10 at the mouth of the well or cistern, as shown in Fig. 1. An air-outlet valve E is located in the top portion of the said supply tank or chamber, and this valve consists of a casing 18 in the form of a tube that extends out through the top of the tank or chamber, as is particularly shown in Fig. 2, the said casing having ports 19 produced therein adjacent to the inner surface of the head or top 12 of the chamber or tank C and with a slot 19^a below the said ports. Two piston-heads 20 and 21 are held to slide in the casing 18, said heads being connected by a bar 22, and when air is introduced into the tank or chamber C the upper piston 20 closes the ports 19 in the air-escape valve, and this is automatically accomplished by the seating of the water-inlet valve D, since a lever 23 is pivoted to the connecting-rod 22, extending through the slot 19 in the valve-casing. This lever is fulcrumed upon an arm 24, projected from the valve-casing, and the lever 23 is further connected, by a link or rod 25, with the valve D, as is shown in both views. A small air-vent 18^a is also preferably provided at the top portion of the supply chamber or tank. Normally the valve D is open, and the chamber or tank C is consequently filled with water, since in opening the valve D, which is done by the force of the water, the ports of the air-escape valve are likewise opened, and the chamber or tank will be rapidly filled. When water is needed at the surface, air is forced into the tank or chamber through the medium of the pump B and pipe 16, and owing to the pressure of the air upon the water the valve-D will be closed and the air-escape valve likewise closed, thus insuring the water passing up the stand or discharge pipe 17 to the point at which it is

to be delivered. As soon as the tank or chamber C is relieved from the pressure of air the column of water will force the inlet-valve D gradually open, thus gradually opening the 5 ports 19 of the air-escape valve E and permitting the air contained in the tank to gradually pass out at the upper portion of the valve-casing while the water enters proportionately at the inlet 14 until the said tank is eventually 10 filled with fluid.

Having thus described my invention, I claim as new and desire to secure by Letters Patent—

1. In a compressed-air water-elevator, a 15 tank or chamber adapted to be located below the water-level of a well or the like, said tank or chamber being provided with a water-inlet valve in its bottom said valve opening inward by the inward pressure of the entering water, 20 an air-escape valve at the top a connection between the inwardly-opening water-inlet valve and the air-valve, a water-discharge pipe, and an air-supply pipe adapted to receive air under pressure the water-inlet valve 25 being closed by the air-pressure acting on the water in the tank or chamber, for the purpose specified.

2. In a compressed-air water-elevator, a supply 30 tank or chamber adapted to be located within a well or cistern below the normal level of the water, said tank or chamber being provided with a water-inlet valve in its bottom said valve opening inward by the inward pressure of the entering water, an air-relief valve 35 at its top, a connection between the water-inlet valve and the air-relief valve, and means

for introducing air under pressure into the tank and for conducting the water therefrom, the water-inlet valve being closed by the air-pressure acting on the water in the tank or chamber, as and for the purpose specified. 40

3. In a compressed-air water-elevator, the combination, with a tank or chamber provided with a water-inlet valve in its bottom, 45 said valve opening inwardly, an air-escape valve located at the top portion of said tank or chamber, said valve consisting of a casing provided with ports within the said tank, the casing having an outlet above the top of the 50 tank, a piston mounted to slide in the casing and close the said ports, a lever connected with the piston, and a connection between the lever and the inlet-valve, of a stand-pipe extending through the upper portion of the tank or chamber to a point near its bottom, an air- 55 pump, and a pipe connection between the air-pump and upper portion of said tank or chamber, for the purpose specified.

4. In a water-elevating apparatus, a tank or chamber having a water inlet and an outlet, 60 means for supplying air under pressure to the tank, a valve commanding the water-inlet, said valve being held closed by the interior pressure in the elevator, an air-valve 65 commanding the air-outlet, and a connection between the water-valve and the air-valve, to actuate the air-valve by the movement of the water-inlet valve.

WILLIAM HENRY SHAFFNER.

Witnesses:

HENRY KUHLMANN,
W. H. GLENN.