





가 , 가 가 가

가 가 가

가

1 9

[ ]

4가 (400) (100), (200) (300) (500)

4가 (100.200.300,400) (600) 가

1a 2 가 가 (100) 1b (10) 1b

(200) (300) (20a)

(20b) 5 (610)

(200,300) (20) (60)

(60) (70)

가 (40,50)

1 가

(A) 1a

(80)

(B)

(200) 5 (100) (20,30)

(30)

(30) 가

2

가

(300) 5

(100)

(200) (30)

3

(30)

가

4

(40,50)

(400)

(100,200,300)

(100,200,300,400)

(beam)

(

180kg/cm<sup>2</sup>

가 가 )

4

(90)

가

PS

가 (100,200,300,400)

(91)가 가

가

4

4 가

[ ]

(100,200,300,400)

가

(400)

가

1200(W)×1500(H)

) 가 1.5 M

(100,200,300)

5

가

3가

(6

10)

(610)

(620)

(600)

)가

(B)

가 (610)

(620)

가

가

(600)

가

가

가

(A)

(91) (94)

(92)

(93)

가

가

(95)

7

가 , L

(96)

가 , 8

(99)

L

(97)

, L

(99)

[

, L

(98)

]

(100,200,300,400)

(600)

가

가

가

H

. H

, 9a , 9c

가 H H

가

( )

(100,200,300,400)

가

가

(610)

(600)

L

가 가

가 7 . 7  
L

L

7

(91)가

가

(500)

가 6 . 6  
가

1 가 가

(100)

(100) ,  
(200)

5

).

(

가

(100,300)

(610)가  
)가

(610)

(630) (640,beam)

, 9  
(650)





1a

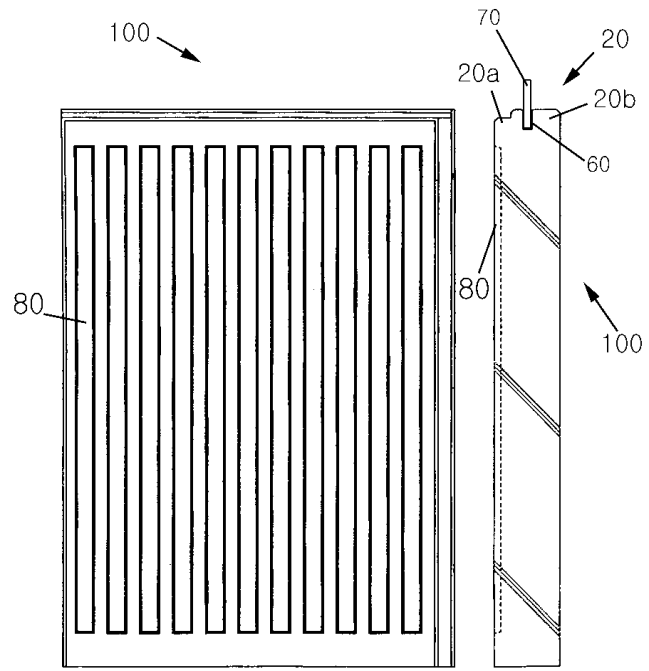

1b

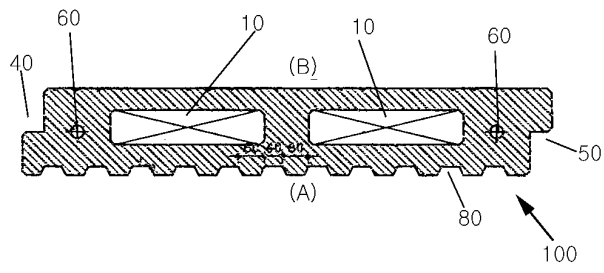

2

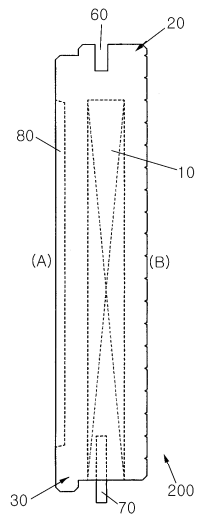



3

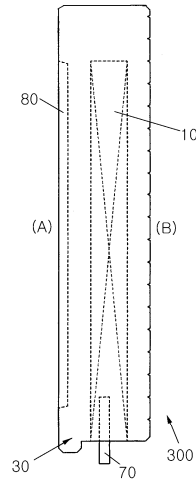

4

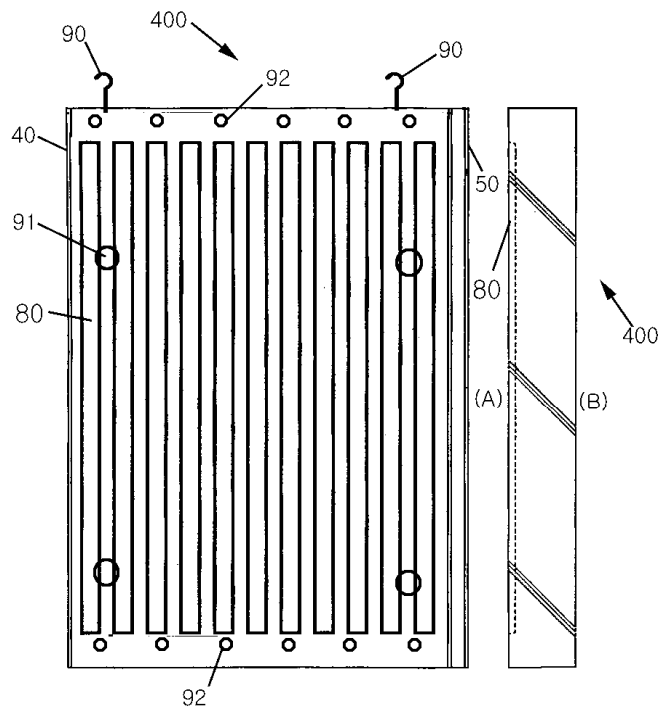

5

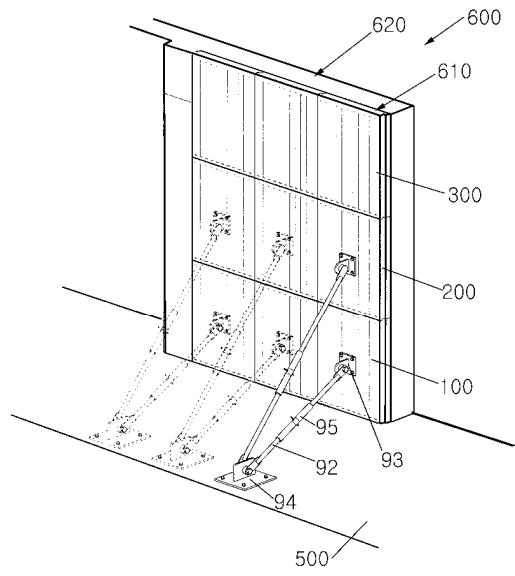

6

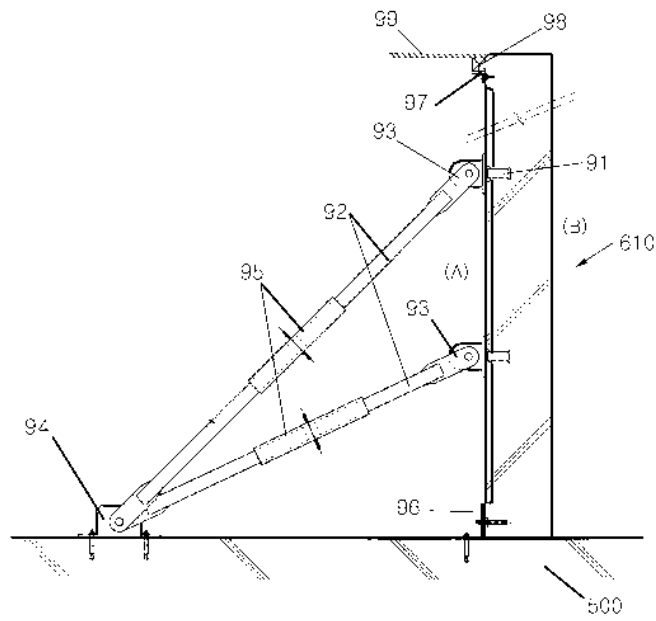

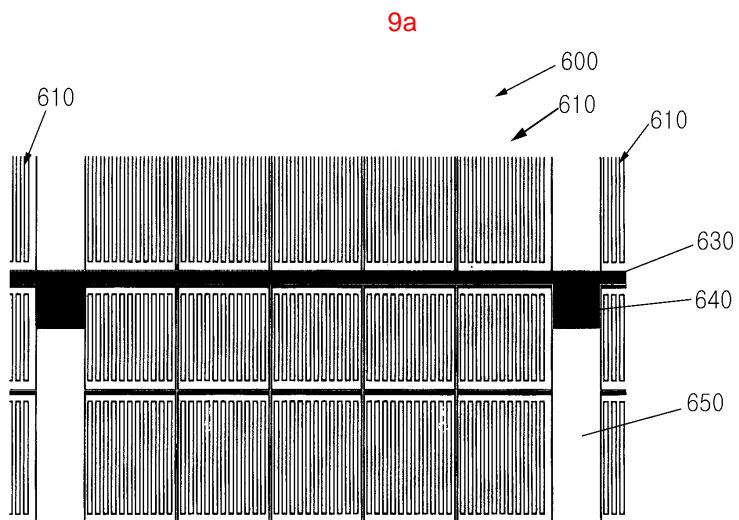
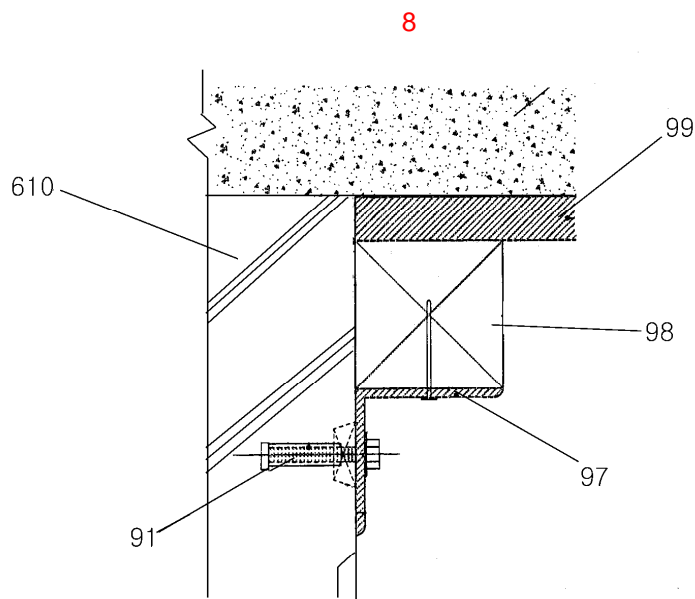
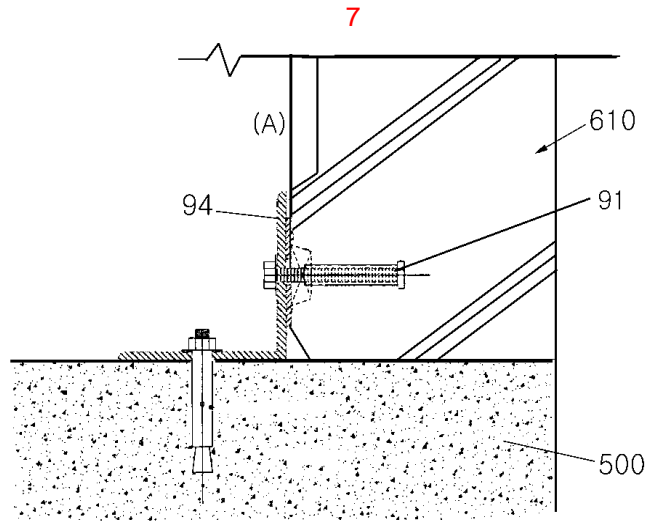

9b

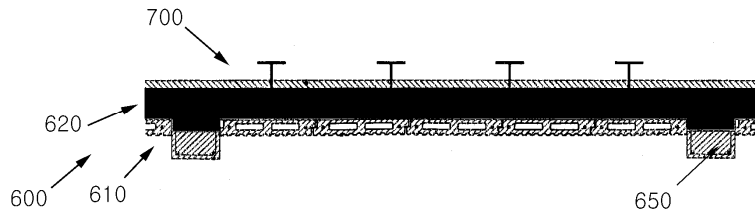

9c

