

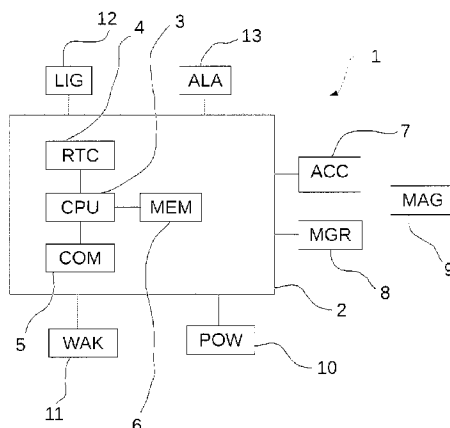

(86) Date de dépôt PCT/PCT Filing Date: 2015/07/21  
 (87) Date publication PCT/PCT Publication Date: 2017/01/26  
 (45) Date de délivrance/Issue Date: 2022/07/19  
 (85) Entrée phase nationale/National Entry: 2018/01/08  
 (86) N° demande PCT/PCT Application No.: IB 2015/001770  
 (87) N° publication PCT/PCT Publication No.: 2017/013463

(51) Cl.Int./Int.Cl. *A61M 5/315* (2006.01),  
*G16H 20/17* (2018.01)  
 (72) Inventeurs/Inventors:  
 MARCOZ, ALAIN, FR;  
 JEZ, EMMANUEL, FR;  
 DIOGO, SYLVAIN, FR;  
 GOURBET, PATRICE, FR;  
 PEREIRA, ALEXANDRE, FR;  
 POLLARD, MATHIEU, FR;  
 GILLET, KEVIN, FR  
 (73) Propriétaire/Owner:  
 BIOCORP PRODUCTION S.A., FR  
 (74) Agent: CASSAN MACLEAN IP AGENCY INC.

(54) Titre : SYSTEME DE REGLAGE DES DOSES POUR DISPOSITIFS D'ADMINISTRATION DE MEDICAMENTS INJECTABLES ET METHODES D'UTILISATION ASSOCIEES  
 (54) Title: DOSE CONTROL SYSTEM FOR INJECTABLE-DRUG DELIVERY DEVICES AND ASSOCIATED METHODS OF USE



(57) **Abrégé/Abstract:**

The present invention relates to a dose control system adapted for an injectable drug delivery device, the drug delivery device comprising a substantially elongate drug delivery body, at least one injectable drug held by the body, the body having a distal and proximal extremity, wherein the dose control system comprises three-dimensional magnetic field producing means for producing a magnetic field along three axes (x,y,z); magnetic field detection means configured to detect changes in at least the magnetic field produced by the three-dimensional magnetic field producing means; displacement detection means configured to measure a relative displacement or relative movement of the drug delivery device, and an integrated control unit, wherein the integrated control unit is connected to the magnetic field detection means, and to the displacement detection means, for processing information received from both the magnetic field detection means and the displacement detection means; wherein the three-dimensional magnetic field producing means is configured to effect a rotating coaxial displacement around, and along, a longitudinal axis of the drug delivery system; the magnetic field detection means are located along said longitudinal axis; and the three-dimensional magnetic field producing means is located at, or near, a proximal extremity of the body of the drug delivery device.

(12) INTERNATIONAL APPLICATION PUBLISHED UNDER THE PATENT COOPERATION TREATY (PCT)

(19) World Intellectual Property  
Organization  
International Bureau(10) International Publication Number  
**WO 2017/013463 A1**(43) International Publication Date  
26 January 2017 (26.01.2017)

## (51) International Patent Classification:

A61M 5/315 (2006.01) G01R 33/02 (2006.01)  
G01D 5/14 (2006.01)

## (21) International Application Number:

PCT/IB2015/001770

## (22) International Filing Date:

21 July 2015 (21.07.2015)

## (25) Filing Language:

English

## (26) Publication Language:

English

(71) Applicant: **BIOCORP PRODUCTION S.A.** [FR/FR];  
P.I.T. Lavour La Bechade, F-63500 Issoire (FR).(72) Inventors: **MARCOZ, Alain**; Espinasse Haut, F-63160  
Montmorin (FR). **JEZ, Emmanuel**; 20, rue Gabriel Piguet,  
F-63100 Clermont Ferrand (FR). **DIOGO, Sylvain**; 18  
Chemin de la Buissonnade, F-43360 Vergongheon (FR).  
**GOURBET, Patrice**; Lieu-dit Entraigue, F-63340 Nonette  
(FR). **PEREIRA, Alexandre**; 14 rue Saint Exupéry, F-  
63170 Perignat-les-Sarlieve (FR). **POLLARD, Mathieu**; 3  
allée des Coches d'Eau, F-63430 Pont du Château (FR).  
**GILLET, Kévin**; 3 Impasse des Noisetiers, F-63870 Or-  
cines (FR).(74) Agent: **THURGOOD, Alexander**; IP Galore, 4 rue Dur-  
ette, F-63500 Brenat (FR).(81) Designated States (unless otherwise indicated, for every  
kind of national protection available): AE, AG, AL, AM,  
AO, AT, AU, AZ, BA, BB, BG, BH, BN, BR, BW, BY,  
BZ, CA, CH, CL, CN, CO, CR, CU, CZ, DE, DK, DM,  
DO, DZ, EC, EE, EG, ES, FI, GB, GD, GE, GH, GM, GT,  
HN, HR, HU, ID, IL, IN, IR, IS, JP, KE, KG, KN, KP, KR,  
KZ, LA, LC, LK, LR, LS, LU, LY, MA, MD, ME, MG,  
MK, MN, MW, MX, MY, MZ, NA, NG, NI, NO, NZ, OM,  
PA, PE, PG, PH, PL, PT, QA, RO, RS, RU, RW, SA, SC,  
SD, SE, SG, SK, SL, SM, ST, SV, SY, TH, TJ, TM, TN,  
TR, TT, TZ, UA, UG, US, UZ, VC, VN, ZA, ZM, ZW.(84) Designated States (unless otherwise indicated, for every  
kind of regional protection available): ARIPO (BW, GH,  
GM, KE, LR, LS, MW, MZ, NA, RW, SD, SL, ST, SZ,  
TZ, UG, ZM, ZW), Eurasian (AM, AZ, BY, KG, KZ, RU,  
TJ, TM), European (AL, AT, BE, BG, CH, CY, CZ, DE,  
DK, EE, ES, FI, FR, GB, GR, HR, HU, IE, IS, IT, LT, LU,  
LV, MC, MK, MT, NL, NO, PL, PT, RO, RS, SE, SI, SK,  
SM, TR), OAPI (BF, BJ, CF, CG, CI, CM, GA, GN, GQ,  
GW, KM, ML, MR, NE, SN, TD, TG).

## Published:

— with international search report (Art. 21(3))

(54) Title: DOSE CONTROL SYSTEM FOR INJECTABLE-DRUG DELIVERY DEVICES AND ASSOCIATED METHODS OF USE

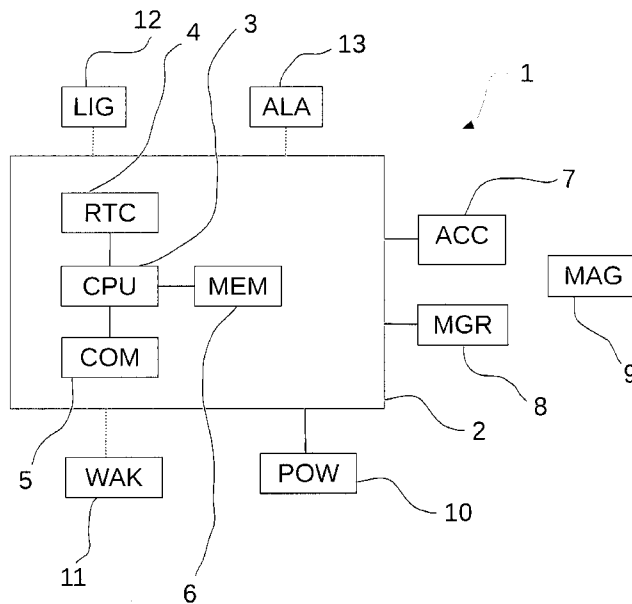

Fig. 1

(57) Abstract: The present invention relates to a dose control system adapted for an injectable drug delivery device, the drug delivery device comprising a substantially elongate drug delivery body, at least one injectable drug held by the body, the body having a distal and proximal extremity, wherein the dose control system comprises three-dimensional magnetic field producing means for producing a magnetic field along three axes (x,y,z); magnetic field detection means configured to detect changes in at least the magnetic field produced by the three-dimensional magnetic field producing means; displacement detection means configured to measure a relative displacement or relative movement of the drug delivery device, and an integrated control unit, wherein the integrated control unit is connected to the magnetic field detection means, and to the displacement detection means, for processing information received from both the magnetic field detection means and the displacement detection means; wherein the three-dimensional magnetic field producing means is configured to effect a rotating coaxial displacement around, and along, a longitudinal axis of the drug delivery system; the magnetic field detection means are located along said longitudinal axis; and the three-dimensional magnetic field producing means is located at, or near, a proximal extremity of the body of the drug del-

livery device.

## DOSE CONTROL SYSTEM FOR INJECTABLE-DRUG DELIVERY DEVICES AND ASSOCIATED METHODS OF USE

The present invention relates to the field of injectable-drug delivery devices, and in particular, to dose control systems provided for such injectable-drug delivery devices.

Delivery devices for injectable drugs have been known for many years. As demands have progressed and evolved for more patient responsibility in the management of their own individual treatments and medication plans, various drug delivery devices have been developed that allowed a user to self-inject their drug. This is particularly the case, for example, with insulin, intended to treat the consequences of diabetes. However, other drugs also fall into this category, required for example, to address potentially life-threatening situations, and enabling immediate emergency injection of a required drug, such as anaphylactic shock treatments, anti-coagulants, opioid receptor agonists and antagonists, and the like, to the extent that it has become a common occurrence for patients suffering from, or susceptible to, such ailments to carry these devices around with them.

One of the known problems with the existing self-injector systems was that of dosage control. In previous generations of injectable-drug delivery devices, such devices were equipped with mechanical means in order to attempt to prevent or limit excessive dose injections, or over use of the device, and the potentially serious consequences of such abuse, misuse, or simply user error. Additionally, it was felt desirable to be able to inform the user how much of the drug they had self-injected, so that there might be at least some visible cue as the injected amounts, thereby facilitating management of the treatment regime.

The main problems associated with the mechanical solutions proposed was that the necessarily over-complexified the structure of the drug deliver devices, and quite often imposed a very strict or complicated modus operandi on the user, which often could be different to that to which the user was accustomed, thereby leading to yet further manipulation errors, lost drug doses, patient non-compliance, and numerous other difficulties.

To counter these difficulties, attempts were made to address the complex nature of purely mechanical solutions involving moving mechanical parts and mechanical interactions of small and fragile components, through the use of contactless sensors and an information processing system built into the device to indicate the frequency and dose amounts of injectable drug administered, wasted, purged or otherwise expelled from the drug delivery device. This led to multiple different technical solutions, however, each one was geared to the specifics of the

particular manufacturer's corresponding range of injectable-drug delivery devices.

For example, in US8708957B2, a drug delivery device for self-injection of an injectable drug is disclosed comprising a sensor which is adapted to generate pulses during injection as the delivery movements progress. The number of pulses accumulated during dose delivery correspond to the size of the dose being delivered, whereas the frequency of the detected pulses is proportional to the dose speed during injection.

In other embodiments, the sensor circuitry can include position sensors adapted to monitor specific components of the drive mechanism which move during injection. The position sensors can be either linear sensors or rotary sensors, the particular choice of sensors being selected in accordance with the specific design of the dose setting and injection mechanism. For example, a linear position sensor can be provided that monitors the movements of the piston rod during injection. Alternatively, position sensors are provided which record the movements of a component which moves in synchronism with the piston rod during injection. For example, a component being rotatably mounted in the device and which rotates during injection may be monitored by a rotary position sensor whereby the dosing speed may be calculated from the rotary movement of the rotatably mounted component during injection.

EP1646844B2 discloses an injection device for administering and injectable drug, the device comprising a non-contact measuring unit for measuring a position between elements of a dosing device, and which can be moved relative to one another, the measuring unit comprising a magneto-resistive sensor, fixed to a first element, opposite a second magnetizable element, movable relative to the first element, and embodied as a rotational element for measuring rotational position ; and a magnetic device formed from a permanent magnet on the first element, and a second magnetizable element with a predetermined surface profile such that when the first and second elements are moved relative to each other, a surface of the second element changes its distance from the permanent magnet of the first element, whereby a measurable change in resistance is generated in the magneto-resistive sensor due to the change in magnetic field. This is a fairly complex system with many additional moving parts built into the barrel, or body, of the injectable-drug delivery device, leading to a greater risk of potential failure of the various components, or potentially interfering interaction between the movements of the magnet and magnetizable elements, and the respective signals generated.

EP2428238A1 discloses an apparatus apparatus for measuring a dose in an injector,

comprising a number sleeve that passes through an injector body and is connected to the injector body to be spirally movable, a pattern for dose measurement being formed on an outer periphery of the number sleeve; and the injector body comprising a sensor for sensing the pattern formed on the number sleeve when the number sleeve performs a spiral movement; and a controller for measuring a dose according to a spiral movement distance of the number sleeve through the sensor. In this device, a magnet is displaced spirally along the body of the drug delivery device, which is provided with corresponding sensors located at various points along and around the longitudinal axis of the body of the drug delivery device. Once again, this solution is extremely complex, and adds further complexity to an already complex drug delivery device.

WO 02/064196 A1 discloses an injection apparatus controlled by a closed switch unit comprising integrated sensors which monitor selected parameters of the apparatus. The closed switch unit is fixed within the injection apparatus. At least two pairs of integrated Hall elements are used as the sensors. The Hall elements co-operate with a magnetized ring which alternately exhibits north and south poles. The ring is arranged within a dosing means and is moved around the longitudinal axis of the injection apparatus in accordance with a rotational movement for setting a product dosage. In order to measure the volume of a dosage setting, it is necessary to determine the rotational movement of the magnetic ring relative to the closed switch unit.

US20060175427A1 discloses an injection apparatus comprising at least one passive, non-contact sensor which can generate signals for detecting the position of a setting element, the at least one passive, non-contact sensor comprising a magnetic switch or Reed contact. According to some embodiments of the present invention, a passive component such as a magnetic switch or Reed contact may be used as the sensor, as opposed to using active components, such as optical recorders or Hall sensors. No power flows when the passive sensor is in its resting state due to the circuit being interrupted by the magnetic switch or Reed contact. The passive, non-contact sensor generates digital signals, i.e. ON and OFF, which switch on or activate a measuring circuit and switch it off again, in order to detect the position of a setting element by counting the switching-on and switching-off processes. The position of a setting element such as a rotational position of a dosing unit can be detected without energy, such as power, in order to ascertain whether a setting element has been altered or not.

WO2013050535A3 discloses a system comprising a sensor assembly adapted to measure a magnetic field, and a moveable element adapted to be moved relative to the sensor assembly

between two positions by a combined axial and rotational movement, the rotational movement having a pre-determined relationship to the axial movement. A magnet is mounted to the moveable element and configured to generate a spatial magnetic field which relative to the sensor assembly varies corresponding to both the axial and rotational movement of the magnet and thus the moveable element. A processor is configured to determine on the basis of measured values for the magnetic field an axial position of the moveable element. In this system, a magnetic field producing means is located on a longitudinal drive screw that is located within the body of the injectable-drug delivery device, and the sensors are located along a longitudinal axis of said drug delivery device. It is noted that the whole of this system is located once again within the main body of the drug delivery device, in order for the magnetic field to be generated as close as possible to the longitudinal axis along which the magnet moves, and the sensors.

WO2014161954A1 discloses a drug delivery system, wherein the housing of the drug delivery device further comprises, integrated inside said housing, a first rotational member adapted to rotate relative to the housing corresponding to a set and/or expelled dose and comprising a first force transmitting surface, a second rotational member adapted to rotate relative to the housing corresponding to a set and/or expelled dose and comprising a second force transmitting surface, wherein at least portions of the first and second force transmitting surfaces are adapted to engage each other during setting and/or expelling of a dose, wherein the first rotational member comprises a magnet producing a magnetic spatial field which varies corresponding to the rotational movement of the first rotational member, and wherein the first rotational member is fully formed from a polymeric material containing magnetic particles, the polymeric material having been magnetized to provide a magnet producing the magnetic spatial field.

All of the above solutions involve a fairly complex arrangement of various sensors and/or organisation of elements within the body of the drug delivery device, which moreover generally imply having to modify said drug delivery device fairly substantially.

Accordingly, it is an object of the invention to provide a dose control system that can function with any of the currently available injectable-drug delivery devices, but which will also function with future designs of such injectable-drug delivery devices, where they rely on the general pen-shape auto-injector design, in which the drug delivery device comprises a substantially elongate drug delivery body, at least one injectable drug held by the body, the body having a distal and proximal extremity. Additionally, it is another object of the present

invention to provide such a dose control system which does not require substantial modification of the injectable-drug delivery device or the way in which it functions for the user, i.e. its modus operandi, when compared to a like, off-the-shelf drug delivery device. It is yet another object of the present invention to provide a dose control system that is removably mounted on said injectable-drug delivery devices, such that the drug delivery devices can be exchanged, for example, in case of damage to the drug delivery device or malfunction in the drug delivery device, or simply because some drug delivery devices are configured to only deliver a small range of available doses of drug, and it is desirable to be able to switch to another drug delivery device that has a different range of available doses of drug. These and other objects will become apparent from the various embodiments as indicated and detailed hereinafter.

Accordingly, one embodiment of the present invention is a dose control system adapted for an injectable drug delivery device, the drug delivery device comprising a substantially elongate drug delivery body, at least one injectable drug held by the body, the body having a distal and proximal extremity, wherein the dose control system comprises:

- three-dimensional magnetic field producing means for producing a magnetic field along three axes (x,y,z);
- magnetic field detection means configured to detect changes in at least the magnetic field produced by the three-dimensional magnetic field producing means;
- displacement detection means configured to measure a relative displacement or relative movement of the drug delivery device, and
- an integrated control unit, wherein the integrated control unit is connected to the magnetic field detection means, and to the displacement detection means, for processing information received from both the magnetic field detection means and the displacement detection means;

wherein:

- the three-dimensional magnetic field producing means is configured to effect a rotating coaxial displacement around, and optionally along, a longitudinal axis of the drug delivery system;
- the magnetic field detection means are located along said longitudinal axis; and
- the three-dimensional magnetic field producing means is removably located at, or near, a

proximal extremity of the body of the drug delivery device.

According to another embodiment of the dose control system of the invention, said dose control system is removably mounted to an exterior peripheral surface of said injectable drug delivery device.

According to yet another embodiment of the dose control system of the invention, the drug delivery device comprises a dose selector shaft, and the three-dimensional magnetic field producing means is mounted around said dose selector shaft at a proximal extremity thereof.

In yet another embodiment of the present invention, the dose selector shaft is configured to operate a displacement of the three-dimensional magnetic field producing means relative to the drug delivery device, whereby said three-dimensional magnetic field producing means is configured to move both in a proximal direction away from, and in a distal direction towards, the body of the drug delivery device.

In another embodiment according to the invention, the magnetic field detection means and the displacement detection means are removably mounted on the body of the drug delivery device.

In still yet another embodiment of the dose control system according to the invention, the magnetic field detection means and the displacement detection means are removably mounted on the body of the drug delivery device, substantially at a distal extremity thereof.

In yet another embodiment according to the invention, the magnetic field detection means is further configured to detect the earth's magnetic field (EMF).

In another embodiment of the present invention, the magnetic field detection means comprises at least one magnetometer.

According to another embodiment of the present invention, the magnetic field detection means comprises at least two magnetometers.

In yet another embodiment of the present invention, the magnetic field detection means comprises at least a first and second magnetometers, wherein the first magnetometer and the second magnetometer are configured to operate in parallel, both magnetometers simultaneously detecting any changes in magnetic field, as the three-dimensional magnetic field producing means is displaced proximally away from or distally towards them.

According to yet another embodiment, the magnetic field detection means comprises at least a

first and second magnetometers, wherein the first magnetometer and the second magnetometer are configured to operate in series, whereby the first magnetometer detects changes in magnetic field until a predetermined value of magnetic field is detected, and then the second magnetometer is activated to detect changes in magnetic field beyond said predetermined value, as the three-dimensional magnetic field producing means is displaced proximally away from or distally towards them.

In still yet another embodiment of the invention, the displacement detection means comprise at least one accelerometer configured to detect:

- the relative movement of acceleration caused by a vibration of the dose selector shaft; and/or
- a positional movement of the drug delivery device between an injection position and a purge position.

In a further embodiment of the invention, the dose control system further comprises communication means configured to enable communication of information from the integrated control unit with a remote and/or local data processing system.

In yet another embodiment of the invention, the remote and/or local data processing system comprises a smartphone application.

In still another embodiment of the invention, the dose control system further comprises a unique identifier that is communicated to the remote and/or local data processing system.

In another embodiment of the invention, the dose control system further comprises temperature detection means.

In another embodiment of the invention, the dose control system further comprises time determination means.

In a further embodiment of the invention, the dose control system further comprises autonomous power supply means.

In still yet another embodiment of the present invention, said dose control system is configured to permit an unhindered or unchanged modus operandi of said drug delivery system when compared to an off the shelf injectable-drug delivery device.

In yet another embodiment of the present invention, said magnetic field detection means, said displacement detection means, said integrated control unit, said autonomous power supply means, and said communication means are all located within a first removably mountable

housing configured to removably be mounted on, and encase the body of said injectable-drug delivery device, and said three-dimensional magnetic field producing means is located within a second housing configured to removably be mounted on, and surround the dose selector shaft of said body of said injectable-drug delivery device.

In yet another embodiment according to the present invention, there is provided a method for improving observance of treatment in an injectable drug administration regime, said method comprising:

- providing a dose control system removably mounted to an exterior peripheral surface of an injectable drug delivery device comprising a substantially elongate drug delivery body, at least one injectable drug held by the body, the body having a distal and proximal extremity;
- determining a dose set by the user via manipulation of the dose control system; and
- determining an operational status of the drug delivery device;
- relaying information obtained from said dose determination or said operational status determination to a remote and/or local data processing system.

In yet another embodiment, the method for improving observance of treatment in an injectable drug administration regime, said method further comprises:

- validating an actual injected dose of injectable drug.

In still yet another embodiment, the method for improving observance of treatment in an injectable drug administration regime, comprises a determination of a user-set dose, wherein said determination is effected by:

- rotating a three-dimensional magnetic field producing means, removably mounted on a dose selector shaft, around a longitudinal axis of said body of the drug delivery device;
- detecting changes in magnetic field produced in at least two orthogonal dimensions, and preferably in three orthogonal dimensions (x,y,z) via magnetic field detection means removably mounted on the body of the drug delivery device;
- correlating, via an integrated control unit, the changes in magnetic field detected by the magnetic field detection means, with an angular position of the rotated three-dimensional magnetic field producing means;
- correlating said angular position to a corresponding dose.

In another embodiment of the method for improving observance of treatment in an injectable drug administration regime, a determination of an operational status of the drug delivery device comprises one or more of the following:

- detecting a positional movement of the drug delivery device via displacement detection means removably mounted on the body of the drug delivery device to determine whether the device is in a purge position, or an injection position;
- detecting a temperature of the drug held by the body of the drug delivery device via temperature detection means and determining whether said temperature is within acceptable operating limits for an administration of the drug;
- detecting a level of autonomous power supply; and
- detecting whether the dose control system is in a hibernated or awake state.

In yet another embodiment of the method for improving observance of treatment in an injectable drug administration regime, wherein a validation of an actual injected dose of injectable drug is effected by:

- detecting a validation of a dose setting via displacement detection means removably mounted on the body of the drug delivery device, said validation being created by a clicking action of the user on a distal extremity of the dose selector shaft;
- measuring elapsed time between said clicking action of the user and actual injection of the drug;
- correlating the elapsed time between said clicking action of the user and the time at which actual injection occurs with an acceptable set of stored values to validate the selected dosage as the actual injected dosage of injectable drug.

In still yet another embodiment, the method for improving observance of treatment in an injectable drug administration regime is further defined wherein a determination of a user-set dose is effected by:

- rotating the three-dimensional magnetic field producing means, removably mounted on a dose selector shaft, around a longitudinal axis of said body of the drug delivery device, wherein each rotatory movement generates a series of one or more audible clicks, each rotational click also producing a vibration and corresponding relative displacement movement in the device;

- the relative displacement movements in the device produced by each rotational click being detected by the displacement detection means.

In another embodiment of the method for improving observance of treatment in an injectable drug administration regime, each rotational click of the dose selector shaft corresponds to a rotational displacement of the magnetic field producing means around the longitudinal axis of the device.

In still yet another embodiment of the method for improving observance of treatment in an injectable drug administration regime, the displacement detection means have a maximum resolution comprised between 1 Hz and 2 KHz.

In yet a further embodiment of the method for improving observance of treatment in an injectable drug administration regime, the displacement detection means are configured to detect accelerational displacements of from about 0.5G to about 16G.

In another embodiment of the method for improving observance of treatment in an injectable drug administration regime, the magnetic field detection means are configured to detect changes in magnetic field of from about 0.5 gauss to about 32 gauss.

As mentioned in the various embodiments of the invention, the dose control system comprises means for producing a three-dimensional magnetic field. The magnetic field producing means produces a magnetic field that extends over three mutually perpendicular axes, x, y and z. As will be seen with regard to the detailed description of the invention, this three-dimensional magnetic field is used to calculate an angular rotational position in the dose control system of the magnetic field producing means in relation to the longitudinal axis of the body of the injectable-drug delivery device, and when that angular rotational position is known, calculate the corresponding dose.

Various means for producing a magnetic field can be used in the present invention, for example, classical magnets, electromagnets, mixed material material magnets, and the like all of which are generally known in the art. Such magnets are typically made from magnetizable materials, having magnetic or paramagnetic properties, whether naturally or when an electric or other energizing flow traverses or affects said material to produce or induce a magnetic field in said material. Suitable materials can be appropriately selected from :

- ferrite magnets, especially sintered ferrite magnets, for example, comprising a crystalline compound of iron, oxygen and strontium ;

- composite materials consisting of a thermoplastic matrix and isotropic neodymium-iron-boron powder ;
- composite materials made up of a thermoplastic matrix and strontium-based hard ferrite powder, whereby the resulting magnets can contain isotropic, i.e. non-oriented, or anisotropic, i.e. oriented ferrite particles ;
- composite materials made of a thermo-hardening matrix and isotropic neodymium-iron-boron powder ;
- magnetic elastomers produced with, for example, heavily charged strontium ferrite powders mixed with synthetic rubber or PVC, and subsequently either extruded into the desired shape or calendaring into fine sheets ;
- flexible calendered composites, generally having the appearance of a brown sheet, and more or less flexible depending on its thickness and its composition. These composites are never elastic like rubber, and tend to have a Shore Hardness in the range of 60 to 65 Shore D ANSI. Such composites are generally formed from a synthetic elastomer charged with strontium ferrite grains. The resulting magnets can be anisotropic or isotropic, the sheet varieties generally having a magnetic particle alignment due to calendaring ;
- laminated composites, generally comprising a flexible composite as above, colaminated with a soft iron-pole plate ;
- neodymium-iron-boron magnets ;
- steels made of aluminium-nickel-cobalt alloy and magnetized ;
- alloys of samarium and cobalt.

Of the above list of magnetic field producing means, those comprising a polymer matrix, e.g. a thermopolymer matrix, and magnetic or magnetizable particles embedded therein, have been found to give particularly good results, as they can be injection moulded into various desired configurations, and provide a magnetic field of suitable strength, which for the present invention is a magnet producing a magnetic field of between approximately 0.5 gauss and about 32 gauss. These products are generally also known as plastomagnets, a range of which are available from Arelec (France).

As will be seen in the detailed description given hereafter, the three dimensional magnetic field producing means are substantially annular shaped. By “substantially annular shaped”, it

is to be understood that the magnetic field producing means defines a general ring shape, which could be circular, ellipsoid, or even any suitable polygonal shape. In some instances, the magnetic field producing means could be made up of one or more separate or discontinuous segments of magnetic field producing material, for example, arcuate, quarter-spherical, or hemi-spherical, each with at least one pair of opposing magnetic poles. It is however preferred that the substantially annular ring shaped three-dimensional magnetic field producing means be made of a single block of magnetic or magnetizable material, and whilst it is possible to provide a multipolar block of magnetic field producing means, it is preferred to have only two magnetic poles, one being the opposite in polarity of the other, in the three-dimensional magnetic field producing means.

The three-dimensional magnetic field producing means of the present invention is configured to effect a rotating coaxial displacement around, and optionally along, a longitudinal axis of the drug delivery system. The rotating displacement coincides with that of a dose selector shaft, meaning that turning the magnetic field producing means around the longitudinal axis causes said shaft to rotate in the same direction, and to generate a clicking sound.

Additionally, as is generally applicable to drug delivery devices equipped with such dose selector shafts, the magnetic field producing means can translate longitudinally with the dose selector shaft away, i.e. proximally, from the proximal extremity of the body of the drug delivery device, when increasing the dose to be injected. Conversely, the magnetic field producing means will rotate in the opposite direction and can translate longitudinally along the longitudinal axis of the device distally, back towards the proximal extremity of the device as the dose is reduced. In another embodiment according to the invention, the dose selector shaft is not configured to enable longitudinal translation, meaning that the dose selector shaft is simply configured to rotate about the longitudinal axis, and that this rotational movement defines the doses selected, whether clockwise or counter-clockwise. The dose control system can accordingly be adapted to such a drug delivery device also.

In addition, the magnetic field producing means is dimensioned to provide sufficient magnetic field to be detected by the magnetic field detection means, but also so as to not add extra volume to the dose control system, and thereby hinder the user or usage of the drug delivery device in normal operation when compared to a drug delivery device that has no such dose control system according to the invention.

In the dose control system according to the present invention, magnetic field detection means are present and configured to detect changes in at least the magnetic field produced by the

three-dimensional magnetic field producing means. Additionally, said magnetic field detection means can also be configured to detect the earth's magnetic field (EMF), which is always present on earth, and which varies slightly from place to place. One of the reasons to include detection of the earth's magnetic field is to be able to exclude any interference caused by said field and the changes detected in the magnetic field produced by the magnetic field production means. The magnetic field detection means are used mainly to measure changes in magnetic field produced by movement of the magnetic field producing means, and as will be seen from the detailed description, to calculate an angular rotational position of the magnetic field producing means in order to determine a selected dose for administration via the injectable-drug delivery device. There are naturally other means suitable for detecting angular positions associated with rotational movements, for example, potentiometers, coded wheels and the like, however both of the latter are generally too voluminous for dose control systems such as the one according to the invention, particularly in regard to the fact that the system according to the invention is intended to be removably mounted to the injectable-drug delivery device, e.g. an autoinjector pen, and thus cumbersome and voluminous additional components are generally not preferred.

Other means of detecting magnetic fields to determine a rotational angular position are also known in the art. For example, magneto-resistors are a well known means, some of which are used in the prior art systems. Such magneto-resistors are often designated by their abbreviations, e.g. AMR, GMR, TMR sensors which designate the physical mechanisms by which these sensor components function. Giant magnetoresistance (GMR) is a quantum mechanical magnetoresistance effect observed in thin-film structures composed of alternating ferromagnetic and non-magnetic conductive layers. Anisotropic magnetoresistance, or AMR, is said to exist in materials in which a dependence of electrical resistance on the angle between the direction of electric current and direction of magnetization is observed. Tunnel magnetoresistance (TMR) is a magnetoresistive effect that occurs in a magnetic tunnel junction (MTJ), which is a component consisting of two ferromagnets separated by a thin insulator. Resistors that use these various properties are known per se. Whilst their use is possible in the present dose control system as the means for detecting the magnetic field and changes therein as produced by displacement of the magnetic field producing means and/or the earth's magnetic field, they are limited to dose control systems in which the magnetic field producing means, of corresponding equivalent dimensions and magnetic field strength, is moved away from said GMR, AMR, or TMR sensors by no more than about 25 mm. This

would explain why most of the known prior art solutions have always integrated their sensors and magnetic field producing means within the body of the drug delivery device, in a grouped fashion, over a short distance, or else had to provide four or more aligned magneto-resistive sensors in order to cover the whole available distance of the piston length to cover all possible detectable and usable doses of the drug delivery device, which in many cases can have a maximum path length of up to 40 mm.

In light of the above, the dose control system of the present invention preferably uses magnetometers, for example, at least one magnetometer, and more preferably at least two magnetometers. These magnetometers differ from the GMR, AMR or TMR sensors in that they directly measure magnetic field strength, and changes therein. Magnetometers measure magnetic fields in two main ways : vector magnetometers measure the vector components of a magnetic field and total field magnetometers or scalar magnetometers measure the magnitude of the vector magnetic field. Another type of magnetometer is the absolute magnetometer, which measures the absolute magnitude or vector magnetic field, using an internal calibration or known physical constants of the magnetic sensor. Relative magnetometers measure magnitude or vector magnetic field relative to a fixed but uncalibrated baseline, and are also called variometers, used to measure variations in magnetic field. A suitable and preferred magnetometer for use in the dose control system according to the present invention is an ultra low-power high performance three axis magnetic sensor, available from ST Microelectronics, for example the LIS3MDL. Whilst it is preferred that the magnetometer be able to detect changes in magnetic field over three perpendicular axes, it is also envisaged to be able to measure changes in magnetic field over just two of the three axes of magnetic field produced by the three-dimensional magnetic field production means. A device such as the LIS3MDL can be configured to detect magnetic fields across a full scale up to  $\pm 4$  /  $\pm 8$  /  $\pm 12$  /  $\pm 16$  gauss, however, it could also be useful and advantageous to use magnetometers that are capable of detecting even higher magnetic fields, e.g. 32 gauss. In the present invention, it thus is preferred that the magnetometer be configured to detect magnetic fields of from about 0.5 gauss to about 32 gauss.

As mentioned above, the dose control system of the present invention also comprises displacement detection means configured to measure a relative displacement or relative movement of the drug delivery device. Such displacement detection means could typically use sound, for example, as a way of registering movements in a dose selector shaft, as such dose selector shafts are often constructed so as to make a clicking noise via a toothed cylinder

ratcheting against, for example, the inner wall or a corresponding depression or cavity of said inner wall matching the tooth, which when rotated about the longitudinal axis of the drug delivery device, drives the tooth in and out of said depression or cavity and causes an audible click. The clicking sound thereby facilitates any other visual cues that might be given to the user. Each click generally represents an angle of rotation of the shaft about the longitudinal axis, irrespective of direction of rotation, and corresponds to a selected dose. However, if the dose selector shaft is turned very quickly, or clockwise and counterwise in quick succession, or vice-versa, it becomes almost impossible to know which dose has been selected just by the audible cue of the clicks alone. Thus, the applicants have chosen to measure the movements induced by the vibrations of the dose selector shaft when it is turned and generates one or more clicks, as the vibration provides a relative movement that can be detected. These movements correspond to tiny accelerations, and can be detected and measured appropriately through the use of corresponding accelerometers, which are the preferred means for the displacement detection means of the present invention, as they can be configured to detect accelerational movements along three perpendicular axes, and the time between movements can be measured so as to compare against a predetermined standard set of accelerational movements for said drug delivery devices and which correspond to normal usage of the device at the various stages of its use for administering an injectable product. For example, when the drug delivery device is in a substantially horizontal position, or in either of the substantially vertical positions, i.e. purge or injection, the accelerometer detects a substantially constant signal of low frequency vibrations, which can be used as a base line for the device. Whenever the dose selector shaft, or an end button to prime the injector, or effect injection, is activated, or rotated, the vibrations generated thereby are captured as high frequency spikes compared to the low frequency baseline. These high frequency vibrations can be sampled and analyzed the results of which are then used to determine which operations have been undertaken by a user. Whilst there exist many different types of accelerometer on the market, the applicants have a preference for a low-g three-axis accelerometer, such as those available from ST Microelectronics, under the trade reference LIS331DLH. Additionally, such accelerometers advantageously also comprise means for determining temperature, i.e. they have a built-in temperature sensor, which can assist in determining whether the drug product included in the drug delivery device has been exposed to extremes of temperature likely to make it unsafe to use the drug product. It has been found particularly advantageous if the displacement detection means are located as close as possible to the source of vibrations emitted by the device.

As also indicated in preceding paragraphs, the magnetic field detection means are located along the longitudinal axis of the injectable-drug delivery device. In this way, it is possible to reduce the overall volume of the dose control system by positioning the various detection means along that longitudinal axis. A further advantage is that axial alignment avoids potential distortions of magnetic field, as might be found if the magnetic field detection means were located, for example, perpendicularly or at an angle to said longitudinal axis, and which would either interfere with the measurements, or else require more complex calculations to take into account any such distortion.

The interplay between the displacement detection means, the magnetic field detection means and the magnetic field production means is one of the interesting combinations of features of the present invention.

The dose control system also advantageously comprises an integrated control unit connected to the magnetic field detection means, and to the displacement detection means, for processing information received from both the magnetic field detection means and the displacement detection means. This integrated control unit can be mounted on a printed circuit board, for example, of suitably reduced dimensions, e.g. approximately 45 mm long by 15 mm wide, and 1.5 mm deep. The integrated control unit handles all electrical communication and signalling between the different electronic components of the dose control system. It is also responsible for execution of the dose management system and calculations enabling precise positional locations of the magnetic field production means to be calculated and determined, as well as handling signals from the movement detection means, the autonomous power means, the communication means with a local or remote data processing system, e.g. on a smartphone. It can be programmed remotely, upon first use, or receive information and updates, in a similar way to other electronic devices today containing integrated control units. Such integrated control units are known per se, and often integrate a central processing unit, a real time clock, one or more memory storage systems, and optionally communications systems or subsystems, along with other desired components.

The dose control system of the present invention marks a clear break with the past solutions, by providing a dose control system, that is not only removably mounted on the body of the drug delivery device, but is also capable of accurately providing detection of changes in angular position due to subtle changes in magnetic field, and thereby calculating the corresponding selected dose, without having to place all of the components within the body of the drug delivery device. In fact, the dose control system of the present invention has enabled

the applicants to provide a removably mountable system, that can be used with a variety of different drug delivery devices currently on the market, in particular, but not exclusively, the insulin autoinjector pens that are currently distributed for patient self-medication.

## BRIEF DESCRIPTION OF THE FIGURES

The invention will be further described in relation to the accompanying figures, provided for illustrative and non-limiting purposes of exemplary manifestations of the embodiments of the present invention, in which:

- Figure 1 is a schematic view of an example of a dose control system according to the present invention;
- Figure 2 is schematic flow chart of the functioning of part of the system;
- Figure 3 is a cross-sectional schematic representation of a dose control system according to the present invention, mounted onto an injectable-drug delivery device, in this case, an insulin autoinjector pen;
- Figure 4 is a close up schematic cross-sectional representation of a removably mountable dose control system according to the present invention, in its unmounted or “free” state.

## DETAILED DESCRIPTION

Turning now to Figure 1, a schematic diagram of the components of a dose control system (1) according to the present invention is displayed. Such a dose control system comprises for example, an integrated control unit (2), for example, mounted on a printed circuit board, or equivalent on which various components are mounted and in connection with each other. The integrated control unit (2) could also be comprised of circuits engraved or etched in silicon or the like, as is known per se. In fact, virtually the whole dose control system could be engraved into a single, or multiple, interconnected blocks of silicon or other similar semi-conductor material as generally known in the art if so desired. The integrated control unit (2) comprises a central processing unit (CPU, 3), which is responsible for processing and managing signals and communication between the various components of the system, and also for calculations, and execution of program code stored within the system, or operable remotely on said system. The integrated control unit (2) additionally comprises a real time clock (RTC, 4), for keeping

and measuring time within the dose control system. The real time clock (RTC, 4) can also be integrated into the central processing unit (CPU, 3), for example, using frequency measurements whilst the central processing unit (CPU, 3) is powered with energy, in order to calculate time and time differences for various events within the system. The dose control system is also equipped with a communications subsystem (COM, 5), for example a low power consuming bluetooth radio device, the communications subsystem allowing for the dose control system to communicate with a local or remote data processing system (not shown), e.g. a smartphone and corresponding smartphone application, used to provide information and feedback to the user on usage of the dose control system. Additionally, the system also has some form of memory storage (MEM, 6), for storing information within the system, whether transiently or permanently, such information coming from a variety of sources, including the values or signals measured or determined from other endpoints of the system, values calculated or stored by the central processing unit (CPU, 3), values or data received from the remote or local data processing system, such as the smartphone, factory settings for calibration of the system, a unique identifier means or data identifying the device uniquely, and the like. Such memory storage systems (MEM, 6) are known per se to the skilled person.

The integrated control unit (2), and by extension, the central processing unit (CPU, 3), is also in communication with at least one accelerometer (ACC, 7) and at least one magnetometer (MGR, 8). The accelerometer (ACC, 7) is responsible for detecting and/or measuring changes in relative movement due to acceleration of the drug delivery device on which the dose control system is mounted, be it from a horizontal to vertical position as held by the user, or any position in between, with regard to a set of pre-determined and pre-programmed reference positions. The accelerometer (ACC, 7) is also responsible for detecting and/or measuring changes in relative movement due to acceleration of the drug delivery device when a user sets a dosage via a dose selector shaft, which causes a vibration of the drug delivery device, i.e. a relative movement of acceleration, that is detectable by the accelerometer (ACC, 7). The strength and frequency of the relative movements of acceleration, which are communicated from the accelerometer (ACC, 7) to the central processing unit (CPU, 3) are used to determine the type of operation that the user has effected. Such relative movements of acceleration can include vibrations caused by clicks produced by the drug delivery device, e.g. in the majority of autoinjector drug delivery devices, e.g. pens, for self-injection of various drugs, e.g. insulin, ATP, and the like, these clicks provide an audible cue signal for the user to indicate

various operations undertaken by the latter, but the clicks also produce vibrations within the drug delivery device that can be suitably picked up by an accelerometer.

The magnetometer (MGR, 8) is also connected to the central processing unit (CPU, 3). This component is responsible for detecting changes in magnetic field, as produced by movement of the magnet (MAG, 9) which is in a movable spaced relationship with the magnetometer (MGR, 8). The magnetometer is capable of detecting changes of magnetic field along multiple axes, for example one, two, three or more axes, although detection of changes in magnetic field along two or three axes are preferred. Usually, these axes are perpendicular to one another, so as to provide a three-dimensional magnetic field detection zone. The at least one, and preferably two, magnetometers are located so as to be able to detect corresponding changes in magnetic field as the magnet (MAG, 8) is displaced. As the drug delivery device on which the dose control system is mounted has a longitudinal axis, it is preferable to also locate the at least one magnetometer (MGR, 7) along said longitudinal axis. In a preferred embodiment, the system includes two magnetometers and these are located in axial alignment along the longitudinal axis of the drug delivery device when the dose control system is mounted on said device. This allows the dose control system to remain compact in size and dimensions, and thereby not negatively influence or interfere with normal, habitual manipulation of the drug delivery device by the user. The magnetometer is also suitably configured to detect the earth's magnetic field, and any changes therein that might occur when the user travels with the drug delivery device, as the earth's magnetic field, and changes therein can influence the measurements made by the magnetometer (MGR, 7) in regard to the magnetic field producing means of the dose control system.

The magnetic field producing means in the present exemplary device include a magnet (MAG, 9). In one particularly preferred embodiment, the magnet produces a three dimensional magnetic field along three perpendicularly positioned axes (x, y, z). As mentioned above, the magnetometer (MGR, 7) detects changes in magnetic field produced by the magnet (MAG, 9), when the latter is displaced proximally, and away from, or distally and towards, a proximal extremity of the drug delivery device. This detection of magnetic field changes occurs without any form of electrical or electronic or physical contact between the magnetometer(s) (MGR, 7) and the magnet (MAG, 9), leading to the designation of the dose control system as a contactless system. The magnet preferably has a substantially annular shape, with a hole in the middle, and can be made of any suitable magnetic or magnetizable material, details of which are given elsewhere in the present specification. The magnet (MAG,

9) can thus be mounted on a dose selector shaft of the drug delivery device, which is in longitudinal axial alignment with both the longitudinal axis of the drug delivered device and the magnetometer(s). The dose selector shaft is generally rod shaped, such that the substantially annular magnet can be removably slid onto the shaft, and produce a three-dimensional magnetic field around the proximal extremity of the drug delivery device. The magnet is removably mounted on the dose selector shaft in such a way that it can impart rotational movement to said shaft when turned by a user. Rotation can occur in both clockwise and counter-clockwise directions. The magnet has two opposing poles, each substantially constituting a half, or hemi-spherical part of the annular magnet. As the magnet rotates, the opposing poles also rotate about the longitudinal axis of the device. A first reference point of known magnetic field strength along one, two or three axes, is detected by the magnetometer(s) and this information is stored in the dose control system, for example in memory (MEM, 6), via the central processing unit (CPU, 3). Generally, this first position will correspond to a position of the magnet (MAG, 9) in which it is closest to the proximal extremity of the drug delivery device, and beyond which further rotation of the dose selector shaft in a given direction is impossible. When the user rotates the magnet (MAG, 9), in an allowed direction of rotation, and correspondingly indexed rotational movement of the dose selector shaft, the magnet and proximal extremity of the dose selector shaft move longitudinally in a proximal direction away from the proximal extremity of the body of the drug delivery device, but along the longitudinal axis of the device in general. As the magnet (MAG, 9) rotates around said longitudinal axis, and translates there along, changes in magnetic field and polarity are detected by the suitably positioned magnetometer(s) (MGR, 8). The variations in magnetic field can be resolved into mathematical components comprising vectors and moduli by the central processing unit (CPU, 3), and therefrom an angular position of rotation calculated, allowing for extremely precise determination of the angular position and distance of the magnet with respect to the magnetometer(s) MGR, 8). These positions are correlated to a dose selected or selectable by the user in a lookup table which is preferably stored within the system, or alternatively stored within a remote data processing unit, such as a smartphone, wherein the maximum and minimum distances of allowed travel and rotation of the magnet (MAG, 9) along the longitudinal axis correspond to the maximum and minimum dosages allowed by the drug delivery device. In this way, the dose control system is able to present to the user an exact representation of the dose selected by the user at any given rotational and translational movement point of the magnet (MAG, 9), without interfering or changing the usual modus operandi of the drug delivery device. In an

exemplary dose control system of the invention, the magnetometer(s) are configured to be able to detect magnetic fields from between  $\pm 4$  gauss to  $\pm 16$  gauss, with a sensitivity, or resolution, of between about 6842 LSB/gauss at  $\pm 4$  gauss to about 1711 LSB/gauss at  $\pm 16$  gauss. This means that the dose control system preferably has a resolution that is able to detect changes in magnetic field corresponding to an angular rotation of the magnet and dose selector shaft of  $0.9^\circ$  about the longitudinal axis, but as mentioned above, the resolution and sensitivity of the various components can be configured to correspond to any drug delivery device that functions in the same way via a rotatable dose selector shaft.

Also represented in Figure 1 are a power supply (POW, 10), which is generally a portable, autonomous power supply, for example, one or more batteries, or rechargeable power elements, capable of supplying sufficient electrical power to the entire system, even when for example, the device is not being directly manipulated. The integrated control unit (2) can additionally comprise a power management unit, that regulates power supply voltage to the system, including its various components, in order to maximise the longevity of said autonomous power supply. The power supply can also communicate with a user-activated wake-up button (WAK, 11) which allows the dose control system to be woken up by the user from a hibernating or sleeping state.

The dose control system can also further comprise a light emitting signal (LIG, 12), for example, a LED, which indicates a status of the device according to detected events or conditions and managed by the central processing unit (CPU, 3), e.g. green, red, blue and white colour emission, each colour corresponding to a certain state or condition of the dose control system.

In yet a further embodiment, the dose control system can also comprise an alarm (ALA, 13) system, in communication with the central processing unit (CPU, 3), which can be configured to emit an audible alarm, say, in the case of malfunction of the system, or in the case of a failed injection, or for any other suitable condition or event detected within the system.

Figure 2 is a schematic block diagram representation of the functioning of a dose control system according to the invention. In a first step, wheel click detection (14) of the rotating dose selector shaft is effected by the accelerometer, as the click generates vibrations which are picked up by the accelerometer (ACC, 7). The magnetic field values detected (15) by the magnetometer(s) (MGR, 8) of the magnet (MAG, 9) which rotates at the same time as the dose selector shaft are then read into the central processing unit (CPU, 3). Next, the angle and

modulus of the magnetic field are calculated (16) by the central processing unit (CPU, 3). These values are correlated with, or compared to (17) a predetermined set of values that has been preprogrammed into the dose control system. Finally, a determination (18) of the selected dose is made. These steps are repeated as necessary, each time the user causes the dose selector shaft to rotate about the longitudinal axis. Once the user has decided which dose it wishes to inject itself with, a click caused by the user pressing a proximally located injector end button, which causes a vibration and corresponding movement of acceleration within the drug delivery device, is registered by the accelerometer. The frequency, or interval between each end button click is used to determine whether an injector button click is compared to a known list of pre-determined movements of acceleration to determine whether the end button click was intentional, or else the result of accidental activation of the end button or movement in the drug delivery device. If the movement of acceleration and frequency thereof do correspond to a situation in which the dose is recognized as having been deliberately selected, ready for injection, this dose is registered within the system, e.g. within memory, and communicated via the communication means to the data processing unit, for example, a smartphone application, along with the time at which said event occurred. In this way, the smartphone application is able to process that information and provide it to the user in the form of tracking or observance information.

Figure 3 is a schematic cross-sectional representation of a dose control system mounted on an injectable-drug delivery device, indicated generally by the reference numeral 20. The injectable-drug delivery device (20) generally comprises a substantially elongate drug delivery body (21), having a longitudinal axis (25), at least one injectable drug held by the body (not shown), usually within a cartridge, the body (21) having a distal extremity (23) and a proximal extremity (22), and an outer peripheral surface (24). In Figure 3, at the distal extremity (23), a cap (26), similar to a pen cap, is provided to cover the otherwise exposed needle and prevent the user from accidentally stabbing or otherwise injuring themselves. The drug delivery device further comprises, at the proximal extremity (22), a dose selector shaft (27), which is connected to a dose selector wheel (28), rotatable about the longitudinal axis, and an end button which can be pressed by the user to arm the device, thereby validating a selected dose, and effect drug injection via usual, known methods and means. This type of drug delivery device is similar to majority of drug delivery devices known to the skilled person.

The dose control system is indicated in Figure 3 by the general reference numeral 30. As is

apparent from Figure 3, the dose control system (30) is located substantially at a proximal extremity of the drug delivery device (20), and is positioned on and around the outer peripheral surface (24) of the body of said device. In this particular example, the central processing unit (CPU, 3), real time clock (RTC, 4), storage memory (MEM, 6) and communications subsystem or communication means (COM, 5) are located on a printed circuit board to form the integrated control unit (2) which is encased within a polymer resin block (31). The dose control system has an autonomous power supply (POW, 10) in this example and Figures 3 and 4 illustrated as two batteries (32, 33), for example lithium ion batteries. The dose control system further comprises magnetic field producing means (MAG, 9), illustrated in Figure 3 as a substantially annular shaped object which is located at the proximal extremity (22) of the device, and in a proximally spaced relationship to said extremity (22), whereby the magnet (MAG, 9) is removably mounted on the dose selector wheel (28), which in turn is connected to the dose selector shaft. As the wheel (28), shaft (27) and magnet (MAG, 9) can be caused to rotate around the longitudinal axis (25) of the drug delivery device (20), the magnet (MAG, 9) will be displaced both rotationally around said axis thereby also effecting a translational movement away from, in a proximal direction, or alternatively, towards, i.e. in a distal direction, the proximal extremity of the body (21) of the drug delivery device (20). The maximum distance of linear travel of the wheel (28), shaft (27) and magnet (MAG, 9), will generally substantially correspond to the maximum allowable dose that can be injected, and also therefore correspond to the maximum distance of travel of a piston that is usually provided to eject the drug from the cartridge in which it is held. As an example, the position nearest to the proximal extremity of the body of the drug delivery device will correspond to either no dose, or the minimum dosage. The wheel (28), shaft (27) and magnet (MAG, 9) will be blocked from rotating in a direction that would be likely to bring the latter even closer to the proximal extremity (22) of the body (21). In the opposite direction, however, i.e. in the proximal direction, the wheel (28), shaft and magnet will be able to be caused to rotate, e.g. via a user turning the magnet (MAG, 9) and wheel (28) with their fingers as many times as is allowed by the configuration of the system, and corresponding to the maximum dosage that can be injected. As the magnet, and wheel are turned, the shaft also rotates, and generates an audible clicking sound. The audible clicks correspond to a movement of acceleration transmitted through the body of the device and detected by the accelerometer (7). The rotation and longitudinal displacement of travel of the magnet (MAG, 9) causes changes in the produced magnetic field which are detected by the magnetometers (34, 35). The values detected by the magnetometers (34, 35) are

communicated to the central processing unit (CPU, 3), and used to calculate angular position of the magnet (MAG, 9) and wheel (28) on the dose selector shaft (27) and thereby determine the dose which has been selected by the user. Priming of the injector system, via a push from the user on the end button (29), which also raises an audible click, and a corresponding linear movement of acceleration along the longitudinal axis of the device (20), is registered by the accelerometer (7). The central processing unit (CPU, 3) calculates the frequency and number of clicks produced and compares them to stored values in a lookup table to determine whether or not the device is effectively primed for injection, and if it is determined by the central processing unit that such is the case, the value of the calculated dose obtained from the changes in magnetic field is stored in memory (MEM, 6) and validated as the dose selected for injection. This value is then communicated via the communication means (COM, 5) to the smartphone application.

The magnetic field detectors can be configured to function in various ways. For example, in a serial configuration of magnetometers, i.e. when the magnetometers are aligned axially along the longitudinal axis, in a spaced apart relationship, and when the magnet (MAG, 9) is closest to the proximal extremity of the body (21) of the drug delivery device, the force of the magnetic field produced by the magnet can exceed the upper limit of the magnetometer (8a) closest to the magnet. In such a case, the magnetometer (8a) is considered to be "saturated". At this point, it is unnecessary to factor in any values detected by the second magnetometer (8b), since saturation of the first, proximal magnetometer (8a) allows for complete resolution of the angular moment and modulus when the magnet is rotated about the longitudinal axis. If the dose selector shaft is designed to also effect lateral displacement along said longitudinal axis, proximally, and away from said proximal extremity, as the magnet also moves away proximally, so does the saturation of the first proximal magnetometer (8a) drop. Once a predetermined level of magnetic field has been reached, the system is configured to activate the second, more distal magnetometer (8b), so that both magnetometers (8a, 8b) can be used to effect fine detection of smaller and smaller changes in magnetic field and angular moment, including taking into account any effects due to the earth's own magnetic field which, at the earth's surface is generally between 0.25 and 0.65 gauss. In a similar and reverse manner, when the dose selector shaft, and magnet, move distally back towards the proximal extremity of the body of the device, the second, more distal magnetometer (8b) can be automatically switched off when a predetermined higher level of magnetic field is detected. In an alternative, parallel, configuration, on the other hand, both magnetometers (8a, 8b), whilst still

aligned along the longitudinal axis of the drug deliver device, are both operational throughout all of the displacements of the magnet, and all changes in magnetic field are detected by both magnetometers (8a, 8b).

Figure 4 is a schematic cross-sectional representation of a housing suitable for including the dose control system of the present invention and illustrating one of several ways in which the dose control system can be mounted on an injectable-drug delivery device such as those currently known. Reference numerals remain the same between Figures 3 and 4 for like elements of the dose control system. The housing (35a, 35b) is designed to encase and enclose the drug delivery device (20), around and along its longitudinal axis (25) and sits removably on a peripheral outer surface (24) of said device (20). The housing is designed to snap or push fit onto the device (20) and preferably comprises at least two mating components, which engage with each other and encase the device along its body (21), along the longitudinal axis (25), at a proximal extremity (22) thereof. The housing (35a, 35b) further comprises grip facilitating means, for example a zone (36a, 36b) of compressible elastomer, located on an inner wall of the housing, and which facilitates and increases the grip of the housing containing the dose system on the outer peripheral surface (24) of the body (21) of the drug delivery device (20) to provide a snug fit that will prevent the housing (35a, 35b) from moving relative to the body of the drug delivery device until such time as the housing is to be removed, for example, if the drug delivery device malfunctions, or the cartridge is empty or quite simply if it is desired to switch the dose control system to another drug delivery device (20). The housing is designed preferably to be snap fit, enabling it to be removed according to a predetermined set of steps, wherein each part of the housing (35a, 35b) is removed according to a sequence, without destroying or damaging the dose control system (30) contained therein, or the drug delivery device (20). The zone of compressible elastomer (36a, 36b) can further comprise compression facilitating ridges or dips (37a, 37b), i.e. added or removed elastomeric material in spaced apart arrangement along the length and breadth of the zone (36a, 36b) so as to increase or decrease grip of the housing (35a, 35b) on the outer peripheral surface (24) of the device (20). The housing (35a, 35b) additionally provides a window (39) allowing a user to see an analog or digital representation of the selected dose, which is generally located and displayed on the outer peripheral surface (24) of the body (21) of the drug delivery device (20). The dose control system containing the magnetic field producing means (MAG, 9) is housed in a separate housing (38) that is located, and fits snugly with, the wheel (28). This magnet housing (38) is designed in a similar way to the

housing (35a, 35b) of the other components of the dose control system to be able to be removably snap or push fit onto the wheel (28) of the dose selector shaft (27) and can also advantageously comprise grip facilitating means, for example a zone of elastomeric material enabling the magnet housing (38) to surround and encase the wheel (28).

What is claimed is:

1. Dose control system adapted for an injectable drug delivery device, the drug delivery device comprising:

- 5 a substantially elongate drug delivery body;  
at least one injectable drug held by the body;  
the body having a distal and proximal extremity, and a longitudinal axis, and  
a dose selector shaft,

wherein the dose control system comprises:

- 10 three-dimensional magnetic field producing means for producing a magnetic field along three axes (x,y,z);

magnetic field detection means configured to detect changes in at least the magnetic field produced by the three-dimensional magnetic field producing means, the magnetic field detection means being located along said longitudinal axis; and;

- 15 displacement detection means configured to measure a relative displacement or relative movement of the drug delivery device, and

an integrated control unit, wherein the integrated control unit is connected to the magnetic field detection means, and to the displacement detection means, for processing information received from both the magnetic field detection means and the displacement detection means;

- 20 wherein:

the three-dimensional magnetic field producing means is configured to effect a rotating coaxial displacement around, and along, the longitudinal axis of the drug delivery system;

the three-dimensional magnetic field producing means is an annular shaped object mounted around the dose selector shaft at a proximal extremity thereof; and

- 25 the magnetic field detection means and the displacement detection means are removably mounted on the body of the drug delivery device.

2. Dose control system according to claim 1, wherein the dose control system is removably mounted to an exterior peripheral surface of said injectable drug delivery device.

3. Dose control system according to claim 2, wherein said dose selector shaft is configured to operate a displacement of the three-dimensional magnetic field producing means relative to the drug delivery device, whereby said three-dimensional magnetic field producing means is configured to move both in a proximal direction away from, and in a distal direction towards, the body of the drug delivery device.
4. Dose control system according to any one of claims 1 to 3, wherein the magnetic field detection means is further configured to detect the earth's magnetic field (EMF).
5. Dose control system according to any one of claims 1 to 4, wherein the magnetic field detection means comprises at least one magnetometer.
6. Dose control system according to any one of claims 1 to 5, wherein the magnetic field detection means comprises at least two magnetometers.
7. Dose control system according to any one of claims 1 to 6, wherein the magnetic field detection means comprises at least a first and second magnetometers, wherein the first magnetometer and the second magnetometer are configured to operate in parallel, both magnetometers simultaneously detecting any changes in magnetic field, as the three-dimensional magnetic field producing means is displaced proximally away from or distally towards them.
8. Dose control system according to any one of claims 1 to 6, wherein the magnetic field detection means comprises at least a first and second magnetometers, wherein the first magnetometer and the second magnetometer are configured to operate in series, whereby the first magnetometer detects changes in magnetic field until a predetermined value of magnetic field is detected, and then the second magnetometer is activated to detect changes in magnetic field beyond said predetermined value, as the three-dimensional magnetic field producing means is displaced proximally away from or distally towards them.
9. Dose control system according to any one of claims 1 to 8, wherein the displacement detection means comprise at least one accelerometer configured to detect:
- the relative movement of acceleration caused by a vibration of the dose selector shaft; and/or
  - a positional movement of the drug delivery device between an injection position and a purge position.
10. Dose control system according to any one of claims 1 to 9, wherein the dose control system further comprises communication means configured to enable communication of information from the integrated control unit with a remote and/or local data processing system.
11. Dose control system according to claim 10, wherein the remote and/or local data processing system comprises a smartphone application.

12. Dose control system according to claim 10 or 11, wherein the dose control system further comprises a unique identifier that is communicated to the remote and/or local data processing system.
13. Dose control system according to any one of claims 1 to 9, wherein the dose control system further comprises autonomous power supply means.
- 5 14. Dose control system according to any one of claims 10 to 12, wherein the dose control system further comprises autonomous power supply means.
15. Dose control system according to claim 14, wherein said magnetic field detection means, said displacement detection means, said integrated control unit, said autonomous power supply means, and said communication means are all located within a first removably mountable housing configured to
- 10 removably be mounted on, and encase the body of said injectable-drug delivery device, and said three-dimensional magnetic field producing means is located within a second housing configured to removably be mounted on, and surround the dose selector shaft of said body of said injectable-drug delivery device.
16. Dose control system according to any one of claims 1 to 15, wherein the dose control system further comprises temperature detection means.
- 15 17. Dose control system according to any one of claims 1 to 16, wherein the dose control system further comprises time determination means.
18. Method for improving observance of treatment in an injectable drug administration regime, said method comprising:
- providing a dose control system according to any one of claims 1 to 17 removably mounted to a
- 20 peripheral exterior surface of an injectable drug delivery device comprising a substantially elongate drug delivery body, at least one injectable drug held by the body, the body having a distal and proximal extremity;
- determining a dose set by the user via manipulation of the dose control system; and
  - determining an operational status of the drug delivery device;
- 25 - relaying information obtained from said dose determination or said operational status determination to a remote and/or local data processing system.
19. Method for improving observance of treatment in an injectable drug administration regime according to claim 18, said method further comprising:
- validating an actual injected dose of injectable drug.
- 30 20. Method for improving observance of treatment in an injectable drug administration regime according to claim 18 or claim 19, wherein determination of a user-set dose is effected by:

- rotating a three-dimensional magnetic field producing means, removably mounted on a dose selector shaft, around a longitudinal axis of said body of the drug delivery device;

- detecting changes in magnetic field produced in at least two orthogonal dimensions, via magnetic field detection means removably mounted on the body of the drug delivery device;

5           - correlating, via an integrated control unit, the changes in magnetic field detected by the magnetic field detection means, with an angular position of the rotated three-dimensional magnetic field producing means;

- correlating said angular position to a corresponding dose.

21.       The method according to claim 20, wherein the step of detecting changes in magnetic field is  
10       produced in three orthogonal dimensions (x,y,z).

22.       Method for improving observance of treatment in an injectable drug administration regime according to any one of claims 18 to 21, wherein a determination of an operational status of the drug delivery device comprises one or more of the following:

15           - detecting a positional movement of the drug delivery device via displacement detection means removably mounted on the body of the drug delivery device to determine whether the device is in a purge position, or an injection position;

- detecting a temperature of the drug held by the body of the drug delivery device via temperature detection means and determining whether said temperature is within acceptable operating limits for an administration of the drug;

20           - detecting a level of autonomous power supply; and

- detecting whether the dose control system is in a hibernated or awake state.

23.       Method for improving observance of treatment in an injectable drug administration regime according to any one of claims 18 to 22, wherein validation of an actual injected dose of injectable drug is effected by:

25           - detecting a validation of a dose setting via displacement detection means removably mounted on the body of the drug delivery device, said validation being created by a clicking action of the user on a distal extremity of the dose selector shaft;

- measuring elapsed time between said clicking action of the user and actual injection of the drug;

30           - correlating the elapsed time between said clicking action of the user and the time at which actual injection occurs with an acceptable set of stored values to validate the selected dosage as the actual injected dosage of injectable drug.

24. Method for improving observance of treatment in an injectable drug administration regime according to any one of claims 18 to 23, wherein determination of a user-set dose is effected by:

- rotating the three-dimensional magnetic field producing means, removably mounted on a dose selector shaft, around a longitudinal axis of said body of the drug delivery device, wherein each rotatory  
5 movement generates a series of one or more audible clicks, each rotational click also producing a vibration and corresponding relative displacement movement in the device;

- the relative displacement movements in the device produced by each rotational click being detected by the displacement detection means.

25. Method for improving observance of treatment in an injectable drug administration regime  
10 according to claim 24, wherein each click corresponds to a rotational displacement of the magnetic field producing means around the longitudinal axis of the device.

26. Method for improving observance of treatment in an injectable drug administration regime according to any one of claims 18 to 25, wherein the displacement detection means have a maximum resolution comprised between 1 Hz and 2 KHz.

15 27. Method for improving observance of treatment in an injectable drug administration regime according to any one of claims 18 to 26, wherein the displacement detection means are configured to detect accelerational displacements of from about 0.5G to about 16G.

28. Method for improving observance of treatment in an injectable drug administration regime  
20 detect changes in magnetic field from about 0.5 gauss to about 32 gauss.

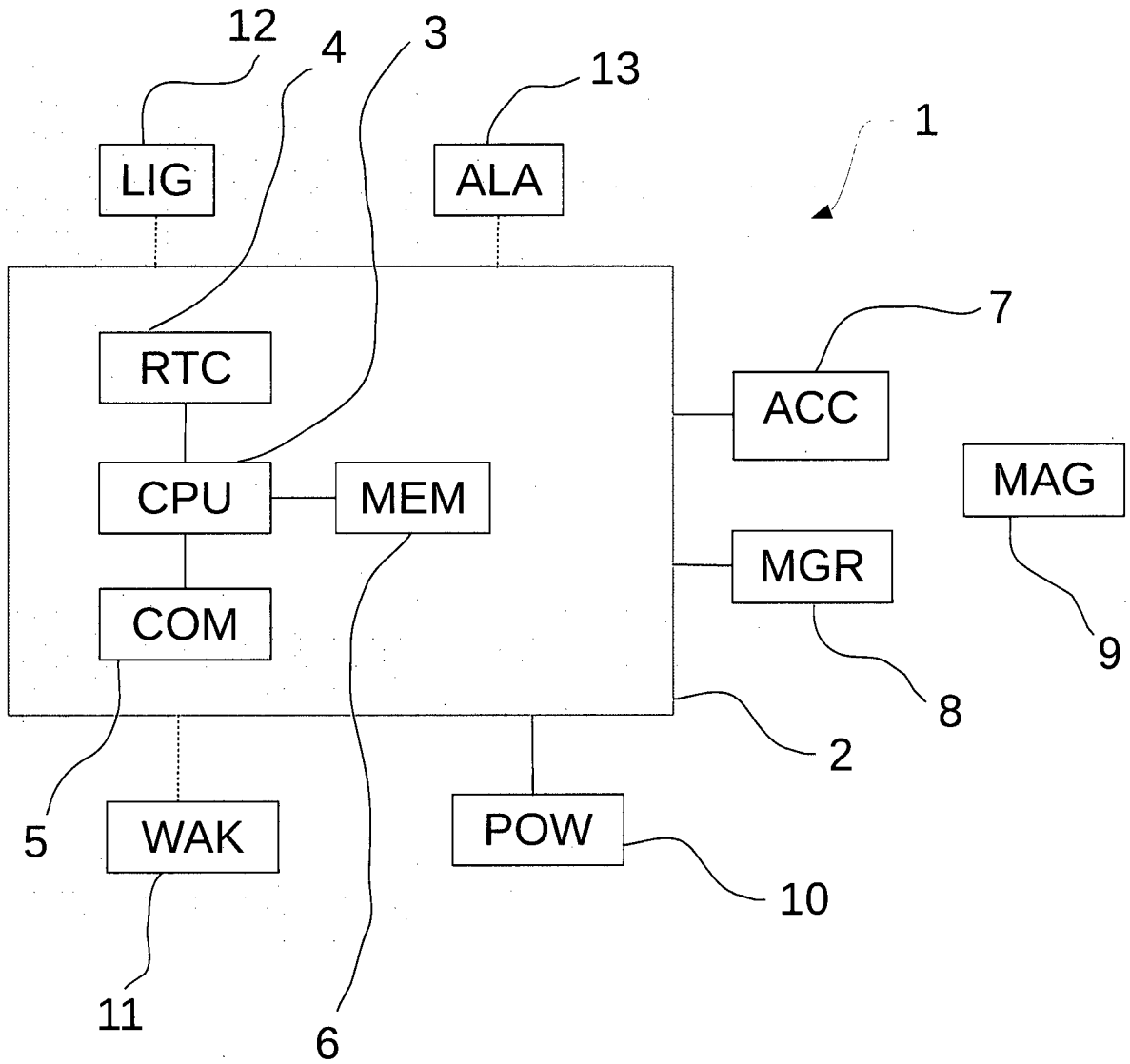

Fig. 1

2 / 4

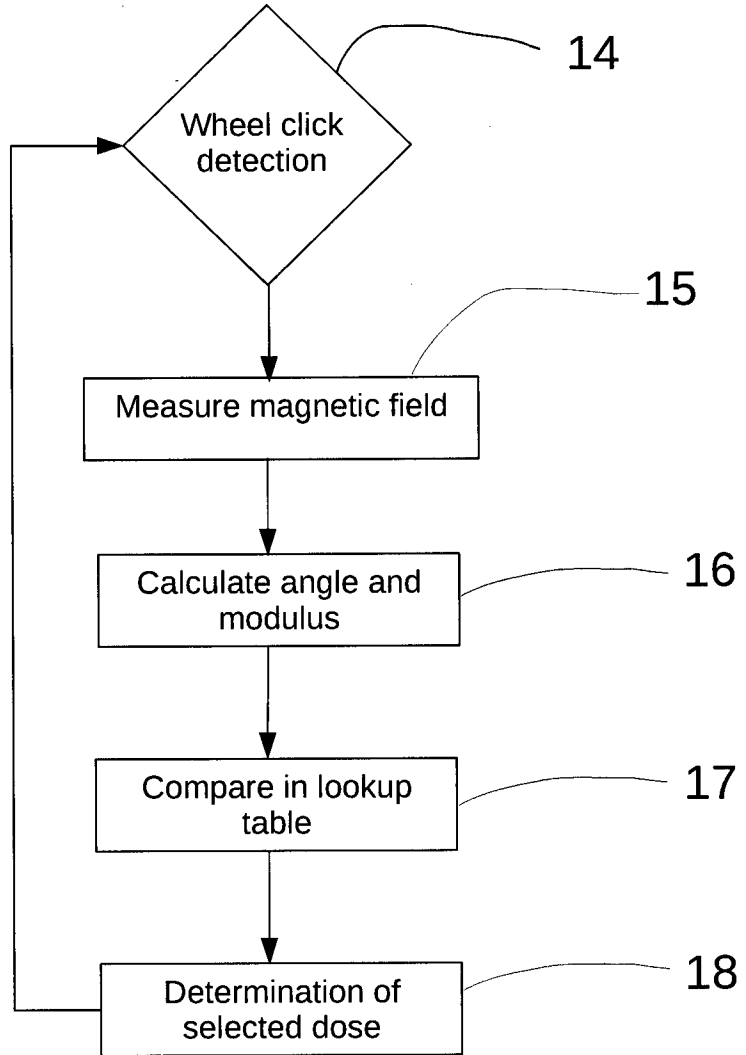

Fig. 2

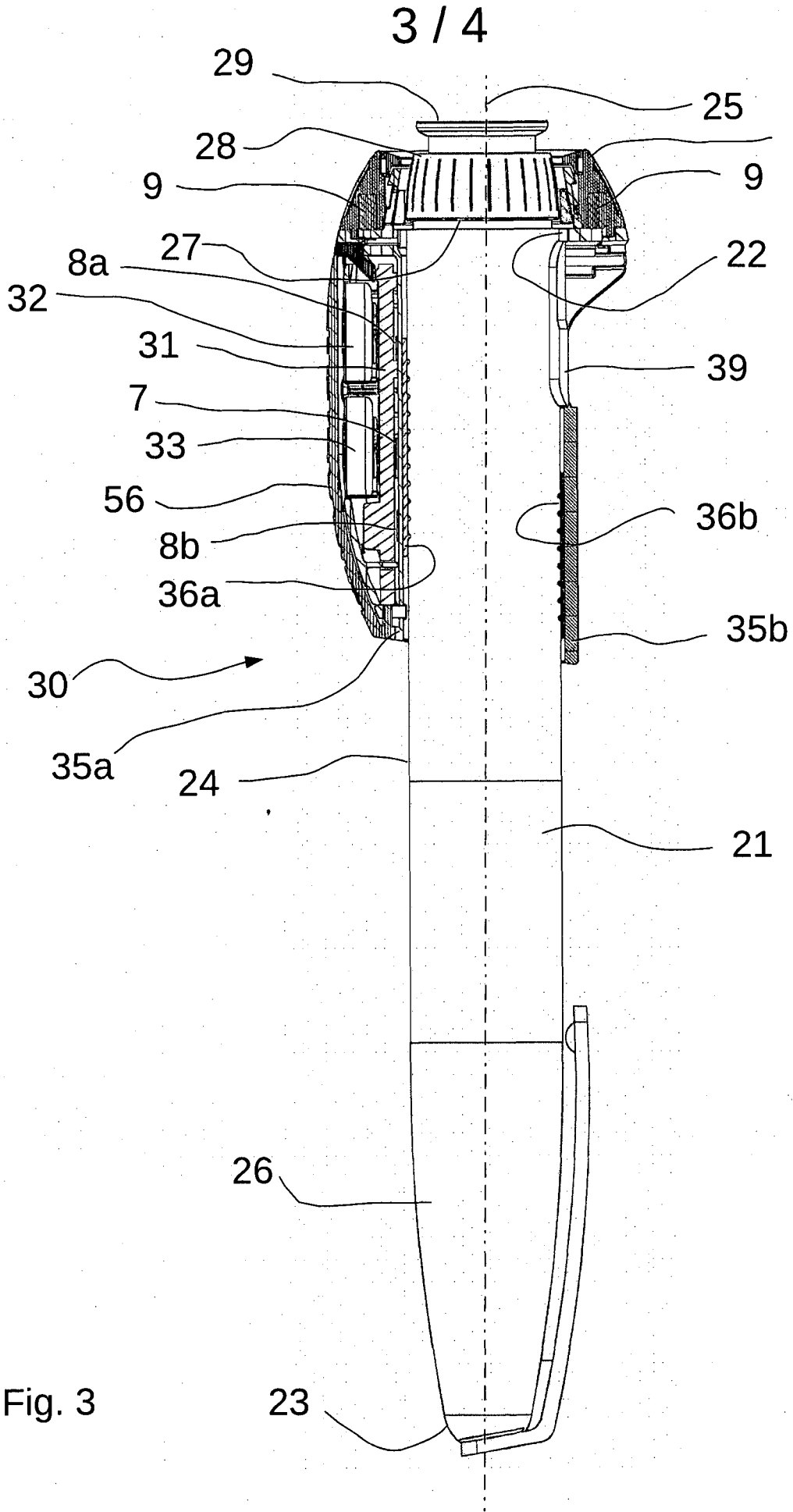

Fig. 3

4 / 4

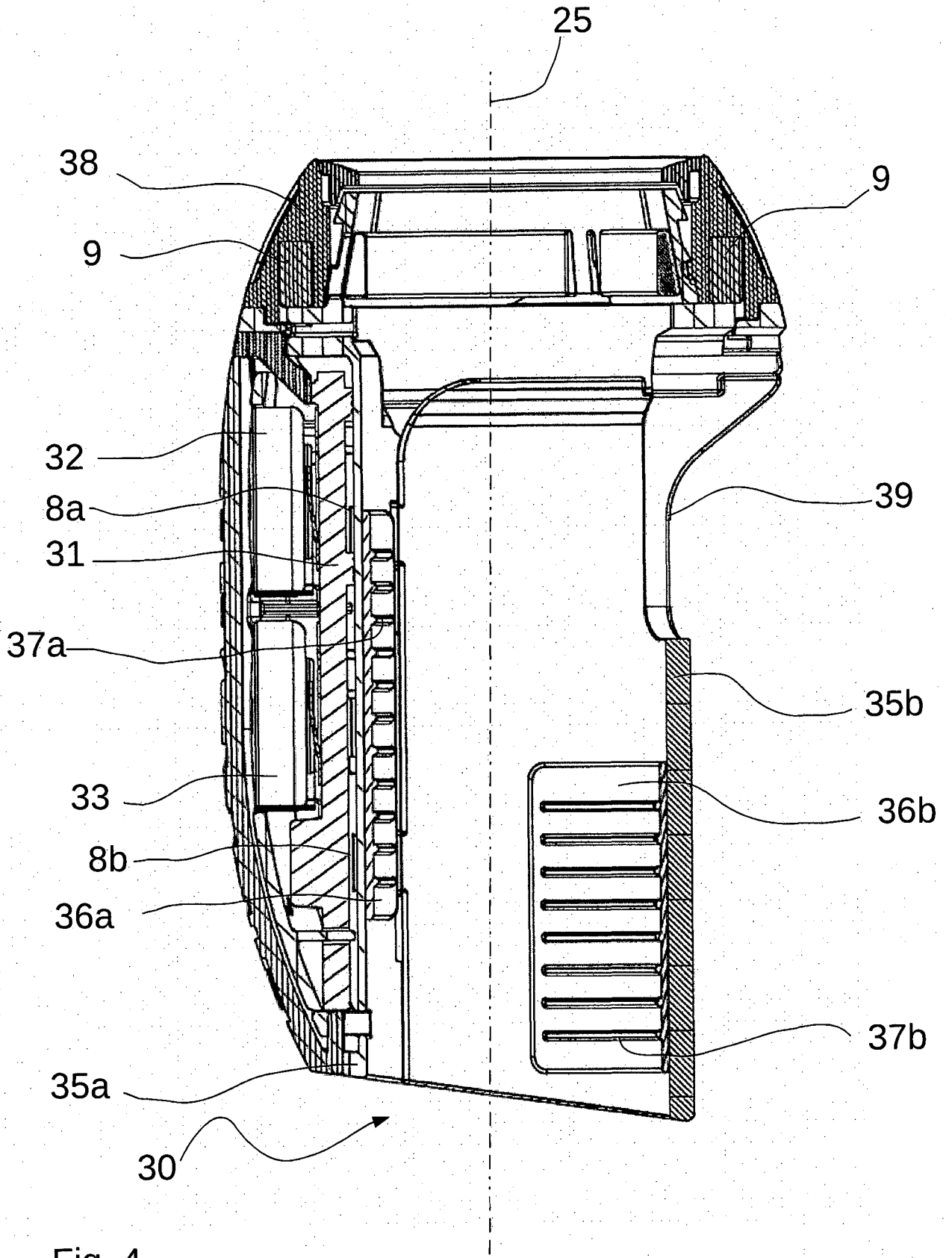

Fig. 4

