



(51) International Patent Classification:

A61B 17/70 (2006.01) H01Q 1/22 (2006.01)  
A61F 2/46 (2006.01) H01Q 1/38 (2006.01)  
A61B 90/00 (2016.01)

(21) International Application Number:

PCT/US2019/042511

(22) International Filing Date:

19 July 2019 (19.07.2019)

(25) Filing Language:

English

(26) Publication Language:

English

(30) Priority Data:

16/039,592 19 July 2018 (19.07.2018) US  
16/395,212 25 April 2019 (25.04.2019) US

(71) Applicant: **WARSAW ORTHOPEDIC, INC.** [US/US];  
2500 Silveus Crossing, Warsaw, Indiana 46582 (US).

(72) Inventors: **BENSON, Nicholas**; 1146 Talamore Cove,  
Collierville, Tennessee 38017 (US). **REZACH, William  
A.**; 2928 Terry Lane South Road, Covington, Tennessee  
38019 (US). **KURIAN, Arjun S.**; 610 S Front Street, Apt  
204, Memphis, Tennessee 38103 (US). **METCALF, New-  
ton H., Jr.**; 2951 Tishomingo Ln, Memphis, Tennessee  
38111 (US).

(74) Agent: **WOLFE, Thomas et al.**; Medtronic, Inc., 1800  
Pyramid Place, Memphis, Tennessee 38132 (US).

(81) Designated States (unless otherwise indicated, for every

kind of national protection available): AE, AG, AL, AM,  
AO, AT, AU, AZ, BA, BB, BG, BH, BN, BR, BW, BY, BZ,  
CA, CH, CL, CN, CO, CR, CU, CZ, DE, DJ, DK, DM, DO,  
DZ, EC, EE, EG, ES, FI, GB, GD, GE, GH, GM, GT, HN,  
HR, HU, ID, IL, IN, IR, IS, JO, JP, KE, KG, KH, KN, KP,  
KR, KW, KZ, LA, LC, LK, LR, LS, LU, LY, MA, MD, ME,  
MG, MK, MN, MW, MX, MY, MZ, NA, NG, NI, NO, NZ,  
OM, PA, PE, PG, PH, PL, PT, QA, RO, RS, RU, RW, SA,  
SC, SD, SE, SG, SK, SL, SM, ST, SV, SY, TH, TJ, TM, TN,  
TR, TT, TZ, UA, UG, US, UZ, VC, VN, ZA, ZM, ZW.

(84) Designated States (unless otherwise indicated, for every

kind of regional protection available): ARIPO (BW, GH,  
GM, KE, LR, LS, MW, MZ, NA, RW, SD, SL, ST, SZ, TZ,  
UG, ZM, ZW), Eurasian (AM, AZ, BY, KG, KZ, RU, TJ,  
TM), European (AL, AT, BE, BG, CH, CY, CZ, DE, DK,  
EE, ES, FI, FR, GB, GR, HR, HU, IE, IS, IT, LT, LU, LV,  
MC, MK, MT, NL, NO, PL, PT, RO, RS, SE, SI, SK, SM,  
TR), OAPI (BF, BJ, CF, CG, CI, CM, GA, GN, GQ, GW,  
KM, ML, MR, NE, SN, TD, TG).

Published:

— with international search report (Art. 21(3))

(54) Title: BREAK-OFF SET SCREW

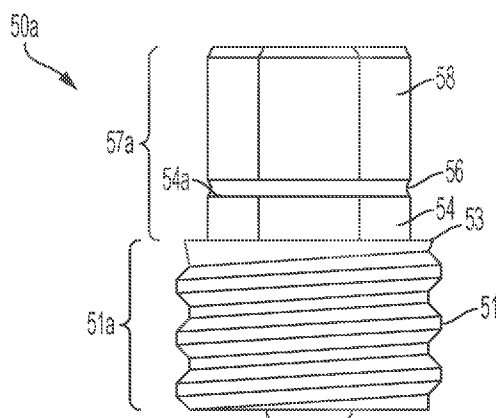

FIG. 15A

(57) Abstract: A load sensing assembly for a spinal implant includes a set screw having a central opening that extends from a first end of the set screw toward a second end of the set screw. The second end of the set screw is configured to engage with an anchoring member. The load sensing assembly includes an antenna, an integrated circuit in communication with the antenna, where the integrated circuit is positioned within the central opening of the set screw, and a strain gauge in connection with the integrated circuit. The strain gauge is located within the central opening of the set screw in proximity to the second end of the set screw.



## BREAK-OFF SET SCREW

### CROSS-REFERENCE TO RELATED U.S. PATENT APPLICATION

[0001] This Application claims benefit to U.S. Nonprovisional Patent Application Serial No. U.S. 16/039,592, entitled "LOAD SENSING ASSEMBLY FOR A SPINAL IMPLANT", filed July 19, 2018, which is incorporated herein by reference in its entirety.

### TECHNICAL FIELD

[0002] The present disclosure generally relates to load sensing assemblies for implant devices, and more particularly to load sensing assemblies for implant devices that are used to treat various spinal disorders.

### BACKGROUND

[0003] Treatment of spinal disorders, such as degenerative disc disease, disc herniations, scoliosis or other curvature abnormalities, and fractures, often requires surgical treatments. For example, spinal fusion may be used to limit motion between vertebral members. As another example, implants may be used to preserve motion between vertebral members.

[0004] Surgical treatment typically involves the use of longitudinal members, such as spinal rods. Longitudinal members may be attached to the exterior of two or more vertebral members to assist with the treatment of a spinal disorder. Longitudinal members may provide a stable, rigid column that helps bones to fuse, and may redirect stresses over a wider area away from a damaged or defective region. Also, rigid longitudinal members may help in spinal alignment.

[0005] Screw assemblies may be used to connect a longitudinal member to a vertebral member. A screw assembly may include a pedicle screw, hook, or other connector and/or a set screw, among other components. A pedicle screw can be placed

in, above and/or below vertebral members that were fused, and a longitudinal member can be used to connect the pedicle screws which inhibits or controls movement. A set screw can be used to secure the connection of a longitudinal member and a pedicle screw, hook or other connector. However, the connection force and continued integrity of the connection between a longitudinal member and a pedicle screw or other connector can be challenging to monitor during and after implantation. In addition, it is difficult to monitor that a proper or acceptable or any force is maintained between a set screw and a longitudinal member.

### SUMMARY

[0006] In an embodiment, a load sensing assembly for a spinal implant includes a set screw having a central opening that extends from a first end of the set screw toward a second end of the set screw. The second end of the set screw is configured to engage with an anchoring member. The load sensing assembly includes an antenna, an integrated circuit in communication with the antenna, where the integrated circuit is positioned within the central opening of the set screw, and a strain gauge in connection with the integrated circuit. The strain gauge is located within the central opening of the set screw in proximity to the second end of the set screw.

[0007] In an embodiment, the antenna may include an opening there through, where the antenna circumferentially surrounds at least a portion of the set screw. Alternatively, at least a portion of the antenna may be positioned in the central opening of the set screw.

[0008] The load sensing assembly may include an electronics component having a top surface, a bottom surface, and one or more electrical circuits. The integrated circuit may be positioned on the top surface of the electronics component. The strain gauge may be operably connected to the bottom surface of the electronics component.

[0009] In an embodiment, the strain gauge may be configured to measure a force between the set screw and a longitudinal member when the set screw is engaged with the anchoring member.

[0010] The integrated circuit may include memory, and the integrated circuit may be configured to store one or more measurements made by the strain gauge in the

memory, and transmit the one or more measurements to a reader when the reader is in proximity to the integrated circuit.

[0011] In an embodiment, the integrated circuit may include memory, and the integrated circuit may be configured to store a unique identifier associated with the set screw in the memory, and transmit the unique identifier to a reader when the reader is in proximity to the integrated circuit.

[0012] In an embodiment, the load sensing assembly may include an anchoring member having a channel that is configured to receive a longitudinal member and a second strain gauge located within the channel. The second strain gauge may be configured to measure a force between the anchoring member and the longitudinal member when positioned in the channel.

[0013] In various embodiments, the integrated circuit may include one or more of the following radio frequency identification (RFID) chip, or a near-field communication (NFC) chip.

[0014] In an embodiment, a load sensing assembly for a spinal implant includes an anchoring member having a head and a base. The head includes a channel that is configured to receive a longitudinal member, and one or more head openings that extend from an external portion of the head into the channel. The load sensing assembly includes an antenna having an opening there through, wherein the antenna circumferentially surrounds at least a portion of the base of the anchoring member, and an integrated circuit in communication with the antenna, where the integrated circuit is positioned within the channel via at least one of the head openings. The load sensing assembly includes a strain gauge located within the channel, where the strain gauge is configured to measure a force between the anchoring member and the longitudinal member when positioned in the channel.

[0015] Optionally, the load sensing assembly may include an electronics component having one or more electrical circuits. The integrated circuit may be connected to the electronics component. The strain gauge may be operably connected to the electronics component via a connecting member.

[0016] In an embodiment, the integrated circuit may include memory, and the integrated circuit may be configured to store one or more measurements made by the

strain gauge in the memory, and transmit the one or more measurements to a reader when the reader is in proximity to the integrated circuit.

[0017] In an embodiment, the integrated circuit may include memory, and the integrated circuit may be configured to store a unique identifier associated with the anchoring member in the memory, and transmit the unique identifier to a reader when the reader is in proximity to the integrated circuit.

[0018] A load sensing assembly may further include a set screw having a central opening that extends from a first end of the set screw toward a second end of the set screw, where the second end of the set screw may be configured to engage with the anchoring member, and a second strain gauge located within the central opening of the set screw in proximity to the second end of the set screw.

[0019] In an embodiment, the integrated circuit may include one or more of the following radio frequency identification (RFID) chip, or a near-field communication (NFC) chip.

[0020] In an embodiment, a load sensing assembly for a spinal implant includes an antenna, an electronics component having one or more electrical circuits that is operably connected to the antenna, an integrated circuit operably connected to at least a portion of the electronics component, and a strain gauge in communication with the integrated circuit, where the strain gauge is configured to measure a force between the implant and a longitudinal member.

[0021] The electronics component may be operably connected to the antenna via a connecting member that extends perpendicularly to the antenna. The antenna may include a radio frequency identification coil, and the antenna may be configured to circumferentially surround at least a portion of a set screw or a pedicle screw.

[0022] In an embodiment, at least a portion of the antenna may be positioned in a central opening of a set screw.

[0023] In an embodiment, the integrated circuit may include memory, and the integrated circuit may be configured to store one or more measurements made by the strain gauge in the memory, and transmit the one or more measurements to a reader when the reader is in proximity to the integrated circuit.

[0024] The integrated circuit may include memory, and the integrated circuit may be configured to store a unique identifier associated with the implant in the memory, and transmit the unique identifier to a reader when the reader is in proximity to the integrated circuit.

[0025] In an embodiment, a load sensing assembly for a spinal implant includes a break-off set screw including a break-off head coupled to an adjustment head via a break-off region, and a bore extending from an outer surface of the break-off head to a threaded portion of the break-off set screw. In one or more cases, the load sensing assembly includes an antenna. In one or more cases, the load sensing assembly includes an integrated circuit in communication with the antenna. In one or more cases, the integrated circuit and strain gauge are positioned within the bore of the set screw. In one or more cases, the threaded portion of the break-off set screw is configured to fasten to an anchoring member.

[0026] In an embodiment, load sensing assembly for a spinal implant includes a break-off set screw including a break-off head coupled to an adjustment head via a break-off region, and a bore extending from an outer surface of the break-off head to a threaded portion of the break-off set screw. In one or more cases, the load sensing assembly includes an antenna. In one or more cases, the load sensing assembly includes an integrated circuit in communication with the antenna. In one or more cases, the load sensing assembly includes a strain gauge in connection with the integrated circuit. In one or more cases, the integrated circuit and strain gauge are positioned within the bore of the set screw. In one or more cases, the threaded portion of the break-off set screw is configured to fasten to an anchoring member. In one or more cases, an outer surface of the break-off head is aligned with an outer surface of the adjustment head.

[0027] In an embodiment, a load sensing assembly for a spinal implant includes a break-off set screw including a break-off head coupled to an adjustment head via a break-off region, and a bore extending from an outer surface of the break-off head to a threaded portion of the break-off set screw. In one or more cases, the load sensing assembly includes an antenna. In one or more cases, the load sensing assembly includes an integrated circuit in communication with the antenna. In one or more cases, the load sensing assembly includes a strain gauge in connection with the integrated circuit. In one

or more cases, the integrated circuit and strain gauge are positioned within the bore of the set screw. In one or more cases, the threaded portion of the break-off set screw is configured to fasten to an anchoring member. In one or more cases, an outer surface of the break-off head is aligned with an outer surface of the adjustment head.

#### BRIEF DESCRIPTION OF THE DRAWINGS

[0028] FIG. 1 illustrates an example anchoring assembly and longitudinal member according to an embodiment.

[0029] FIG. 2 illustrates an example exploded view of a screw assembly and longitudinal member according to an embodiment.

[0030] FIG. 3 illustrates an example load sensing assembly for a set screw according to an embodiment.

[0031] FIGS. 4A and 4B illustrates a load sensing assembly mounted to a set screw according to an embodiment.

[0032] FIG. 5 illustrates a top view of a load sensing assembly mounted to a set screw according to an embodiment.

[0033] FIG. 6 illustrates an example load sensing assembly according to an embodiment.

[0034] FIG. 7 illustrates a different perspective of a load sensing assembly for an anchoring member according to an embodiment.

[0035] FIG. 8 illustrates a load sensing assembly connected to an anchoring member according to an embodiment.

[0036] FIG. 9 illustrates a screw assembly set screw having a load sensing assembly and connected to an anchoring member that also has a load sensing assembly mounted to it according to an embodiment.

[0037] FIG. 10 illustrates a side view of the screw assembly shown in FIG. 9 according to an embodiment.

[0038] FIG. 11 illustrates a non-transparent view of the screw assembly shown in FIG. 9 according to an embodiment.

[0039] FIG. 12 illustrates an example hook member having a load sensing assembly according to an embodiment.

[0040] FIGs. 13A and 13B each illustrate an example set screw according to an embodiment.

[0041] FIG. 14 illustrates an example anchoring member according to an embodiment.

[0042] FIG. 15A illustrates a side view of an example break-off set screw according to an embodiment. FIG. 15B illustrates a top view of the example set screw illustrated in FIG. 15A according to an embodiment.

[0043] FIG. 16A illustrates a side view of an example break-off set screw with an offset break-off head according to an embodiment. FIG. 16B illustrates a top view of the example break-off set screw with an offset break-off head illustrated in FIG. 16A according to an embodiment.

#### DETAILED DESCRIPTION

[0044] The exemplary embodiments of the surgical system and related methods of use disclosed are discussed in terms of medical devices for the treatment of musculoskeletal disorders and more particularly, in terms of a vertebral fixation screws, including for example pedicle screws, as well as hooks, cross connectors, offset connectors and related systems for use during various spinal procedures or other orthopedic procedures and that may be used in conjunction with other devices and instruments related to spinal treatment, such as rods, wires, plates, intervertebral implants, and other spinal or orthopedic implants, insertion instruments, specialized instruments such as, for example, delivery devices (including various types of cannula) for the delivery of these various spinal or other implants to the vertebra or other areas within a patient in various directions, and/or a method or methods for treating a spine, such as open procedures, mini-open procedures, or minimally invasive procedures. Exemplary prior art devices that may be modified to include the various embodiments of load sensing systems include, for example, U.S. Patents 6,485,491 and 8,057,519, all incorporated herein by reference in their entirety.

[0045] The present disclosure may be understood more readily by reference to the following detailed description of the embodiments taken in connection with the accompanying drawing figures, which form a part of this disclosure. It is to be understood



that this application is not limited to the specific devices, methods, conditions or parameters described and/or shown herein, and that the terminology used herein is for the purpose of describing particular embodiments by way of example only and is not intended to be limiting.

[0046] In some embodiments, as used in the specification and including the appended claims, the singular forms “a,” “an,” and “the” include the plural, and reference to a particular numerical value includes at least that particular value, unless the context clearly dictates otherwise. Ranges may be expressed herein as from “about” or “approximately” one particular value and/or to “about” or “approximately” another particular value. When such a range is expressed, another embodiment includes from the one particular value and/or to the other particular value. Similarly, when values are expressed as approximations, by use of the antecedent “about,” it will be understood that the particular value forms another embodiment. It is also understood that all spatial references, such as, for example, horizontal, vertical, top, upper, lower, bottom, left and right, are for illustrative purposes only and can be varied within the scope of the disclosure. For example, the references “upper” and “lower” are relative and used only in the context to the other, and are not necessarily “superior” and “inferior”. Generally, similar spatial references of different aspects or components indicate similar spatial orientation and/or positioning, *i.e.*, that each “first end” is situated on or directed towards the same end of the device. Further, the use of various spatial terminology herein should not be interpreted to limit the various insertion techniques or orientations of the implant relative to the positions in the spine.

[0047] The following discussion includes a description of a vertebral pedicle screw system and related components and methods of employing the vertebral pedicle screw in accordance with the principles of the present disclosure. Reference is made in detail to the exemplary embodiments of the present disclosure, which are illustrated in the accompanying figures.

[0048] The components of the vertebral pedicle screw system described herein can be fabricated from biologically acceptable materials suitable for medical applications, including metals, synthetic polymers, ceramics and bone material and/or their composites. For example, the components of the vertebral pedicle screw system,

individually or collectively, can be fabricated from materials such as stainless steel alloys, commercially pure titanium, titanium alloys, Grade 5 titanium, super-elastic titanium alloys, cobalt-chrome alloys, stainless steel alloys, superelastic metallic alloys (e.g., Nitinol, super elasto-plastic metals, such as GUM METAL®), ceramics and composites thereof such as calcium phosphate (e.g., SKELITE™), thermoplastics such as polyaryletherketone (PAEK) including polyetheretherketone (PEEK), polyetherketoneketone (PEKK) and polyetherketone (PEK), carbon-PEEK composites, PEEK-BaSO<sub>4</sub> polymeric rubbers, polyethylene terephthalate (PET), fabric, silicone, polyurethane, silicone-polyurethane copolymers, polymeric rubbers, polyolefin rubbers, hydrogels, semi-rigid and rigid materials, elastomers, rubbers, thermoplastic elastomers, thermoset elastomers, elastomeric composites, rigid polymers including polyphenylene, polyamide, polyimide, polyetherimide, polyethylene, epoxy, bone material including autograft, allograft, xenograft or transgenic cortical and/or corticocancellous bone, and tissue growth or differentiation factors, partially resorbable materials, such as, for example, composites of metals and calcium-based ceramics, composites of PEEK and calcium based ceramics, composites of PEEK with resorbable polymers, totally resorbable materials, such as, for example, calcium based ceramics such as calcium phosphate, tri-calcium phosphate (TCP), hydroxyapatite (HA)-TCP, calcium sulfate, or other resorbable polymers such as polyacetide, polyglycolide, polytyrosine carbonate, polycaprolactone and their combinations.

[0049] Various components of the vertebral pedicle screw system may be formed or constructed material composites, including the above materials, to achieve various desired characteristics such as strength, rigidity, elasticity, compliance, biomechanical performance, durability and radiolucency or imaging preference. The components of the present vertebral pedicle screw system, individually or collectively, may also be fabricated from a heterogeneous material such as a combination of two or more of the above-described materials. The components of the vertebral pedicle screw system may be monolithically formed, integrally connected or include fastening elements and/or instruments, as described herein. The components of the vertebral pedicle screw system may be formed using a variety of subtractive and additive manufacturing techniques, including, but not limited to machining, milling, extruding, molding, 3D-printing, sintering,

coating, vapor deposition, and laser/beam melting. Furthermore, various components of the vertebral pedicle screw system may be coated or treated with a variety of additives or coatings to improve biocompatibility, bone growth promotion or other features. To the extent the plate is entirely or partially radiolucent, it may further include radiographic markers made, for example of metallic pins, at one or both ends, on each corner of the ends, and/or along the length of the implant in various locations including near the center of the assembly.

[0050] The vertebral pedicle screw system may be employed, for example, with a minimally invasive procedure, including percutaneous techniques, mini-open and open surgical techniques to deliver and introduce instrumentation and/or one or more spinal implants at a surgical site within a body of a patient, for example, a section of a spine. In some embodiments, the vertebral pedicle screw system may be employed with surgical procedures, as described herein, and/or, for example, corpectomy, discectomy, fusion and/or fixation treatments that employ spinal implants to restore the mechanical support function of vertebrae. In some embodiments, the pedicle screw system may be employed with surgical approaches, including but not limited to: anterior lumbar interbody fusion (ALIF), direct lateral interbody fusion (DLIF), oblique lateral lumbar interbody fusion (OLLIF), oblique lateral interbody fusion (OLIF), various types of anterior fusion procedures, and any fusion procedure in any portion of the spinal column (sacral, lumbar, thoracic, and cervical, for example).

[0051] FIG. 1 illustrates an example anchoring assembly and longitudinal member according to an embodiment. As illustrated in FIG. 1, an anchoring assembly includes a screw 20 and an anchoring member 30. The screw 20 has an elongated shape with a first end mounted within a vertebral member 200 and a second end extending outward above the vertebral member 200. The anchoring member 30 is configured to operatively connect to the second end of the screw 20 and is movably connected to the screw 20 to accommodate the longitudinal member 100 positioned at various angular positions. The anchoring member 30 includes a channel 31 sized to receive the longitudinal member 100. A set screw 50 attaches to the anchoring member 30 to capture the longitudinal member 100 within the channel 31.

[0052] FIG. 2 illustrates an example exploded view of a screw assembly and longitudinal member according to an embodiment. As shown by FIG. 2, anchoring member 30 provides a connection between the screw 20 and longitudinal member 100. Anchoring member 30 includes a first end 32 that faces towards the vertebral member 200, and a second end 33 that faces away. A chamber is positioned between the first and second ends 32, 33 and is sized to receive at least a portion of the screw 20. In various embodiments, a first end 32 may be considered a base portion of an anchoring member 30, and a second end 33 may be considered a head portion of an anchoring member.

[0053] The second end 33 of the anchoring member 30 includes a channel 31 sized to receive the longitudinal member 100. Channel 31 terminates at a lower edge 38 that may include a curved shape to approximate the longitudinal member 100. Threads 37 may be positioned towards the second end 33 to engage with the set screw 50. In one embodiment as illustrated in FIG. 2, the threads 37 are positioned on the interior of the anchoring member 30 facing towards the channel 31. In another embodiment, the threads 37 may be on the exterior of the anchoring member 30. An interior of the anchoring member 30 may be open between the first and second ends 32, 33.

[0054] In various embodiments, an anchoring member 30 may include a washer 60. A washer 60 may be generally cylindrical and may have a hole 66 there through. As illustrated by FIG. 1 a washer 60 may be positioned near a first end 32 of an anchoring member 30. A screw 20 may engage with an anchoring member 30 via positioning through the hole 66 of a washer 60. A washer 60 may include recessed portions which may be configured to accommodate placement of a longitudinal member 100 therein. The use of a washer 60 in connection with an anchoring member 30 may help minimize misalignment of the longitudinal member within the anchoring member.

[0055] In an embodiment, set screw 50 attaches to the anchoring member 30 and captures the longitudinal member 100 within the channel 31. As illustrated in FIG. 2, the set screw 50 may be sized to fit within the interior of the channel 31 and include exterior threads 51 that engage threads 37 on the anchoring member 30. A driving feature 52 may be positioned on a top side to receive a tool during engagement with the

anchoring member 30. In some embodiments, the set screw 50 may be mounted on an exterior of the anchoring member 30. Set screw 50 includes a central opening and is sized to extend around the second end 33. A set screw 50 may be a break-off set screw or a non-break-off set screw. In certain embodiments, a set screw 50 may include a slot 53 for receiving or routing of electronic connections as illustrated in FIGs. 13A and 13B. Threads 51 are positioned on an inner surface of the central opening to engage with the external threads 37 on the anchoring member 30. The set screw 50 and anchoring member 30 may be constructed for the top side of the set screw 50 to be flush with or recessed within the second end 33 when mounted with the anchoring member 30. FIG. 13A illustrates an example set screw 50 having an antenna 300 positioned on an external portion of the set screw. FIG. 13B illustrates an example set screw 50 having an antenna 300 positioned internally in a central opening of the set screw.

[0056] FIG. 3 illustrates an example load sensing assembly for a set screw according to an embodiment. As illustrated by FIG. 3, a load sensing assembly may include an antenna 300, such as a radio frequency identification (RFID) coil, a near field-communication (NFC) antenna or other short-range communication transmitter and/or receiver. A load sensing assembly may include one or more integrated circuits 302 such as, for example, an RFID chip 302 or an NFC chip. A load sensing assembly may include one or more electronics components 304 and/or a strain gauge 306, such as for example a silicon strain gauge. A strain gauge 306 may be a device that measures strain on an object. For instance, a strain gauge 306 may measure a force between a set screw and a longitudinal member when the set screw is engaged with an anchoring member. A strain gauge 306 may include one or more sensors or sensor nodes that measure strain, force, resistance, load and or the like.

[0057] In an embodiment, one or more of the electronics components 304 may include a flexible electronics component, such as, for example, a flex circuit or one or more electrical circuits. The antenna 300 may be operably connected to the electronics component 304 via a connecting member 308. For instance, as shown in FIG. 3, the connecting member 308 may be connected to both the antenna 300 and the electronics component 304. The connecting member 308 may be positioned perpendicularly to both the antenna 300 and the electronics component 304. In various embodiments, a

connecting member 308 and an antenna 300 and/or electronics component 304 may be constructed integrally or may be separately constructed and attached together in any suitable manner, such as for example by adhesive, chemical, mechanical or cement bonding.

[0058] The integrated circuit 302 may be operably connected to the electronics component 304. For instance, as illustrated in FIG. 3, an electronics component 304 may have a top surface 310 and a bottom surface 312. An integrated circuit 302 may be positioned on the top surface 310 of an electronics component 304, and may be connected to the top surface in any suitable manner, including, for example, adhesive, chemical, mechanical or cement bonding. An integrated circuit 302 may include memory according to an embodiment. The memory may be used to store various information. For example, one or more measurements of a strain gauge 306 may be stored in memory. As another example, a unique identifier associated with a load sensing assembly, a component thereof, or a set screw may be stored in memory. Additional and/or alternate information or types of information may be stored according to this disclosure.

[0059] A strain gauge 306 may be operably connected, for example by adhesive, cement, mechanical or chemical bonding, to the electronics component 304. For instance, a strain gauge 306 may be operably connected to the electronics component 304 via the bottom surface 312 of the electronics component 304. A strain gauge 306 may be connected to the bottom surface 312 of an electronics component 304 in any suitable manner including, without limitation, via an adhesive bonding agent.

[0060] As shown in FIG. 3, an antenna 300 may have a generally curved shape. The antenna 300 may include a first end and a second end. The antenna 300 may include an opening that extends from the first end toward the second end.

[0061] As illustrated in FIG. 4A, a load sensing assembly may be configured to be mounted to a set screw. The antenna 300 is sized to extend around the set screw such that the integrated circuit 302, electronics component 304, strain gauge 306 and connecting member 308 are positioned within the central opening of the set screw as illustrated in FIG. 4A. As illustrated in FIG. 4A, the antenna 300 may circumferentially surround at least a portion of the exterior of the set screw. In other embodiments, as

illustrated by FIG. 4B, the antenna 300 may be positioned at least partially inside of the central opening of a set screw.

[0062] In certain embodiments, the strain gauge 306 may be connected to a portion of the central opening of the set screw in any suitable manner including, without limitation via an adhesive. The strain gauge 306 may be connected to a portion of the central opening such that it is positioned to measure a force between the set screw and a longitudinal rod when the set screw engages with an anchoring member. FIG. 5 illustrates a top view of a load sensing assembly mounted to a set screw according to an embodiment.

[0063] FIG. 6 illustrates an example load sensing assembly according to an embodiment. The load sensing assembly illustrated in FIG. 6 may be mounted to an anchoring member according to various embodiments. Example anchoring members may include, without limitation screws, hooks, offset connectors, cross connectors, or other types of anchors or implants. As illustrated in FIG. 6, a load sensing assembly for an anchoring member may include an antenna 600, such as a RFID coil, an NFC antenna or other short-range communication transmitter and/or receiver. A load sensing assembly may include an integrated circuit 602, one or more electronics components 604 and/or a strain gauge 606. In an embodiment, one or more of the electronics components 604 may include a flexible electronics component, such as, for example, a flexible circuit or one or more electrical circuits.

[0064] The electronics component 604 may be connected to the antenna 600 via a connecting member 608. As shown in FIG. 6, a connecting member 608 may position an electronics component perpendicularly to the antenna 600. A connecting member 608 may include a first portion 610 that attaches to an antenna 600 and extends substantially vertically and perpendicularly from the antenna. The connecting member 608 may include a second portion 612 connected to the first portion and the electronics component. The second portion 612 may extend substantially horizontally and perpendicularly to the first portion 610. The electronics component 604 may be positioned substantially perpendicularly to the second portion 612. A connecting member 608 may be constructed integrally with an antenna 600 and/or electronics component 604, or may be separately constructed and attached together in any suitable manner.

[0065] In various embodiments, the integrated circuit 602 may be connected to a first surface 614 of the electronics component 604 as illustrated in FIG. 6. The RFID chip 602 may be connected to a first surface 614 of an electronics component in any suitable manner. An integrated circuit 602 may include memory according to an embodiment. The memory may be used to store various information. For example, one or more measurements of a strain gauge 606 may be stored in memory. As another example, a unique identifier associated with a load sensing assembly, a component thereof, or an anchoring member may be stored in memory. Additional and/or alternate information or types of information may be stored according to this disclosure.

[0066] A strain gauge 606 may be connected to an electronics component 604 via a second connecting member 616. As illustrated in FIG. 6, a second connecting member 616 may include a first portion 618, a second portion 620 and a third portion 622. The first portion 618 may connect to the electronics component 604 and may extend substantially perpendicularly to the electronics component. The second portion 620 of the second connecting member 616 may be connected to the first portion 618 of the second connecting member and may extend substantially perpendicular thereto. The third portion 622 of the second connecting member 616 may be connected to the second portion 620 of the second connecting member, and may extend substantially perpendicular to the second portion.

[0067] The third portion 622 of the second connecting member 616 may have a top surface 624 and a bottom surface 626. A strain gauge 606 may be connected to the bottom surface 626 in any suitable manner. The strain gauge 606 may be configured to measure a force between the set screw and a longitudinal member. FIG. 7 illustrates a different perspective of a load sensing assembly for an anchoring member according to an embodiment.

[0068] As illustrated in FIG. 8, a load sensing assembly may be connected to an anchoring member 30. For example, a load sensing assembly may be connected to an anchoring member near a first end 32 of the anchoring member. The antenna 600 is sized to extend around the anchoring member 30, for example, near the first end 32. In various embodiments, an antenna 600 may be securely fitted around a portion of the



anchoring member 30. In other embodiments, an antenna 600 may be secured to the anchoring member in any other suitable manner.

[0069] The antenna 600 may be positioned on the anchoring member 30 such that the integrated circuit 602 and electronics component 604 are positioned within an opening of the anchoring member 30. For instance, as illustrated by FIG. 8, an anchoring member 30 may have one or more openings 800 that extend from an outer portion of the anchoring member into the channel 31 of the anchoring member. As illustrated by FIG. 8, the second portion of the first connecting member may extend into the opening 800 and may position the integrated circuit and/or the electronics component within the opening and/or the channel 31. Such a positioning may result in the strain gauge 606 being positioned in the channel 31 at a location where it is possible to measure a force of a longitudinal member in the channel. In an alternate embodiment, a strain gauge 606 may be positioned on or attached to a washer or pressure ring 611 within an anchoring member as illustrated by FIG. 14. In yet another embodiment, in situations where an anchoring member includes a hook member, a strain gauge 606 may be positioned on or attached to a hook portion of the hook member. Measurements obtained by the strain gauge 606 may be used to determine whether a longitudinal member is properly seated and/or torqued during and/or after implant.

[0070] In various embodiments, a set screw having a load sensing assembly may be used with in connection with an anchoring member with or without a load, sensing assembly. FIG. 9 illustrates a set screw having a load sensing assembly engaged with an anchoring member that also has a load sensing assembly according to an embodiment. So that components of each can be clearly depicted, a longitudinal member is not shown in FIG. 9. FIG. 10 illustrates a side view of the screw assembly shown in FIG. 9 according to an embodiment. FIG. 11 illustrates a non-transparent view of the screw assembly shown in FIG. 9 according to an embodiment. Although FIGs. 9-11 illustrate an antenna located externally to a set screw, it is understood that the antenna may alternatively be located within at least a portion of the central opening of the set screw.

[0071] FIGS. 1-11 illustrate a multi-axial tulip-head pedicle screw according to various embodiments. However, it is understood that other types of anchoring members may be used within the scope of this disclosure. For example, fixed head screws or

screws having differently shaped heads may be used. As another example, a hook member, a cross-link connector, an offset connector, or a hybrid hook-screw member may be used as well. FIG. 12 illustrates an example hook member having a load sensing assembly according to an embodiment.

[0072] In various embodiments, one or more measurements obtained by a strain gauge may be stored by an integrated circuit of a corresponding load sensing assembly such as, for example, in its memory. The integrated circuit may be interrogated by a reader. For instance, an RFID chip may be read by an RFID reader. As another example, an NFC chip may be read by or may otherwise communicate with an NFC reader or other NFC-enabled device. A reader may interrogate an integrated circuit when in a certain proximity to the integrated circuit. In certain embodiments, a reader may interrogate an integrated circuit that has been implanted into a patient as part of a set screw or anchoring member assembly. In other embodiments, an integrated circuit may communicate with a reader or other electronic device without being interrogated.

[0073] An integrated circuit may transmit one or more measurements to the reader. This transmission may occur in response to being interrogated by the reader, or the transmission may be initiated by the integrated circuit. The reader may receive the transmitted measurements, and may cause at least a portion of the measurements to be displayed to a user. For instance, a physician may use a reader to interrogate an RFID chip of a patient's implant. The reader may include a display, or may be in communication with a display device, which may display at least a portion of the measurements received from the RFID chip.

[0074] An integrated circuit may be passive, meaning that the chip has no internal power source and is powered by the energy transmitted from a reader. With respect to an assembly having a passive integrated circuit, the integrated circuit may not transmit information until interrogated by a reader.

[0075] In another embodiment, an integrated circuit may be active, meaning that the chip is battery-powered and capable of broadcasting its own signal. An active integrated circuit may transmit information in response to being interrogated by a reader, but also on its own without being interrogated. For instance, an active integrated circuit may broadcast a signal that contains certain information such as, for example, one or more

measurements gathered by an associated strain gauge. An active integrated circuit may continuously broadcast a signal, or it may periodically broadcast a signal. Power may come from any number of sources, including, for example, thin film batteries with or without encapsulation or piezo electronics.

[0076] In various embodiments, one or more sensors of a strain gauge may transmit information by directly modulating a reflected signal, such as an RF signal. The strain gauge sensors may form a Wireless Passive Sensor Network (WPSN), which may utilize modulated backscattering (MB) as a communication technique. External power sources, such as, for example, an RF reader or other reader, may supply a WPSN with energy. The sensor(s) of the WPSN may transmit data by modulating the incident signal from a power source by switching its antenna impedance.

[0077] One or more measurements received from a load sensing assembly may be used to make determinations of the condition of a spinal implant and/or treatment of a spinal disorder. For instance, proper placement of a longitudinal member, set screw and/or anchoring member may result in an acceptable range of force measurements collected by a strain gauge of a load sensing assembly. Measurements outside of this range may indicate a problem with the placement or positioning of a longitudinal member, set screw and/or anchoring member such as, for example, loosening of a set screw and/or anchoring member, longitudinal member failure, construct failure, yield or fracture/breakage, improper torque, breakage of the bone segment or portion, the occurrence of fusion or amount of fusion, and/or the like.

[0078] One or more tools or instruments may include a reader which may be used to gather information from one or more integrated circuit during or in connection with a procedure. For instance, a torque tool may be used to loosen or tighten a set screw. A torque tool may include a reader, or may be in communication with a reader, such that a user of the torque tool is able to obtain, in substantially real time, one or more measurements relating to the set screw and longitudinal rod placement that are measured by a strain gauge of a load sensing assembly of the set screw via the tool. For instance, as a user is applying torque to a set screw, the user may see one or more force measurements between the set screw and the longitudinal member in order to determine that the positioning of the set screw and/or longitudinal member is correct and that the

proper force is being maintained. In certain embodiments, a tool or instrument may include a display device on which one or more measurements may be displayed. In other embodiments, a tool or instrument may be in communication with a display device, and may transmit one or more measurements for display on the display device via a communications network.

[0079] In some embodiments, an electronic device, such as a reader or an electronic device in communication with a reader, may compare one or more measurements obtained from an integrated circuit to one or more acceptable value ranges. If one or more of the measurements are outside of an applicable value range, the electronic device may cause a notification to be made. For instance, an electronic device may generate an alert for a user, and cause the alert to be displayed to the user via a display device. Alternatively, an electronic device may send an alert to a user such as via an email message, a text message or otherwise.

[0080] An integrated circuit of a load sensing assembly may store a unique identifier associated with the component to which the load sensing assembly corresponds. For instance, an integrated circuit of a load sensing assembly for a set screw may store a unique identifier associated with the set screw. Similarly, an integrated circuit of a load sensing assembly for an anchoring member may store a unique identifier associated with the anchoring member. The integrated circuit may transmit the unique identifier to an electronic device. For instance, when a reader interrogates an integrated circuit, the integrated circuit may transmit a unique identifier for a component that is stored by the integrated circuit to the reader.

[0081] Having access to a unique identifier for a component may help a user ascertain whether the measurements that are being obtained are associated with the component of interest. Also, having access to a unique identifier for a component may help a user take inventory of one or more components. For instance, after spinal surgery, a physician or other health care professional may use a reader to confirm that all of the set screws and anchoring members allocated for the procedure have been used and are positioned in a patient.

[0082] FIG. 15A illustrates a side view of an example break-off set screw 50a according to an embodiment. FIG. 15B illustrates a top view of the example set screw 50a illustrated in FIG. 15A according to an embodiment.

[0083] In an embodiment, the set screw 50a attaches to the anchoring member 30 and captures the longitudinal member 100 within the channel 31. The set screw 50a may be sized to fit within the interior of the channel 31 and include exterior threads 51 that engage threads 37 on the anchoring member 30.

[0084] The driving feature 57a of the set screw 50a may include a break-off head 58 coupled to an adjustment head 54 via a break-off region 56. The driving feature 57a may be positioned on top of the proximal end of the external threads 51. The driving feature 57a is configured to receive a tool, such as a screw driver, during engagement with the anchoring member 30. The driving feature 57a may include a bore 59 that extends from an outer top surface of the break-off head 58 and into a portion of the threaded portion 51a of the set screw 50a. In one or more cases, the bore 59 may have a cylindrically shaped opening when viewed from a top surface of the set screw 50a. In one or more other cases, the bore 59 may have a star shaped opening, e.g., a shape to receive a hexalobe screw driver, with an inner cylindrically shaped opening when viewed from a top surface of the set screw 50a. The bore 59 may provide a working area for placing one or more sensors, such as strain gauges, within the set screw 50a. For the cases in which the bore 59 has a star shaped opening with an inner cylindrically shaped opening, the working area of the inner cylindrically shaped opening may be 2 to 5 mm in diameter, and more preferably at or about 3.65 mm in diameter. For the cases in which the bore 59 has a cylindrically shaped opening, the working area for the cylindrically shaped opening may be 3 to 7 mm in diameter, and more preferably at or about 5.35 mm in diameter. For the cases in which strain gauges are used as sensors in the driving feature 57a having the cylindrically shaped bore 59, the strain gauges may experience higher strain values than a driving feature 57a having the star shaped opening with an inner cylindrically shaped bore 59.

[0085] The break-off head 58 may have an external shape configured to engage with a tool, such as a screw driver, to rotate the break-off head 58. The break-off head 58 may be configured in an external shape to enable a positive, non-slip engagement of the

break-off head 58 by the tool. For example, in one or more cases, the outer perimeter of the break-off head 58 may be configured in a hexagonal shape. In one or more other cases for example, the outer perimeter, that is, the outer surface, of the break-off head 58 may be configured in a square shape, pentagonal shape, star shape, or the like. The break-off head 58 may include a slot, similar to slot 53, for receiving or routing electronic connections as illustrated in FIGs. 13A and 13B.

[0086] The adjustment head 54 may be configured to remain attached to the set screw portion 51a subsequent to breaking off the break-off head 54 from the set screw 50a. In one or more cases, the set screw portion 51a may be configured to seat into the anchoring member 30 far enough that the upper surface 53 of the set screw portion 51a is flush with or recessed within the second end 33 when fastened to the anchoring member 30. The upper surface 53 of the set screw portion 51a may be the surface interfacing between the set screw portion 51a and the driving feature 57a. In one or more other cases, the set screw 50a may be configured to seat into the anchoring member 30 far enough that the upper surface 54a of the adjustment head 54 is flush with or recessed within the second end 33 when fastened to the anchoring member 30. The adjustment head 54 may have an external shape configured to engage with a tool to rotate the adjustment head 54. The adjustment head 54 may be configured in an external shape to enable a positive, non-slip engagement of the adjustment head 54 by the tool. For example, in one or more cases, the outer perimeter of the adjustment head 54 may be configured in a hexagonal shape. In one or more other cases for example, the outer perimeter of the adjustment head 54 may be configured in a square shape, pentagonal shape, star shape, or the like. The adjustment head 54 may include a slot, similar to slot 53, for receiving or routing electronic connections as illustrated in FIGs. 13A and 13B.

[0087] In one or more cases, the external shape of the break-off head 58 may have the same external shape and size as the adjustment head 54. The external shape of the break-off head 58 may be the aligned with the external shape of the adjustment head 54, such that the outer surfaces of the break-off head 58 are parallel with the outer surfaces of the adjustment head 54. In one or more cases, the length of the break-off head 58 may be greater than the length of the adjustment head 54. In one or more cases, the length of the break-off head 58 may have the same length as the length of the adjustment head

54. In one or more other cases, the perimeter of the external shape of the break-off head 58 may be larger than the perimeter of the adjustment head 54. In one or more other cases, the perimeter of the external shape of the break-off head 58 may be smaller than the perimeter of the adjustment head 54.

[0088] The break-off region 56 may be a scored portion of the driving feature 57a, where the adjustment head 54 and the break-off head 58 are configured to separate. The driving feature 57a, and in particular, the break-off region 56, may be configured to withstand an amount of torque being applied to the driving feature 57a while engaging the longitudinal member 100 to the anchoring member 30 and fastening the set screw 50a to the anchoring member 30. The break-off region 56 may be configured to break when an amount of torque is applied to the break-off head 58, thereby separating the break-off head 58 from the adjustment head 54. For example, the break-off region 56 may be configured to break at or about 9 to 12 Newton meters (N m), and more preferably at or about 11 N m, of torque.

[0089] In one or more cases, the tool may fasten the set screw 50a to the anchoring member 30 by rotating the set screw 50a into the anchoring member 30. Having reached an amount of torque at the break-off region 56 configured to separate the break-off head 58 and the adjustment head 54, the break-off head 58 is broken off thereby separating the break-off head 58 from the adjustment head 54 at the break-off region 56 and leaving the adjustment head 54 fastened to the anchoring member 30. Subsequently, the tool may be engaged with the adjustment head 54 to further tighten and/or loosen the adjustment head 54 from the anchoring member 30.

[0090] FIG. 16A illustrates a side view of an example break-off set screw 50b with an offset break-off head 55 according to an embodiment. FIG. 16B illustrates a top view of the example break-off set screw 50b with an offset break-off head 55 illustrated in FIG. 16A according to an embodiment.

[0091] In an embodiment, set screw 50b attaches to the anchoring member 30 and captures the longitudinal member 100 within the channel 31. The set screw 50b may be sized to fit within the interior of the channel 31 and include exterior threads 51 that engage threads 37 on the anchoring member 30.

[0092] The driving feature 57b of the set screw 50b may include an offset break-off head 55 coupled to an adjustment head 54 via a break-off region 56. The driving feature 57b may be positioned on top of the proximal end of the external threads 51. The driving feature 57b is configured to receive a tool, such as a screw driver, during engagement with the anchoring member 30. The driving feature 57b may include a bore 59 that extends from an outer top surface of the offset break-off head 55 and into a portion of the threaded portion 51b of the set screw 50b. In one or more cases, the bore 59 may have a cylindrically shaped opening when viewed from a top surface of the set screw 50b. In one or more other cases, the bore 59 may have a star shaped opening, e.g., a shape to receive a hexalobe screw driver, with an inner cylindrically shaped opening when viewed from a top surface of the set screw 50b. The bore 59 may provide a working area for placing one or more sensors, such as strain gauges, within the set screw 50b. For the cases in which the bore 59 has a star shaped opening with an inner cylindrically shaped opening, the working area of the inner cylindrically shaped opening may be 2 to 5 mm in diameter, and more preferably at or about 3.65 mm in diameter. For the cases in which the bore 59 has a cylindrically shaped opening, the working area for the cylindrically shaped opening may be 3 to 7 mm in diameter, and more preferably at or about 5.35 mm in diameter. For the cases in which strain gauges are used as sensors in the driving feature 57b having the cylindrically shaped bore 59, the strain gauges may experience higher strain values than a driving feature 57b having the star shaped opening with an inner cylindrically shaped bore 59.

[0093] The offset break-off head 55 may have an external shape configured to engage with a tool, such as a screw driver, to rotate the offset break-off head 55. The offset break-off head 55 may be configured in an external shape to enable a positive, non-slip engagement of the offset break-off head 55 by the tool. For example, in one or more cases, the outer perimeter of the offset break-off head 55 may be configured in a hexagonal shape. In one or more other cases for example, the outer perimeter of the offset break-off head 55 may be configured in a square shape, pentagonal shape, star shaped, or the like. The offset break-off head 55 may include a slot, similar to slot 53, for receiving or routing electronic connections as illustrated in FIGs. 13A and 13B.



[0094] The adjustment head 54 may be configured to remain attached to the set screw portion 51b subsequent to the break-off head 54 breaking off from the set screw 50b. In one or more cases, the set screw portion 51b may be configured to seat into the anchoring member 30 far enough that the upper surface 53 of the set screw portion 51b is flush with or recessed within the second end 33 when fastened to the anchoring member 30. The upper surface 53 of the set screw portion 51a may be the surface interfacing between the set screw portion 51b and the driving feature 57b. In one or more other cases, the set screw 50b may be configured to seat into the anchoring member 30 far enough that the upper surface 54a of the adjustment head 54 to be flush with or recessed within the second end 33 when fastened to the anchoring member 30. The adjustment head 54 may have an external shape configured to engage with a tool to rotate the adjustment head 54. The adjustment head 54 may be configured in an external shape to enable a positive, non-slip engagement of the adjustment head 54 by the tool. For example, in one or more cases, the outer perimeter of the adjustment head 54 may be configured in a hexagonal shape. In one or more other cases for example, the outer perimeter of the adjustment head 54 may be configured in a square shape, pentagonal shape, star shape, or the like. The adjustment head 54 may include a slot, similar to slot 53, for receiving or routing electronic connections as illustrated in FIGs. 13A and 13B.

[0095] In one or more cases, the external shape of the offset break-off head 55 may have the same external shape and size as the adjustment head 54. The external shape of the offset break-off head 55 may be offset with the external shape of the adjustment head 54. For example, for the cases in which the offset break-off head 55 and the adjustment head 54 have a hexagonal shape, the offset break-off head 55 may be offset from the adjustment head 54 by about 30° to 45°, and more preferably at or about 30°. By offsetting the offset break-off head 55 from the adjustment head 54, a tool, such as a hex-screw driver, may engage with the offset break-off head 55 and the distal end of the tool may rest on the top surface of the adjustment head 54. Moreover, by offsetting the offset break-off head 55 from the adjustment head 54, the tool may be prevented from engaging the offset break-off head 55 and the adjustment head 54 simultaneously. Additionally, for the cases in which the antenna 300 is positioned around the set screw, as in FIG. 4A, or positioned around the adjustment head 54, by offsetting the offset break-

off head 55 from the adjustment head 54, the tool may be prevented from contacting and/or damaging the antenna 300. In one or more cases, the length of the offset break-off head 55 may be greater than the length of the adjustment head 54. In one or more cases, the length of the offset break-off head 55 may have the same length as the length of the adjustment head 54. In one or more other cases, the perimeter of the external shape of the offset break-off head 55 may be larger than the perimeter of the adjustment head 54. In one or more other cases, the perimeter of the external shape of the offset break-off head 55 may be smaller than the perimeter of the adjustment head 54.

[0096] The break-off region 56 may be a scored portion of the driving feature 57b where the adjustment head 54 and the offset break-off head 55 are configured to separate. The driving feature 57b, and in particular, the break-off region 56, may be configured to withstand an amount of torque being applied to the driving feature 57b while engaging the longitudinal member 100 to the anchoring member 30 and fastening the set screw 50b to the anchoring member 30. The break-off region 56 may be configured to break when an amount of torque is applied to the offset break-off head 55, thereby separating the offset break-off head 55 from the adjustment head 54. For example, the break-off region 56 may be configured to break at or about 9 to 12 Newton meters (N m), and more preferably at or about 11 N m, of torque.

[0097] In one or more cases, the tool may fasten the set screw 50b to the anchoring member 30 by rotating the set screw 50b into the anchoring member 30. Having reached an amount of torque at the break-off region 56 configured to separate the offset break-off head 55 and the adjustment head 54, the offset break-off head 55 is broken off thereby separating the offset break-off head 55 from the adjustment head 54 at the break-off region 56 and leaving the adjustment head 54 fastened to the anchoring member 30. Subsequently, the tool may be engaged with the adjustment head 54 to further tighten and/or loosen the adjustment head 54 from the anchoring member 30.

[0098] In one or more cases, the set screws 50a and 50b may be implemented with antenna 300, integrated circuit 302, strain gauge 306, electronics component 304, connecting member 308, and their related features and components, as discussed with respect to FIGs. 3-5.

[0099] As used herein, the term “about” in reference to a numerical value means plus or minus 10% of the numerical value of the number with which it is being used.

[00100] The features and functions described above, as well as alternatives, may be combined into many other different systems or applications. Various alternatives, modifications, variations or improvements may be made by those skilled in the art, each of which is also intended to be encompassed by the disclosed embodiments.

## CLAIMS

What is claimed is:

1. A load sensing assembly for a spinal implant, the load sensing assembly comprising:
  - a break-off set screw comprising a break-off head coupled to an adjustment head via a break-off region, and a bore extending from an outer surface of the break-off head to a threaded portion of the break-off set screw;
  - an antenna;
  - an integrated circuit in communication with the antenna; and
  - a strain gauge in connection with the integrated circuit,wherein the integrated circuit and strain gauge are positioned within the bore of the set screw, and
  - wherein the threaded portion of the break-off set screw is configured to fasten to an anchoring member.
2. The load sensing assembly of claim 1, wherein the break-off region is configured to break at or about 9 to 12 Newton meters.
3. The load sensing assembly of claim 1, wherein an outer surface of the break-off head is aligned with an outer surface of the adjustment head.
4. The load sensing assembly of claim 1, wherein an outer surface of the break-off head is offset from an outer surface of the adjustment head.
5. The load sensing assembly of claim 4, wherein the outer surface of the break-off head is offset from the outer surface of the adjustment head by 30°.
6. The load sensing assembly of claim 1, wherein the adjustment head is configured to receive a tool to tighten the set screw into the anchoring member after the break-off head is separated from the adjustment head.

7. The load sensing assembly of claim 1, wherein the adjustment head is configured to receive a tool to loosen the set screw out of the anchoring member after the break-off head is separated from the adjustment head.
8. The load sensing assembly of claim 1, wherein an upper surface of the threaded portion is configured to be flush with or recessed within an end of the anchoring member when the adjustment head is fastened to the anchoring member.
9. The load sensing assembly of claim 1, wherein an upper surface of the adjustment head is configured to be flush with or recessed within an end of the anchoring member when the adjustment head is fastened to the anchoring member.
10. A load sensing assembly for a spinal implant, the load sensing assembly comprising:  
a break-off set screw comprising a break-off head coupled to an adjustment head via a break-off region, and a bore extending from an outer surface of the break-off head to a threaded portion of the break-off set screw;  
an antenna;  
an integrated circuit in communication with the antenna; and  
a strain gauge in connection with the integrated circuit,  
wherein the integrated circuit and strain gauge are positioned within the bore of the set screw,  
wherein the threaded portion of the break-off set screw is configured to fasten to an anchoring member, and  
wherein an outer surface of the break-off head is aligned with an outer surface of the adjustment head.
11. The load sensing assembly of claim 10, wherein the break-off region is configured to break at or about 9 to 12 Newton meters.

12. The load sensing assembly of claim 10, wherein an outer perimeter of the break-off head when viewed from a top view is a hexagonal shape.
13. The load sensing assembly of claim 10, wherein the adjustment head is configured to receive a tool to tighten the set screw into the anchoring member after the break-off head is separated from the adjustment head.
14. The load sensing assembly of claim 10, wherein the adjustment head is configured to receive a tool to loosen the set screw out of the anchoring member after the break-off head is separated from the adjustment head.
15. A load sensing assembly for a spinal implant, the load sensing assembly comprising:
  - a break-off set screw comprising a break-off head coupled to an adjustment head via a break-off region, and a bore extending from an outer surface of the break-off head to a threaded portion of the break-off set screw;
  - an antenna;
  - an integrated circuit in communication with the antenna; and
  - a strain gauge in connection with the integrated circuit,wherein the integrated circuit and strain gauge are positioned within the bore of the set screw,
  - wherein the threaded portion of the break-off set screw is configured to fasten to an anchoring member, and
  - wherein an outer surface of the break-off head is offset from an outer surface of the adjustment head.
16. The load sensing assembly of claim 15, wherein the break-off region is configured to break at or about 9 to 12 Newton meters.
17. The load sensing assembly of claim 15, wherein an outer perimeter of the break-off head when viewed from a top view is a hexagonal shape.

18. The load sensing assembly of claim 15, wherein the outer surface of the break-off head is offset from the outer surface of the adjustment head by 30°.

19. The load sensing assembly of claim 15, wherein the adjustment head is configured to receive a tool to tighten the set screw into the anchoring member after the break-off head is separated from the adjustment head.

20. The load sensing assembly of claim 15, wherein the adjustment head is configured to receive a tool to loosen the set screw out of the anchoring member after the break-off head is separated from the adjustment head.

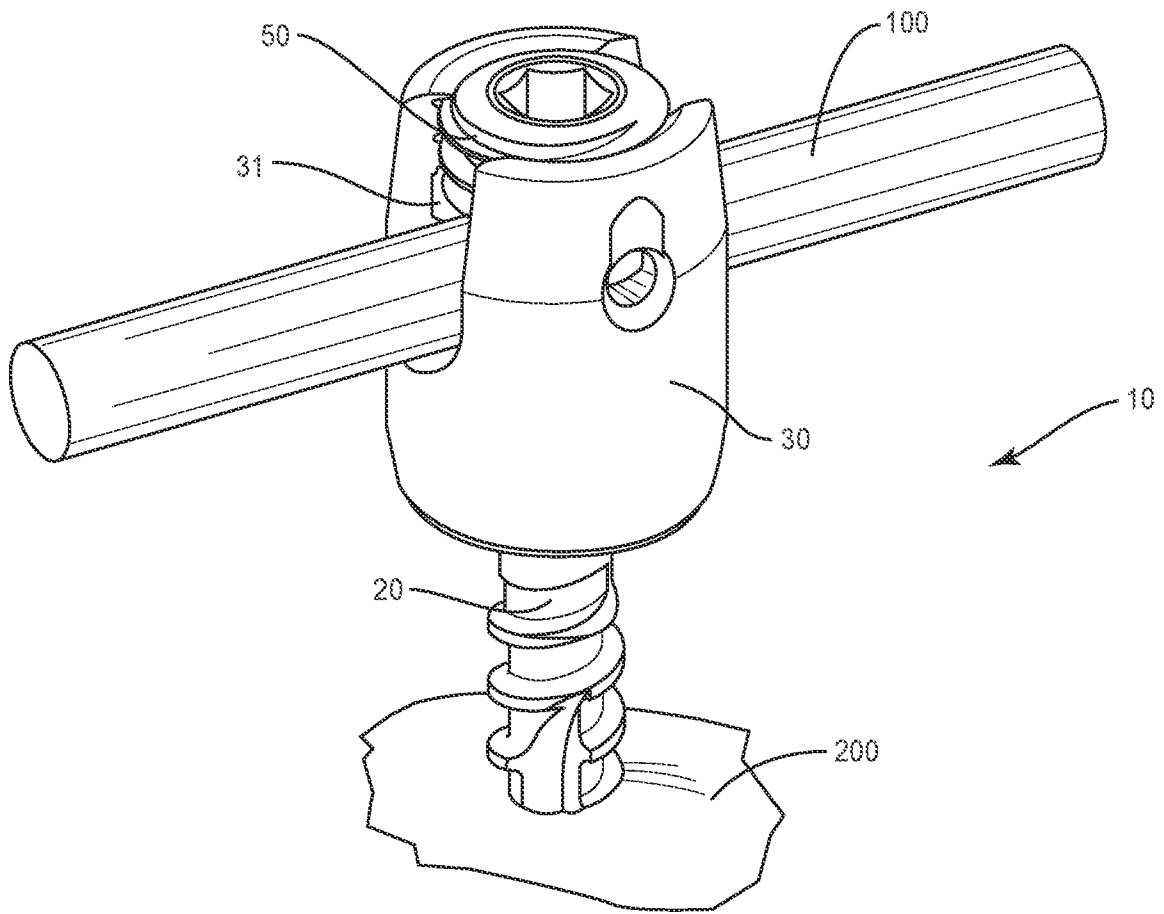

FIG. 1



2/16

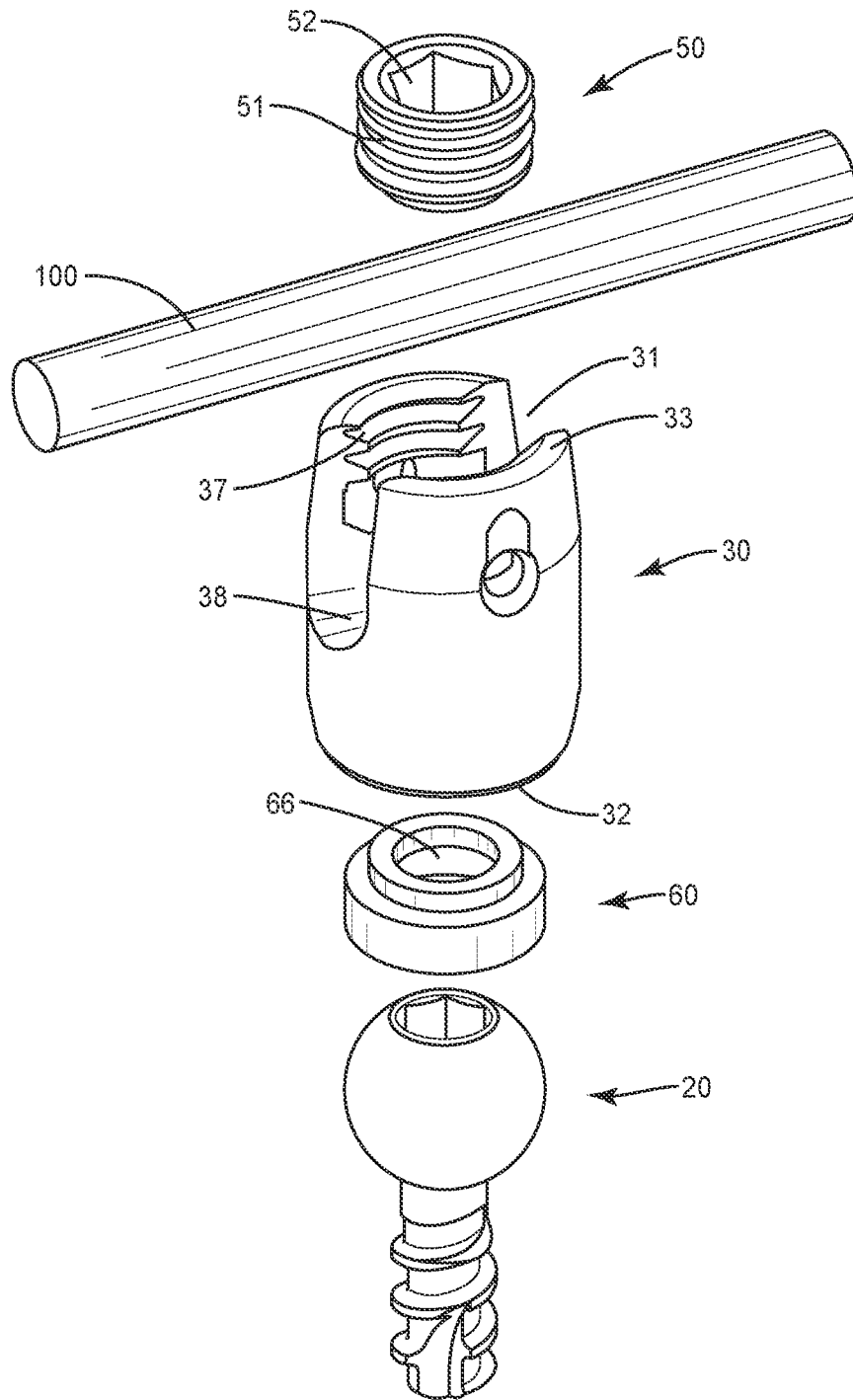
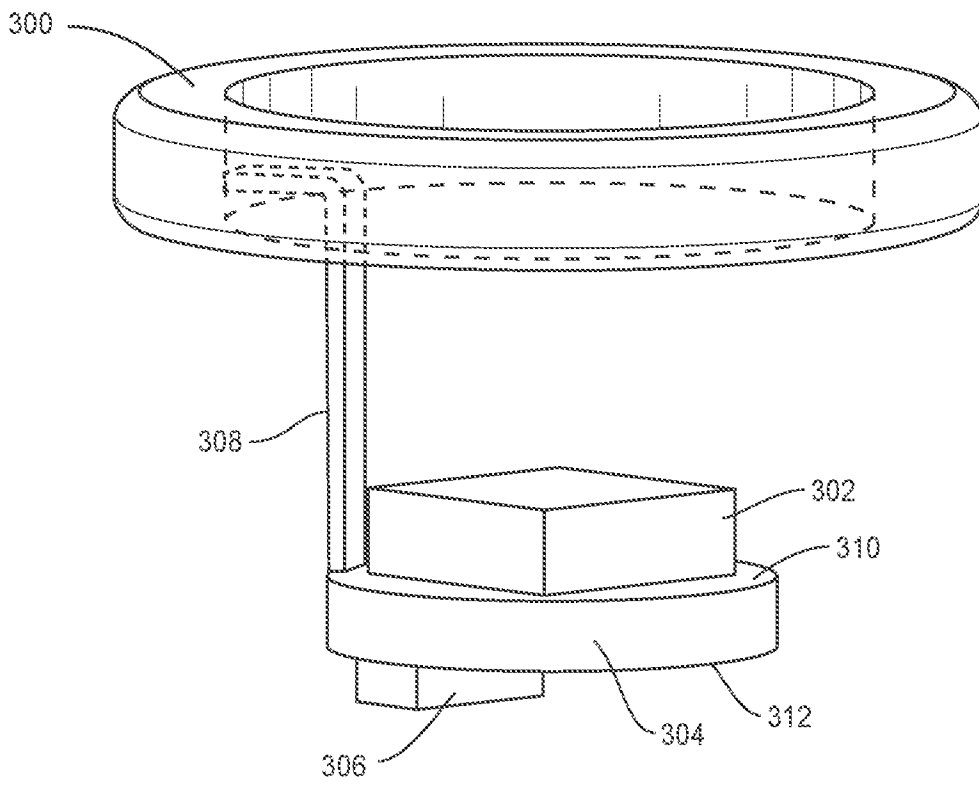

FIG. 2



**FIG. 3**

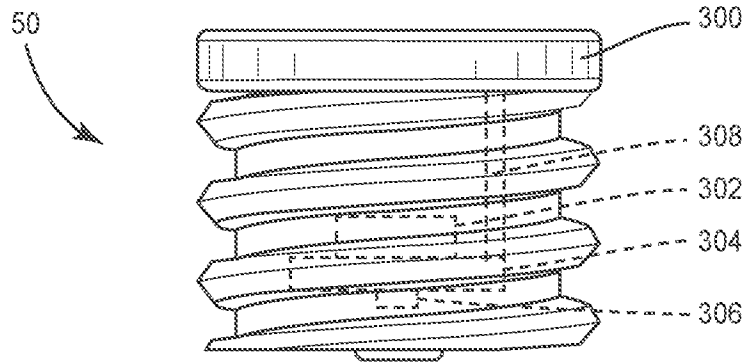

FIG. 4A

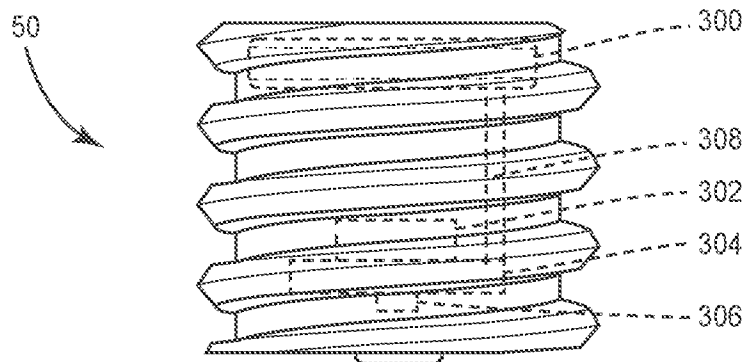

FIG. 4B

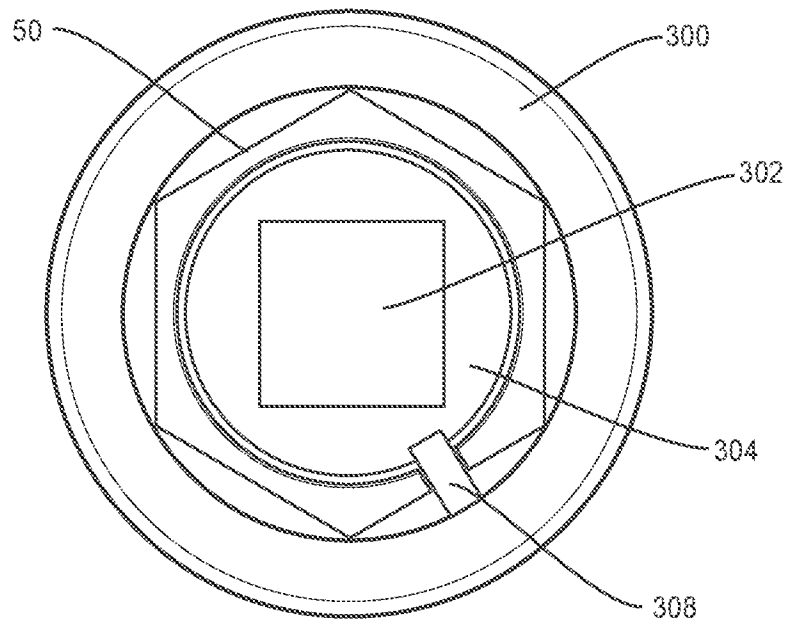

FIG. 5

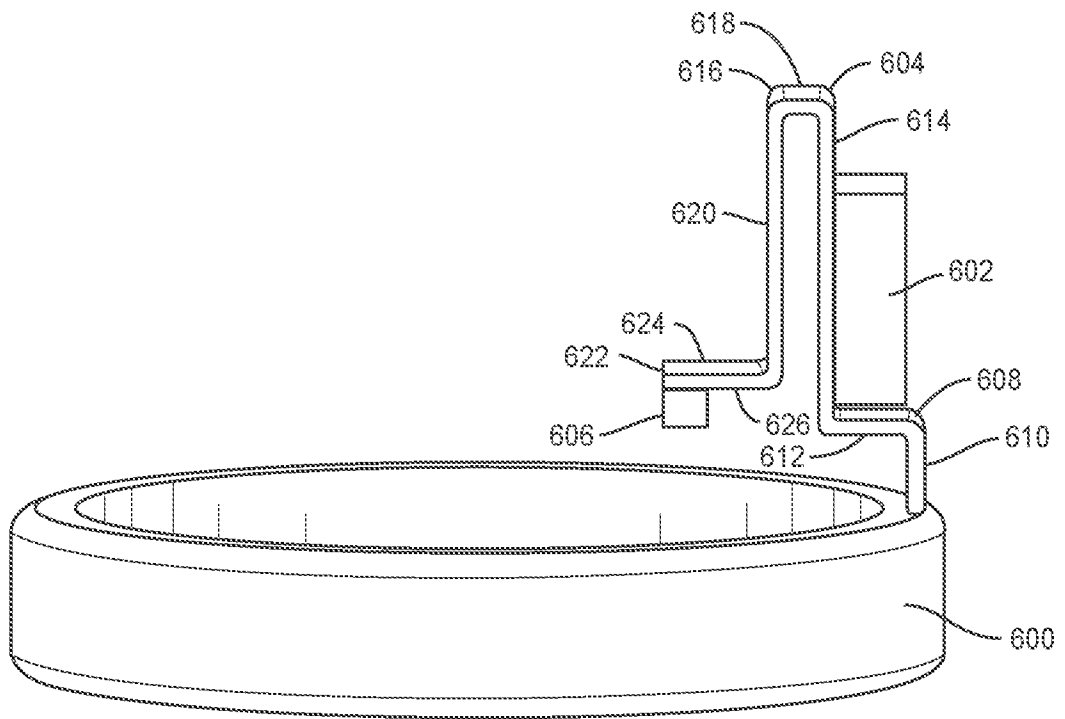
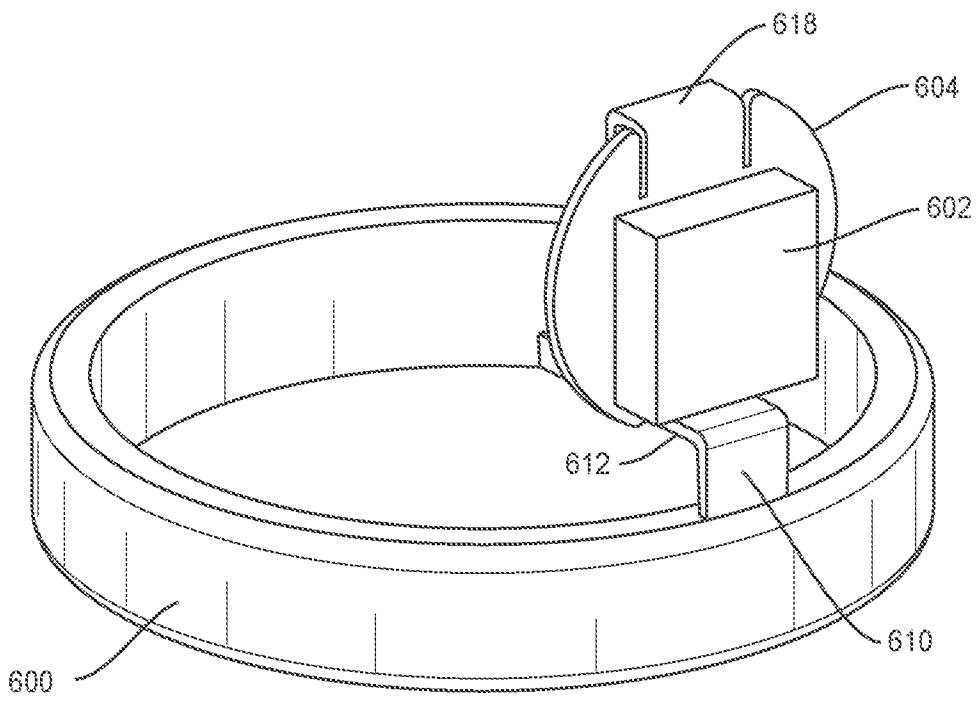

FIG. 6



**FIG. 7**

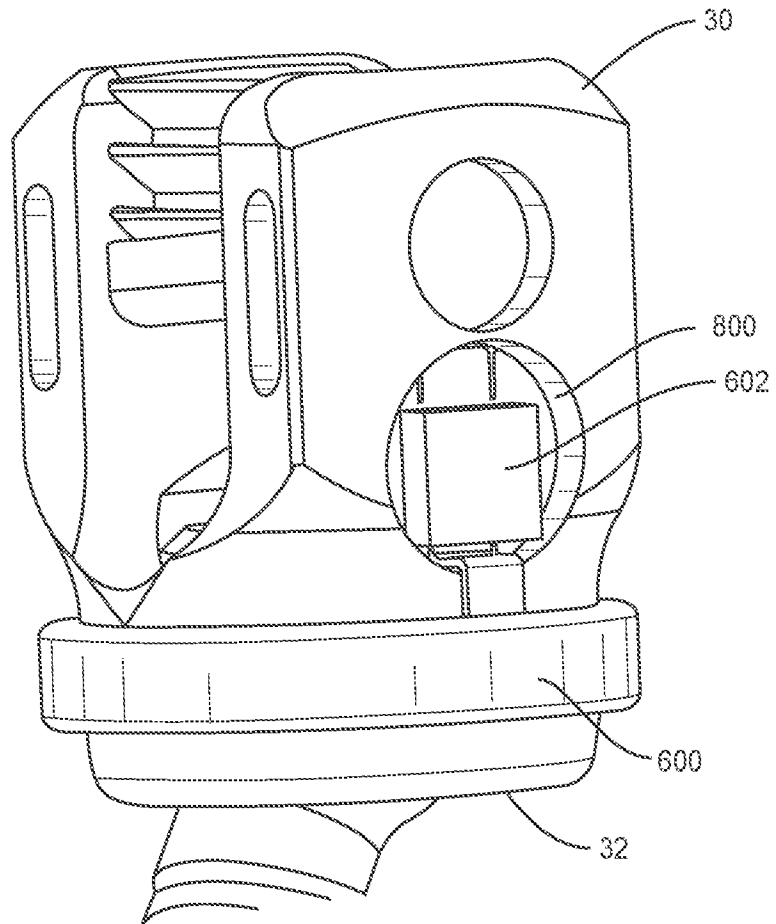

FIG. 8

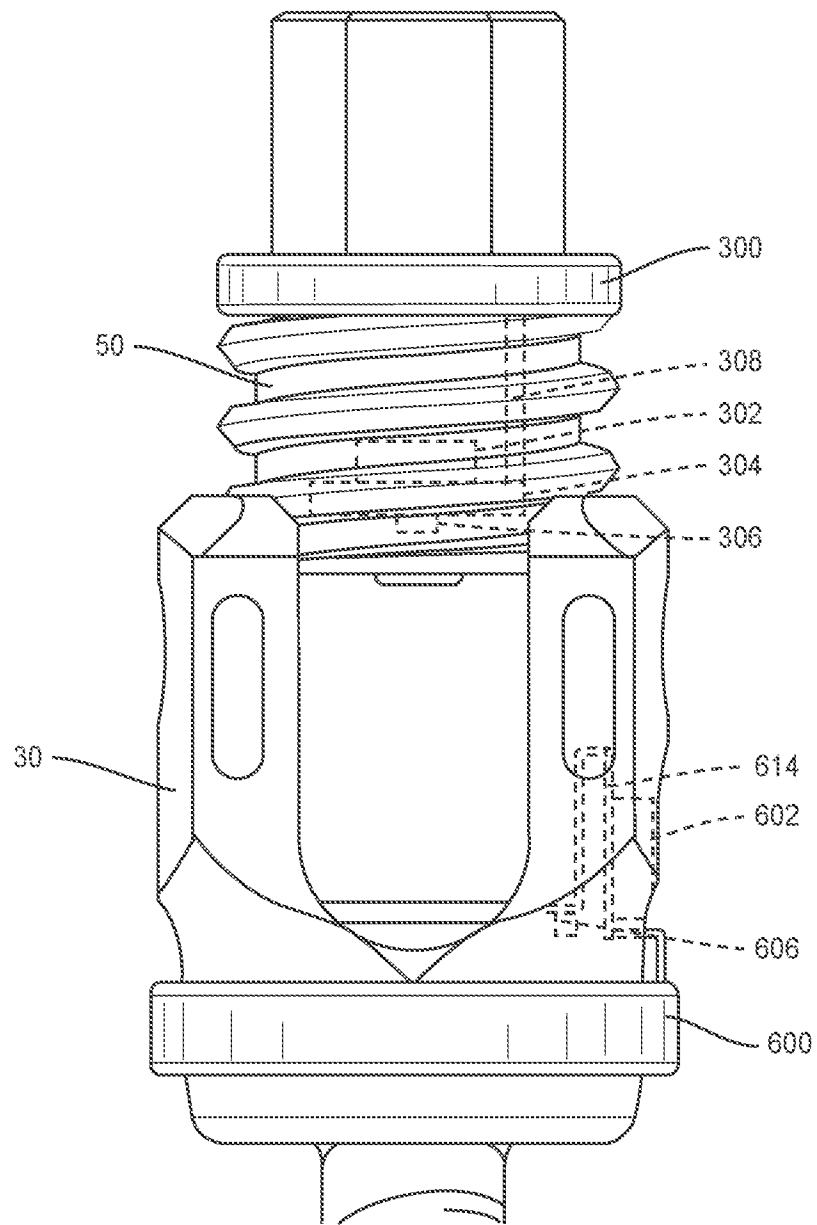

FIG. 9



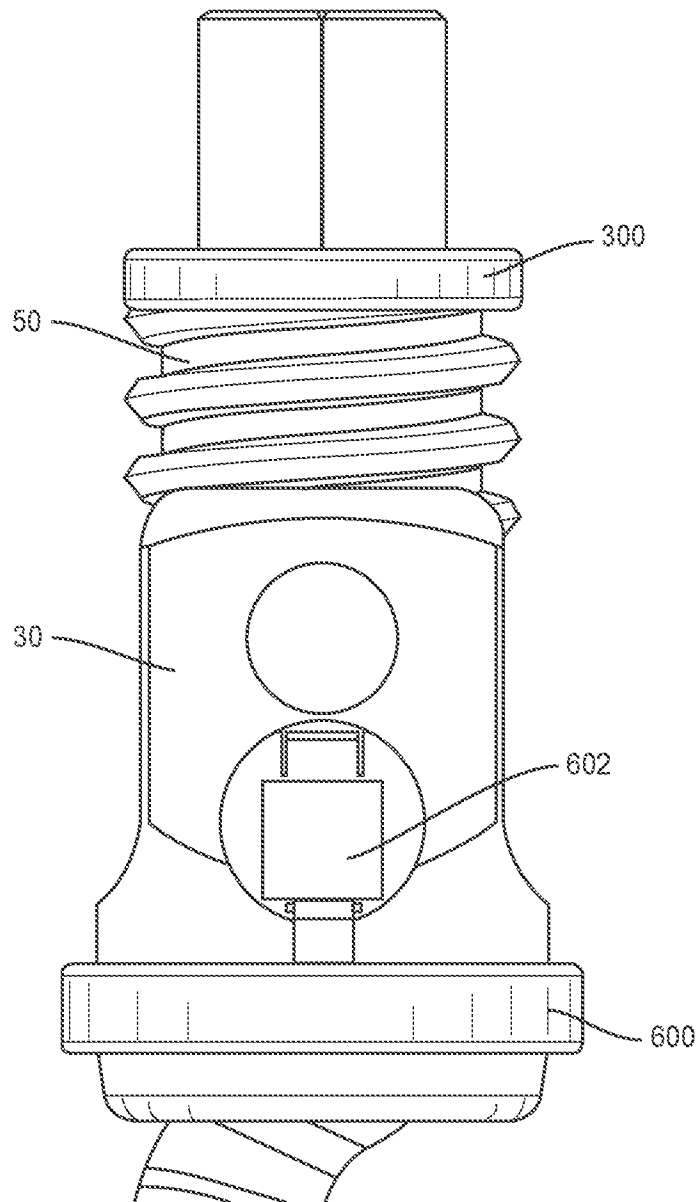

FIG. 10

11/16

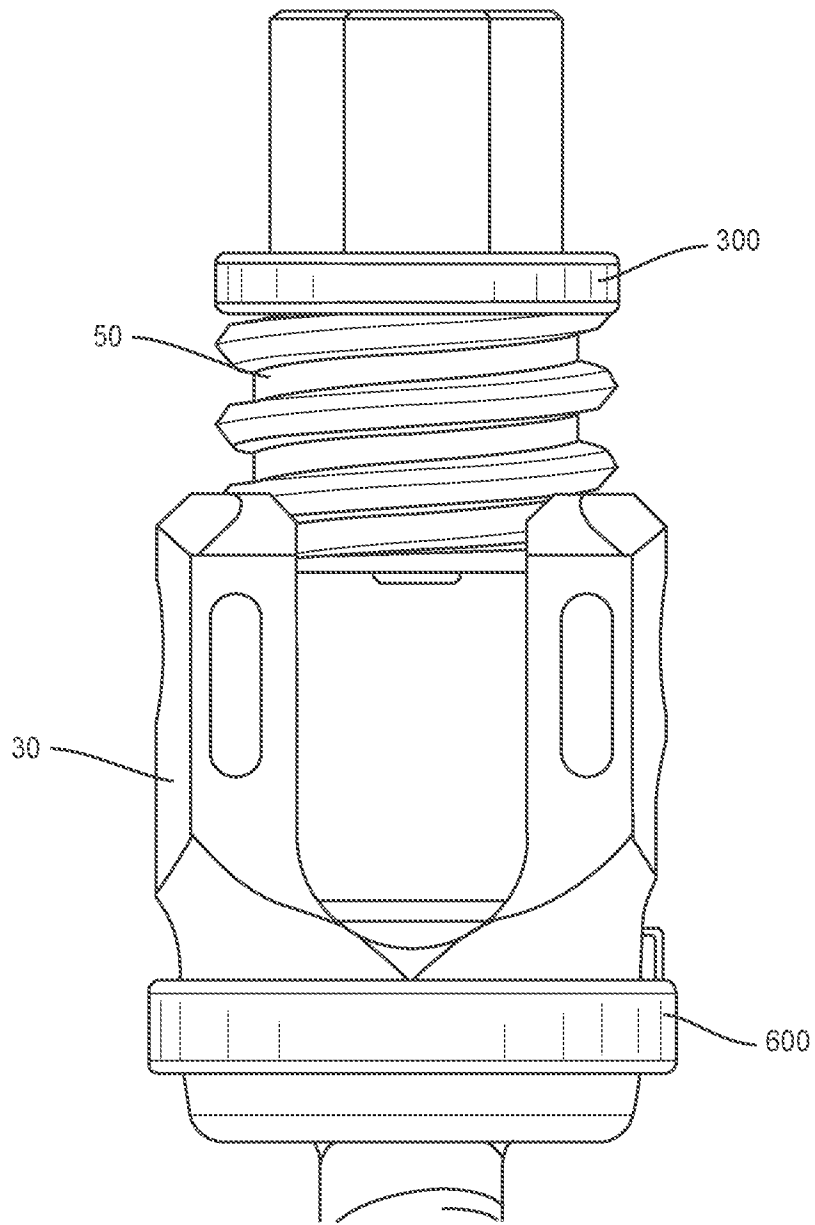

FIG. 11

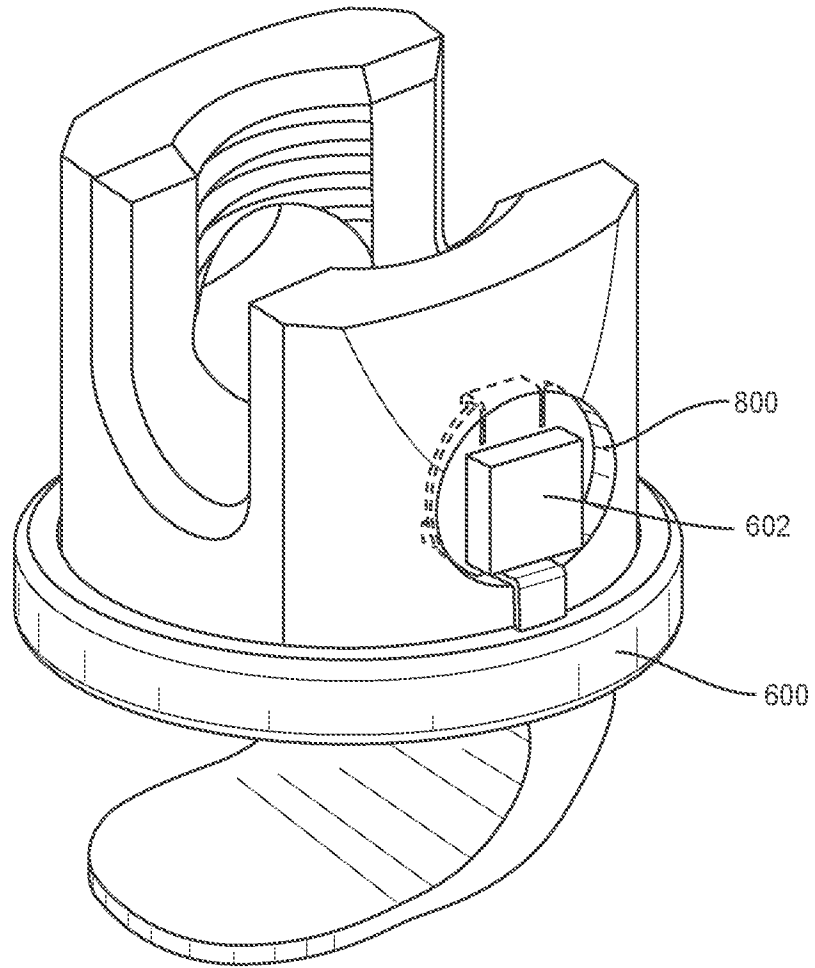

FIG. 12

13/16

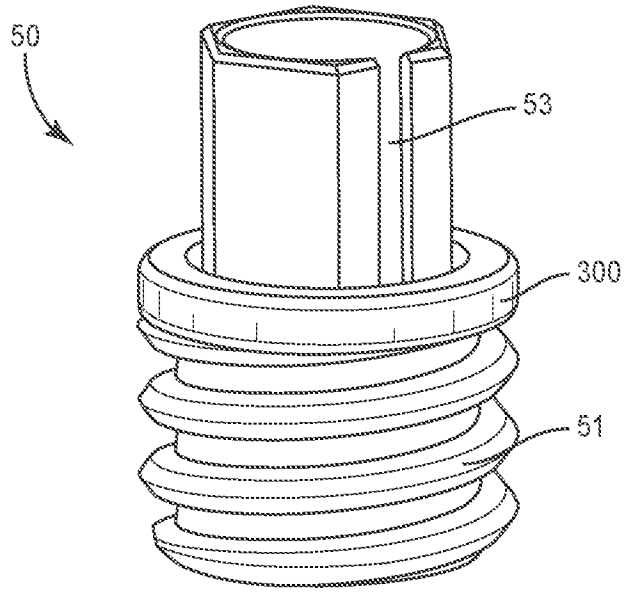

FIG. 13A

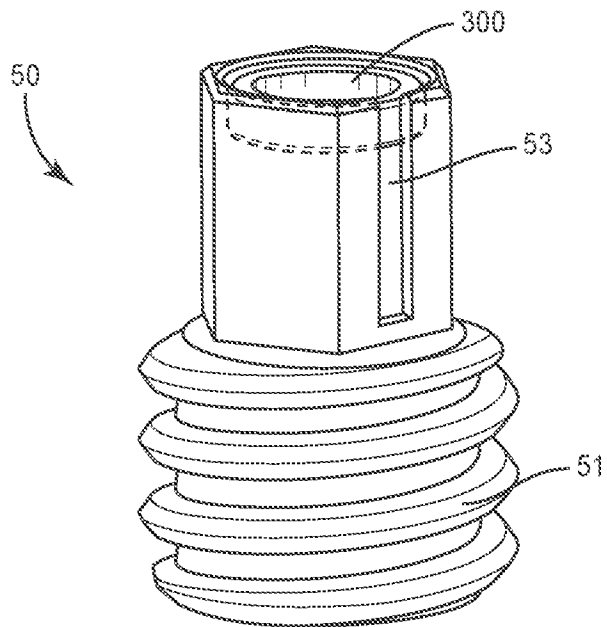

FIG. 13B

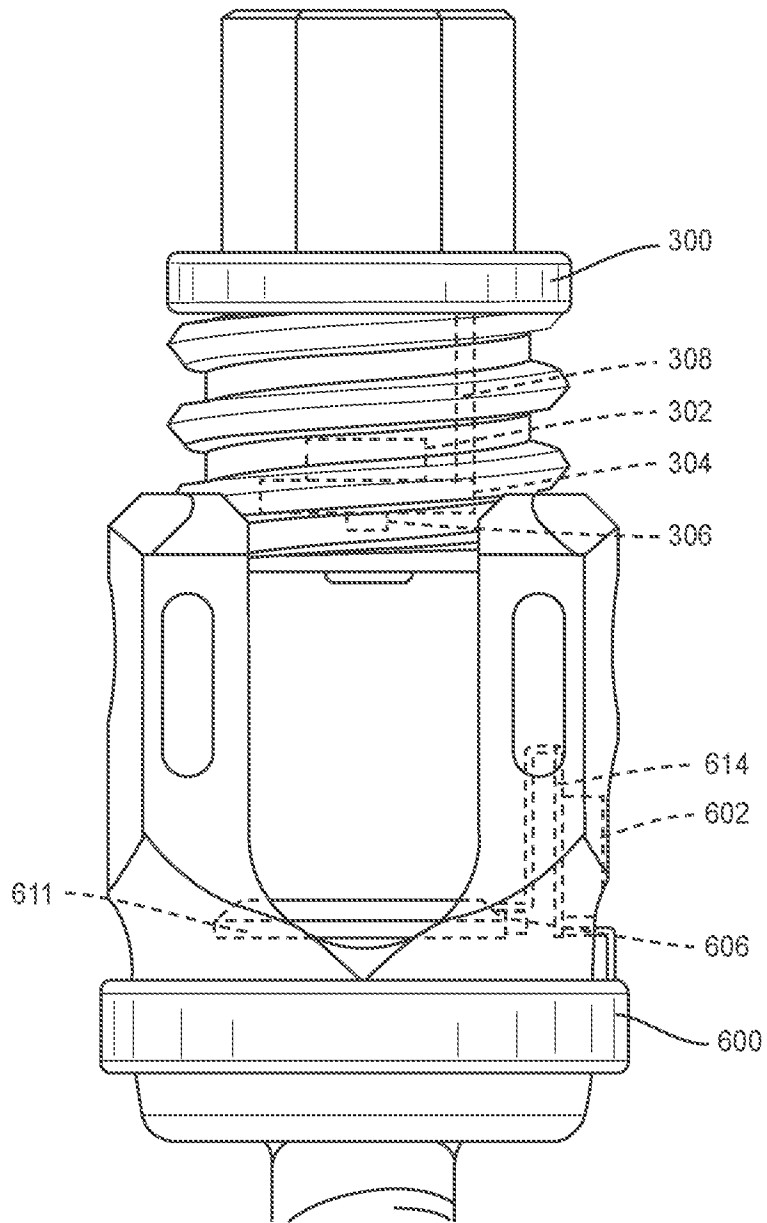

FIG. 14

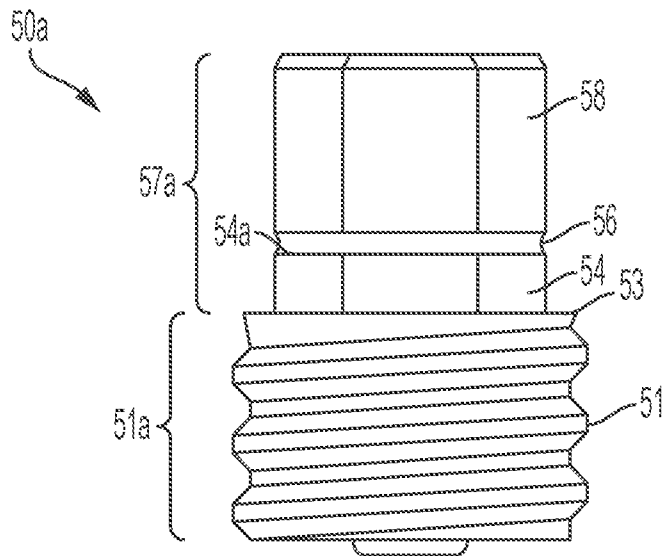

FIG. 15A

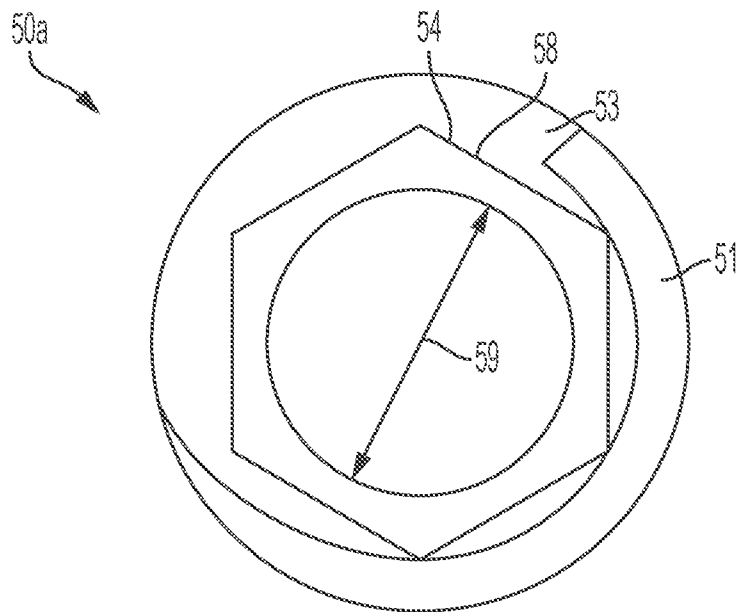

FIG. 15B

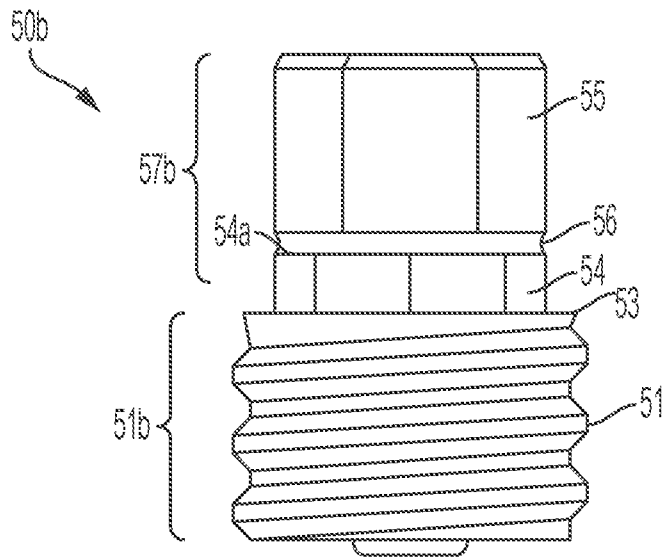

FIG. 16A

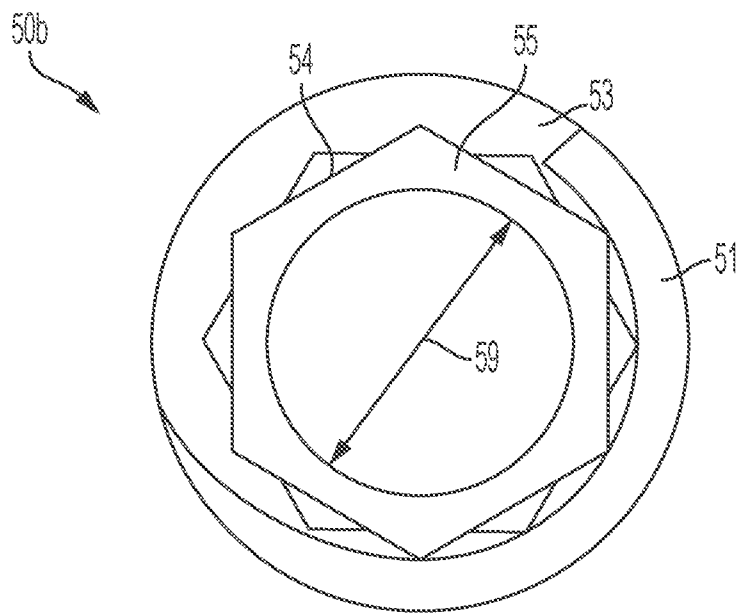

FIG. 16B

## INTERNATIONAL SEARCH REPORT

International application No.  
**PCT/US2019/042511****A. CLASSIFICATION OF SUBJECT MATTER****A61B 17/70(2006.01)i, A61F 2/46(2006.01)i, A61B 90/00(2016.01)i, H01Q 1/22(2006.01)i, H01Q 1/38(2006.01)i**

According to International Patent Classification (IPC) or to both national classification and IPC

**B. FIELDS SEARCHED**

Minimum documentation searched (classification system followed by classification symbols)

A61B 17/70; A61B 017/58; A61B 17/58; A61B 17/76; F16L 19/08; F16L 35/00; A61F 2/46; A61B 90/00; H01Q 1/22; H01Q 1/38

Documentation searched other than minimum documentation to the extent that such documents are included in the fields searched

Korean utility models and applications for utility models  
Japanese utility models and applications for utility models

Electronic data base consulted during the international search (name of data base and, where practicable, search terms used)

eKOMPASS(KIPO internal) &amp; Keywords: break-off, screw, load, sensor, spinal, head, antenna

**C. DOCUMENTS CONSIDERED TO BE RELEVANT**

Category*	Citation of document, with indication, where appropriate, of the relevant passages	Relevant to claim No.
Y	US 2005-0267477 A1 (JACKSON) 01 December 2005 See paragraphs [30],[32],[33], claim 12 and figures 1-6.	1-20
Y	US 2010-0201118 A1 (ANTON et al.) 12 August 2010 See paragraphs [61],[67],[105], claim 6 and figure 12.	1-20
A	US 6280445 B1 (MORRISON et al.) 28 August 2001 See the whole document.	1-20
A	WO 2015-200720 A2 (HUNTER, WILLIAM, L.) 30 December 2015 See the whole document.	1-20
A	US 2009-0234391 A1 (BUTLER et al.) 17 September 2009 See the whole document.	1-20

 Further documents are listed in the continuation of Box C. See patent family annex.

\* Special categories of cited documents:

"A" document defining the general state of the art which is not considered to be of particular relevance

"D" document cited by the applicant in the international application

"E" earlier application or patent but published on or after the international filing date

"L" document which may throw doubts on priority claim(s) or which is cited to establish the publication date of another citation or other special reason (as specified)

"O" document referring to an oral disclosure, use, exhibition or other means

"P" document published prior to the international filing date but later than the priority date claimed

"T" later document published after the international filing date or priority date and not in conflict with the application but cited to understand the principle or theory underlying the invention

"X" document of particular relevance; the claimed invention cannot be considered novel or cannot be considered to involve an inventive step when the document is taken alone

"Y" document of particular relevance; the claimed invention cannot be considered to involve an inventive step when the document is combined with one or more other such documents, such combination being obvious to a person skilled in the art

"&amp;" document member of the same patent family

Date of the actual completion of the international search

31 October 2019 (31.10.2019)

Date of mailing of the international search report

**31 October 2019 (31.10.2019)**

Name and mailing address of the ISA/KR

International Application Division  
Korean Intellectual Property Office  
189 Cheongsa-ro, Seo-gu, Daejeon, 35208, Republic of Korea

Facsimile No. +82-42-481-8578

Authorized officer

Kim, Yeonkyung

Telephone No. +82-42-481-3325





## INTERNATIONAL SEARCH REPORT

Information on patent family members

International application No.

**PCT/US2019/042511**

Patent document cited in search report	Publication date	Patent family member(s)	Publication date
US 2005-0267477 A1	01/12/2005	AU 2005-331062 A1	02/11/2006
		AU 2005-331062 B2	30/04/2009
		CA 2606128 A1	02/11/2006
		EP 1871246 A2	02/01/2008
		US 2005-0187549 A1	25/08/2005
		US 2006-0237813 A1	26/10/2006
		US 2006-0241602 A1	26/10/2006
		US 6884244 B1	26/04/2005
		US 7397102 B2	08/07/2008
		WO 2006-115539 A2	02/11/2006
		WO 2006-115539 A3	03/05/2007
		WO 2007-018861 A2	15/02/2007
		WO 2007-018861 A3	19/04/2007
		WO 2007-145674 A1	21/12/2007
		US 2010-0201118 A1	12/08/2010
DE 112008001699 T5	10/06/2010		
JP 2010-532452 A	07/10/2010		
JP 2013-242045 A	05/12/2013		
JP 2015-064109 A	09/04/2015		
JP 2016-128721 A	14/07/2016		
JP 2016-196962 A	24/11/2016		
JP 5854566 B2	09/02/2016		
JP 5938089 B2	22/06/2016		
JP 6006446 B2	12/10/2016		
US 10295093 B2	21/05/2019		
US 2010-0320755 A1	23/12/2010		
US 2013-0270814 A1	17/10/2013		
US 2015-0252922 A1	10/09/2015		
US 2016-0298796 A1	13/10/2016		
US 2019-0271419 A1	05/09/2019		
US 8439404 B2	14/05/2013		
US 9010810 B2	21/04/2015		
US 9400070 B2	26/07/2016		
WO 2009-003015 A1	31/12/2008		
WO 2009-003016 A1	31/12/2008		
US 6280445 B1	28/08/2001	AT 308931 T	15/11/2005
		AT 364356 T	15/07/2007
		AT 511386 T	15/06/2011
		AU 2000-42340 A1	02/11/2000
		AU 2000-42340 B2	27/11/2003
		AU 2001-247388 B2	21/07/2005
		AU 4234000 A	02/11/2000
		AU 4738801 A	24/09/2001
		AU 768045 B2	27/11/2003
		CA 2370056 A1	26/10/2000
		CA 2403057 A1	20/09/2001
		CA 2403057 C	28/11/2006

**INTERNATIONAL SEARCH REPORT**

Information on patent family members

International application No.

**PCT/US2019/042511**

Patent document cited in search report	Publication date	Patent family member(s)	Publication date
		DE 60023886 T2	03/08/2006
		DE 60128897 T2	07/02/2008
		EP 1187568 A2	20/03/2002
		EP 1187568 B1	09/11/2005
		EP 1272114 A1	08/01/2003
		EP 1272114 B1	13/06/2007
		EP 1656896 A2	17/05/2006
		EP 1656896 A3	29/11/2006
		EP 1656896 B1	01/06/2011
		ES 2251992 T3	16/05/2006
		ES 2287111 T3	16/12/2007
		JP 2002-541903 A	10/12/2002
		JP 2003-526444 A	09/09/2003
		JP 4276791 B2	10/06/2009
		JP 4327399 B2	09/09/2009
		US 2002-0026194 A1	28/02/2002
		US 2002-0029040 A1	07/03/2002
		US 2004-0158251 A1	12/08/2004
		US 6315779 B1	13/11/2001
		US 6689133 B2	10/02/2004
		US 6858031 B2	22/02/2005
		US 7252670 B2	07/08/2007
		WO 00-62692 A2	26/10/2000
		WO 00-62692 A3	15/02/2001
		WO 01-67974 A1	20/09/2001
WO 2015-200720 A2	30/12/2015	CA 2990821 A1	30/12/2015
		EP 3160369 A2	03/05/2017
		US 2017-0196508 A1	13/07/2017
		WO 2015-200720 A3	25/02/2016
US 2009-0234391 A1	17/09/2009	US 8221473 B2	17/07/2012
		WO 2009-114799 A1	17/09/2009