



(86) Date de dépôt PCT/PCT Filing Date: 2013/05/23
 (87) Date publication PCT/PCT Publication Date: 2013/11/28
 (85) Entrée phase nationale/National Entry: 2014/10/15
 (86) N° demande PCT/PCT Application No.: US 2013/042436
 (87) N° publication PCT/PCT Publication No.: 2013/177404
 (30) Priorités/Priorities: 2012/05/24 (US61/651,505);
 2012/09/18 (US13/622,299)

(51) Cl.Int./Int.Cl. *F41A 9/61* (2006.01),
F41A 9/72 (2006.01)
 (71) Demandeur/Applicant:
 TAURUS INTERNATIONAL MANUFACTURING, INC.,
 US
 (72) Inventeur/Inventor:
 MCPHERSON, MATHEW A., US
 (74) Agent: RIDOUT & MAYBEE LLP

(54) Titre : CHARGEUR DE PISTOLET A COURBURE LATERALE
 (54) Title: LATERALLY CURVED PISTOL MAGAZINE

FIG. 3

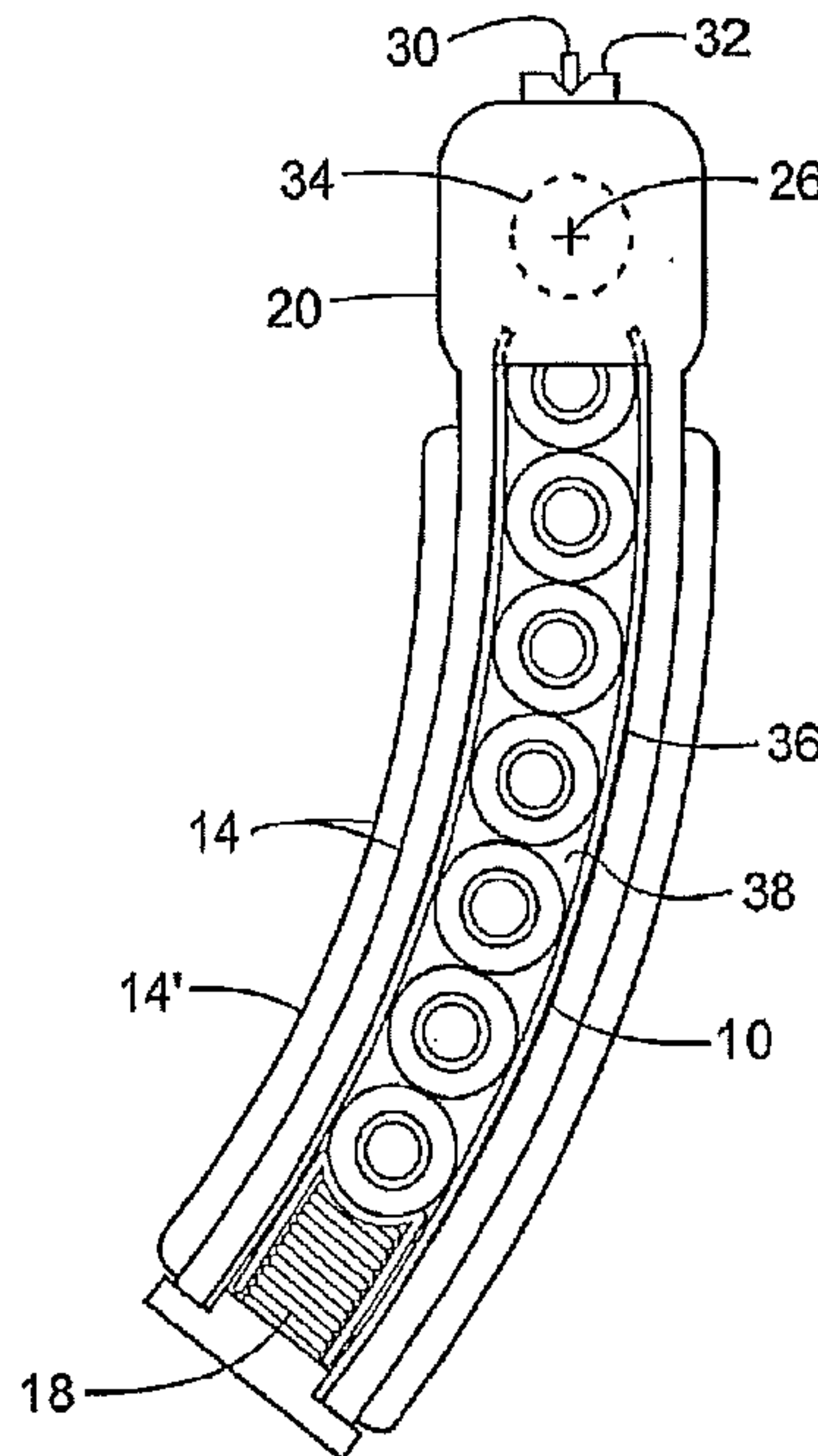

(57) **Abrégé/Abstract:**

Example cartridge magazines for use within a curved handle of certain pistols have a laterally curved housing so that the pistols and magazines can fit comfortably along a user's body. Such curved pistols and magazines are particularly suited for carrying within a shirt or pants pocket. A curved pistol loaded with a curved magazine, for instance, can be carried comfortably in one pocket while an extra loaded magazine can be carried in another pocket. Example magazines carry single and multiple rows of cartridges along appropriately sized curved housings. The magazine's curvature provides a user with a prominent tactile feature that quickly indicates in which direction the magazine should be inserted within the pistol.

(12) INTERNATIONAL APPLICATION PUBLISHED UNDER THE PATENT COOPERATION TREATY (PCT)

(19) World Intellectual Property
Organization
International Bureau(10) International Publication Number
WO 2013/177404 A1(43) International Publication Date
28 November 2013 (28.11.2013)

- (51) **International Patent Classification:**
F41A 9/61 (2006.01) *F41A 9/72* (2006.01)
- (21) **International Application Number:**
PCT/US2013/042436
- (22) **International Filing Date:**
23 May 2013 (23.05.2013)
- (25) **Filing Language:** English
- (26) **Publication Language:** English
- (30) **Priority Data:**
61/651,505 24 May 2012 (24.05.2012) US
13/622,299 18 September 2012 (18.09.2012) US
- (71) **Applicant:** TAURUS INTERNATIONAL MANUFACTURING, INC. [US/US]; 16175 NW 49th Avenue, Miami, FL 33014 (US).
- (72) **Inventor:** MCPHERSON, Mathew, A.; 19055 Incline Road, Norwalk, WI 54648 (US).
- (74) **Agents:** CURCIO, Robert et al.; Delio & Peterson, LLC, 700 State Street, Suite 402, New Haven, CT 06511 (US).
- (81) **Designated States** (*unless otherwise indicated, for every kind of national protection available*): AE, AG, AL, AM, AO, AT, AU, AZ, BA, BB, BG, BH, BN, BR, BW, BY, BZ, CA, CH, CL, CN, CO, CR, CU, CZ, DE, DK, DM, DO, DZ, EC, EE, EG, ES, FI, GB, GD, GE, GH, GM, GT, HN, HR, HU, ID, IL, IN, IS, JP, KE, KG, KM, KN, KP, KR, KZ, LA, LC, LK, LR, LS, LT, LU, LY, MA, MD, ME, MG, MK, MN, MW, MX, MY, MZ, NA, NG, NI, NO, NZ, OM, PA, PE, PG, PH, PL, PT, QA, RO, RS, RU, RW, SC, SD, SE, SG, SK, SL, SM, ST, SV, SY, TH, TJ, TM, TN, TR, TT, TZ, UA, UG, US, UZ, VC, VN, ZA, ZM, ZW.
- (84) **Designated States** (*unless otherwise indicated, for every kind of regional protection available*): ARIPO (BW, GH, GM, KE, LR, LS, MW, MZ, NA, RW, SD, SL, SZ, TZ, UG, ZM, ZW), Eurasian (AM, AZ, BY, KG, KZ, RU, TJ, TM), European (AL, AT, BE, BG, CH, CY, CZ, DE, DK, EE, ES, FI, FR, GB, GR, HR, HU, IE, IS, IT, LT, LU, LV, MC, MK, MT, NL, NO, PL, PT, RO, RS, SE, SI, SK, SM,

[Continued on next page]

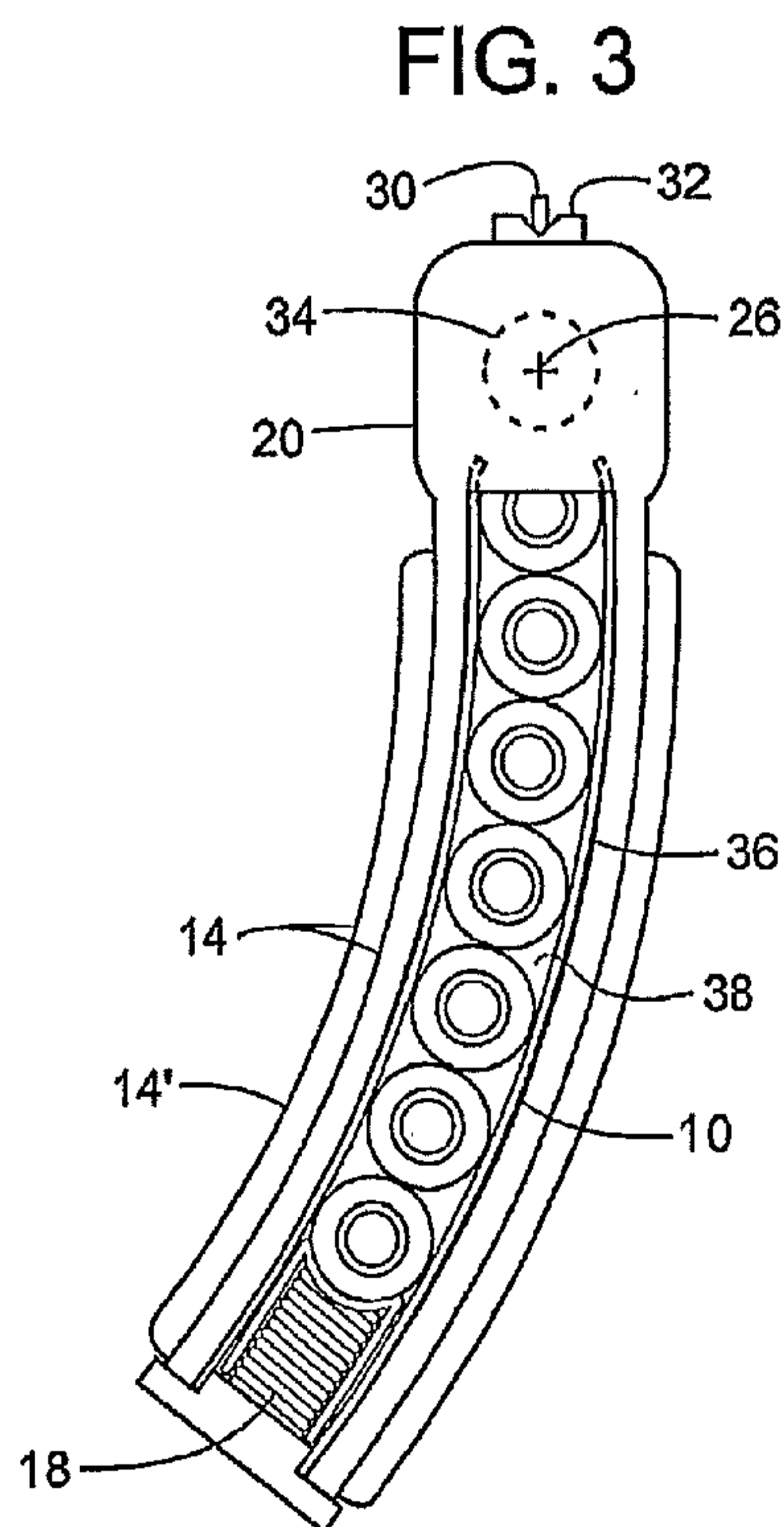
(54) **Title:** LATERALLY CURVED PISTOL MAGAZINE

(57) **Abstract:** Example cartridge magazines for use within a curved handle of certain pistols have a laterally curved housing so that the pistols and magazines can fit comfortably along a user's body. Such curved pistols and magazines are particularly suited for carrying within a shirt or pants pocket. A curved pistol loaded with a curved magazine, for instance, can be carried comfortably in one pocket while an extra loaded magazine can be carried in another pocket. Example magazines carry single and multiple rows of cartridges along appropriately sized curved housings. The magazine's curvature provides a user with a prominent tactile feature that quickly indicates in which direction the magazine should be inserted within the pistol.

WO 2013/177404 A1 

TR), OAPI (BF, BJ, CF, CG, CI, CM, GA, GN, GQ, GW,
ML, MR, NE, SN, TD, TG).

— *as to the applicant's entitlement to claim the priority of
the earlier application (Rule 4.17(iii))*

Declarations under Rule 4.17:

— *as to applicant's entitlement to apply for and be granted
a patent (Rule 4.17(ii))*

Published:

— *with international search report (Art. 21(3))*

LATERALLY CURVED PISTOL MAGAZINE

5

Cross Reference to Related Applications

This application claims the benefit of provisional patent application serial number
10 61/651,505 filed on May 24, 2012 and non-provisional patent application serial number
13/622,299 filed on September 18, 2012 by the present inventor.

Field of the Disclosure

15

The subject invention generally pertains to handguns and more specifically to
cartridge magazines for fitting within the handle of a pistol.

Background

20

Pistols and revolvers are examples of handguns. A cartridge is a combination of a
bullet and a shell, wherein the shell contains the gunpowder that upon ignition within the
firing chamber of a handgun propels the bullet as a projectile out through the barrel of the
25 handgun.

In the example of pistols, the firing chamber is generally integral with the barrel and
usually a linear magazine within the handle grip of the pistol sequentially feeds a series of
cartridges to the firing chamber. In the example of revolvers, a rotatable cylinder with a series
30 of circumferentially distributed firing chambers align sequentially a series of cartridges with
the revolver's barrel.

Brief Description of the Drawings

Figure 1 is a side view of a laterally curved magazine inserted within the handle of a pistol.

5 Figure 2 is a cross-sectional exploded view of the pistol shown in Figure 1.

Figure 3 is a cross-sectional view taken generally along line 3-3 of Figure 1.

Figure 4 is a cross-sectional view showing cartridges being inserted in the magazine of Figures 1-3.

Figure 5 is a side view of Figure 4.

10 Figure 6 is a cross-sectional view taken generally along line 6-6 of Figure 5.

Figure 7 is a side view similar to Figure 5 but showing the magazine loaded with cartridges.

Figure 8 is a cross-sectional view similar to Figure 3 but identifying certain geometric features.

15 Figure 9 is a cross-sectional view showing different positions of an example follower with an example magazine housing.

Figure 10 is a cross-sectional exploded view showing an example pistol magazine method.

20 Figure 11 is a cross-sectional view similar to Figure 4 but showing the bending and compressing of an example spring with a curved magazine.

Figure 12 is a top end view of the spring shown in Figures 10 and 11.

Figure 13 is a cross-sectional view similar to Figure 8 but showing an example magazine holding two rows of cartridges.

25

Detailed Description

Figures 1-13 illustrate example magazines 10 and 10' that are laterally curved for fitting within a similarly curved handle of a pistol 12 or other handgun. In the example illustrated in Figure 1, pistol 12 has a handle 14 shaped to fit comfortably against a user's body, thus pistol 12 can be readily carried under apparel or in a pants pocket.

Figures 2 and 3 show pistol 12 before and after installing magazine 10. Figures 4 and 5 show magazine 10 being loaded with cartridges 16. Figure 6 is a cross sectional view taken along lines 6-6 of Figure 5, and Figure 7 shows a lateral side view of magazine 10 when loaded. Figures 8 and 9 illustrate example geometric features and methods of magazine 10. Figures 10 and 11 illustrate an example method of assembling magazine 10. Figure 12 shows a top view of an example spring 18 used in some magazines. Figure 13 shows an example magazine 10' that is laterally curved for holding and conveying two rows of cartridges 16.

Referring to the example of Figures 1-3, pistol 12 comprises a frame 20, a barrel 22 with a bore 34 for shooting bullets in a forward direction 24 along the barrel's longitudinal centerline 26, a trigger 28, a front sight 30, a rear sight 32, laterally curved handle 14 being attached to or extending integrally from frame 20. In some examples, handle includes a grip 14'.

20

Referring further to Figures 4-7, magazine 10, in some examples, comprises a housing 36 defining an interior chamber 38 for storing and conveying cartridges 16. Some examples of housing 36 have a first side 36a, a second side 36b, a rear edge 36c, a forward edge 36d, an open end 40 and a blocked end 42. In some examples, an end cap 44 is attached to housing 36 at blocked end 42. Open end 40 is where cartridges 16 enter and leave magazine 10. In some examples, open end 40 includes some blockage or restraining feature 46 to help hold

cartridges 16 within magazine 10 until it is time for cartridge 16 to exit magazine 10. In some examples, sides 36a and 36b are wider than edges 36c and 36d. More specifically, as shown in Figure 6, a width 48 of sides 36a and 36b is greater than a width 50 of edges 36c and 36d.

5 Sides 36a and 36b, and edges 36c and 36d, extend between ends 40 and 42. The expression, "a side or edge extending between two ends" means at least a portion of the side or edge lies between the two ends but does not necessarily extend all the way to either end and is not necessarily entirely confined between the two ends. So, in some examples, a side extending between two ends also extends beyond one or both ends.

10

In some examples, first side 36a has a first contoured length 52 extending from blocked end 42 to open end 40. Second side 36b has a second contoured length 54 extending from blocked end 42 to open end 40. The term, "contoured length" (e.g., first length 52 and second length 54) means the length is measured along a surface rather than along a straight
15 line through space. For a hypothetical flat element, the element's contoured length equals its straight line length measured through space. For a hypothetical non-flat element, however, the element's contoured length is greater than its straight line length measured through space. In some examples, first contoured length 52 is longer than second contoured length 54, as shown in Figures 2, 4 and 9.

20

In some examples, first side 36a has a first interior surface 56 that is substantially concave along most of the first contoured length 52, and second side 54 has a second interior surface 58 facing toward first interior surface 56 and being substantially convex for most of the second contoured length 54. In other words, in some examples, a majority of first interior
25 surface 56 is concave, and a majority of second interior surface 58 is convex. In some examples, the first contoured length 52 is at a first radius of curvature 60, and the first

contoured length 52 with respect to a center point 62 of the first radius of curvature 60 extends between 0.3 and 1.2 radians (reference numeral 64).

The term, "substantially convex" not only pertains to curved surfaces but also encompasses polygonal surfaces with a plurality of flat surface segments that are distributed along a generally convex layout. Likewise, the term, "substantially concave" not only pertains to curved surfaces but also encompasses polygonal surfaces with a plurality of flat surface segments that are distributed along a generally concave layout.

Referring further to Figures 8 and 9, to push cartridges 16 along a contoured path 66 through chamber 38 toward open end 40, some examples of magazine 10 include spring 18 and a follower 68, wherein spring 18 is compressed lengthwise between follower 68 and end cap 44 or between follower 68 and some other blocking feature near blocked end 42. The term, "contoured path" means that path deviates from being perfectly linear from the beginning of the path to its end. Some examples of a contoured path include, but are not limited to, a nonlinear path, a circular segment, a plurality of non-collinear straight line segments joined end-to-end, non-circular curves, and various combinations thereof. In some examples, as shown in Figures 8 and 9, a longitudinal centerline 70 of contoured path 66 includes a substantially circular segment 72 having center of curvature 74 at point 62, wherein the substantially circular segment 72 extends between 0.3 and 1.2 radians (reference numeral 76) with respect to center of curvature 74.

In some examples, chamber 38 has a cross-section 78 (e.g., the chamber's cross-section as viewed across line 6-6 of Figure 5) perpendicular to path 66. Cross-section 78, in some examples, has a length 80 extending in forward direction 24 and a width 82 extending perpendicular to forward direction 24. Length 80 extends generally along the housing's first side 36a, width 82 extends between sides 36a and 36b, and length 80 is greater than width 82.

Figures 8 and 9 show follower 68 being movable along controlled path 66 between a fully loaded position 84 (e.g., Figs. 2, 3, 8 and 9) and an unloaded position 86 (e.g., Figs. 4, 9 and 11). In some examples, follower 68 has a side surface 88 that touches and slides along the housing's interior surfaces 56 and/or 58. Follower 68 in unloaded position 86 is proximate open end 40. Follower 68 in fully loaded position 84 is closer to blocked end 42 than to open end 40. As follower 68 travels along contoured path 66, the follower's travel direction changes from an initial travel direction 90 proximate blocked end 42 and a final travel direction 92 proximate open end 40. In the illustrated examples, contoured path 66 provides a limited variation 94 in travel direction between initial travel direction 90 and final travel direction 92. The term, "limited variation" means less than 360 degrees. In some examples, the limited variation 94 in travel direction is greater than zero degrees and less than 90 degrees.

In some examples, as shown in Figure 9, follower 68 relative to housing 36 has a first rotational orientation when follower is at fully loaded position 84, and follower 68 has a second rotational orientation when follower 68 is at unloaded position 86. The first rotational orientation and the second rotational orientation define therebetween a limited range of rotation 96 of follower 68 relative to housing 36. In the illustrated example, the limited range of rotation 96 is about a rotational axis 98 extending in forward direction 24, wherein the limited range of rotation 96 is greater than zero degrees and less than ninety degrees. The term, "axis 98 extending in forward direction 24" means that axis 98 is not perpendicular to forward direction 24 and does not necessarily mean that axis 98 is parallel to or collinear with forward direction 24. In some examples, axis 98 is substantially parallel to forward direction 24.

Arrow 66 shown in Figure 8 represents conveying the plurality of cartridges 16 along curved path 66 within handle 14 of pistol 12, wherein some examples of curved path 66 have a center axis of curvature that is non-perpendicular to the barrel's longitudinal centerline 26. It should be noted that perpendicular does not necessarily mean the lines intersect, as some lines are spaced apart non-intersecting perpendicular lines. Figures 3, 4 and 5 illustrate arranging the plurality of cartridges 16 in a single curved row within handle 14. Figure 13 illustrates arranging a plurality of cartridges 16 in a plurality of rows guided along a contoured path 66' through a curved handle 110 of a pistol 12', wherein path 66' curves about point 74'. Figure 13 also shows a spring 18' and a follower 68' for pushing cartridges 16 toward open end 40'.

In some examples, assembly of magazine 10 is as shown in Figures 10, 11 and 12. Figure 10 shows the assembly of various parts, Figure 11 shows spring 18 being compressed lengthwise and bent laterally, and Figure 12 shows a top end view of spring 18 prior to being bent within housing 36. Arrow 100 represents inserting follower 68 into housing 36. Arrow 102 represents inserting spring 18 into housing 36. Arrows 104 represent compressing spring 18 within housing 36 between follower 68 and blocked end 42. Arrows 105 represent bending spring 18 sideways against second side 36b of housing 36.

Spring 18, in some examples, has a longitudinal centerline 106 that is straighter prior to inserting spring 18 into housing 36. Note, longitudinal centerline 106 is shown straighter in Figure 10 than in Figure 11. Bending spring 18 laterally against side 36b of housing 36 helps prevent spring 18 from rattling around within housing 36. A pistol free of rattling noise is a benefit in some situations. In some examples, spring 18 comprises an elongate element 108 (e.g., a wire) helically disposed about longitudinal centerline 106.

Although the invention is described with respect to a preferred embodiment, modifications thereto will be apparent to those of ordinary skill in the art. The scope of the invention, therefore, is to be determined by reference to the following claims:

5

Claims:

1. A magazine for fitting within a handle of a pistol, the magazine comprising:
 - a housing having a first side, a second side, an open end and a blocked end, the housing defining a chamber flanked by the first side and the second side, the chamber providing a nonlinear path running between the open end and the blocked end, the chamber having a cross-section perpendicular to the nonlinear path, the cross-section having a length extending in a forward direction and a width extending perpendicular to the forward direction, the length extending along the first side, the width extending between the first side and the second side, the length being greater than the width;
 - a follower disposed within the chamber, the follower being movable along the nonlinear path between a fully loaded position and an unloaded position, the follower in the unloaded position being proximate the open end, the follower in the fully loaded position being closer to the blocked end than to the open end, the follower relative to the housing having a first rotational orientation when the follower is at the fully loaded position, the follower relative to the housing having a second rotational orientation when the follower is at the unloaded position, the first rotational orientation and the second rotational orientation defining therebetween a limited range of rotation of the follower relative to the housing, the limited range of rotation being about a rotational axis extending in the forward direction, the limited range of rotation being greater than zero degrees and less than ninety degrees; and

a spring disposed within the chamber and being compressed between the follower and the blocked end of the housing, the spring urging the follower along the nonlinear path toward the open end of the housing.

2. The magazine of claim 1, wherein the first side has a first interior surface, the second side has a second interior surface facing toward the first interior surface, the side surface of the follower touches the first interior surface, a majority of the first interior surface is concave, and a majority of the second interior surface is convex.
3. The magazine of claim 2, wherein the majority of the first interior surface that is concave has a first contoured length at a first radius of curvature, and the first contoured length with respect to a center point of the first radius of curvature extends between 0.3 and 1.2 radians.
4. The magazine of claim 1, wherein the first side has a first contoured length extending from the open end to the blocked end, the second side has a second contoured length extending from the open end to the blocked end, the first contoured length is longer than the second contoured length.
5. The magazine of claim 1, wherein a longitudinal centerline of the nonlinear path includes a substantially circular segment having a center of curvature, wherein the substantially circular segment extends between 0.3 and 1.2 radians with respect to the center of curvature.
6. A magazine for fitting within a handle of a pistol, the magazine comprising:
a housing having a first side, a second side, a rear edge, a forward edge, an open end and a blocked end, the first side and the second side being wider than the forward edge and the rear edge, each of the first side, the second side, the rear edge and the

forward edge extending between the open end and the blocked end, the first side having a first contoured length extending from the blocked end to the open end, the first side having a first interior surface that is substantially concave along most of the first contoured length, the second side having a second contoured length extending from the blocked end to the open end, the second side having a second interior surface facing toward the first interior surface and being substantially convex for most of the second contoured length;

a follower disposed within a chamber defined by the housing, the follower being movable along a contoured path between a fully loaded position and an unloaded position, the follower in the unloaded position being proximate the open end, the follower in the fully loaded position being closer to the blocked end than to the open end, the contoured path defining an initial travel direction proximate the blocked end, the contoured path defining a final travel direction proximate the open end, the contoured path providing a limited variation in travel direction between the initial travel direction and the final travel direction, the limited variation in travel direction being greater than zero degrees and less than 90 degrees; and

a spring disposed within the chamber and being compressed between the follower and the blocked end of the housing, the spring urging the follower along the contoured path toward the open end of the housing.

7. The magazine of claim 6, wherein a majority of the first interior surface is concave, and a majority of the second interior surface is convex.

8. The magazine of claim 7, wherein the majority of the first interior surface that is concave has a first contoured length at a first radius of curvature, and the first contoured

length with respect to a center point of the first radius of curvature extends between 0.3 and 1.2 radians.

9. The magazine of claim 6, wherein the first side has a first contoured length extending from the open end to the blocked end, the second side has a second contoured length extending from the open end to the blocked end, the first contoured length is longer than the second contoured length.

10. The magazine of claim 6, wherein a longitudinal centerline of the contoured path includes a substantially circular segment having a center of curvature, wherein the substantially circular segment extends between 0.3 and 1.2 radians with respect to the center of curvature.

11. A pistol magazine method involving the use of a pistol and a plurality of cartridges, wherein the pistol includes a handle for holding the pistol and a barrel for expelling a bullet, the pistol magazine method comprising:

conveying the plurality of cartridges along a curved path within the handle of the pistol, wherein the curved path has a center axis of curvature that is nonperpendicular to a longitudinal centerline of the barrel.

12. The pistol magazine method of claim 11, wherein the center axis of curvature is substantially parallel to the longitudinal centerline of the barrel.

13. The pistol magazine method of claim 12, further comprising arranging the plurality of cartridges in a single curved row within the handle.

14. The pistol magazine method of claim 13, further comprising arranging the plurality of cartridges in a plurality of rows within the handle.

15. The pistol magazine method of claim 11, wherein most of the curved path is substantially circular.

16. A pistol magazine method involving the use of a housing, a spring and a follower, wherein the housing has a first side, a second side, a blocked end and an open end, the first side and the second side being spaced apart to define a thickness of the housing, the first side has a length and a width, wherein the width is greater than the thickness and less than the length, the pistol magazine method comprising:

inserting the follower into the housing;

inserting the spring into the housing;

compressing the spring within the housing between the follower and the blocked end;

and

bending the spring against the second side.

17. The pistol magazine method of claim 16, wherein the spring has a longitudinal centerline that is straighter prior to inserting the spring into the housing.

18. The pistol magazine method of claim 17, wherein the spring comprises an elongate element helically disposed about the longitudinal centerline.

19. The pistol magazine method of claim 16, wherein the first side has a first interior surface, the second side has a second interior surface facing toward the first interior surface, a majority of the first interior surface is concave, and a majority of the second interior surface is convex.

20. The pistol magazine method of claim 19, the majority of the first interior surface is circular, and the majority of the second interior surface is circular.

FIG. 1

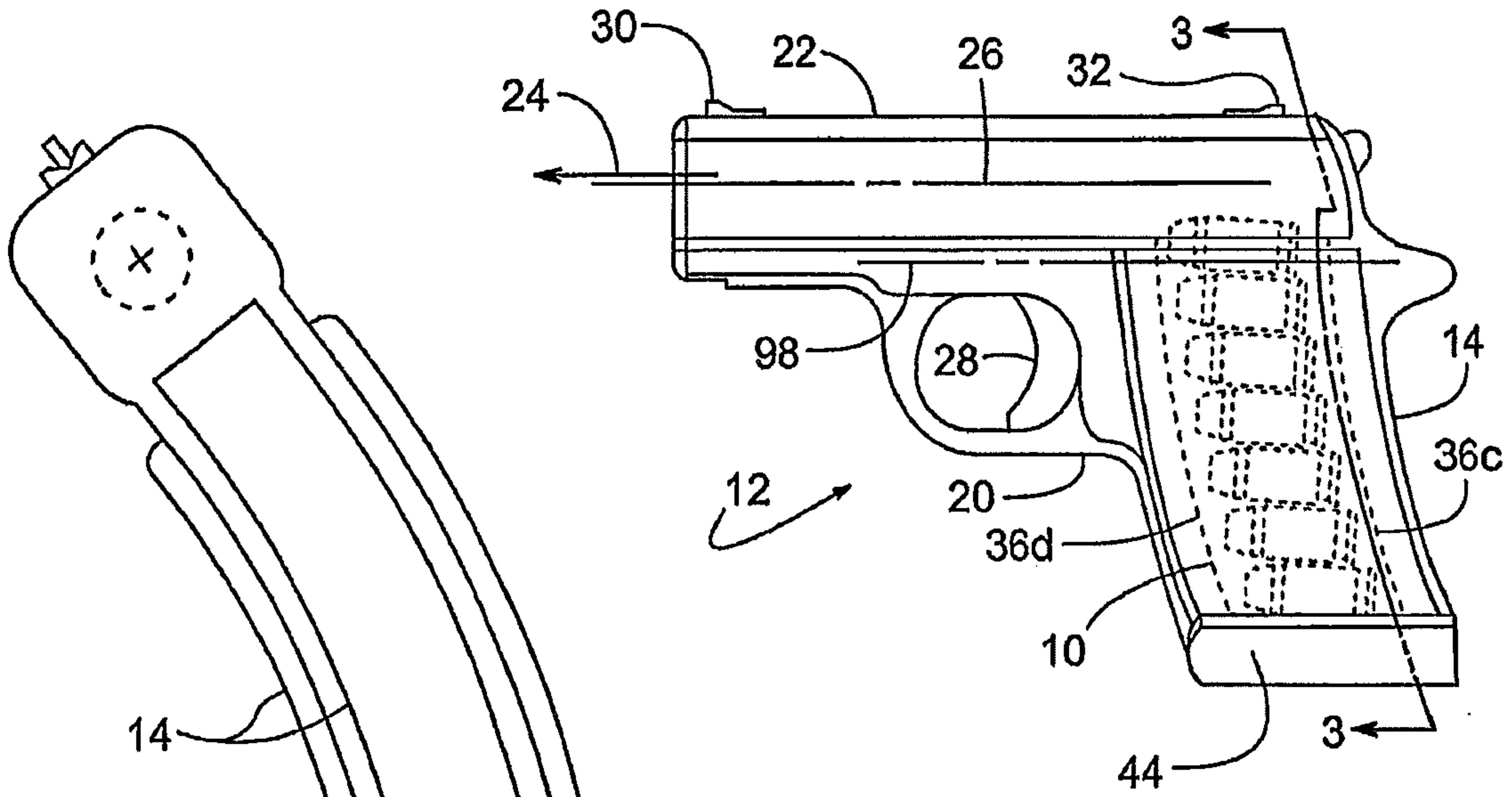

FIG. 2

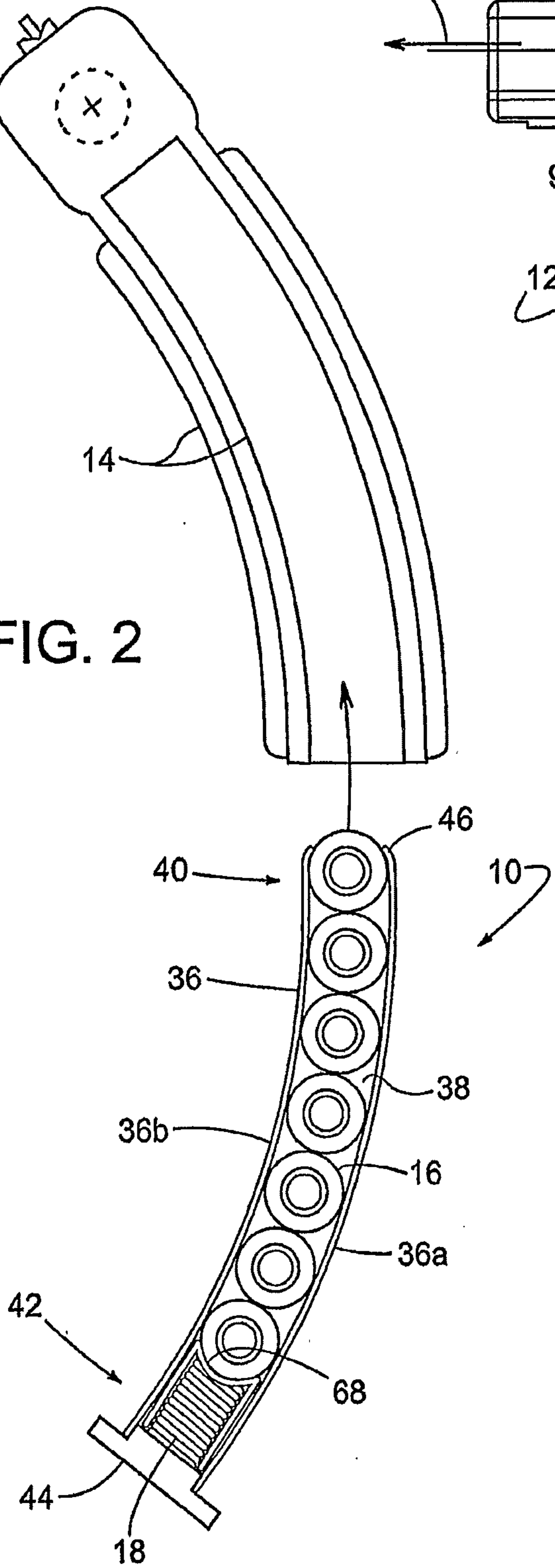

FIG. 3

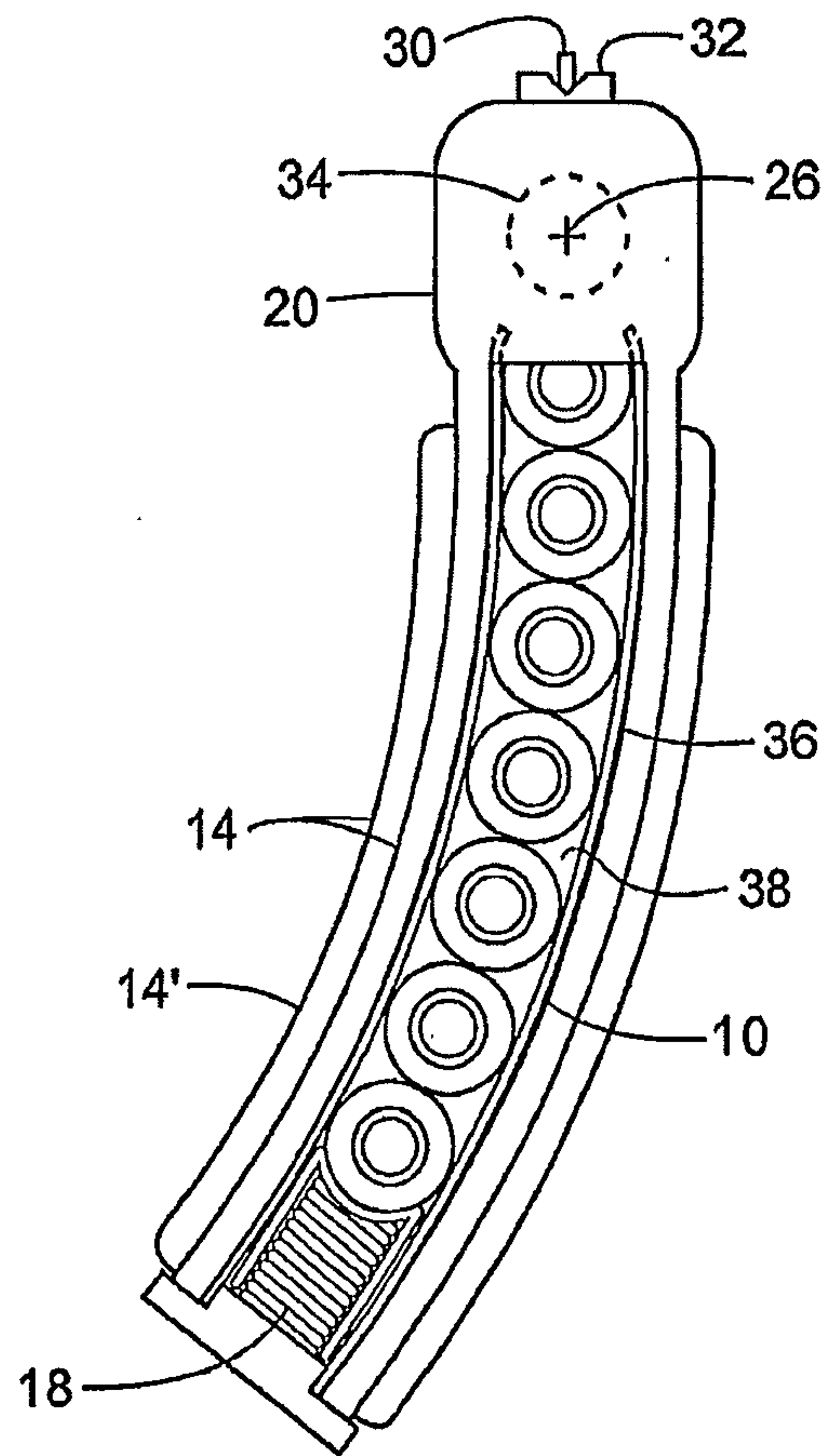

FIG. 5

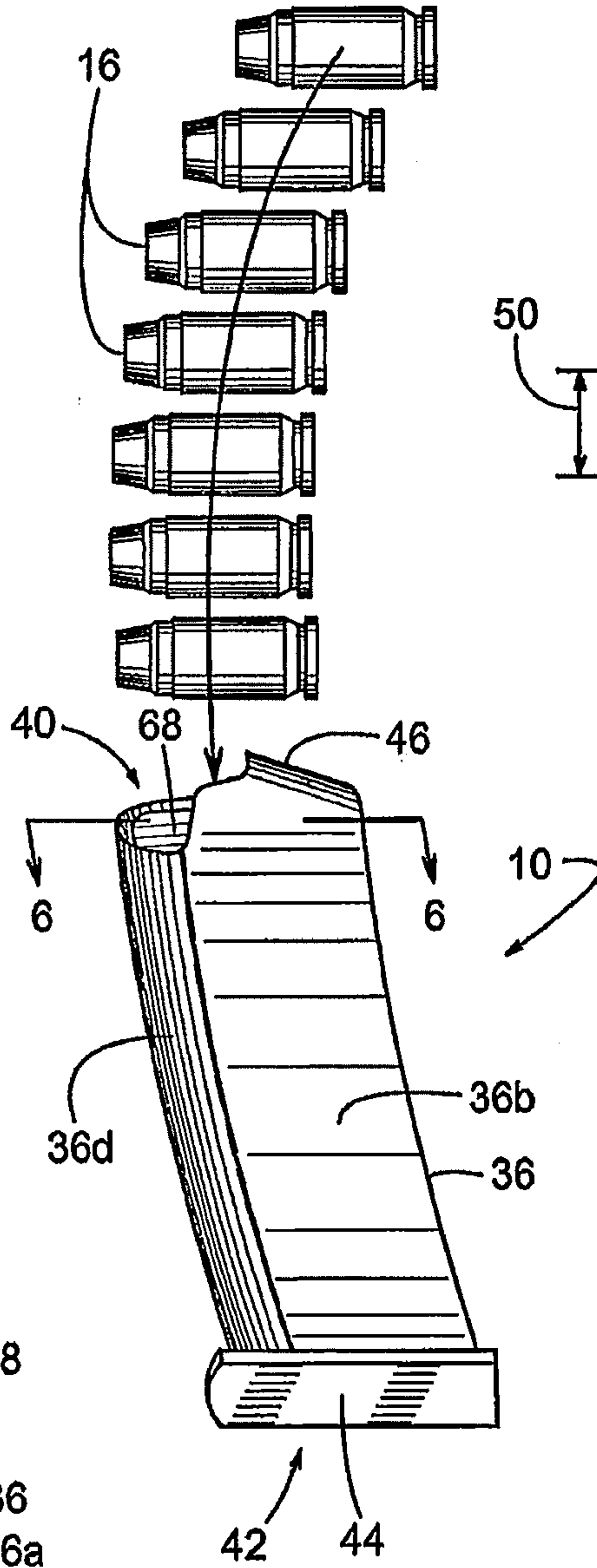

FIG. 6

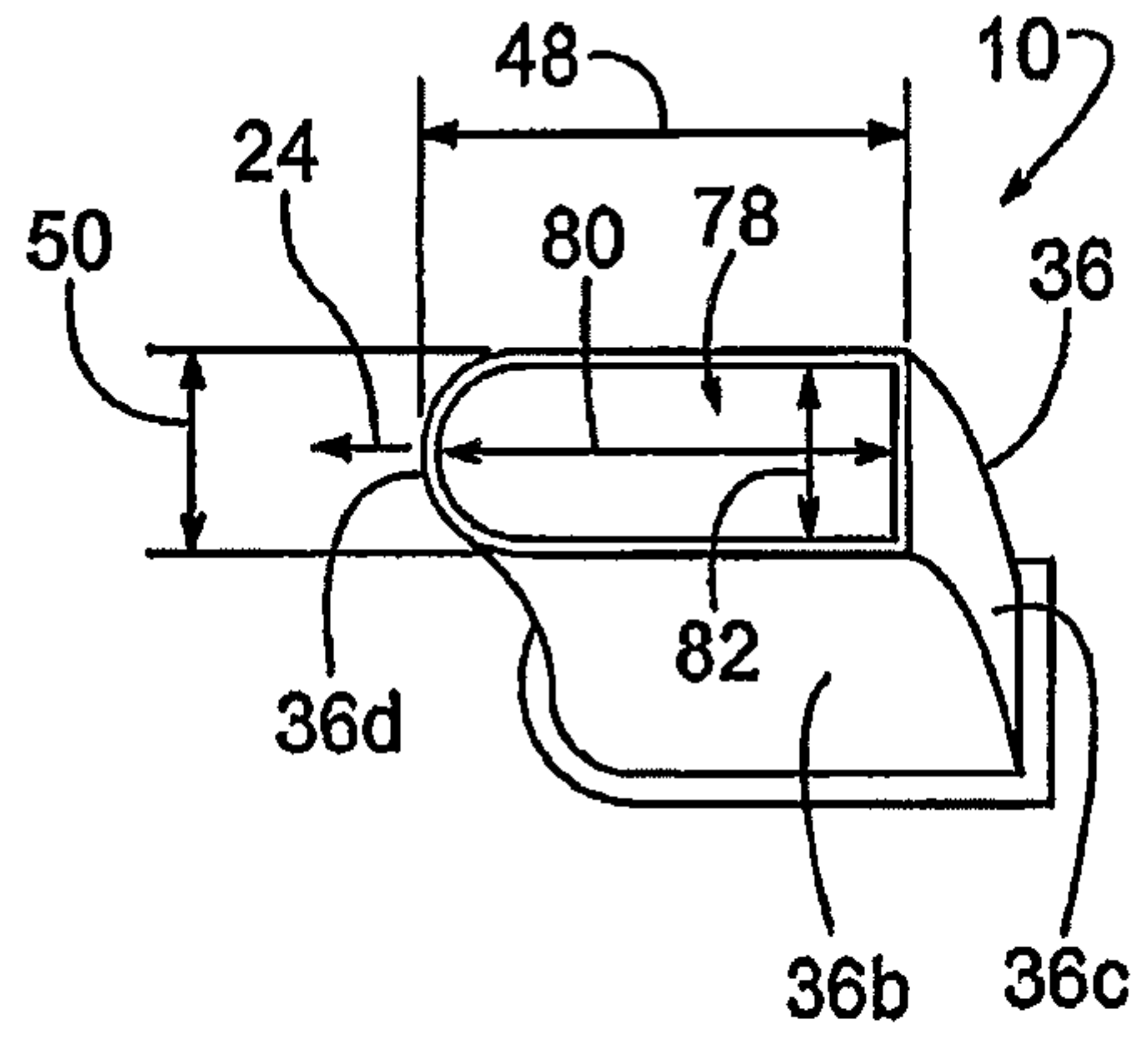

FIG. 4

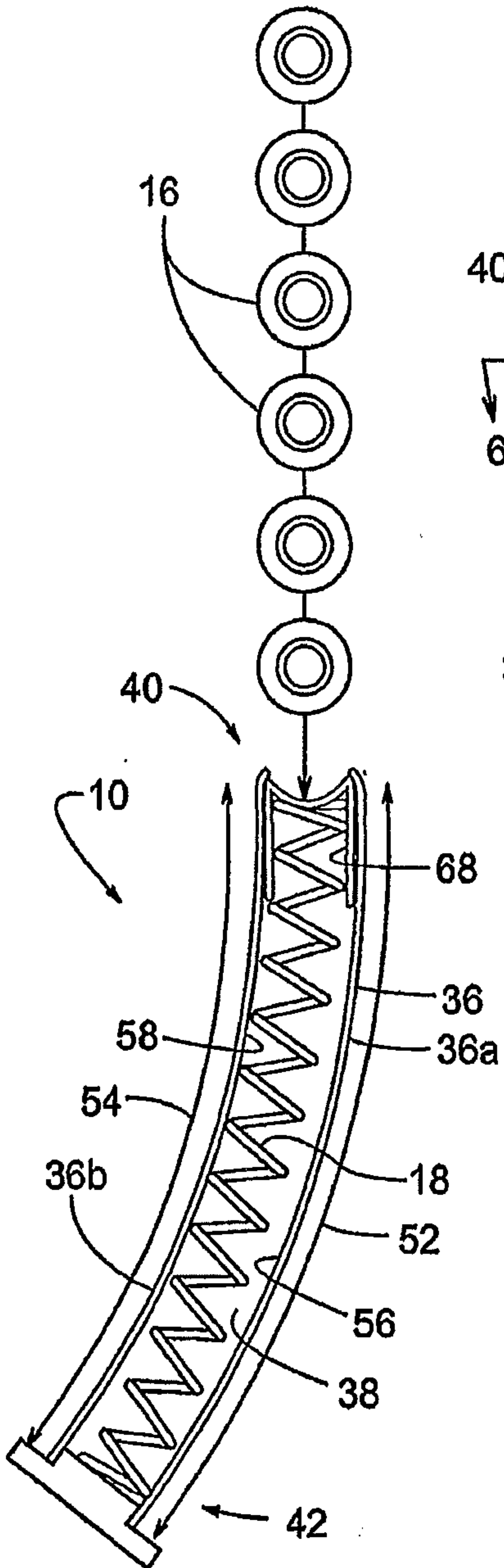

FIG. 7

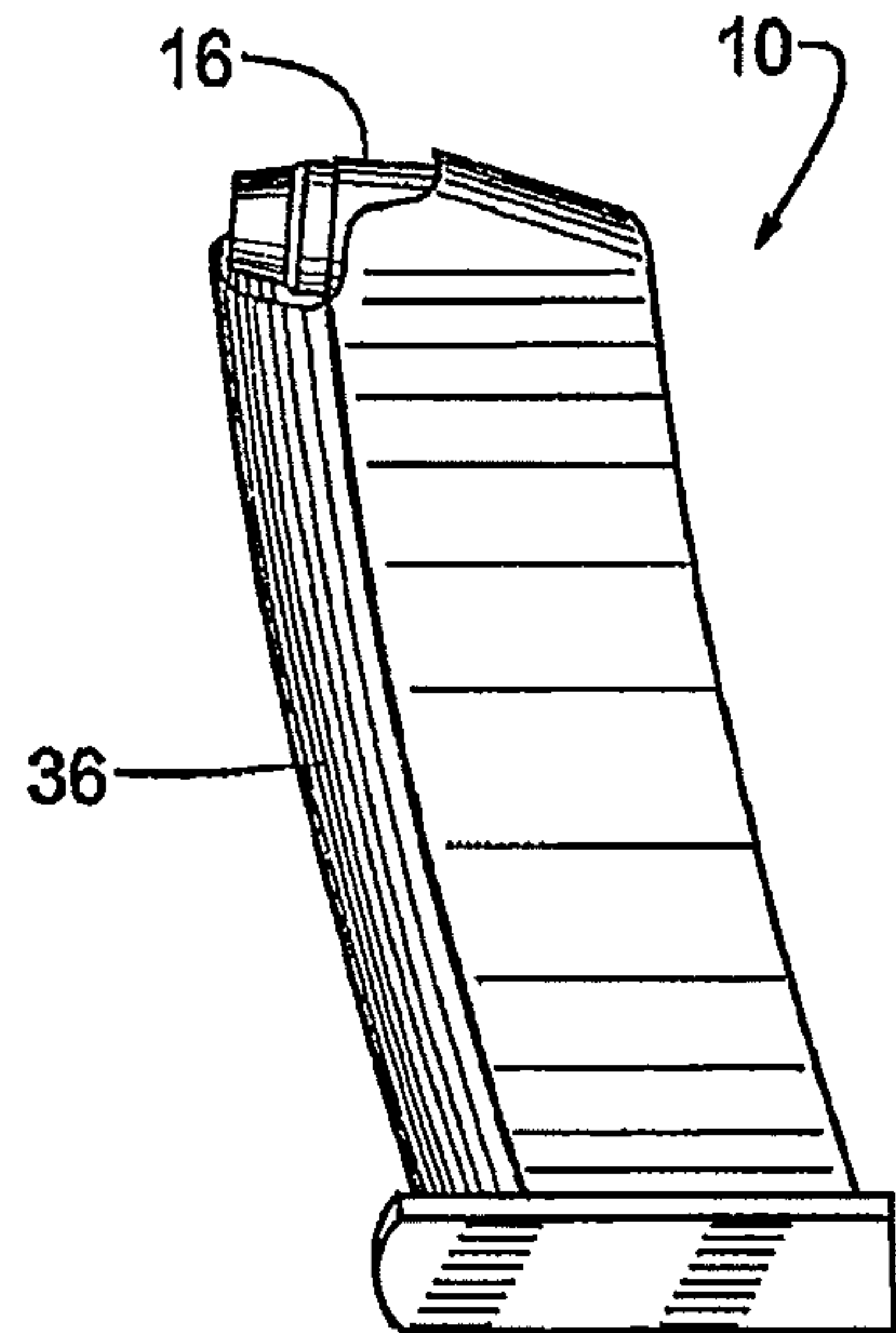

FIG. 8

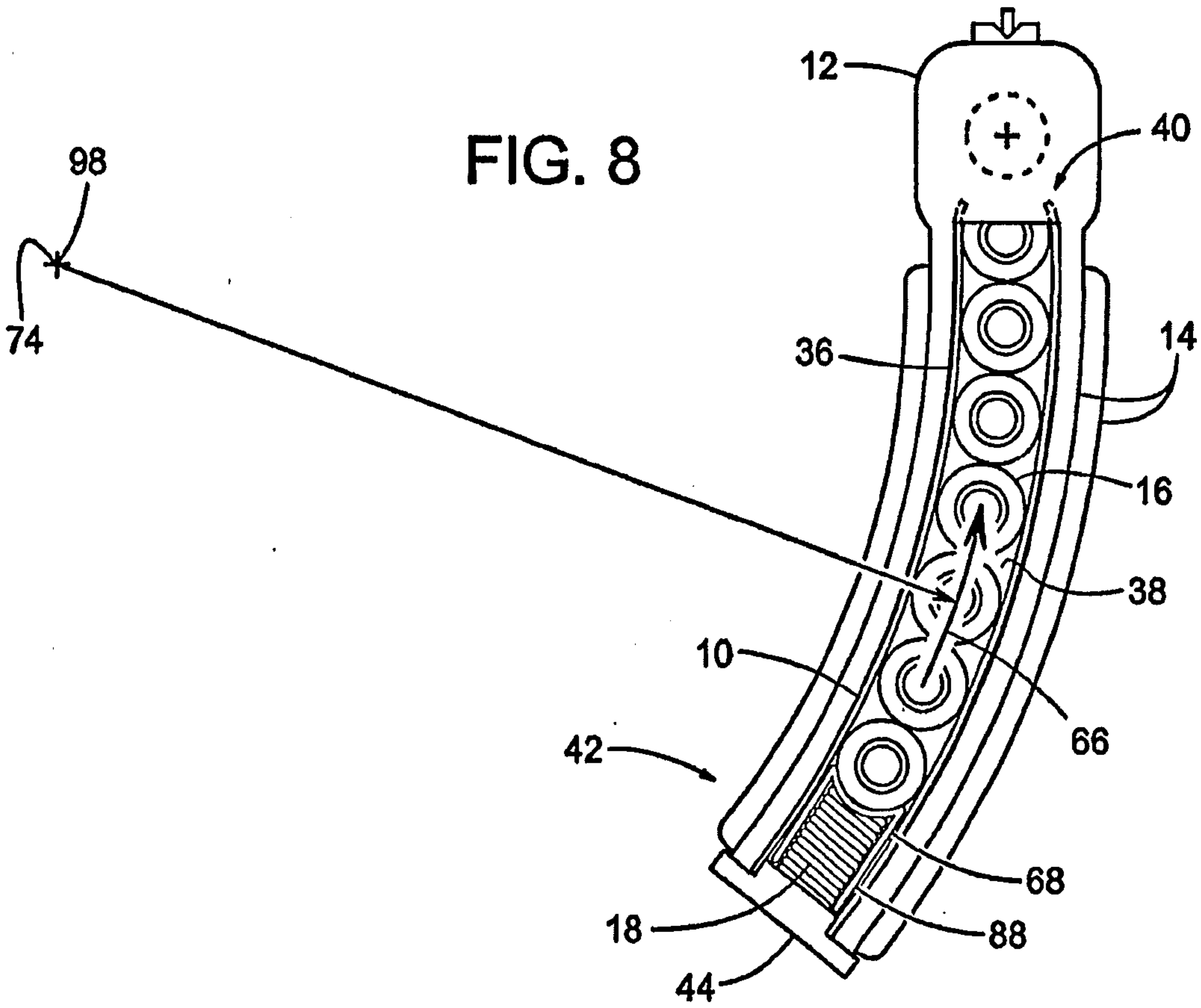
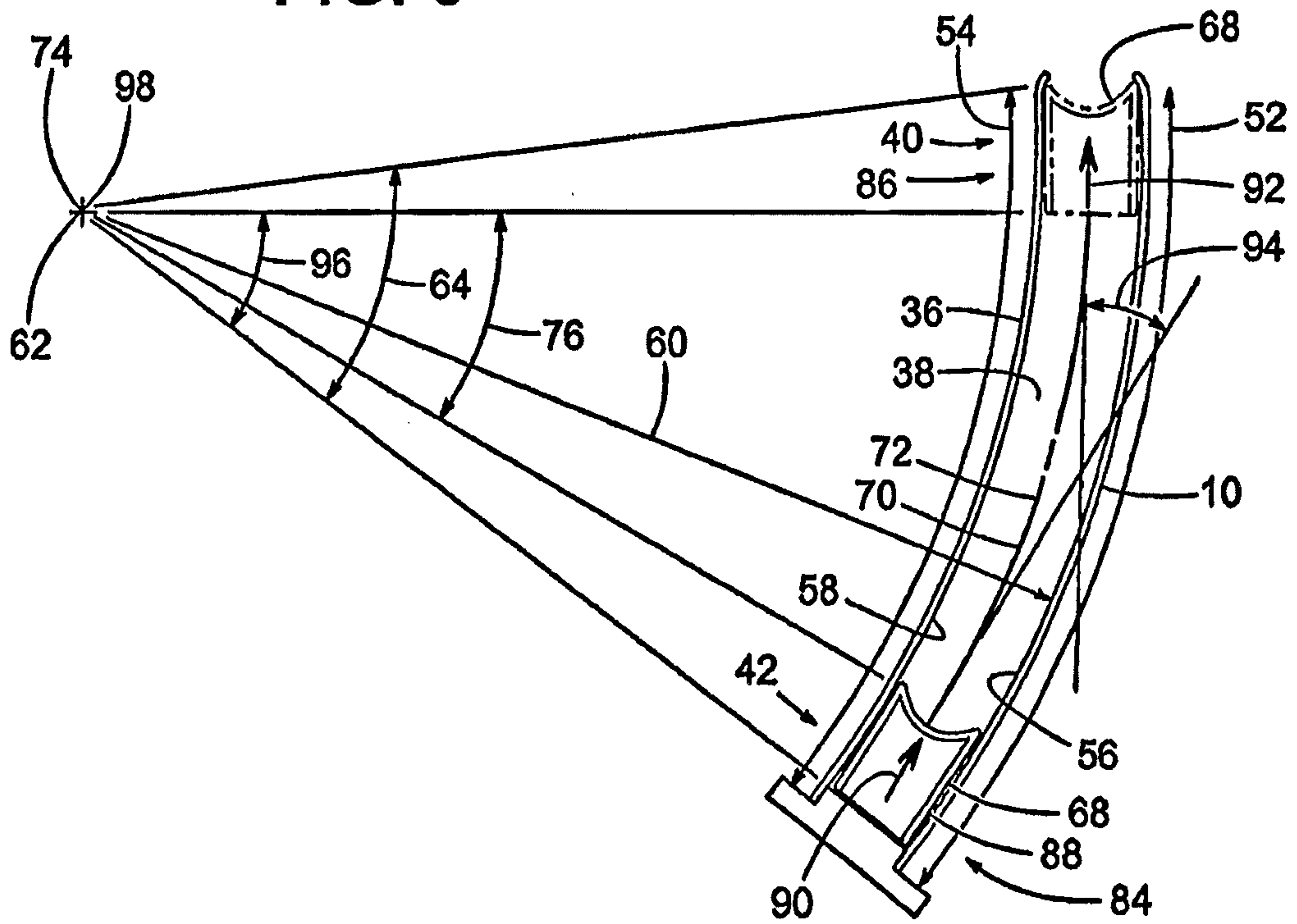

FIG. 9



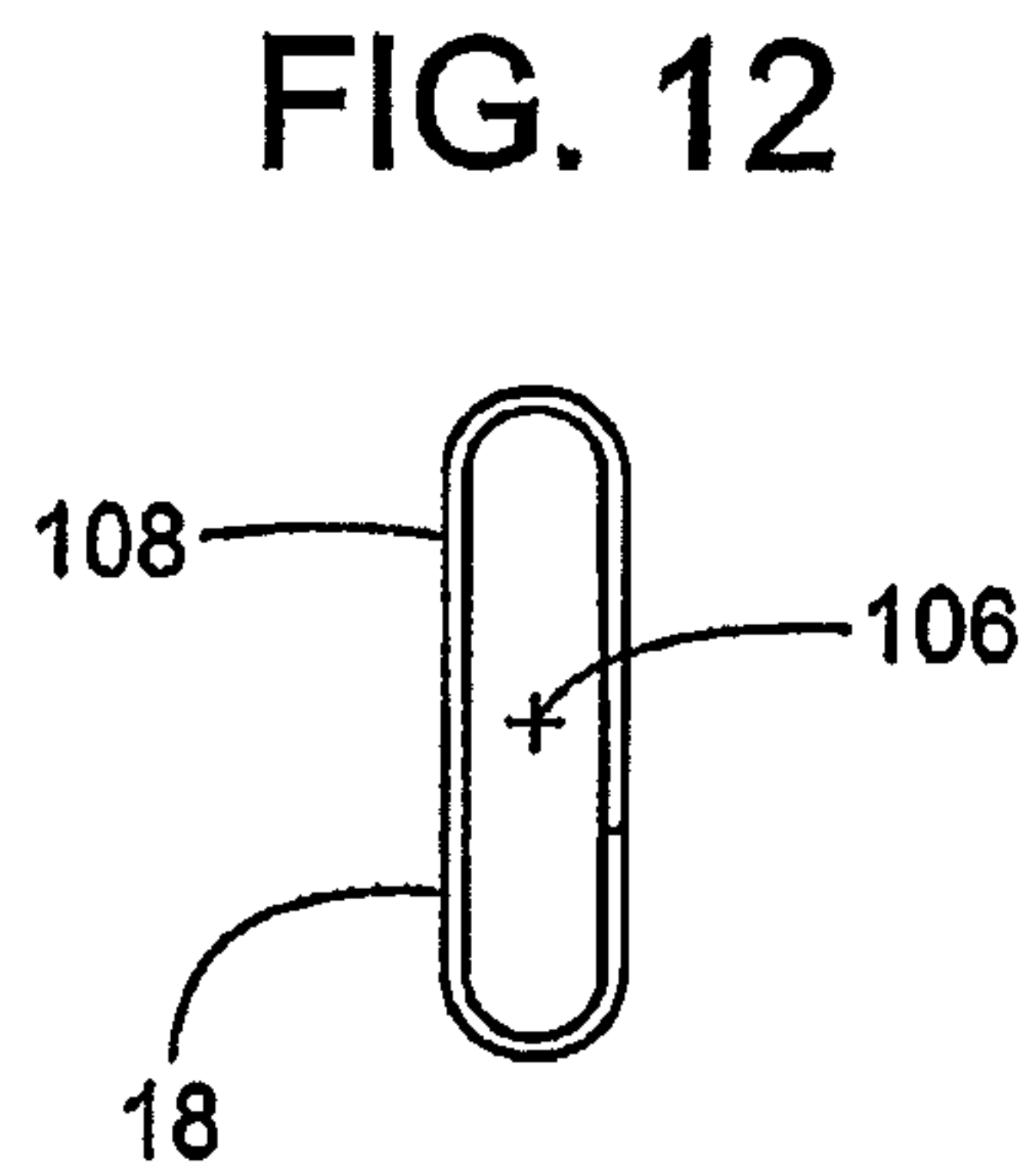
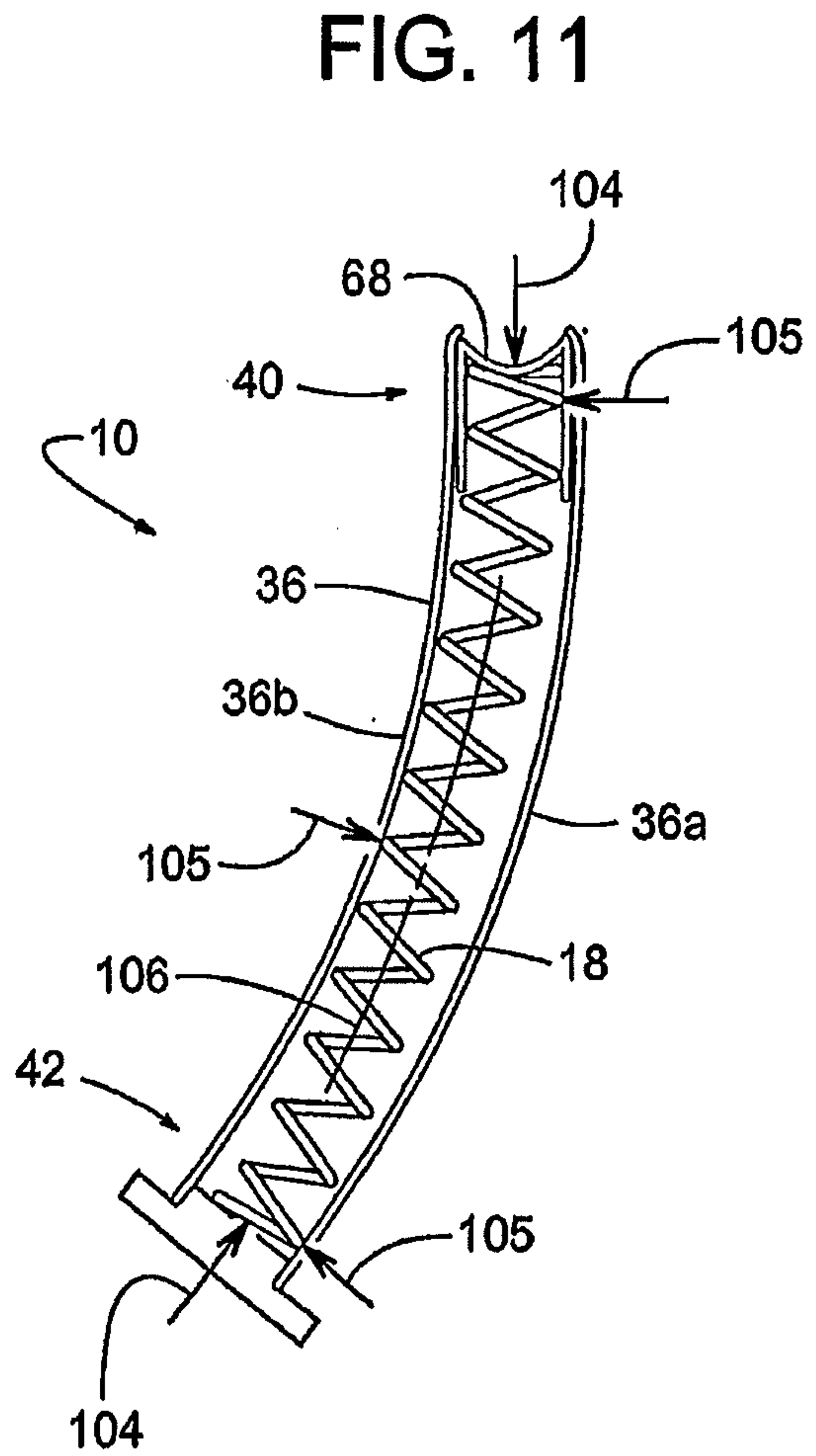
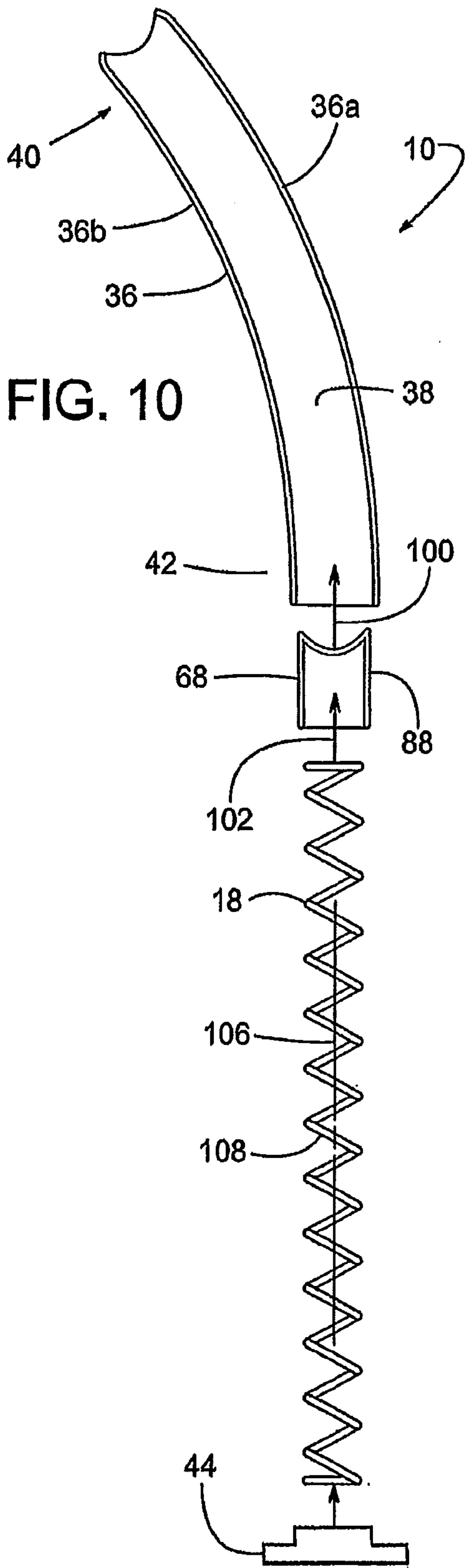

FIG. 13

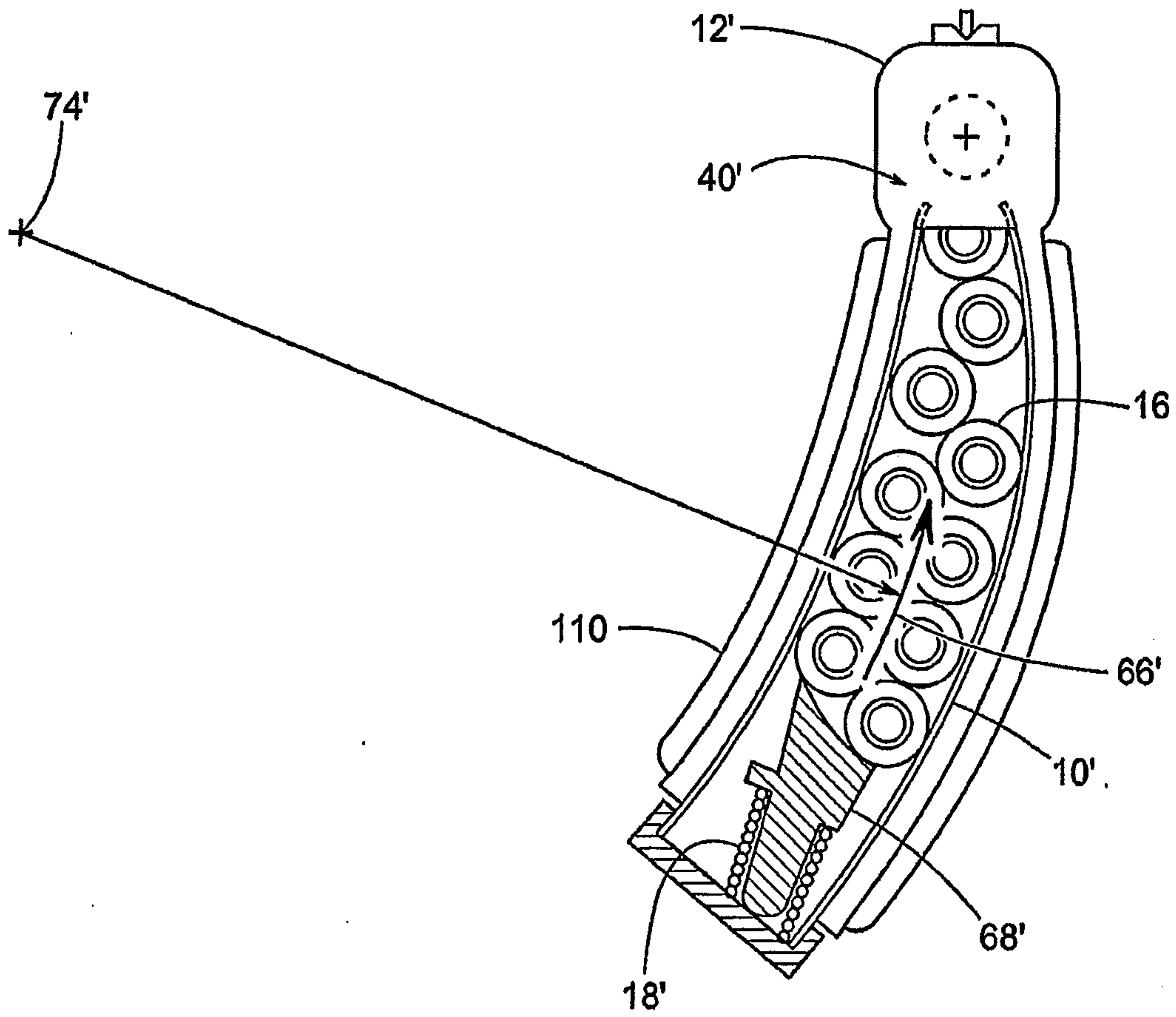

FIG. 3

