

(19)



(11)

EP 2 485 196 B1

(12)

EUROPEAN PATENT SPECIFICATION

(45) Date of publication and mention of the grant of the patent:
12.06.2013 Bulletin 2013/24

(51) Int Cl.:
G07F 13/10^(2006.01) G07F 11/42^(2006.01)
G07F 11/24^(2006.01)

(21) Application number: **12152487.0**

(22) Date of filing: **25.01.2012**

(54) **A vending machine for foods and products in general**

Verkaufsautomat für Lebensmittel und Produkte im Allgemeinen

Distributeur automatique pour aliments et produits en général

(84) Designated Contracting States:
AL AT BE BG CH CY CZ DE DK EE ES FI FR GB GR HR HU IE IS IT LI LT LU LV MC MK MT NL NO PL PT RO RS SE SI SK SM TR

(30) Priority: **04.02.2011 IT MI20110154**

(43) Date of publication of application:
08.08.2012 Bulletin 2012/32

(73) Proprietor: **Poleni, Rodolfo**
24036 Ponte San Pietro (Bergamo) (IT)

(72) Inventor: **Poleni, Rodolfo**
24036 Ponte San Pietro (Bergamo) (IT)

(74) Representative: **Lunati & Mazzoni S.r.L.**
Via Carlo Pisacane, 36
20129 Milano (IT)

(56) References cited:
EP-A1- 1 088 504 EP-A1- 1 588 981
EP-A2- 0 732 675 EP-A2- 0 950 996
EP-A2- 1 195 121 EP-A2- 1 564 696
EP-A2- 1 589 500 EP-A2- 1 672 597
EP-A2- 1 672 598 WO-A1-2005/076235

EP 2 485 196 B1

Note: Within nine months of the publication of the mention of the grant of the European patent in the European Patent Bulletin, any person may give notice to the European Patent Office of opposition to that patent, in accordance with the Implementing Regulations. Notice of opposition shall not be deemed to have been filed until the opposition fee has been paid. (Art. 99(1) European Patent Convention).

Description

[0001] The present invention relates to a vending machine for foods and products in general, of the type pointed out in the preamble of the first claim. Preferably, the vending machine is used for dispensing foodstuff, drinks or any other food items in response to a command/input supplied by the user.

[0002] Similar vending machines are described in patent applications: EP-A-1588981; EP-A-1672598 and EP-A-15646.

[0003] It is known that presently used vending machines or dispensers substantially consist of a single central body internally having said food items or the ingredients necessary for preparing them, suitably housed in the upper part thereof so as to facilitate movement of said articles, as hereinafter described.

[0004] In particular, in case of a dispenser of hot beverages, i.e. a dispenser suitable for preparation of the selected product, it contemplates a plurality of containers inside which the powdered ingredients are stored, a vessel containing water to be used for preparing the beverages and a preparation system adapted to select and mix the ingredients with water so as to make the selected product.

[0005] A plurality of interface elements are present on the outer surface of the central body, which elements enable a user to set the dispenser or vending machine in operation. In detail, these elements, preferably placed in the dispenser's upper part so as to facilitate use thereof, can comprise a push-button panel through which the product is selected and a payment apparatus by which, through insertion of coins for example, the amount corresponding to the selected product will be paid.

[0006] Finally, known vending machines, in the lower part thereof and, more specifically, under the interface elements and the products/ingredients, have a collection compartment inside which the product is collected and a picking up opening adapted to enable access to said compartment and through which the user removes the product by introducing his/her hand into said compartment.

[0007] In detail, access to said compartment is usually regulated through a vertically slidable plate so that, when the user picks up the product, he/she lifts said plate by one hand while he/she removes the product with the other hand, then moving his/her hands away from the compartment thus enabling the plate, pushed by the force of gravity, to close access to the inner compartment.

[0008] The known art mentioned above has some important drawbacks.

[0009] An important problem resides in that positioning of said elements and in particular the collection compartment and the inlet section makes use of a vending machine particularly uncomfortable. In detail, due to this uncomfortable positioning of the picking up opening, removal of the selected product from the collection compartment is made unpractical.

[0010] In fact the picking up opening, due to its relatively low position, forces the user to stoop down and bend forward and/or bend his/her legs and carry out the above described picking-up operations in this uncomfortable position.

[0011] In conclusion, these operations are particularly inconvenient and sometimes even impossible for old people or persons that, being for example in plaster, are at least partly disabled. In particular, use of a vending machine is difficult for persons sitting in a wheelchair as, due to the bulkiness of the latter and the too low position of the inner compartment, they are not able to reach the product and consequently to pick it up.

[0012] Under this situation, the technical task underlying the present invention is to conceive a vending machine for foods and products in general capable of substantially obviating the mentioned drawbacks.

[0013] Within the scope of this technical task, it is an important aim of the invention to provide a vending machine enabling simple and easy use of same by any type of user.

[0014] Another important aim of the invention is to conceive a vending machine enabling comfortable and practical picking up of the product.

[0015] The technical task and the aims specified are achieved by a vending machine for foods and products in general as claimed in the appended Claim 1. Preferred embodiments are highlighted in the sub-claims.

[0016] The features and advantages of the invention are hereinafter clarified by the detailed description of a preferred embodiment of the invention, with reference to the accompanying drawings, in which:

Fig. 1 shows a general view of the vending machine according to the invention;

Fig. 2 diagrammatically shows the vending machine in a moment of use; and

Fig. 3 is a perspective view of a device placed inside the machine.

[0017] With reference to the drawings, the vending machine or dispenser for foods and products in general according to the invention is generally denoted at **1**.

[0018] It is adapted to be used for dispensing beverages, foods, magazines or any other product suitably disposed and/or prepared inside the dispenser itself. In particular, the vending machine **1** is adapted to dispense a selected product **20** to a user **1a**, based on a command/input supplied by said user.

[0019] The vending machine **1** in known manner comprises a holding structure containing a plurality of products and defining a collection compartment **3** adapted to receive the selected product **20** and having an inlet section **3a** enabling picking up of the selected product **20** by the user **1 a**.

[0020] Preferably, the inlet section **3a** has a parallelogram-shaped profile adapted to promote extraction of the selected product **20**, as better described in the following.

In particular, it can be provided with a closing/opening mechanism, not shown in the figures, comprising a panel, a shutter or a plate adapted to close said section 3a and a motor or other actuating device adapted to move said plate so as to clear or close access to said section 3a.

[0021] Inside the holding structure the vending machine 1 has, in known manner, storage systems and dispensing mechanisms, not shown in the figures, that vary depending on the type of product delivered by dispenser 1.

[0022] For instance, should dispenser 1 be provided for dispensing previously packaged products, the holding structure would internally have a plurality of said previously packaged products and a dispensing mechanism adapted to move the selected product causing it to reach the collection compartment. Usually, the holding structure contemplates a series of shelves on which the products are disposed along orderly rows and, for each row of products, a helical element that, through rotation, causes advancing of the products of a row and then falling into compartment 3 of the head product corresponding to the selected product 20.

[0023] Alternatively, as in the example shown in Figs. 1-3, the vending machine 1, in addition to dispensing the selected product 20, is also adapted to prepare said product 20. Therefore, the holding structure has, in known manner, a plurality of containers in which the ingredients are housed and a particular distribution/preparation mechanism selecting the necessary ingredients and preparing the selected product 20.

[0024] The vending machine 1 in addition to the afore-said elements, comprises an innovative delivery mechanism 4 at least partly housed inside the collection compartment 3 and preferably fully housed in said compartment 3.

[0025] The delivery mechanism 4 comprises a support 5 adapted to define a supporting surface 5a on which the selected product 20 rests when it comes to the inside of the collection compartment 3; actuating means 6 adapted to extract the selected product 20 from the collection compartment 3; and a fastening body 7 suitable to enable constraint of the delivery mechanism 4 at compartment 3.

[0026] In detail, the actuating means 6 moves the support 5 and consequently the selected product 20 defining, for the delivery mechanism 4, a configuration at rest in which the support 5 is inside said collection compartment 3, and a grip configuration in which the support 5 is at the outside of compartment 3. Therefore, said means 6 moves support 5 and consequently the selected product 20 by a movement having a first component substantially perpendicular to the inlet section 3a so as to vary the distance of support 5 from the inlet section 3a.

[0027] Said first component can therefore be obtained through a translation along a movement plane parallel to said supporting plane of the vending machine 1. Alternatively, this first component is preferably obtained through rotation of support 5 relative to a rotation axis substantially perpendicular to the supporting plane of the

vending machine 1 and, more preferably, said first rotation is substantially of 90°.

[0028] Movement of support 5, obtained through the actuating means 6 is further characterised by the presence of a second component almost perpendicular to said supporting plane of the vending machine 1 and adapted to enable the height of the selected product 20 to be varied relative to the supporting plane of the dispenser. Preferably, said second component is adapted to determine a translation along said line perpendicular to the supporting plane that is substantially equal to 200 mm.

[0029] In conclusion, the actuating means 6 is adapted to extract the selected product 20 from the collection compartment 3 by shifting support 5 and consequently the selected product 20 by a movement having both the first component and the second component. The actuating means 6 is therefore adapted to make support 5 carry out a rotation-translation motion, i.e. move support 5 along a helical trajectory.

[0030] In said rotation-translation motion two distinct and simultaneous movements can be identified: a rotation movement defining the first component the width of which is substantially equal to 90° and which is carried out relative to an axis perpendicular to the supporting plane; and a translation movement defining the second component, along a direction almost parallel to said rotation axis.

[0031] The actuating means 6 can therefore be provided with a working screw 6a having a transverse extension direction, preferably perpendicular to the supporting plane of dispenser 1 and adapted to define at least the first component of motion of support 5; and guide locators including a housing 6b rigidly secured to the fastening body 7, which is adapted to guide movement of said support 5. Housing 6b preferably has a semicircular section so as to partly surround the working screw 6a; and a motor 6c adapted to move said working screw 6a. Housing 6b enables the above described helical motion of support 5 to be defined and is therefore advantageously provided with a slit 6d adapted to come into engagement, as better described hereinafter, with support 5 and having a profile substantially coincident with the above described helical trajectory so as to guide movement of support 5 in its rotational-translational motion, i.e. during passage of the delivery mechanism 4 from the at-rest configuration to the grip configuration (Fig. 3).

[0032] The support 5 has a first portion 5b defining the supporting surface 5a, a second portion 5c adapted to fasten support 5 between the actuating means 6 and body 7, and a third portion 5d adapted to connect said two portions 5b and 5c.

[0033] In particular, the first portion 5b, when dispenser 1 deals with previously packaged products such as drinks or sandwiches, consists of a suitably shaped plate or other similar element adapted to define an appropriate supporting surface 5a. Alternatively, when dispenser 1 deals with beverages contained in a glass 20a, such as

coffee and tea, the first portion 5b has a C-shaped profile, so as to at least partly surround and support glass 20a, as shown in Figs. 1-3. The second portion 5c is at least partly housed between the working screw 6a and housing 6b so as to enable engagement of support 5 both with screw 6a and with slit 6d. In particular, it consists of a hollow cylindrical body having an inner wall provided with threading so that it engages with the working screw 6a, and an engagement tooth 5e protruding from the outer surface of the cylindrical body and suitable for engagement with slit 6d.

[0034] The third portion 5d preferably has a substantially L-shaped profile in which the following parts can be identified: an initial plate, close to the second portion 5c, substantially parallel to the ground and of such a length that, when the mechanism 4 is in the grip configuration, it enables the first portion to fully come out of the collection compartment 3; and a final plate inclined to the former and adapted to keep the first portion 5a and consequently the selected product 20 in a raised position relative to the ground.

[0035] Dispenser 1 can comprise activation means adapted to operate activation of the delivery mechanism 4, i.e. of the means adapted to operate passage of the delivery mechanism 4 from the at-rest configuration to the grip configuration and vice versa. In addition, said activation means is also adapted to operate the above described closing/opening mechanism of the inlet section 3a.

[0036] This activation means comprises several sensors and in particular at least one sensor 8 adapted to automatically detect the presence of the selected product 20 on the first portion 5b of support 5. In detail, sensor 8 is a pressure sensor, i.e. a sensor capable of detecting the presence of the selected product 20 on support 5 due to the weight force, i.e. the force exerted by the product 20 on the sensor itself.

[0037] Finally, the vending machine 1 at the outer surface of the holding structure 2 corresponding to the inlet section 3a is provided with interface elements adapted to enable the user 1a to operate the vending machine 1.

[0038] In detail, the interface elements comprise a known payment apparatus 9 enabling the user 1a to pay the price corresponding to the selected product; and a push-button panel 10 for selection of the desired product from a plurality of products contained in the holding structure thereby allowing said command/input to be sent to the vending machine 1.

[0039] Preferably, the push-button panel 10 is such made as to define a pressure plane having a little inclination angle relative to the normal to the supporting plane of the vending machine 1, substantially of 3° for example. It has a series of inscriptions 10a, each identifying one of the products present in dispenser 1 and at least partly made in high relief relative to said pressure plane.

[0040] Operation of a vending machine or dispenser, described above as regards structure is the following.

[0041] First, the vending machine 1 has the delivery

mechanism 5 in the at-rest configuration and support 5 is therefore inside the collection compartment 3.

[0042] At the moment of use, the user 1 a selects a product 20 through the push-button panel 10, inserts the related amount through the payment apparatus 9 and activates the vending machine 1 that prepares the selected product 20 and places it on support 5 determining actuation of a sensor 8.

[0043] If the dispenser has to provide hot beverages, as shown in Figs. 1-3, dispenser 1 places the glass 20a on the first portion 5b close to sensors 8 and then fills the glass 20a with the selected beverage. In detail, filling of glass 20a gives rise to an increase in weight of the glass and therefore to actuation of sensors 8.

[0044] Once the selected product 20 is ready, sensors 8 activate the closing/opening mechanism that will open the inlet section 3a and, substantially simultaneously, the delivery mechanism 5 that moves from the at-rest configuration to the grip configuration.

[0045] During this passage from the at-rest configuration to the grip configuration, motor 5c sets the working screw 6a and support 5 in rotation, while housing 6b keeps stationary. In detail, said movement of support 5 relative to housing 6b causes sliding of the engagement tooth 5e inside slit 6d and therefore the helical motion (Fig. 3) of support 5 and of the selected product 20.

[0046] The selected product 20 substantially carries out a rotation of about 90° so that the selected product 20 is extracted from compartment 3, as well as a translation of at least about 200 mm raising the product itself. In detail, this double movement is facilitated by the parallelogram shape of the inlet section 3a that will prevent glass 20a and support 5 from bumping against the edge of section 3a.

[0047] When the delivery mechanism 4 comes to the grip configuration, it has the first portion 5b and, therefore, the selected product 20 fully out of the collection compartment 3. In particular, support 5 has the third portion 5d at least partly out of said compartment 3 and, more specifically, it has the second plate of the third portion 56d out of the collection compartment 3, as shown in Figs. 1 and 2.

[0048] Once the dispenser is in the grip configuration, the delivery mechanism 4 stops and waits for picking up of the product 20.

[0049] When the user 1 a picks up the product 20 from support 5, sensors 8 detect picking up and cause return of mechanism 4 to the at-rest configuration. In detail, in this second movement, rotation of the working screw 6a is opposite to that of the preceding motion and, therefore support 5 moves along the same trajectory, but in the opposite way.

[0050] When the delivery mechanism 4 is in the at-rest configuration, the closing/opening mechanism closes the inlet section 3a bringing dispenser 1 back to the initial state. The invention achieves important advantages.

[0051] The vending machine 1, when the selected product 20 has to be picked up, enables the latter to be

in a particularly comfortable and easy position for this operation. In fact, as shown in Fig. 1, dispenser 1 enables a user 1a to pick up the selected product 20 without said user being obliged to bend and/or to kneel down. In detail, due to the presence of the innovative delivery mechanism 4, the product 20 at the moment of picking it up is in an ideal position also for partly disabled people and/or people on wheelchairs.

[0052] Another advantage resides in the particular position of the push-button panel 10 that, being slightly inclined relative to the normal to the supporting plane of dispenser 1, offers a comfortable and practical supporting surface for the user's hand at the moment of selection.

[0053] A further advantage belonging to the vending machine 1 is obtained due to the inscriptions 10a that, being at least partly made in high relief, enable even the blind to easily identify the desired product.

[0054] Another important advantage is obtained by virtue of the parallelogram-shaped profile of the inlet section 3a as it prevents the support 5 from bumping against said profile during its movements, which will cause the selected product 20 to fall.

[0055] The invention is susceptible of variations falling within the scope of the inventive idea. All of the elements described and claimed can be replaced by equivalent elements and the details, materials, shapes and sizes can be of any nature and magnitude.

Claims

1. A vending machine (1) for foods and products in general adapted to dispense a selected product (20) and comprising a holding structure containing a plurality of products and defining a collection compartment (3) adapted to receive said selected product (20); said collection compartment (3) having an opening section suitable to enable said selected product (2c) to come out of said collection compartment (3); a delivery mechanism (4) including a support (5) adapted to hold up said selected product (20) when said selected product (20) is in said collection compartment (3); and actuating means (6) adapted to move said support (5) by a movement having a first component parallel to the line perpendicular to said opening section (3a) in a manner adapted to define an at-rest configuration of said delivery mechanism (4) in which said support (5) is inside said collection compartment (3), and a grip configuration in which said support (5) is at least partly at the outside of said collection compartment (3) said movement of said support (5) comprising a rotation the rotation axis of which is substantially perpendicular to the supporting plane of said vending machine (1) and a second component substantially transverse to said supporting plane of said vending machine (1) and **characterised in** said actuating means (6) has a working screw (6a) adapted to move said support

(5) in a substantially vertical direction, and guide locators for said support adapted to impose a rotational-translational motion thereto and **in that** said guide locators comprise a housing (6b) adapted to guide the movement of said support (5) and having a slit (6d) defining said rotational-translational motion; and wherein said support (5) has an engagement tooth (5e) suitable for engagement in said slit (6d).

2. A vending machine (1) as claimed in preceding claim, wherein said actuating means (6) is housed within said collection compartment (3).
3. A vending machine (1) as claimed in one or more of the preceding claims, comprising activation means adapted to control activation of at least said delivery mechanism (4).
4. A vending machine (1) as claimed in the preceding claim, wherein said activation means comprises at least one sensor (8) adapted to detect the presence of said selected product (20) on said support (5).
5. A vending machine (1) as claimed in one or more of the preceding claims, wherein said selected product (20) comprises a glass (20a) inside which a beverage is disposed and wherein said support (5) has a first portion (5b) with a profile adapted to at least partly surround said glass (20a).
6. A vending machine (1) as claimed in the preceding claim, wherein said first portion (5b) is fully out of said collection compartment when said delivery mechanism (4) is in the grip configuration.

Patentansprüche

1. Verkaufsautomat (1) für Lebensmittel und Produkte im Allgemeinen, der geeignet ist, ein ausgewähltes Produkt (20) auszugeben und Folgendes umfasst:

eine Struktur, die eine Vielzahl von Produkten umfasst und ein Sammelfach (3) definiert, das in der Lage ist, das ausgewählte Produkt (20) aufzunehmen, wobei das genannte Sammelfach (3) einen Eingangsabschnitt aufweist, der geeignet ist, die Entnahme des genannten ausgewählten Produkts (2c) aus dem genannten Sammelfach (3) zu gestatten und eine Ausgabevorrichtung (4) mit einer Halterung (5), die geeignet ist, das ausgewählte Produkt (20) zu tragen, wenn das genannte ausgewählte Produkt (20) sich im genannten Sammelfach (3) befindet, sowie Bewegungsmechanismen (6), die geeignet sind, die genannte Halterung (3) durch eine Bewegung zu verschieben, die eine erste Komponente parallel zur Senkrechten zu dem

- genannten Eingangsabschnitt (3a) auf eine Weise aufweist, die geeignet ist, eine Ruhekonfiguration der genannten Ausgabevorrichtung (4) zu definieren, bei der die genannte Halterung (5) sich im Inneren des Sammelfachs (3) befindet und eine Entnahmekonfiguration, bei der die genannte Halterung (5) sich mindestens zum Teil außerhalb des genannten Sammelfachs (3) befindet, wobei die genannte Bewegung der genannten Halterung (5) eine Drehung mit zur Ablagefläche des genannten Verkaufsautomaten (1) im Wesentlichen senkrechter Drehachse und eine zweite im Wesentlichen quer zu der genannten Ablagefläche des genannten Verkaufsautomaten (1) verlaufende Komponente umfasst, **dadurch gekennzeichnet, dass** die genannten Bewegungsmechanismen (6) eine Stellschraube (6a) aufweisen, die geeignet ist, die genannte Halterung (5) in im Wesentlichen vertikaler Richtung zu bewegen und durch Führungsanschlüsse der genannten Halterung, die geeignet sind, dieser eine verschiebende Drehbewegung vorzugeben; dabei umfassen die genannten Führungsanschlüsse ein Gehäuse (6b), das in der Lage ist, die Bewegung der genannten Halterung (5) zu führen, und eine Kerbe (6d) aufweist, die die genannte verschiebende Drehbewegung definiert und die genannte Halterung (5) weist einen Verbindungszahn (5e) auf, der geeignet ist, in die genannte Kerbe (6d) einzurastern.
2. Verkaufsautomat (1) nach einem oder mehreren der vorangegangenen Ansprüche, bei dem das Bewegungssystem (6) im Inneren des genannten Sammelfachs (3) untergebracht ist.
 3. Verkaufsautomat (1) nach einem oder mehreren der vorangegangenen Ansprüche, der Betätigungsmechanismen umfasst, die geeignet sind, zumindest die Betätigung der genannten Ausgabevorrichtung (4) zu steuern.
 4. Verkaufsautomat (1) nach dem vorangegangenen Anspruch, bei dem die genannten Betätigungsmechanismen mindestens einen Sensor (8) umfassen, der geeignet ist, das Vorliegen des genannten ausgewählten Produkts (20) auf der genannten Halterung (5) zu erfassen.
 5. Verkaufsautomat (1) nach einem oder mehreren der vorangegangenen Ansprüche, bei dem das genannte ausgewählte Produkt (20) einen Becher (20a) umfasst, in dessen Inneres ein Getränk gefüllt wird und bei dem die genannte Halterung (5) einen ersten Teil (5b) aufweist, der über ein Profil verfügt, das geeignet ist, den genannten Becher (20a) zumindest teilweise zu umschließen.
 6. Verkaufsautomat (1) nach dem vorangegangenen Anspruch, bei dem der genannte erste Teil (5b) sich vollkommen außerhalb des genannten Sammelfachs befindet, wenn die genannte Ausgabevorrichtung (4) sich in Entnahmekonfiguration befindet.

Revendications

1. Distributeur automatique (1) pour aliments et produits en général apte à distribuer un produit sélectionné (20) et comprenant : une structure pour contenir une pluralité de produits et définissant un compartiment de collecte (3) apte à accueillir ledit produit sélectionné (20) ; ledit compartiment de collecte (3) présentant une section d'entrée apte à permettre la sortie dudit produit sélectionné (2c) par ce compartiment de collecte (3), un mécanisme de livraison (4) comprenant un support (5) apte à soutenir ledit produit sélectionné (20) lorsque ledit produit sélectionné (20) se trouve dans ledit compartiment de collecte (3) ; et des dispositifs de mouvement (6) aptes à mettre en mouvement ledit support (3) par un mouvement présentant une première composante parallèle à la perpendiculaire à ladite section d'entrée (3a) d'une manière apte à définir une configuration de repos dudit mécanisme de livraison (4) dans laquelle ledit support (5) se trouve à l'intérieur dudit compartiment de collecte (3) et une configuration de préhension dans laquelle ledit support (5) se trouve, au moins partiellement à l'extérieur dudit compartiment de collecte (3), ledit mouvement dudit support (5) comprenant une rotation avec axe de rotation fondamentalement perpendiculaire au plan d'appui dudit distributeur automatique (1) et une seconde composante fondamentalement transversale audit plan d'appui dudit distributeur automatique (1) et **caractérisé en ce que** lesdits dispositifs de mouvement (6) présentent une vis de manoeuvre (6a) apte à mettre en mouvement ledit support (5) en sens fondamentalement vertical et des butées de guidage dudit support aptes à imposer à ce dernier un mouvement de rotation-translation ; et dans lequel lesdites butées de guidage comprennent une gaine (6b) apte à guider le mouvement dudit support (5) et présentant une fente (6d) définissant ledit mouvement de rotation-translation ; et dans lequel ledit support (5) présente un cran d'engagement (5e) apte à s'engager dans ladite fente (6d).
2. Distributeur automatique (1) selon une ou plusieurs des revendications précédentes dans lequel ledit dispositif de mouvement (6) est logé à l'intérieur dudit compartiment de collecte (3).
3. Distributeur automatique (1) selon une ou plusieurs des revendications précédentes, comprenant des moyens d'actionnement aptes à commander l'acti-

vation d'au moins ledit mécanisme de livraison (4).

4. Distributeur automatique (1) selon la revendication précédente, dans lequel lesdits moyens d'actionnement comprennent au moins un capteur (8) apte à détecter la présence dudit produit sélectionné (20) sur ledit support (5). 5
5. Distributeur automatique (1) selon une ou plusieurs des revendications précédentes, dans lequel ledit produit sélectionné (20) comprend un gobelet (20a) à l'intérieur duquel se trouve une boisson et dans lequel ledit support (5) présente une première partie (5b) ayant un profil apte à entourer au moins partiellement ledit gobelet (20a). 10 15
6. Distributeur automatique (1) selon la revendication précédente, dans lequel ladite première partie (5b) est entièrement à l'extérieur dudit compartiment de collecte lorsque ledit mécanisme de livraison (4) est en configuration de préhension. 20

25

30

35

40

45

50

55

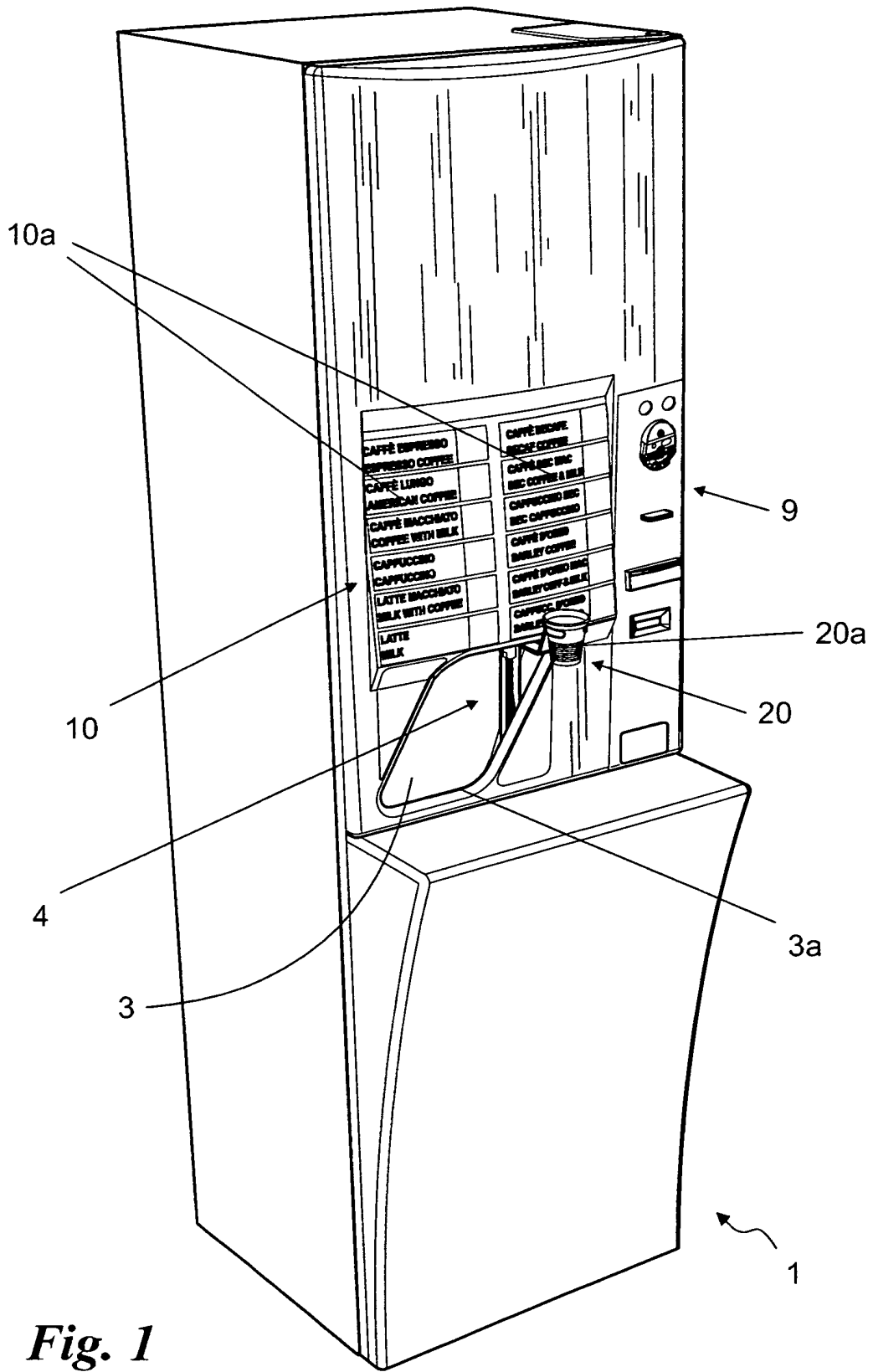
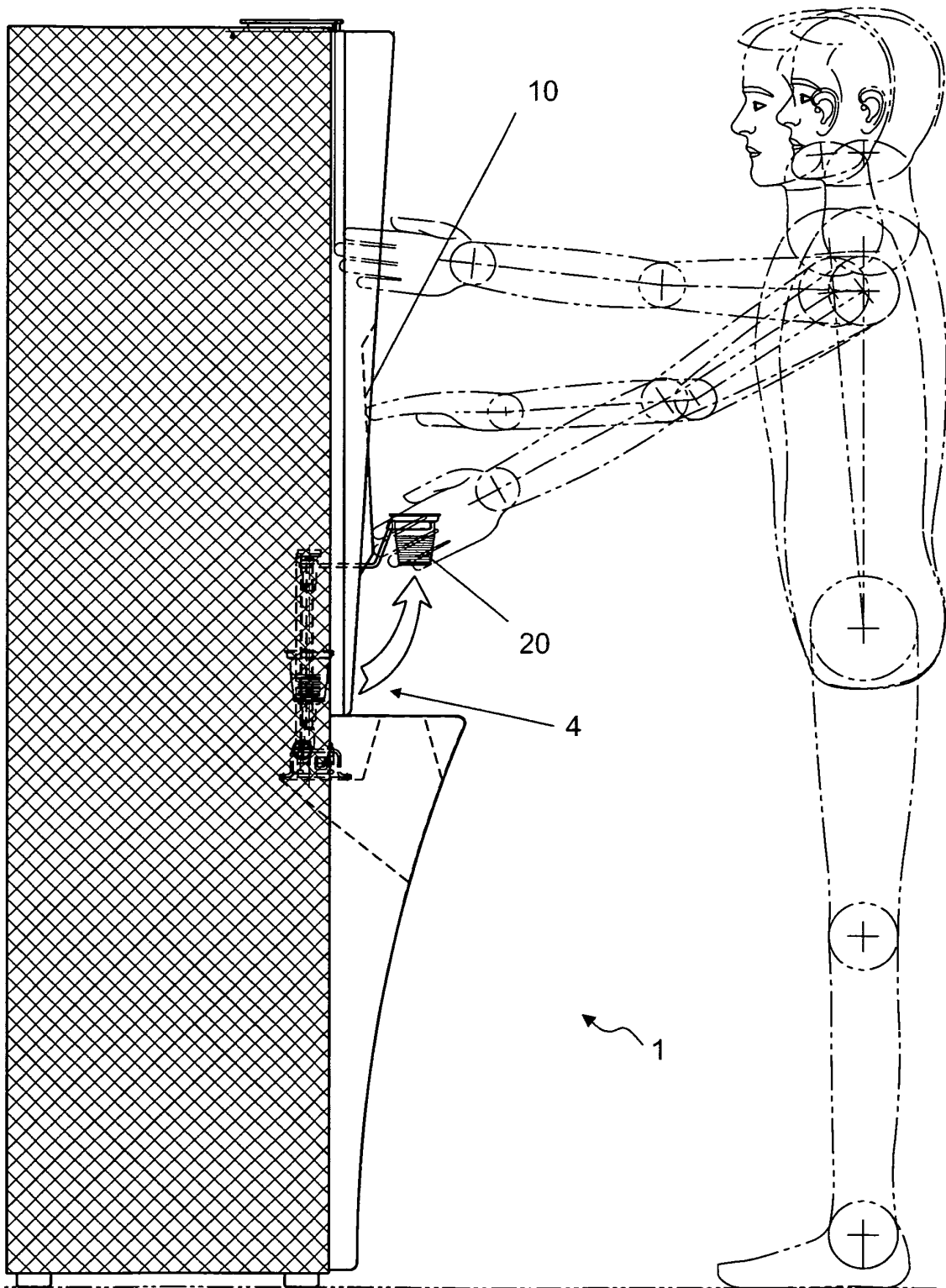

Fig. 1

Fig. 2



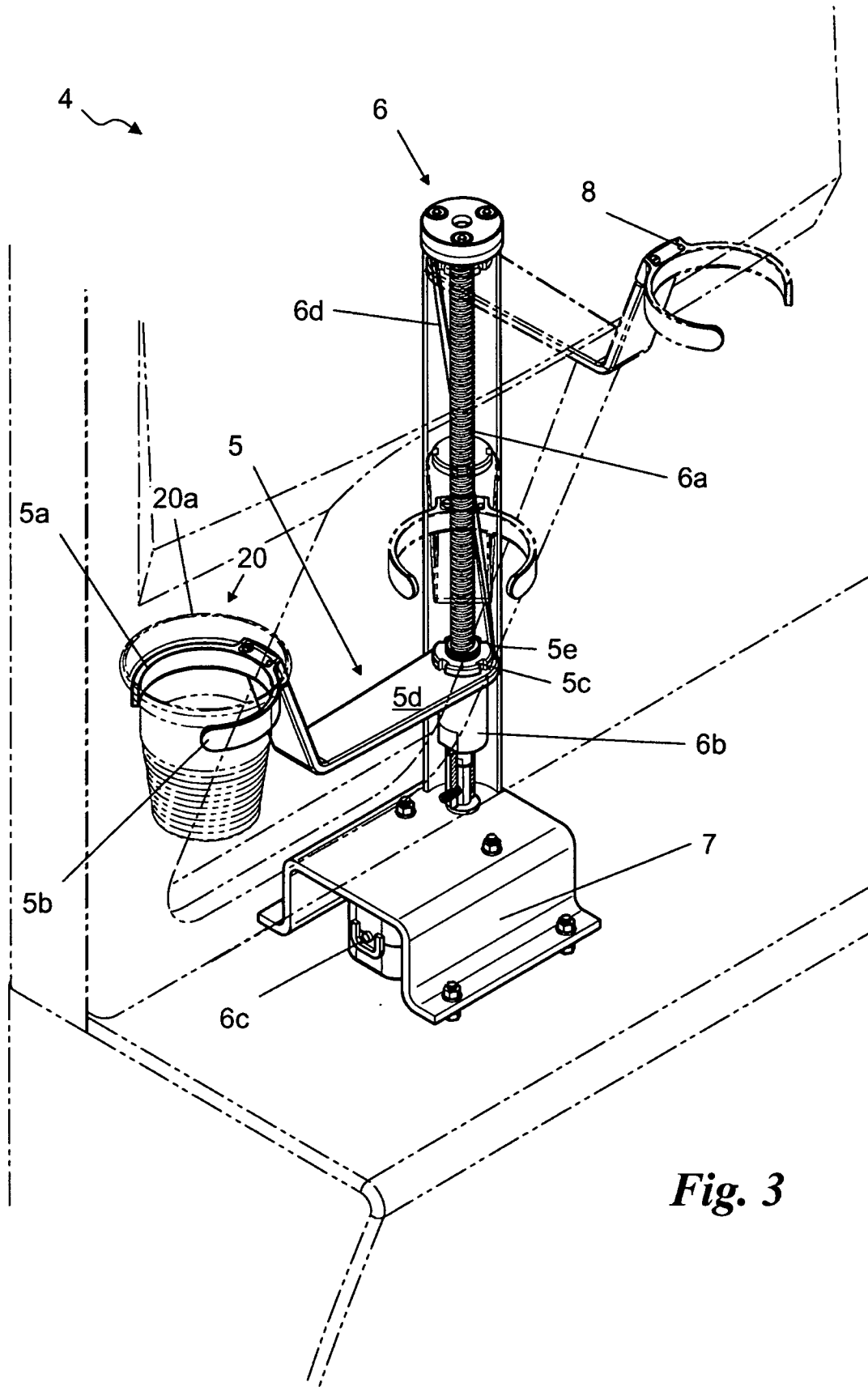

Fig. 3

REFERENCES CITED IN THE DESCRIPTION

This list of references cited by the applicant is for the reader's convenience only. It does not form part of the European patent document. Even though great care has been taken in compiling the references, errors or omissions cannot be excluded and the EPO disclaims all liability in this regard.

Patent documents cited in the description

- EP 1588981 A [0002]
- EP 1672598 A [0002]
- EP 15646 A [0002]