

19



Europäisches Patentamt
European Patent Office
Office européen des brevets



11 Publication number:

0 651 967 A1

12

EUROPEAN PATENT APPLICATION

21 Application number: **94117003.7**

51 Int. Cl.⁶: **A47L 15/48**

22 Date of filing: **27.10.94**

30 Priority: **04.11.93 IT MI932348**

43 Date of publication of application:
10.05.95 Bulletin 95/19

84 Designated Contracting States:
AT BE CH DE DK ES FR GB IE LI LU NL PT SE

71 Applicant: **VELOX BARCHITTA s.a.s. DI BUTTI
CARLANTONIO & C.**
Via Santi, 10
I-20030 Senago (Milano) (IT)

72 Inventor: **Butti, Carlantonio**
Via Massena, 8
I-20145 Milano (IT)

74 Representative: **Zavattoni Gusmeroli, Maria
Chiara**
Dr. Ing. A. Racheli & C. s.r.l.,
Viale San Michele del Carso, 4
I-20144 Milano (IT)

54 **Compact, twin-chambered apparatus for washing and drying tableware, and procedure.**

57 An apparatus for washing and drying tableware has two chambers (114,116), one for washing and rinsing (114), the other (116) for drying and disinfection, that are adjacent to each other and separated

by a door (120) that slides between an open position and a tight closed position. Each chamber has its own dish-rack feed device (143,147).

FIG. 5

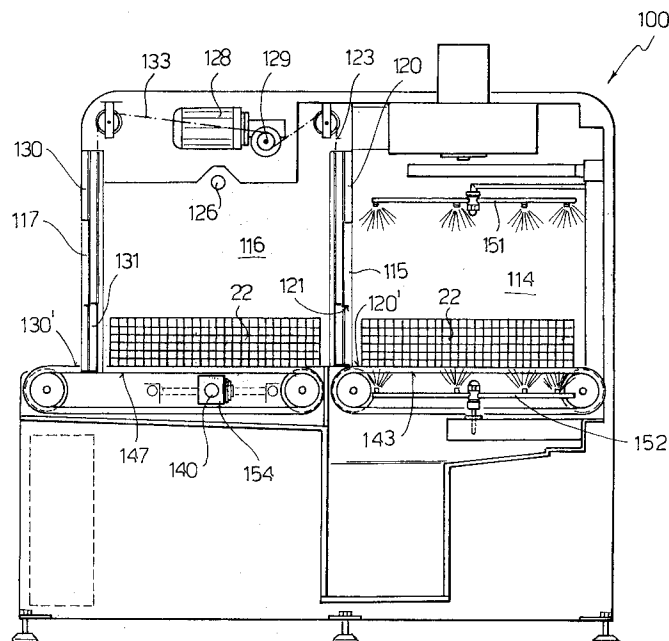

EP 0 651 967 A1

In the field of apparatus for washing and drying dishes the state of the art essentially comprises two classes of apparatus: large apparatus for industrial use or for large communities (for example, hospitals) and small apparatus for use in the home, in bars or in small commercial enterprises.

The former generally have no space restrictions and comprise a series of chambers, one for each operation, for example a pre-washing chamber, a washing chamber, a rinsing chamber, and a drying chamber, the chambers being physically at a sufficient distance from each other for the water that performs a function in one chamber not to mix with the water that performs another function in another chamber. The dishes are conveyed through the chambers inside racks that are suitably driven by a single conveyor belt system that passes along the different chambers; the chambers always communicate with each other, or else flexible curtains are provided between one chamber and the other which obviously do not create a tight closure. An example of such apparatus is described in EP-A-O 512 691. These apparatus wash the dishes in a satisfactory manner, but require large spaces for installation; in addition a good separation is not always achieved between washing water and rinsing water.

The machines of the second type carry out all the operations in succession in a single environment in which the dishes are placed in a rack that remains fixed during the series of operations. This leads to inferior practical and hygienic results, in that it is impossible to accommodate a wash/rinse system and at the same time a drying/disinfecting system in a single chamber.

The aim of the present invention is to provide a machine for washing tableware that affords the advantages of both of the previous solutions, i.e. that is of limited size and nevertheless allows hygienically optimal washing and drying.

These aims have been achieved with an apparatus as claimed in claim 1 and a procedure as in claim 9.

Further characteristics are stated in the subsequent claims.

The new apparatus comprises two adjacent intercommunicating chambers separated from each other by a door that can be opened and closed in a watertight manner and a rack conveyor system that is able to transfer the rack from one chamber to the other while the door is raised and out of the second chamber, according to a predetermined program that also controls opening and closing of the doors. According to a further characteristic the second chamber also comprises at least one or more germicidal lamps one of which is preferably mounted so that it can move along at least part of the rack conveying system.

The new apparatus performs rapid and perfectly hygienic washing of the dishes but requires a limited space, so that it can even be installed in bars, small restaurants, hospital wards, etc.

An exemplary embodiment of the invention will be described below with reference to the appended drawings in which it is illustrated and in which:

- 5 figure 1 is a schematic front view of the apparatus of the invention, with the loading door open, on a reduced scale;
- 10 figure 2 is a left view of the apparatus in figure 1;
- 15 figure 3 is an axonometric view of the rack transport device;
- figure 4 is an axonometric view of a part of the apparatus in figure 1, enlarged with respect to the previous figures;
- 20 figure 5 is a schematic front view, with the front panel removed, of a variant of the apparatus.

With reference to figures 1-4, the dish washing apparatus is indicated as a whole by the reference number 10 and comprises a fixed casing 12, forming a first washing/rinsing chamber 14 (with steam outflow by means of a fan) and a second drying/disinfecting chamber 16, a conveyor system 18 to take the racks from one chamber to the other; and a door system essentially comprising a door 20 that closes between the chamber 14 and the chamber 16.

The washing and rinsing chamber 14 is equipped in the usual manner with fixed or rotating washing and water spraying nozzles, which will not be described here in detail as they are known in themselves and can be easily applied by any technician in the field.

The drying/disinfection chamber 16 is equipped with wet air outflow devices and hot air input devices which are not described here because they are accessible to any technician in the field.

In the particular embodiment illustrated, the entrance for the dish-racks is foreseen at the front; a hinged, manually operated door is indicated by 21 and shown lowered, but a different position could be envisaged for the entrance. The dishes are arranged on racks indicated by 22 in the figures, which can be configured internally with any form of support for said dishes (not illustrated). In particular two racks 22 can be handled simultaneously, one in the washing chamber 14 and one in the chamber 16.

Above the chamber 14 a motor 24 for a ventilator aspirator 25 for said chamber can be seen.

The chamber 16, as mentioned above, comprises a traditional drying system, for example with hot air, which is not shown; it is also equipped with

one or more germicidal lamps, indicated by 26, that are known in themselves, for example various models of ultraviolet lamps.

A motor 28 mounted on a roof 27 above the chamber 16 provides for coordinated opening and closing of the middle door 20 and an exit door 30. Both doors preferably slide vertically in special lateral tracks in the structure and, in the lowered or closed position (dashed and dotted line), they shut against a substantially horizontal surface, respectively 20' separating the chambers, and 30'. The door movement can be achieved in any manner. In the example in the figures the motor 28 drives a shaft 29 with which two drive pulleys 31, 32 are integral; around each pulley winds a belt or rope or the like 33 anchored to the door 30 and 34 anchored to the door 20, respectively. The arrangement is such that opening of both doors is simultaneous. Obviously provision can be made for the doors not to be opened simultaneous or for opening to be brought about in another way, as desired.

The rack conveying or handling device can be seen in figure 3 and essentially comprises, for each chamber, a pair of parallel horizontal pulley-bearing shafts, connected by means of belts; the shafts in the washing chamber are indicated by 41 and 42 and the relative belt(s), chain(s) or band(s) by 43; the shafts in the drying chamber are indicated by 45 and 46 and the relative belt(s), chain(s) or band(s) by 47. The arrows indicate the direction of travel of the racks and the direction of entry.

A system of transmission belts 48, 49, 50 connects the two sets of belts and transmits the movement starting from a drive pulley 51. The system of belts 48, 49, 50 is preferably situated outside the chambers.

The apparatus works as follows. The dishes to be washed are arranged on a rack 22 and the rack is introduced into the washing chamber 14; the side door 21, of a traditional type, is then shut. Washing takes place with both doors 20 and 30 lowered. At the end of the washing cycle the motor 28 raises the doors 20, 30 and the transfer device 18 transfers the rack 22 from chamber 14 to 16, that is to say, the bands 43 convey the rack onto the bands 47, which carry it into the drying position. The doors 20 and 30 are then lowered again and drying takes place by blowing in hot air in a conventional way and disinfection by means of germicidal lamps 26. The doors 20 and 30 are then raised again and the rack is evacuated onto the resting table 52. It is possible to carry out a washing/rinsing for a rack 22 positioned in chamber 14 at the same time as a drying/disinfecting for another rack 22 positioned in chamber 16; at the end of said operations, the dried rack is evacuated at the same time as the washed rack passes into the drying chamber.

The various operations (washing, rinsing, steam exhaust, opening of the door separating the chambers, translation of the rack from the washing chamber to the drying/sterilisation chamber, closing of the doors, drying, germicidal action) and the operating variables, temperatures and times are preferably computer-controlled; the washing operations can be started only if a sensor detects a rack in the washing chamber and the doors are found to be in the closed position.

Figure 5 shows a variant of the apparatus indicated by 100. Some parts of the apparatus 100 are similar to those of the apparatus 10; they have the same numbers but increased by 100 and will not be described in detail.

The apparatus 100 thus comprises a washing/rinsing chamber 114 and a drying/disinfection chamber 116, adjacent to each other and communicating through an opening 115. The chamber 114 communicates with the outside through a loading opening with a door (not shown) that can be opened manually, for introduction of the racks 22. The chamber 116 communicates with the outside through an opening 117. The openings 115 and 117 are closed tight by means of raisable doors in a plurality of sections, indicated as a whole by 120 and 130 respectively. A bottom section of each of these, 121, 131 respectively, is joined to a raising chain, 123, 133 respectively, each operated by a motor 128, so that they wind and unwind simultaneously; raising of each bottom section therefore causes successive raising of the other sections, which thus remain grouped in the appropriate space at the top of the machine. Unwinding of the cables 123, 133 allows the sections to be lowered by gravity until they are positioned to form a seal between each other and against the surfaces 120' and 130' of the apparatus (which are generally the surfaces that define the lower water collection tanks). The transfer system for the racks 22, indicated by the bands 143 and 147, is substantially similar to that of the preceding apparatus. The water supply system, illustrated here as two rotary sprayers, an upper one 151 and a lower one 152, is also of the traditional type.

In the drying/disinfection chamber 116, besides an upper germicidal lamp 126, at least one lower germicidal lamp 154 is provided, mounted so that it can move longitudinally and/or transversally, with any known system: In this case also computer control is foreseen.

Operation of the machine will now be described.

On opening the front loading door, after the machine has completed the loading cycles and the parameters (temperatures) have been reached, the computer gives its consent for the operations.

When the rack is inserted into the washing chamber, the rack sensor enables the washing chamber for operation.

When the loading door is closed, if doors 120, 130 are open, they close and a door closure sensor initiates the washing program (the times of which can be set on the control computer). On completion of the washing time, rinsing is carried out, for a time that can be set. Once rinsing is finished, a fume exhaustion fan comes into operation and frees the chamber of all steam.

When the cycle is over the computer opens the intermediate doors and transfers the washed rack to the drying chamber.

Once the rack has arrived in the correct position, a sensor sends the computer the signal to close the doors and start the drying and germicidal ray cycle.

After a certain drying time, which eliminates the vast majority of the residual water, the lamps come into operation and carry out their germicidal action for predetermined times, stopping when drying is completed.

In the meantime the washing chamber is free and can be used for washing another rack, irrespective of whether the drying area is in operation or not.

In the event that a rack is being processed in the drying chamber and another in the washing chamber, the computer takes care of interfacing of the two chambers and waits until both have finished the cycle before transferring the rack being washed to the drying chamber and the one being dried to the external resting table.

Claims

1. An apparatus for washing and drying dishes, characterised by the fact that it comprises: a washing-rinsing chamber (14; 114) and a drying chamber (16; 116); a system to convey the dish racks (22) from one chamber to another; said two chambers being adjacent, with a communicating opening that can be closed in a watertight manner by a door (20); said conveying system comprising a feed device (43; 143) for the washing-rinsing chamber and a feed device (47; 147) for the drying chamber.
2. An apparatus according to claim 1, characterised in that it also comprises at least one germicidal lamp (26; 126) in the drying chamber (16; 116).
3. An apparatus according to claim 1, characterised by the fact that it comprises a further

door (30; 130) at the exit from the drying chamber (16; 116) and said middle door (20; 120) and said further door (30; 130) are moved in unison by a single motor (28; 128).

4. An apparatus according to claim 3, characterised by the fact that the doors slide vertically on tracks and the motor (28) drives belts (33, 34) that raise said doors.
5. An apparatus according to claim 3, characterised by the fact that each of said doors (120, 130) is made of plurality of sections that slide vertically reciprocally, and said motor (128) is connected with flexible means (123, 133) to the most distant sections.
6. An apparatus according to claim 2, characterised by the fact that it comprises at least one lower germicidal lamp.
7. An apparatus according to claim 2, characterised by the fact that said germicidal lamp is mounted so that it can translate longitudinally and/or transversally with respect to the direction in which the racks are conveyed.
8. An apparatus according to claim 3, characterised by the fact that it comprises a control device to co-ordinate operations for opening and closing of the doors and feeding of the rack conveying devices.
9. A procedure for washing/rinsing/drying of tableware in racks in an apparatus according to claim 3, comprising the phases of
 - a) washing/rinsing of the tableware in the washing/rinsing chamber;
 - b) conveying of the rack(s) from the washing chamber to the drying chamber;
 - c) drying, possible disinfection of tableware in the drying chamber
 characterised by the fact that phases a) and c) take place with the racks at a standstill.
10. A procedure according to claim 9, characterised by the fact that the end of phase a) and phase c) determines the start of phase b) and opening of the doors, whilst the end of phase b) determines the start of phases a) and b) and closing of the doors.
11. A procedure according to claim 9, characterised by the fact that, at an interval from the start of drying, the start of disinfection with germicidal lamps is determined.

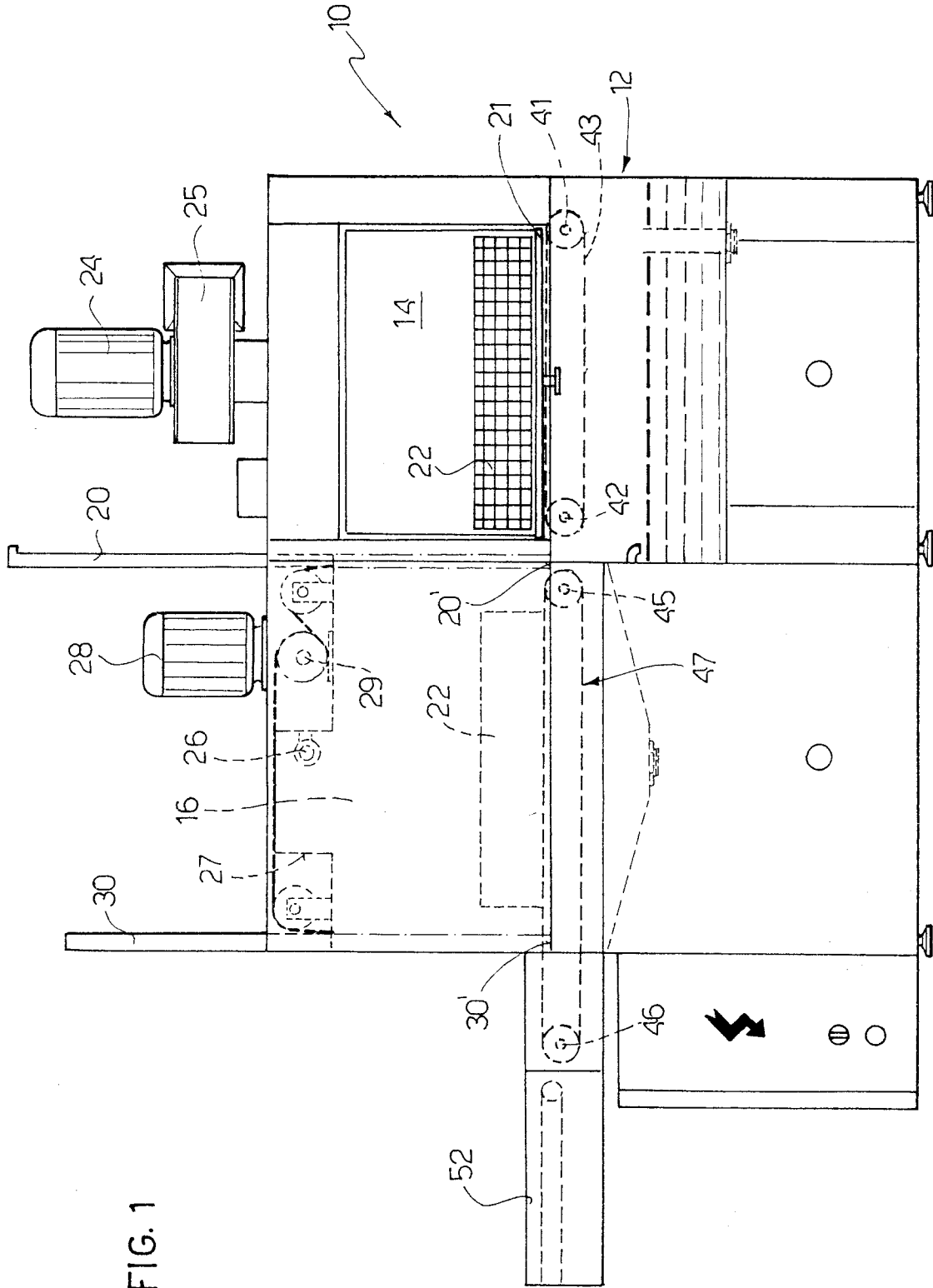
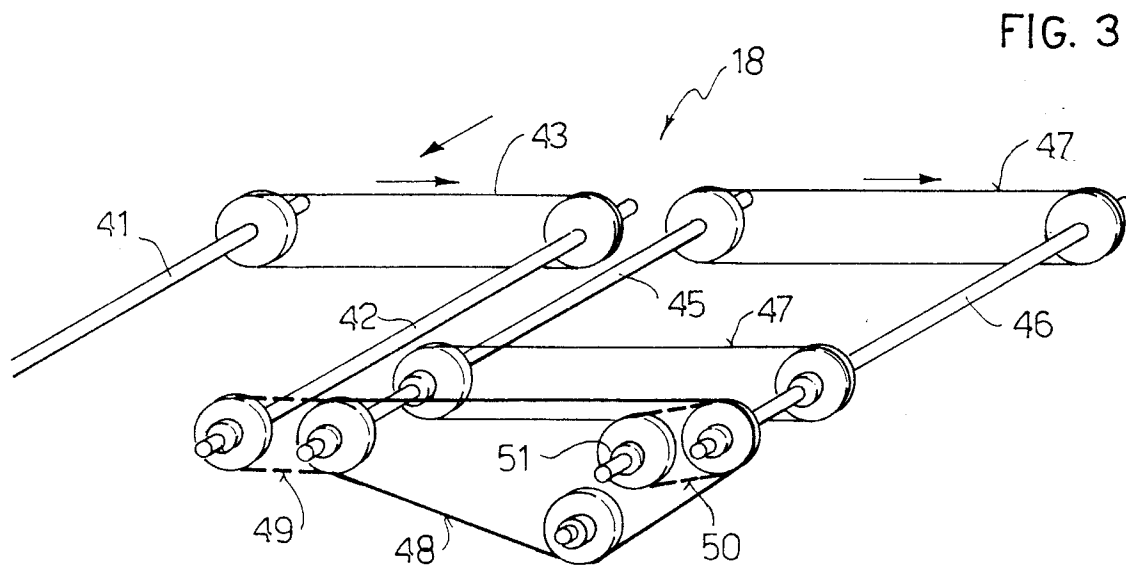
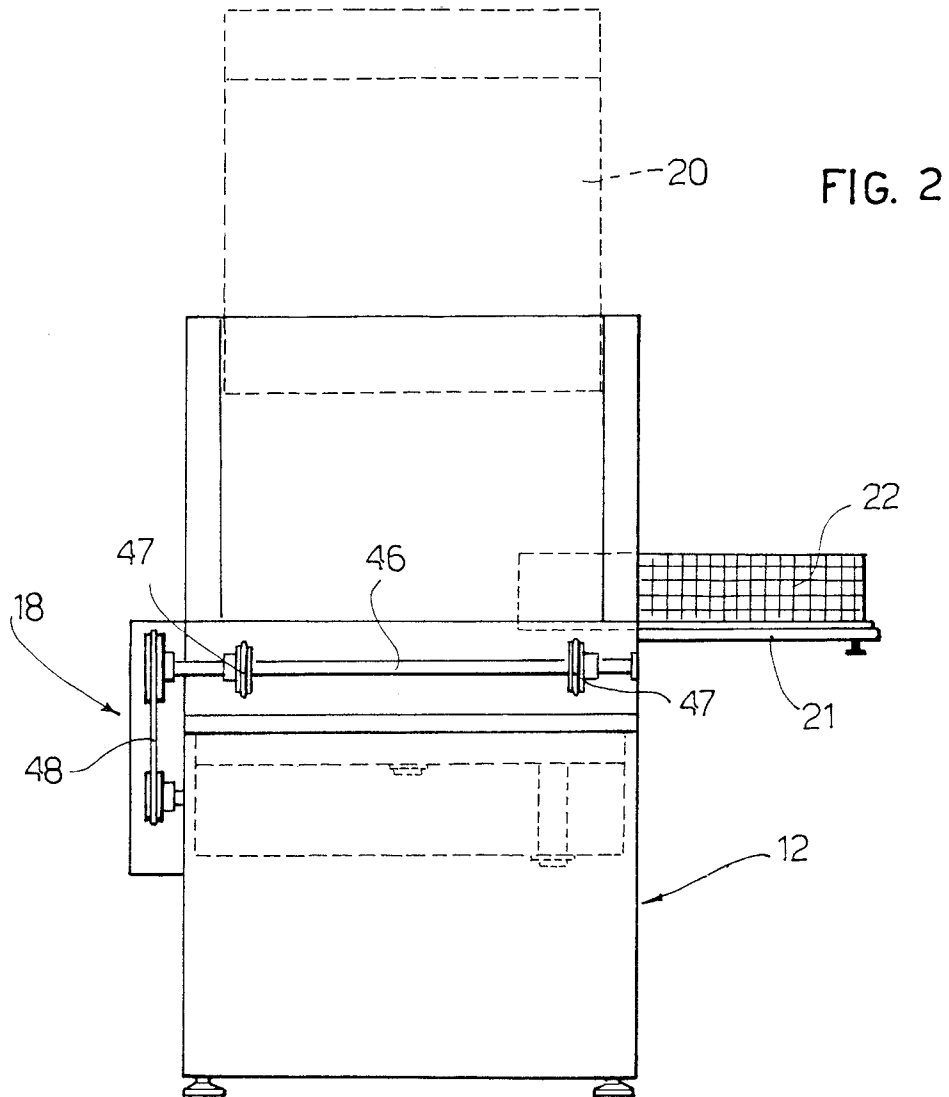

FIG. 1



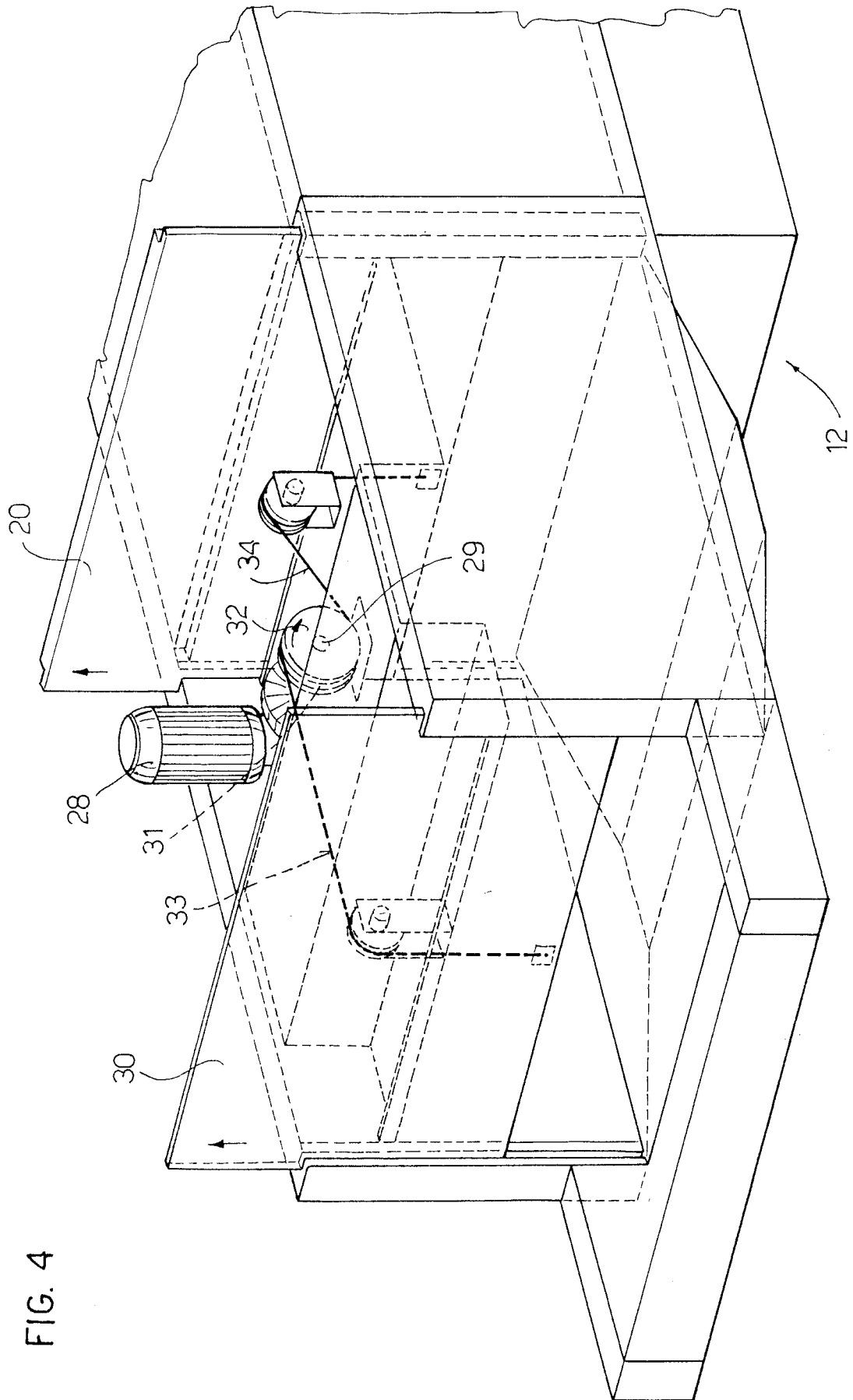

FIG. 4



European Patent
Office

EUROPEAN SEARCH REPORT

Application Number
EP 94 11 7003

DOCUMENTS CONSIDERED TO BE RELEVANT			
Category	Citation of document with indication, where appropriate, of relevant passages	Relevant to claim	CLASSIFICATION OF THE APPLICATION (Int.Cl.6)
A	EP-A-0 512 691 (BRITISH GAS PLC) * column 6, line 32 - line 39; figure 7 * ---	1,9	A47L15/48
A	DD-A-152 717 (WEGNER, H) * claim; figure 1 * ---	1-11	
A	EP-A-0 048 519 (UNILEVER NV) * abstract * ---	1,2	
A	DE-A-33 37 369 (JAHNSEN, JAKOBUS) * page 10, line 8 - line 20 * ---	1-11	
A	DE-U-78 00 591 (ZANUSSI GRANDI IMPIANTI S.P.A.) -----		
The present search report has been drawn up for all claims			TECHNICAL FIELDS SEARCHED (Int.Cl.6)
			A47L
Place of search	Date of completion of the search	Examiner	
THE HAGUE	17 February 1995	Tamme, H-M	
CATEGORY OF CITED DOCUMENTS		T : theory or principle underlying the invention	
X : particularly relevant if taken alone		E : earlier patent document, but published on, or after the filing date	
Y : particularly relevant if combined with another document of the same category		D : document cited in the application	
A : technological background		L : document cited for other reasons	
O : non-written disclosure		
P : intermediate document		& : member of the same patent family, corresponding document	

EPO FORM 1503 03.82 (P04C01)