



US008039319B2

(12) **United States Patent**  
**Hsieh et al.**

(10) **Patent No.:** **US 8,039,319 B2**

(45) **Date of Patent:** **Oct. 18, 2011**

(54) **METHOD FOR FABRICATING QFN SEMICONDUCTOR PACKAGE**

(56) **References Cited**

(75) Inventors: **Tung-Hsien Hsieh**, Changhua County (TW); **Nan-Cheng Chen**, Hsin-Chu (TW)  
(73) Assignee: **Mediatek Inc.**, Science-Based Industrial Park, Hsin-Chu (TW)  
(\* ) Notice: Subject to any disclaimer, the term of this patent is extended or adjusted under 35 U.S.C. 154(b) by 0 days.

U.S. PATENT DOCUMENTS

6,238,952	B1	5/2001	Lin	
6,258,893	B1	7/2001	Okayama	
6,261,864	B1	7/2001	Jung	
6,306,685	B1	10/2001	Liu	
6,333,252	B1	12/2001	Jung	
6,342,730	B1	1/2002	Jung	
6,495,909	B2	12/2002	Jung	
6,507,115	B1*	1/2003	Hofstee et al.	257/777
6,621,140	B1	9/2003	Gibson	
6,642,627	B2*	11/2003	Song et al.	257/786
6,700,188	B2	3/2004	Lin	
6,861,295	B2	3/2005	Jung	
6,906,414	B2	6/2005	Zhao	
7,060,535	B1*	6/2006	Sirinorakul et al.	438/123
7,307,347	B2	12/2007	Yagi	
7,361,984	B2*	4/2008	Wu et al.	257/698
7,471,034	B2*	12/2008	Schlote-Holubek et al.	310/348
2004/0178483	A1*	9/2004	Hsu et al.	257/678

(21) Appl. No.: **12/840,308**

(22) Filed: **Jul. 21, 2010**

(65) **Prior Publication Data**

US 2010/0285638 A1 Nov. 11, 2010

**Related U.S. Application Data**

(62) Division of application No. 12/390,492, filed on Feb. 22, 2009, now Pat. No. 7,786,557.

(60) Provisional application No. 61/054,172, filed on May 19, 2008.

(51) **Int. Cl.**  
**H01L 21/44** (2006.01)  
**H01L 21/48** (2006.01)  
**H01L 21/50** (2006.01)

(52) **U.S. Cl.** ..... **438/124**; 438/123; 438/126; 257/673; 257/676

(58) **Field of Classification Search** ..... 438/123, 438/124, 125, 126; 257/673, 676, 684, 690, 257/E23.141

See application file for complete search history.

**FOREIGN PATENT DOCUMENTS**

JP 3167872 A 7/1991

\* cited by examiner

*Primary Examiner* — Phuc Dang

(74) *Attorney, Agent, or Firm* — Winston Hsu; Scott Margo

(57) **ABSTRACT**

A method for making a quad flat non-lead (QFN) semiconductor package includes half etching a first side of a carrier to form top portions of a lead array and a die attach surface of a die attach pad, wherein the lead array includes at least one inner terminal lead disposed adjacent to the die attach pad, at least one extended, outer terminal lead disposed along periphery of the QFN semiconductor package, and at least one intermediary terminal disposed between the inner terminal lead and the extended, outer terminal lead, wherein the intermediary terminal is disposed between the inner terminal lead and the extended, outer terminal lead.

**11 Claims, 12 Drawing Sheets**

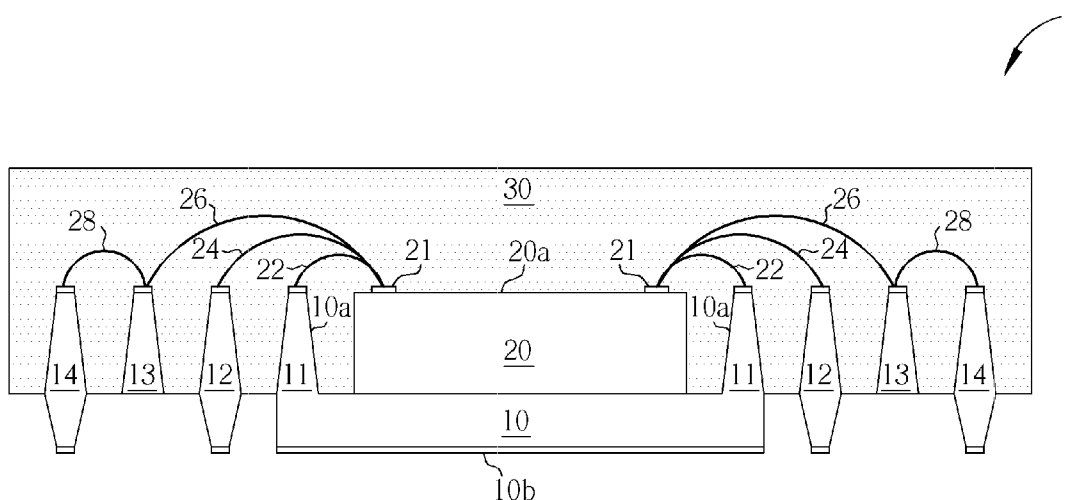

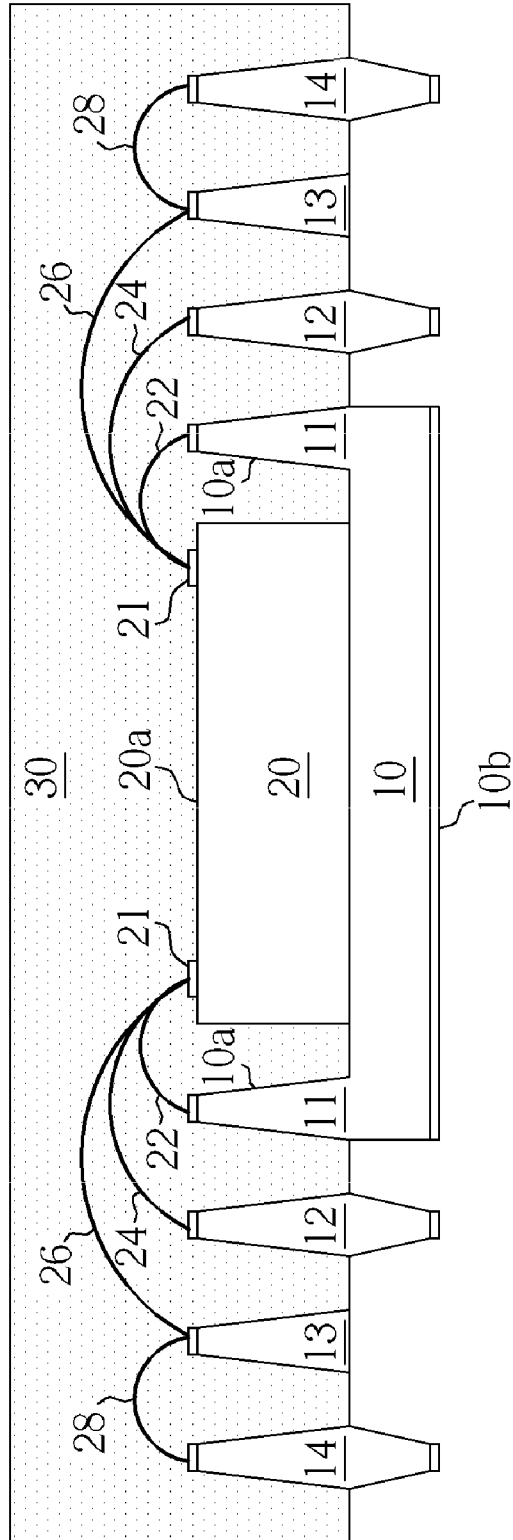

FIG. 1

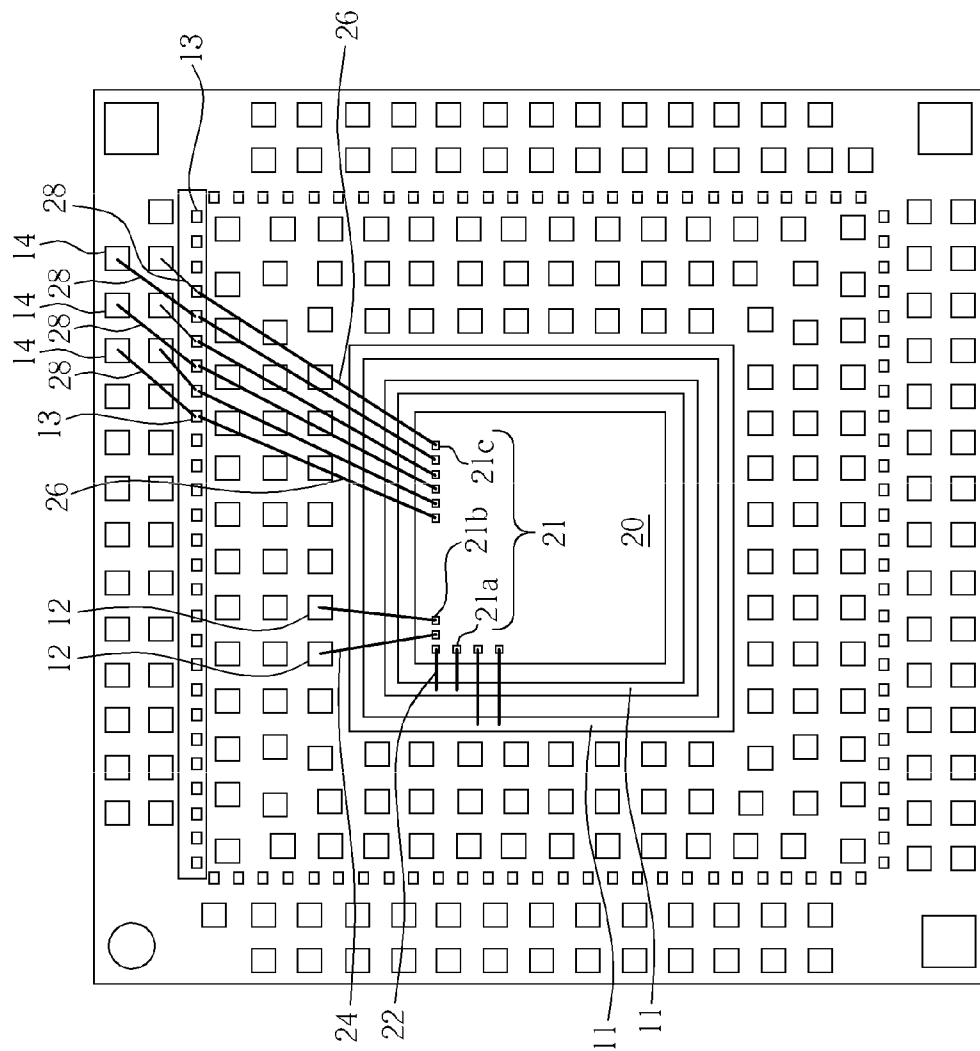

FIG. 2

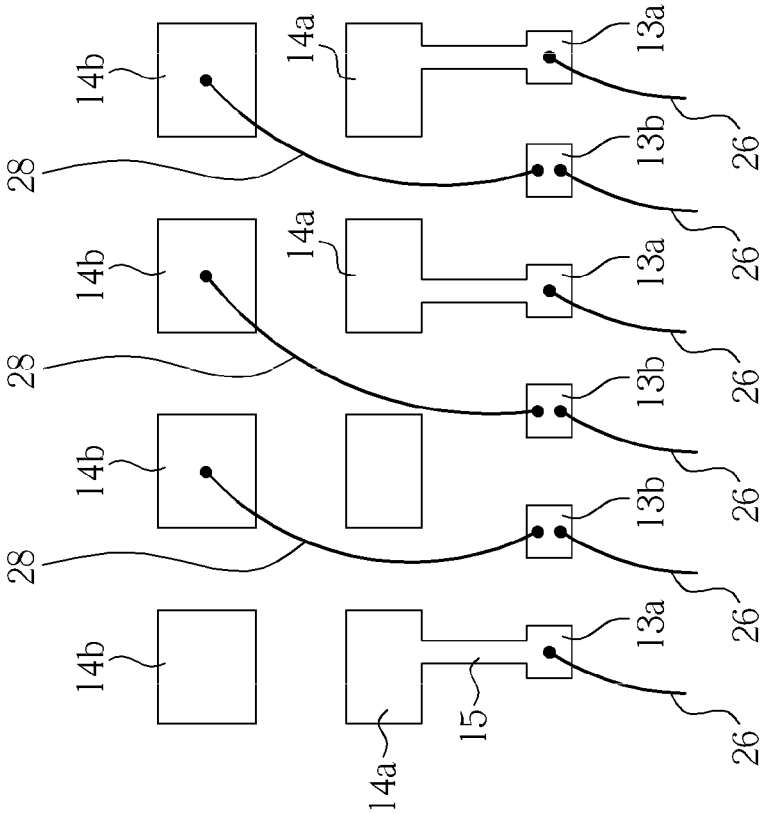

FIG. 3

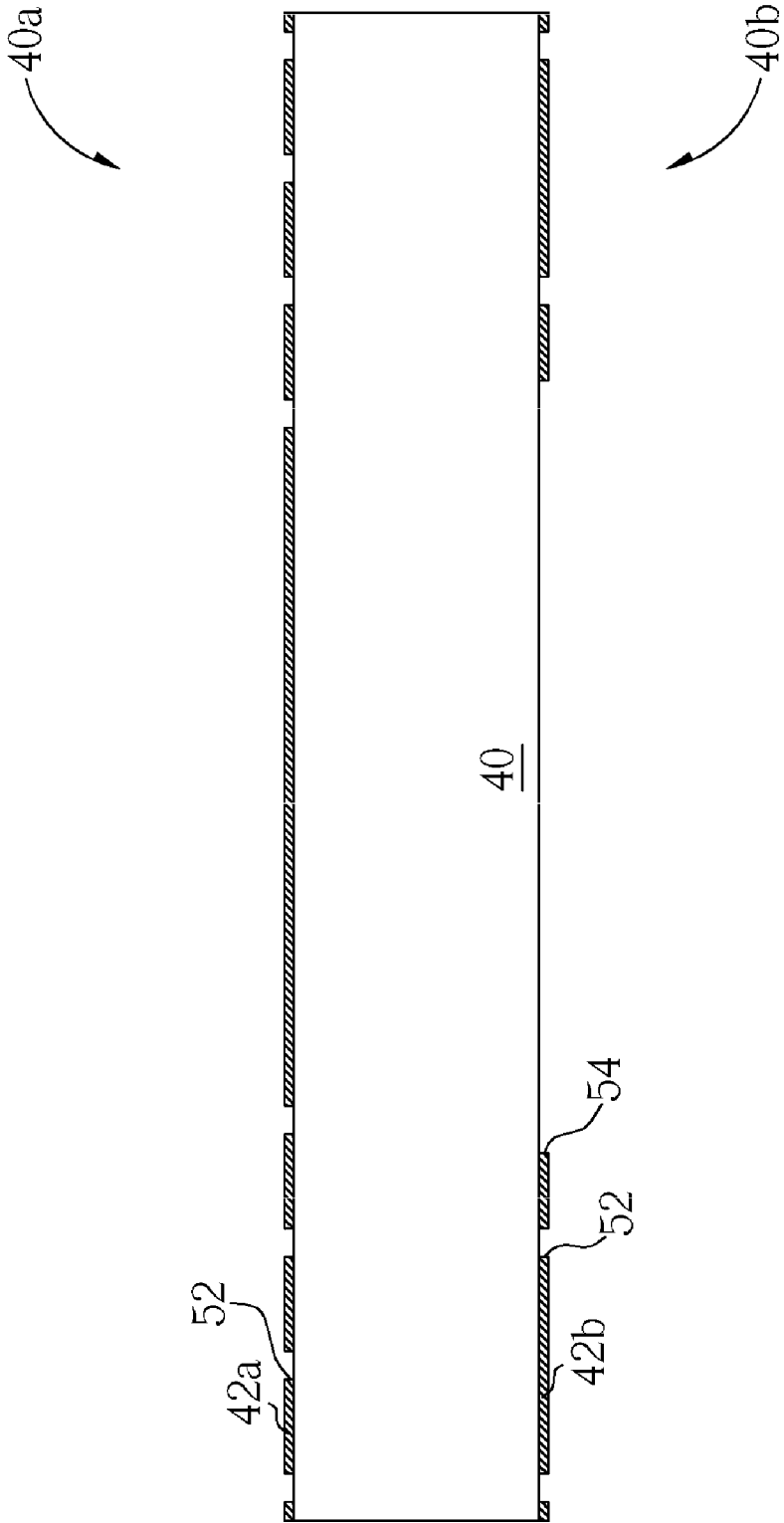

FIG. 4

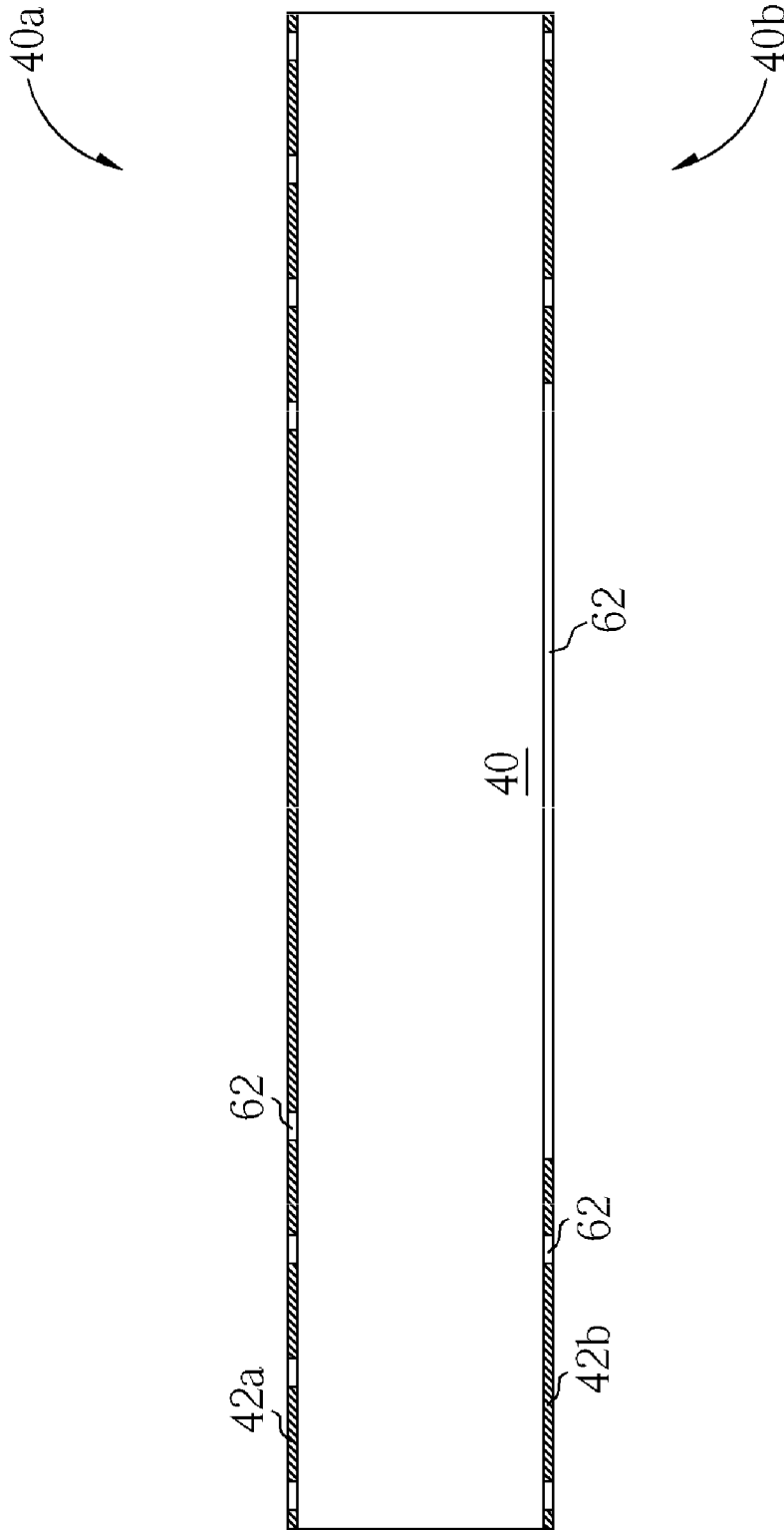

FIG. 5

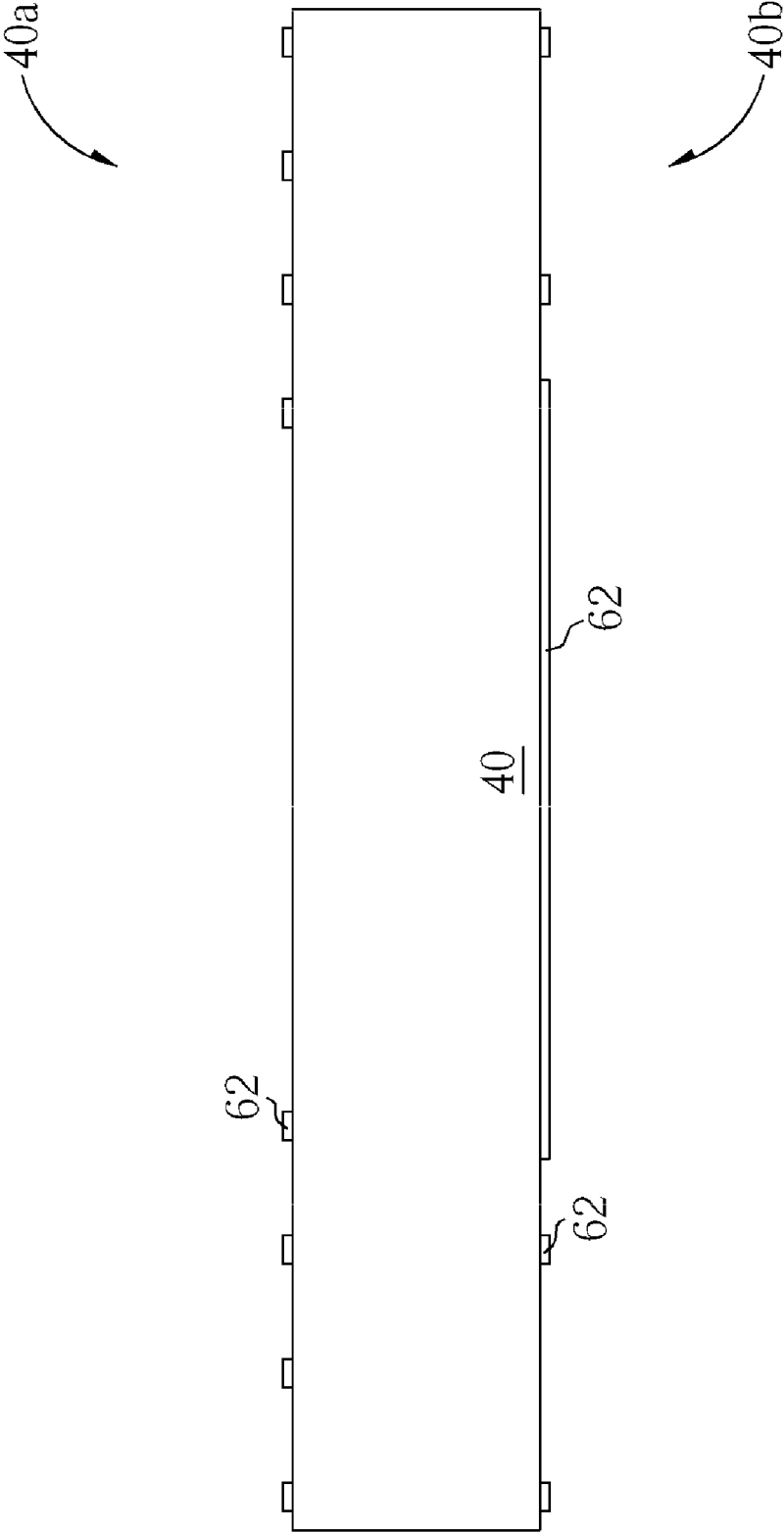

FIG. 6

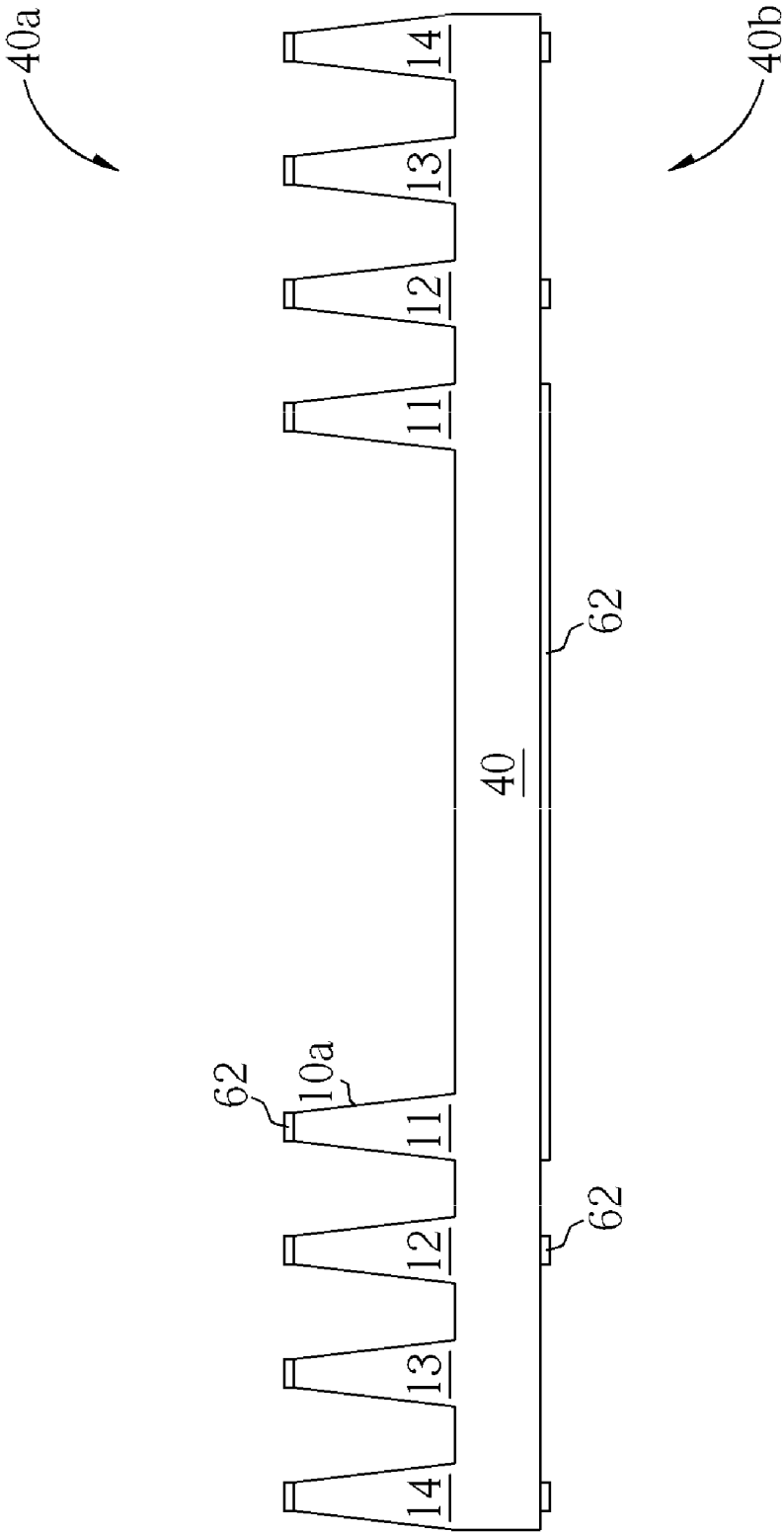

FIG. 7

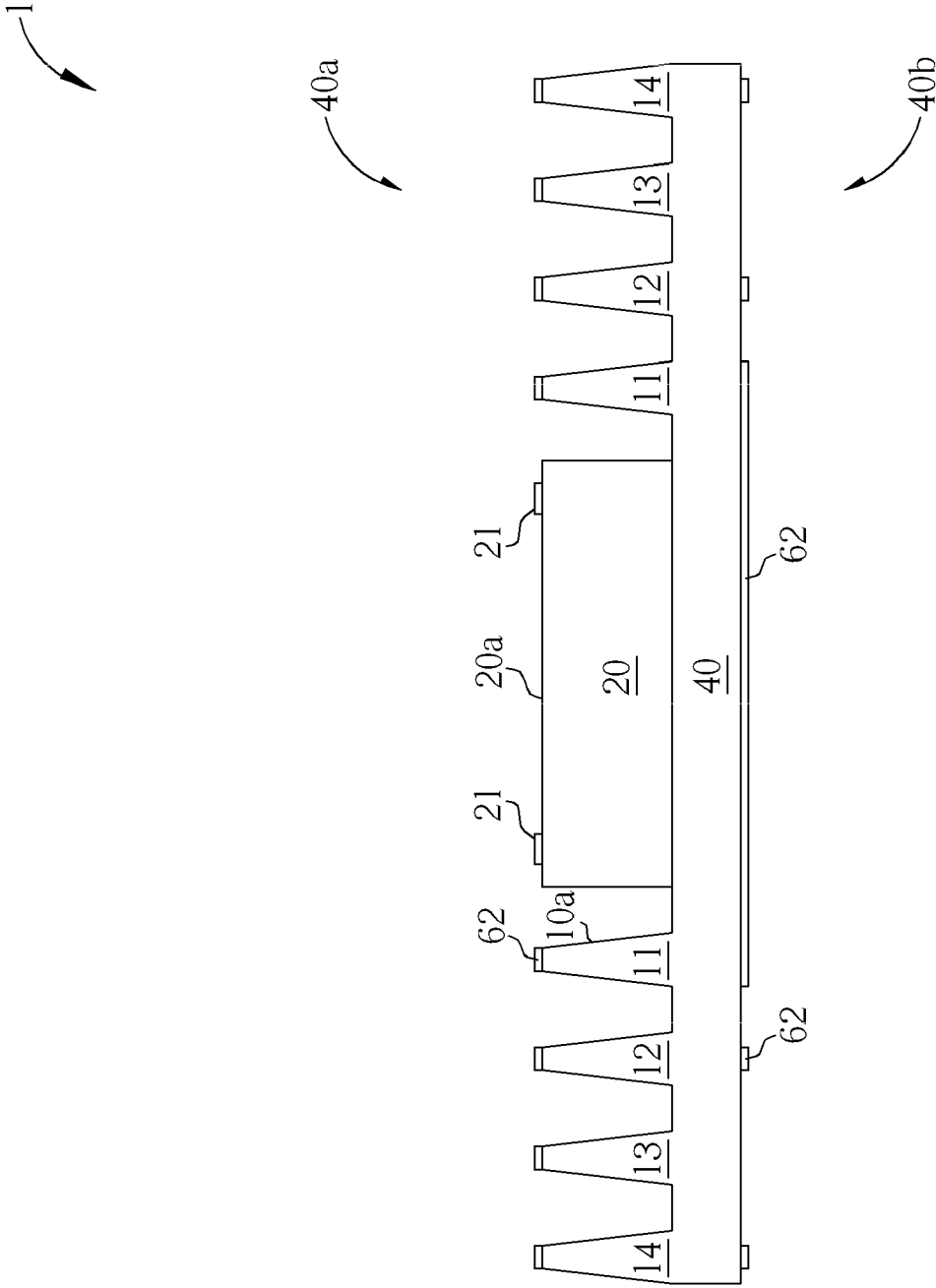

FIG. 8

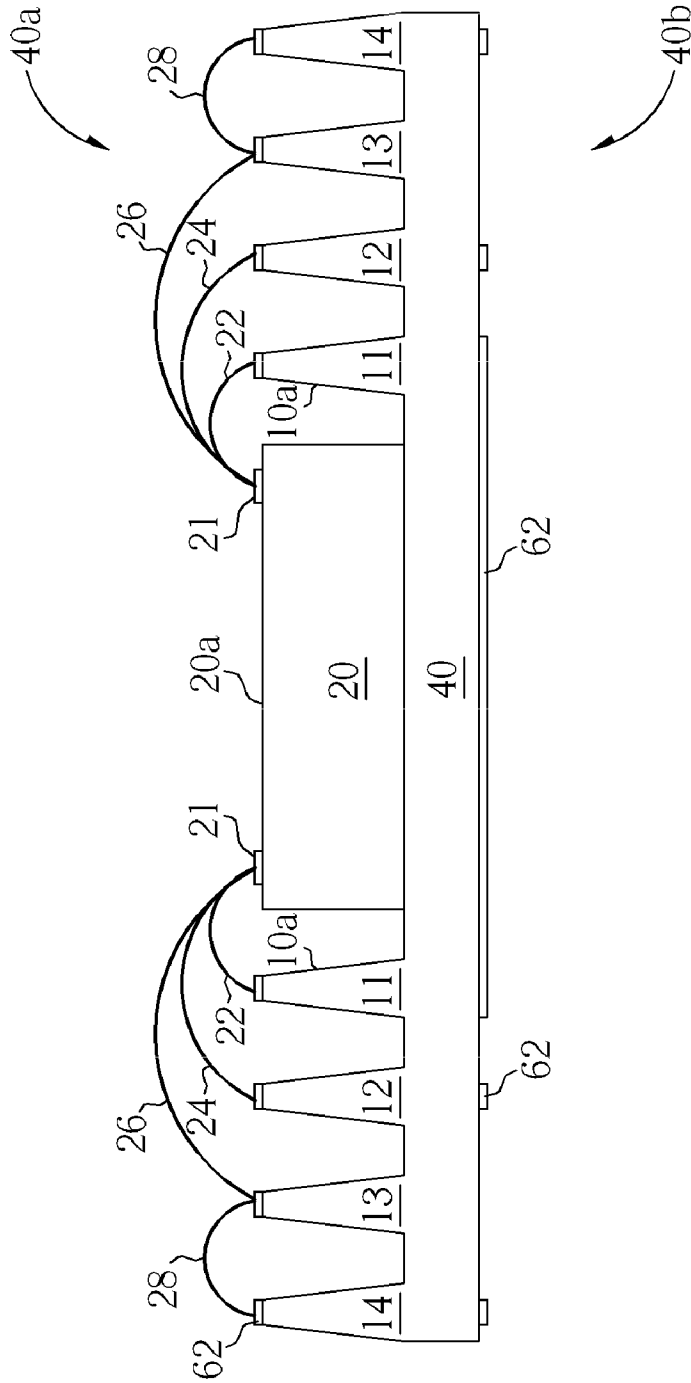

FIG. 9



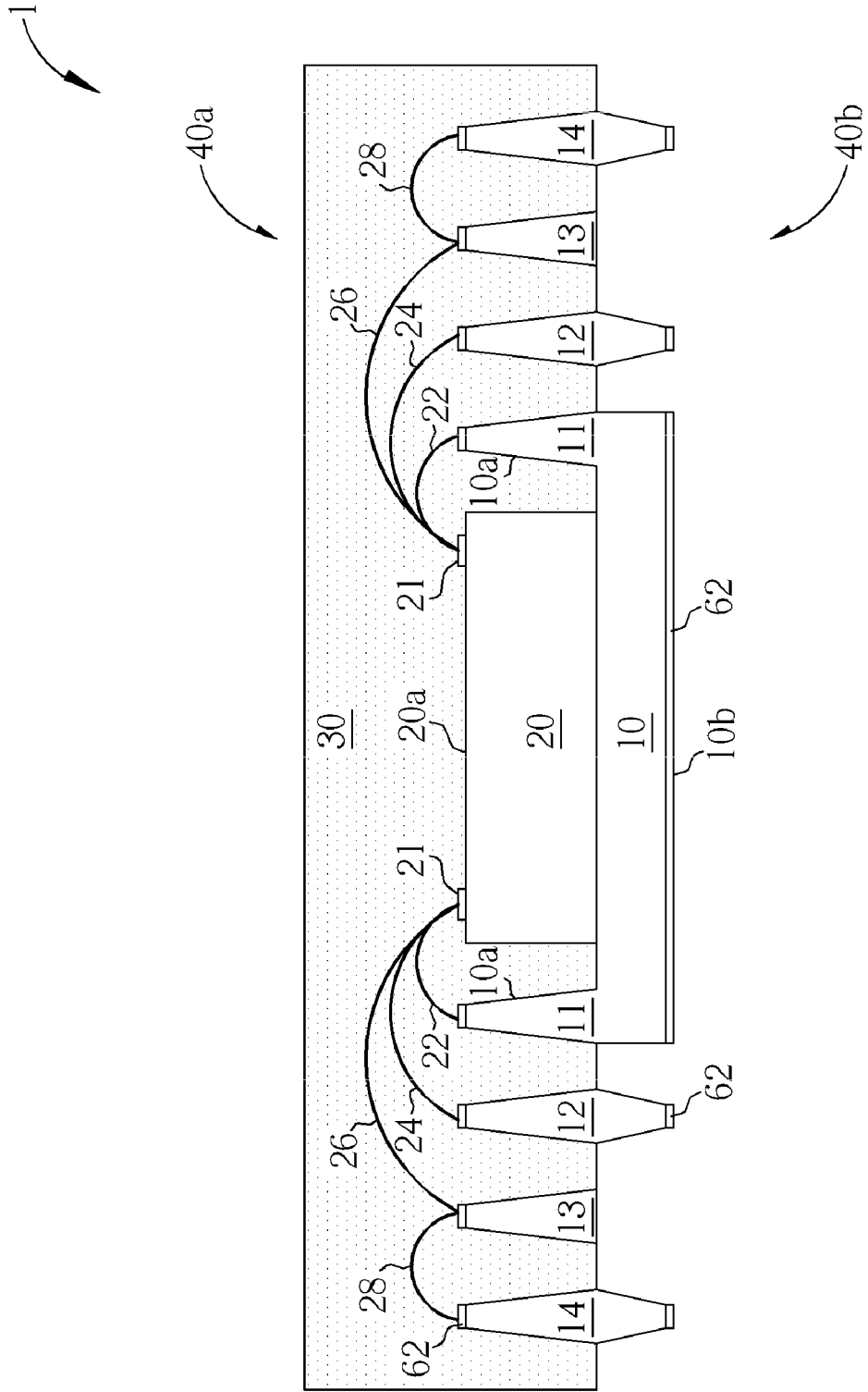

FIG. 11



## METHOD FOR FABRICATING QFN SEMICONDUCTOR PACKAGE

### CROSS REFERENCE TO RELATED APPLICATIONS

This is a divisional of U.S. application Ser. No. 12/390,492 filed Feb. 22, 2009, now U.S. Pat. No. 7,786,557, which claims the benefit of U.S. provisional application Ser. No. 61/054,172 filed May 19, 2008, which is hereby incorporated by reference.

### BACKGROUND OF THE INVENTION

#### 1. Field of the Invention

The present invention relates generally to the field of chip packaging and, more particularly, to a high-pin-count quad flat non-leaded (QFN) semiconductor package having extended terminal leads and fabrication method thereof.

#### 2. Description of the Prior Art

The handheld consumer market is aggressive in the miniaturization of electronic products. Driven primarily by the cellular phone and digital assistant markets, manufacturers of these devices are challenged by ever shrinking formats and the demand for more PC-like functionality. Additional functionality can only be achieved with higher performing logic IC's accompanied by increased memory capability. This challenge, combined together in a smaller PC board format, asserts pressure on surface mount component manufacturers to design their products to command the smallest area possible.

Many of the components used extensively in today's handheld market are beginning to migrate from traditional leaded frame designs to non-leaded formats. The primary driver for handheld manufacturers is the saved PC board space created by these components' smaller mounting areas. In addition, most components also have reductions in weight and height, as well as an improved electrical performance. As critical chip scale packages are converted to non-leaded designs, the additional space saved can be allocated to new components for added device functionality. Since non-leaded designs can use many existing leadframe processes, costs to convert a production line can be minimized.

Similar to leaded components, nonleaded designs use wire bond as the primary interconnection between the IC and the frame. However, due to the unique land site geometry and form factor density, traditional wire bond processes may not produce high yielding production. For these designs, additional wire bond capabilities and alternate processes are needed to produce acceptable production yields.

U.S. Pat. No. 6,238,952 discloses a low-pin-count chip package including a die pad for receiving a semiconductor chip and a plurality of connection pads electrically coupled to the semiconductor chip wherein the die pad and the connection pads have a concave profile. A package body is formed over the semiconductor chip, the die pad and the connection pads in a manner that a portion of the die pad and a portion of each connection pad extend outward from the bottom of the package body.

U.S. Pat. No. 6,261,864 discloses a chip package. The semiconductor chip, the die pad, and the connection pads are encapsulated in a package body such that the lower surfaces of the die pad and the connection pads are exposed through the package body. The die pad and the connection pads are formed by etching such that they have a concave profile and a thickness far larger than that of conventional die pad and connection pads formed by plating.

U.S. Pat. No. 6,306,685 discloses a method of molding a bump chip carrier. Dry films are applied to the top and bottom surface of a copper base plate having a suitable thickness. A circuit pattern is formed on each one of the dry films. Metals are plated onto each of the circuit patterns to form connection pads and an exothermic passage. A die is mounted on the copper base plate. The surfaces of the copper base plate on which the die is mounted are molded to form a molding layer.

U.S. Pat. No. 6,342,730 discloses a package structure including a die pad for receiving a semiconductor chip and a plurality of connection pads electrically coupled to the semiconductor chip. The semiconductor chip, the die pad, and the connection pads are encapsulated in a package body such that the lower surfaces of the die pad and the connection pads are exposed through the package body. The die pad and the connection pads have a substantially concave profile.

U.S. Pat. No. 6,495,909 discloses a chip package. The semiconductor chip, the die pad, and the connection pads are encapsulated by a package body in a manner that the lower surfaces of the die pad and the connection pads are exposed through the package body. The die pad and the connection pads have a T-shaped profile thereby prolonging the time for moisture diffusion into the package.

U.S. Pat. No. 6,621,140 discloses a semiconductor package with inductive segments integrally formed in the leadframe. The inductive segments may be connected directly to a lead of the leadframe, or indirectly to a lead or a bond pad on a semiconductor die via wirebonds to form an inductor.

### SUMMARY OF THE INVENTION

It is one objective to provide a high-pin-count quad flat non-leaded (QFN) semiconductor package having extended terminal leads and fabrication method thereof.

According to one embodiment of this invention, a quad flat non-lead (QFN) semiconductor package includes a die attach pad having a recessed area; a semiconductor die mounted inside the recessed area of the die attach pad, the die attach pad having an exposed bottom surface; at least one row of inner terminal leads disposed adjacent to the die attach pad; first wires bonding respectively the inner terminal leads to the semiconductor die; at least one row of extended, outer terminal leads disposed along periphery of the QFN semiconductor package; at least one row of intermediary terminals disposed between the inner terminal leads and the extended, outer terminal leads; second wires bonding respective the intermediary terminals to the semiconductor die; and third wires bonding respective the intermediary terminals to the extended, outer terminal leads.

In one aspect, a QFN semiconductor package includes a die attach pad having a recessed area; a semiconductor die mounted inside the recessed area of the die attach pad; at least one row of inner terminal leads disposed adjacent to the die attach pad; first wires bonding respective the inner terminal leads to the semiconductor die; at least one row of extended, outer terminal leads disposed along periphery of the QFN semiconductor package; at least one row of intermediary terminals disposed between the inner terminal leads and the extended, outer terminal leads; second wires bonding respective the intermediary terminals to the semiconductor die; and a trace interconnecting one of the intermediary terminals to one of the extended, outer terminal leads.

In another aspect, a method for making a quad flat non-lead (QFN) semiconductor package includes half etching a first side of a carrier to form top portions of a lead array and a die attach surface of a die attach pad, wherein the lead array includes at least one inner terminal lead disposed adjacent to

the die attach pad, at least one extended, outer terminal lead disposed along periphery of the QFN semiconductor package, and at least one intermediary terminal disposed between the inner terminal lead and the extended, outer terminal lead, wherein the intermediary terminal is disposed between the inner terminal lead and the extended, outer terminal lead, wherein the extended, outer terminal lead is disposed beyond a maximum wire length that a wire bonder can provide for a specific minimum pad opening size on the semiconductor die; mounting a semiconductor die on the die attach surface; electrically interconnecting the semiconductor die with the intermediary terminal through a first conductive wire; electrically interconnecting the intermediary terminal with the extended, outer terminal lead through a second conductive wire; encapsulating the semiconductor die, the first and second conductive wires with a mold cap; and half etching a second side of the carrier opposite to the first side to form bottom portions of the lead array and the die attach pad.

In another aspect, a method for making a quad flat non-lead (QFN) semiconductor package includes half etching a first side of a carrier to form top portions of a lead array and a die attach surface of a die attach pad, wherein the lead array includes at least one inner terminal lead disposed adjacent to the die attach pad, at least one extended, outer terminal lead disposed along periphery of the QFN semiconductor package, and at least one intermediary terminal disposed between the inner terminal lead and the extended, outer terminal lead, wherein the intermediary terminal is disposed between the inner terminal lead and the extended, outer terminal lead, wherein the intermediary terminal occupies a smaller bonding surface area than that of the extended, outer terminal lead; mounting a semiconductor die on the die attach surface; electrically interconnecting the semiconductor die with the inner terminal lead and the intermediary terminal through a first conductive wire; electrically interconnecting the intermediary terminal with the extended, outer terminal lead through a second conductive wire; encapsulating the semiconductor die, the first and second conductive wires with a mold cap; and half etching a second side of the carrier opposite to the first side to form bottom portions of the lead array and the die attach pad.

In still another aspect, a method for making a quad flat non-lead (QFN) semiconductor package includes half etching a first side of a carrier to form top portions of a lead array and a die attach surface of a die attach pad, wherein the lead array includes at least one inner terminal lead disposed adjacent to the die attach pad, at least one extended, outer terminal lead disposed along periphery of the QFN semiconductor package, and at least one intermediary terminal disposed between the inner terminal lead and the extended, outer terminal lead, wherein the intermediary terminal is disposed between the inner terminal lead and the extended, outer terminal lead, wherein the intermediary terminal has a recessed bottom surface that is not coplanar with a bottom bonding surface of each of the inner terminal lead and the extended, outer terminal lead; mounting a semiconductor die on the die attach surface; electrically interconnecting the semiconductor die with the inner terminal lead and the intermediary terminal through a first conductive wire; electrically interconnecting the intermediary terminal with the extended, outer terminal lead through a second conductive wire; encapsulating the semiconductor die, the first and second conductive wires with a mold cap; and half etching a second side of the carrier opposite to the first side to form bottom portions of the lead array and the die attach pad.

In still another aspect, a method for making a quad flat non-lead (QFN) semiconductor package includes half etch-

ing a first side of a carrier to form top portions of a lead array and a die attach surface of a die attach pad, wherein the lead array includes at least one inner terminal lead disposed adjacent to the die attach pad, at least one extended, outer terminal lead disposed along periphery of the QFN semiconductor package, and at least one intermediary terminal disposed between the inner terminal lead and the extended, outer terminal lead, wherein the intermediary terminal is disposed between the inner terminal lead and the extended, outer terminal lead, wherein the intermediary terminal occupies a bonding surface area substantially equal to that of the extended, outer terminal lead; mounting a semiconductor die on the die attach surface; electrically interconnecting the semiconductor die with the inner terminal lead and the intermediary terminal through a first conductive wire; electrically interconnecting the intermediary terminal with the extended, outer terminal lead through a second conductive wire; encapsulating the semiconductor die, the first and second conductive wires with a mold cap; and half etching a second side of the carrier opposite to the first side to form bottom portions of the lead array and the die attach pad.

These and other objectives of the present invention will no doubt become obvious to those of ordinary skill in the art after reading the following detailed description of the preferred embodiment that is illustrated in the various figures and drawings.

#### BRIEF DESCRIPTION OF THE DRAWINGS

FIG. 1 is a schematic, cross-sectional diagram illustrating a quad flat non-lead (QFN) semiconductor package with intermediary terminals in accordance with one embodiment of this invention.

FIG. 2 is a top view of the exemplary layout of the QFN semiconductor package with intermediary terminals in accordance with the embodiment of this invention.

FIG. 3 is a schematic, enlarged top view showing the interconnection between the outer terminal leads and the intermediary terminals in accordance with another embodiment of this invention.

FIG. 4 to FIG. 11 are schematic, cross-sectional diagrams showing an exemplary method for making the QFN semiconductor package of FIG. 1.

FIG. 12 is a schematic, cross-sectional diagram illustrating a QFN semiconductor package with intermediary terminals in accordance with still another embodiment of this invention.

#### DETAILED DESCRIPTION

Please refer to FIG. 1 and FIG. 2. FIG. 1 is a schematic, cross-sectional diagram illustrating a quad flat non-lead (QFN) semiconductor package with intermediary terminals in accordance with one embodiment of this invention. FIG. 2 is a top view of the exemplary layout of the QFN semiconductor package with intermediary terminals in accordance with the embodiment of this invention. As shown in FIG. 1 and FIG. 2, the QFN semiconductor package 1 includes a die attach pad 10 having a recessed area 10a. A semiconductor die 20 is mounted inside the recessed area 10a of the die attach pad 10. The die attach pad 10 has a bottom surface 10b that is exposed within the mold cap 30. The die attach pad 10 may comprise a power or ground ring 11. At least one row of inner terminal leads 12 is disposed adjacent to the die attach pad 10. At least one row of extended, outer terminal leads 14 is disposed along the periphery of the QFN semiconductor package 1. At least one row of intermediary terminals 13 is disposed between the inner terminal leads 12 and the

5

extended, outer terminal leads **14**. According to another embodiment of this invention, the die attach pad **10** may be omitted.

The semiconductor die **20** has a top surface **20a** with a plurality of bonding pads **21** including bonding pads **21a**, **21b** and **21c**. The bonding pads **21a** on the semiconductor die **20** are wire bonded to the power or ground ring **11** through the gold wires **22**. The bonding pads **21b** on the semiconductor die **20** are wire bonded to the inner terminal leads **12** through the gold wires **24**. The bonding pads **21c** on the semiconductor die **20** are wire bonded to the intermediary terminals **13** through the gold wires **26**.

According to this embodiment, the outer terminal leads **14** are disposed beyond the maximum wire length that a wire bonding tool or wire bonder can provide for a specific minimum pad opening size. It is known that the maximum wire length that a wire bonder can provide depends upon the minimum pad opening size of the bonding pads on the die.

For example, for the bonding pads **21** having a minimum pad opening size of 43 micrometers, a typical wire bonder can only provide a maximum wire length of 140 mils (3556 micrometers). According to the exemplary embodiment of this invention, the gold wires **26** have the maximum wire length that a wire bonding tool or wire bonder can provide for a specific minimum pad opening size. In order to electrically interconnect the bonding pads **21c** with the outer terminal leads **14**, the intermediary terminals **13** are wire bonded to the corresponding outer terminal leads **14** through gold wires **28**.

It is understood that the arrangement or layout of the single row of the intermediary terminals **13** is merely exemplary and should not be used to limit the scope of this invention. In another case, the intermediary terminals **13** may be arranged in two or more rows, or may be arranged alternately in two rows. According to this embodiment, each of the intermediary terminals **13** could occupy a smaller bonding surface area than each of the outer terminal leads **14** that has a bonding surface area substantially equal to each of the inner terminal leads **12**.

The smaller intermediary terminals **13** are best seen in FIG. 2. For example, each of the inner terminal leads **12** and the outer terminal leads **14** has a dimension of 270  $\mu\text{m}$   $\times$  270  $\mu\text{m}$ , and each of the intermediary terminals **13** has a dimension of 150  $\mu\text{m}$   $\times$  150  $\mu\text{m}$ . It is to be understood that the bonding surface area of each of the intermediary terminals **13** must be adequate to accommodate two squash balls (not explicitly shown) of the two gold wires **26** and **28**.

FIG. 3 is a schematic, enlarged top view showing the interconnection between the outer terminal leads and the intermediary terminals in accordance with another embodiment of this invention. As shown in FIG. 3, the outer terminal lead **14a** in a first row is electrically interconnected to the intermediary terminal **13a** through a trace **15**, while the outer terminal lead **14b** in a farther second row is electrically interconnected to the intermediary terminal **13a** through the gold wire **28**.

FIG. 4 to FIG. 11 are schematic, cross-sectional diagrams showing an exemplary method for making the QFN semiconductor package **1** with intermediary terminals of FIG. 1, wherein like numeral numbers designate like regions, layers or elements. As shown in FIG. 4, a copper carrier **40** is provided. A patterned photoresist film **42a** and a patterned photoresist film **42b** are formed respectively on the opposite first and second sides **40a** and **40b** of the copper carrier **40** for defining lead array patterns **52** and a die attach pad pattern **54** thereon.

As shown in FIG. 5, a plating process is carried out to fill the lead array patterns **52** and the die attach pad pattern **54** on the two opposite sides of the copper carrier **40** with a bond-

6

able metal layer **62** such as nickel, gold or combination thereof. As shown in FIG. 6, the patterned photoresist film **42a** and the patterned photoresist film **42b** are stripped off to expose a portion of the surface of the copper carrier **40**.

As shown in FIG. 7, subsequently, a copper etching process is performed to half etch the exposed portion of the copper carrier **40** from the first side **40a**. A recessed area **10a** is formed on the first side **40a**. During the copper etching process, the bondable metal layer **62** acts as an etching hard mask. According to this embodiment, the steps described through FIG. 4 to FIG. 7 may be performed in a leadframe manufacturing factory.

As shown in FIG. 8, a semiconductor die **20** is mounted inside the recessed area **10a**, for example, by surface mount technology (SMT) or any other suitable methods. The semiconductor die **20** has a top surface **20a** with a plurality of bonding pads, which are not explicitly shown.

As shown in FIG. 9, a wire bonding process is carried out to electrically interconnect the bonding pads on the top surface **20a** of the semiconductor die **20** with the corresponding terminal leads through gold wires **22**, **24**, **26** and **28** respectively. As previously mentioned, the maximum wire length that a wire bonder can provide in the wire bonding process depends upon the minimum pad opening size of the bonding pads on the semiconductor die **20**. For example, for the bonding pads having minimum pad opening size of 43 micrometers, a typical wire bonder can only provide a maximum wire length of 140 mils (3556 micrometers). According to this embodiment, the gold wires **26** have the maximum wire length that a wire bonding tool or wire bonder can provide for a specific minimum pad opening size.

As shown in FIG. 10, a molding process is performed. The semiconductor die **20**, gold wires **22**, **24**, **26** and **28**, and the first side **40a** of the copper carrier **40** is encapsulated within a mold cap **30** such as epoxy resins.

As shown in FIG. 11, after the molding process, a copper etching process is performed to half etch the exposed copper carrier **40** that is not covered by the bondable metal layer **62** from the second side **40b**, thereby forming die attach pad **10**, power or ground ring **11**, inner terminal leads **12**, intermediary terminals **13** and the outer terminal leads **14**. According to this embodiment, the power or ground ring **11** is integrally formed with the die attach pad **10** and is annular-shaped. The power or ground ring **11** may be continuous or discontinuous. The die attach pad **10**, the inner terminal leads **12** and the outer terminal leads **14** have exposed bottom surfaces **10b**, **12b** and **14b** respectively, which are substantially coplanar. The exposed bottom surfaces **10b**, **12b** and **14b** of the die attach pad **10**, the inner terminal leads **12** and the outer terminal leads **14** respectively are eventually bonded to a printed circuit board. The intermediary terminal **13** has a recessed bottom surface **13b** that is not coplanar with any of the exposed bottom surfaces **10b**, **12b** and **14b**. According to this embodiment, the steps described through FIG. 8 to FIG. 11 may be performed in an assembly or packaging house.

FIG. 12 is a schematic, cross-sectional diagram illustrating a QFN semiconductor package with intermediary terminals in accordance with still another embodiment of this invention. As shown in FIG. 12, the difference between the QFN semiconductor package **1** of FIG. 1 and the QFN semiconductor package **1a** of FIG. 12 is that in FIG. 12 the bottom surface **13b** of the intermediary terminal **13** is covered with a protection layer **70** such as glue or any suitable insulating materials for avoiding shorting with the printed circuit board.

Those skilled in the art will readily observe that numerous modifications and alterations of the device and method may be made while retaining the teachings of the invention. Accordingly, the above disclosure should be construed as limited only by the metes and bounds of the appended claims.

What is claimed is:

1. A method for making a quad flat non-lead (QFN) semiconductor package, comprising:

half etching a first side of a carrier to form top portions of a lead array and a die attach surface of a die attach pad, wherein the lead array includes at least one inner terminal lead disposed adjacent to the die attach pad, at least one extended, outer terminal lead disposed along periphery of the QFN semiconductor package, and at least one intermediary terminal disposed between the inner terminal lead and the extended, outer terminal lead, wherein the intermediary terminal is disposed between the inner terminal lead and the extended, outer terminal lead, wherein the extended, outer terminal lead is disposed beyond a maximum wire length that a wire bonder can provide for a specific minimum pad opening size on the semiconductor die;

mounting a semiconductor die on the die attach surface; electrically interconnecting the semiconductor die with the intermediary terminal through a first conductive wire; electrically interconnecting the intermediary terminal with the extended, outer terminal lead through a second conductive wire;

encapsulating the semiconductor die, the first and second conductive wires with a mold cap; and

half etching a second side of the carrier opposite to the first side to form bottom portions of the lead array and the die attach pad.

2. The method according to claim 1 wherein the specific minimum pad opening size is 43 micrometers and the maximum wire length is 140 mils.

3. The method according to claim 1 wherein the intermediary terminal occupies a smaller bonding surface area than that of the extended, outer terminal lead.

4. The method according to claim 1 wherein the intermediary terminal has a recessed bottom surface that is not coplanar with a bottom bonding surface of the inner terminal lead and the extended, outer terminal lead.

5. The method according to claim 4 wherein the recessed bottom surface is covered with a protection layer.

6. A method for making a quad flat non-lead (QFN) semiconductor package, comprising:

half etching a first side of a carrier to form top portions of a lead array and a die attach surface of a die attach pad, wherein the lead array includes at least one inner terminal lead disposed adjacent to the die attach pad, at least one extended, outer terminal lead disposed along periphery of the QFN semiconductor package, and at least one intermediary terminal disposed between the inner terminal lead and the extended, outer terminal lead, wherein the intermediary terminal is disposed between the inner terminal lead and the extended, outer terminal lead, wherein the intermediary terminal occupies a smaller bonding surface area than that of the extended, outer terminal lead, wherein the intermediary terminal has a recessed bottom surface covered with a protection layer;

mounting a semiconductor die on the die attach surface; electrically interconnecting the semiconductor die with the inner terminal lead and the intermediary terminal through a first conductive wire;

electrically interconnecting the intermediary terminal with the extended, outer terminal lead through a second conductive wire;

encapsulating the semiconductor die, the first and second conductive wires with a mold cap; and

half etching a second side of the carrier opposite to the first side to form bottom portions of the lead array and the die attach pad.

7. The method according to claim 6 wherein the recessed bottom surface is not coplanar with a bottom bonding surface

of the inner terminal lead and the extended, outer terminal lead.

8. A method for making a quad flat non-lead (QFN) semiconductor package, comprising:

half etching a first side of a carrier to form top portions of a lead array and a die attach surface of a die attach pad, wherein the lead array includes at least one inner terminal lead disposed adjacent to the die attach pad, at least one extended, outer terminal lead disposed along periphery of the QFN semiconductor package, and at least one intermediary terminal disposed between the inner terminal lead and the extended, outer terminal lead, wherein the intermediary terminal is disposed between the inner terminal lead and the extended, outer terminal lead, wherein the intermediary terminal has a recessed bottom surface that is not coplanar with a bottom bonding surface of each of the inner terminal lead and the extended, outer terminal lead, wherein the recessed bottom surface is covered with a protection layer;

mounting a semiconductor die on the die attach surface; electrically interconnecting the semiconductor die with the inner terminal lead and the intermediary terminal through a first conductive wire;

electrically interconnecting the intermediary terminal with the extended, outer terminal lead through a second conductive wire;

encapsulating the semiconductor die, the first and second conductive wires with a mold cap; and

half etching a second side of the carrier opposite to the first side to form bottom portions of the lead array and the die attach pad.

9. A method for making a quad flat non-lead (QFN) semiconductor package, comprising:

half etching a first side of a carrier to form top portions of a lead array and a die attach surface of a die attach pad, wherein the lead array includes at least one inner terminal lead disposed adjacent to the die attach pad, at least one extended, outer terminal lead disposed along periphery of the QFN semiconductor package, and at least one intermediary terminal disposed between the inner terminal lead and the extended, outer terminal lead, wherein the intermediary terminal is disposed between the inner terminal lead and the extended, outer terminal lead, wherein the intermediary terminal occupies a bonding surface area substantially equal to that of the extended, outer terminal lead, wherein the intermediary terminal has a recessed bottom surface covered with a protection layer;

mounting a semiconductor die on the die attach surface; electrically interconnecting the semiconductor die with the inner terminal lead and the intermediary terminal through a first conductive wire;

electrically interconnecting the intermediary terminal with the extended, outer terminal lead through a second conductive wire;

encapsulating the semiconductor die, the first and second conductive wires with a mold cap; and

half etching a second side of the carrier opposite to the first side to form bottom portions of the lead array and the die attach pad.

10. The QFN semiconductor package according to claim 9 wherein the extended, outer terminal lead is disposed beyond a maximum wire length that a wire bonder can provide for a specific minimum pad opening size on the semiconductor die.

11. The method according to claim 9 wherein the recessed bottom surface is not coplanar with a bottom bonding surface of the inner terminal lead and the extended, outer terminal lead.

UNITED STATES PATENT AND TRADEMARK OFFICE  
**CERTIFICATE OF CORRECTION**

PATENT NO. : 8,039,319 B2  
APPLICATION NO. : 12/840308  
DATED : October 18, 2011  
INVENTOR(S) : Tung-Hsien Hsieh et al.

Page 1 of 1

It is certified that error appears in the above-identified patent and that said Letters Patent is hereby corrected as shown below:

On the title page, correct the continuity type of The Related U.S. Application Data from "Division" to  
--Continuation--.

Signed and Sealed this  
Eighth Day of May, 2012

A handwritten signature in black ink that reads "David J. Kappos". The signature is written in a cursive, slightly slanted style.

David J. Kappos  
*Director of the United States Patent and Trademark Office*