

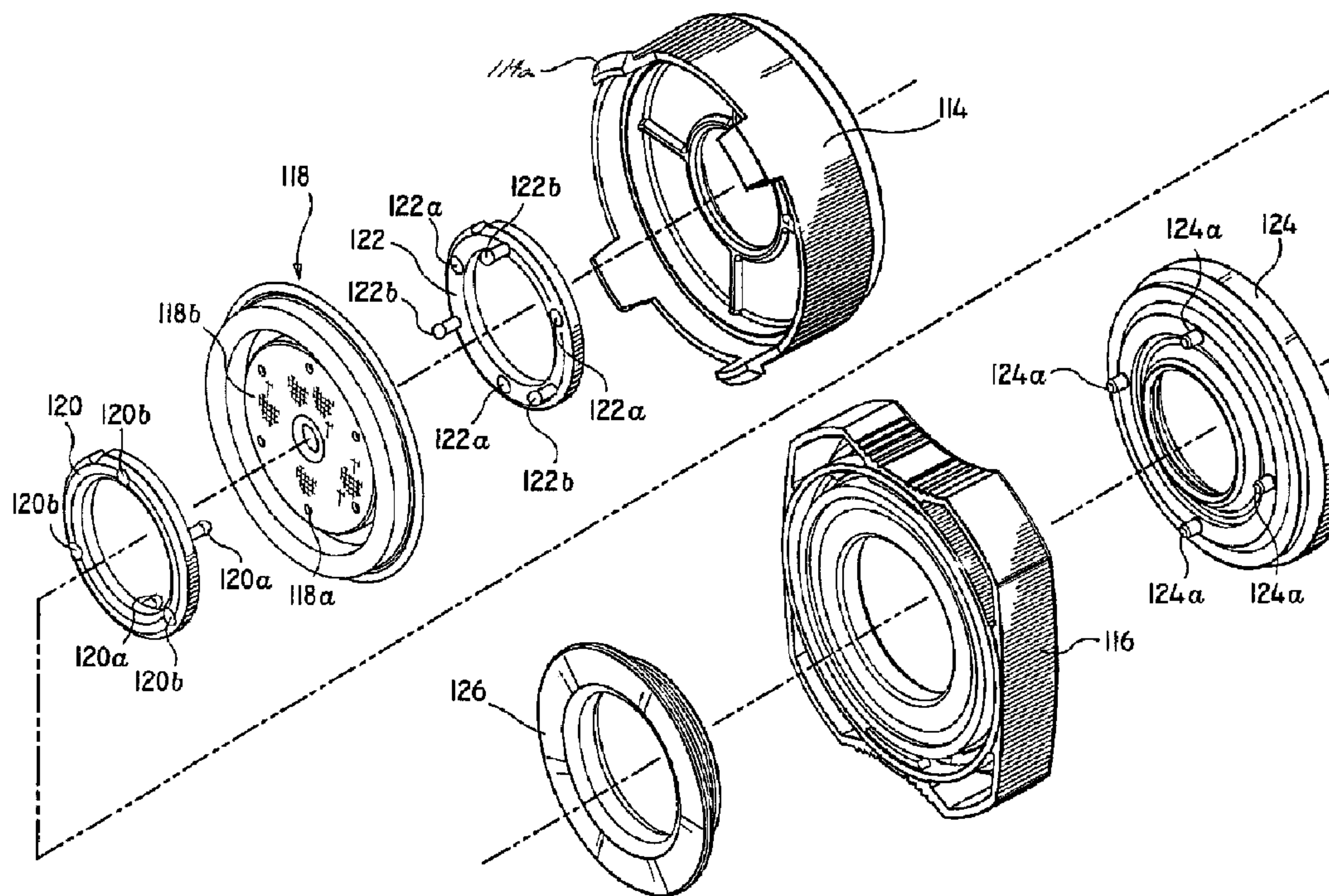

(86) Date de dépôt PCT/PCT Filing Date: 1998/05/01
 (87) Date publication PCT/PCT Publication Date: 1998/11/12
 (45) Date de délivrance/Issue Date: 2006/07/18
 (85) Entrée phase nationale/National Entry: 1999/11/01
 (86) N° demande PCT/PCT Application No.: US 1998/008968
 (87) N° publication PCT/PCT Publication No.: 1998/050093
 (30) Priorité/Priority: 1997/05/02 (US60/045,412)

(51) Cl.Int./Int.Cl. *A61B 17/00* (2006.01),
A61B 17/34 (2006.01), *A61M 39/04* (2006.01)
 (72) Inventeurs/Inventors:
RACENET, DAVID C., US;
STELLON, GENE A., US;
VUMBACK, WILLIAM J., US;
PASQUALUCCI, JOSEPH, US
 (73) Propriétaire/Owner:
TYCO HEALTHCARE GROUP LP, US
 (74) Agent: MCFADDEN, FINCHAM

(54) Titre : SYSTEME DE JOINT POUR TROCART
 (54) Title: TROCAR SEAL SYSTEM



(57) **Abrégé/Abstract:**

A seal assembly (100) for reception of an elongated surgical instrument (110) is provided which includes housing components (114, 116) having at least one opening configured, dimensioned to permit entry of an elongated surgical instrument (110), and defining a central longitudinal axis. The seal assembly (100) further comprises a seal member (118) formed of a resilient material and defining an aperture therein, the aperture being configured and dimensioned such that insertion of the surgical instrument (110) into the aperture causes the resilient material defining the aperture to resiliently contact the outer surface of the surgical instrument (110) in a substantially fluid tight manner; and a fabric layer (128) juxtaposed relative to the resilient material. A coating (418) may be applied to seal member (118) to reduce friction between seal member (118) and surgical instrumentation (110) inserted therein. The coating (418) is preferably a hydro-cyclo-siloxane membrane deposited by plasma polymerization process.



PCT

WORLD INTELLECTUAL PROPERTY ORGANIZATION
International Bureau

INTERNATIONAL APPLICATION PUBLISHED UNDER THE PATENT COOPERATION TREATY (PCT)

<p>(51) International Patent Classification⁶ : A61M 5/00</p>	A1	<p>(11) International Publication Number: WO 98/50093</p> <p>(43) International Publication Date: 12 November 1998 (12.11.98)</p>
<p>(21) International Application Number: PCT/US98/08968</p> <p>(22) International Filing Date: 1 May 1998 (01.05.98)</p> <p>(30) Priority Data: 60/045,412 2 May 1997 (02.05.97) US</p> <p>(71) Applicant (for all designated States except US): UNITED STATES SURGICAL CORPORATION [US/US]; 150 Glover Avenue, Norwalk, CT 06856 (US).</p> <p>(72) Inventors; and (75) Inventors/Applicants (for US only): RACENET, David, C. [US/US]; 1153 Bullet Hill Road, Southbury, CT 06488 (US). STELLON, Gene, A. [US/US]; 368 Savage Street, Southington, CT 06489 (US). VUMBACK, William, J. [US/US]; 40 Sunnyside Drive, Northford, CT 06472 (US). PASQUALUCCI, Joseph [US/US]; 91 Scrub Oak Road, North Haven, CT 06743 (US).</p> <p>(74) Agents: FARRELL, Raymond, E.; Dilworth & Barrese, 333 Earle Ovington Boulevard, Uniondale, NY 11553 (US) et al.</p>		<p>(81) Designated States: AL, AM, AT, AU, AZ, BA, BB, BG, BR, BY, CA, CH, CN, CU, CZ, DE, DK, EE, ES, FI, GB, GE, GH, GM, GW, HU, ID, IL, IS, JP, KE, KG, KP, KR, KZ, LC, LK, LR, LS, LT, LU, LV, MD, MG, MK, MN, MW, MX, NO, NZ, PL, PT, RO, RU, SD, SE, SG, SI, SK, SL, TJ, TM, TR, TT, UA, UG, US, UZ, VN, YU, ZW, ARIPO patent (GH, GM, KE, LS, MW, SD, SZ, UG, ZW), Eurasian patent (AM, AZ, BY, KG, KZ, MD, RU, TJ, TM), European patent (AT, BE, CH, CY, DE, DK, ES, FI, FR, GB, GR, IE, IT, LU, MC, NL, PT, SE), OAPI patent (BF, BJ, CF, CG, CI, CM, GA, GN, ML, MR, NE, SN, TD, TG).</p> <p>Published With international search report.</p>

(54) Title: TROCAR SEAL SYSTEM

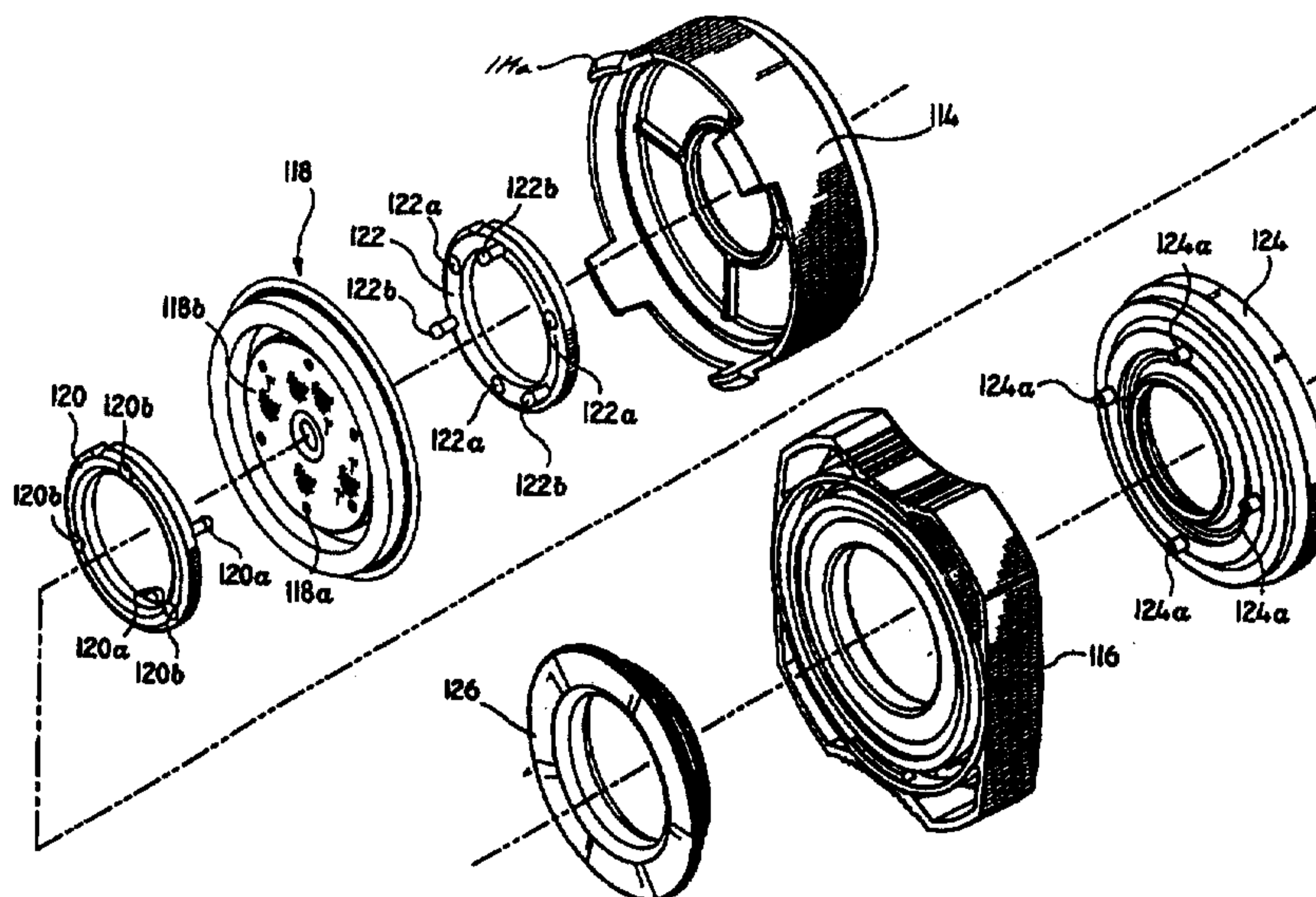

(57) Abstract

A seal assembly (100) for reception of an elongated surgical instrument (110) is provided which includes housing components (114, 116) having at least one opening configured, dimensioned to permit entry of an elongated surgical instrument (110), and defining a central longitudinal axis. The seal assembly (100) further comprises a seal member (118) formed of a resilient material and defining an aperture therein, the aperture being configured and dimensioned such that insertion of the surgical instrument (110) into the aperture causes the resilient material defining the aperture to resiliently contact the outer surface of the surgical instrument (110) in a substantially fluid tight manner; and a fabric layer (120) juxtaposed relative to the resilient material. A coating (122) may be applied to seal member (118) to reduce friction between seal member (118) and surgical instrumentation (110) inserted therein. The coating (122) is preferably a hydro-cyclo-siloxane membrane deposited by plasma polymerization process.

TROCAR SEAL SYSTEMBACKGROUND1. Technical Field

5 The present disclosure relates to seal systems of the type adapted to allow the introduction of a surgical instrument into a patient's body. In particular, the disclosure relates to a seal system to be used in combination with a cannula assembly where the cannula assembly is intended for insertion into a patient's body and an instrument is inserted
10 into the patient's body through the cannula.

2. Background Of Related Art

Laparoscopic procedures are performed in the interior of the abdomen through a small incision, e.g., through narrow endoscopic tubes or cannulas inserted through a small
15 entrance incision in the skin. Minimally invasive procedures are performed elsewhere in the body, e.g., in the chest, and are often generally referred to as "endoscopic" procedures. Minimally invasive or endoscopic procedures generally require that any instrumentation inserted into the body be sealed, i.e.
20 provisions must be made to ensure that gases do not enter or exit the body through the endoscopic incision as, for example, in surgical procedures in which the surgical region is insufflated. Moreover, endoscopic procedures often require the surgeon to act on organs, tissues, and vessels far removed from
25 the incision, thereby requiring that any instruments used in such procedures be relatively long and narrow.

For such procedures, the introduction of a tube into certain anatomical cavities such as the abdominal cavity is usually accomplished by use of a system incorporating a trocar
30 and cannula assembly. A cannula assembly is formed of a cannula

attached to a cannula housing which generally includes seal assembly adapted to maintain a seal across the opening of the seal assembly both with and without an instrument inserted therethrough. Since the cannula is in direct communication with the internal portion of the seal assembly, insertion of the cannula into an opening in the patient's body so as to reach the inner abdominal cavity should be adapted to maintain a fluid tight interface between the abdominal cavity and the outside atmosphere.

Since minimally invasive surgical procedures in the abdominal cavity of the body generally require insufflating gases to raise the cavity wall away from vital organs, the procedure is usually initiated by use of a Verres needle through which a gas is introduced into the body cavity. The gas provides a slight pressure which raises the wall surface of the peritoneum away from the vital organs thereby providing an adequate region in which to operate. Thereafter, a trocar assembly which includes a cannula and a trocar or obturator is inserted within the cannula to puncture the peritoneum, i.e. the inner lining of the abdominal cavity wall. The obturator is removed and laparoscopic or endoscopic surgical instruments may then be inserted through the cannula to perform surgery within the abdominal cavity. The cannula may also be utilized for introducing tubes into the body as for drainage purposes, for specimen removal, for diagnostic evaluations, or the like.

In view of the need to maintain the atmospheric integrity of the inner area of the cavity, a seal assembly for a cannula which permits introduction of an obturator and a wide range of surgical instruments and which maintains the atmospheric integrity of the inner area of the cavity is desirable. Generally, in the context of insufflatory, minimally invasive surgical procedures, cannula assemblies include structure(s) that satisfy two sealing requirements. The first

requirement is to provide a substantially fluid tight seal when an instrument is not present in the cannula. The second requirement is to provide a substantially fluid tight seal when an instrument is being introduced into or already is present in the cannula. In this regard, there have been a number of

5

attempts in the prior art to provide such sealing requirements.

U.S. Patent No. 4,655,752 to Honkanen et al.

teaches a cannula including a housing and first and second seal members. The first seal member is conically tapered toward the bottom of the housing and has a circular opening in its center, while the second seal is conically tapered and cup shaped. The second seal includes at least one slit to allow for the passage of instruments.

10

U.S. Patent No. 4,929,235 to Merry et al. teaches

15

a self-sealing catheter introducer having a sealing mechanism to prevent blood or fluid leakage. The sealing mechanism includes a planar sealing element having a slit and a conical sealing element. The sealing elements are each adapted to surround a tube.

20

U.S. Patent Nos. 4,874,377 and 5,064,416 to

Newgard et al. relate to a self-occluding intravascular cannula assembly in which an elastomeric valving member is positioned transversely to a housing and is peripherally compressed to cause displacement, distortion and/or rheological flow of the elastomeric material. A frustoconical dilator projection cooperates with the elastomeric valving member in moving the valving member to a non-occluding position.

25

U.S. Patent No. 5,300,033 to Miller suggests a

30

valve construction including an elastic body having a cylindrical wall with first and second walls formed integrally with the cylindrical wall. The second wall includes a slit to permit passage of a surgical instrument and first and second leaflets which define the slit. The leaflets are thicker in

cross section to provide an additional closing force at the slit.

A disadvantage of several known seal systems for cannulas concerns the difficulty encountered in inserting and advancing the surgical instrument through the seal unit. In particular, since known elastomeric seal members are designed to form and maintain a fluid tight seal about the instrument, the aperture or slit within the seal through which the instrument is passed is of relatively small or
10 narrow dimension. Further, portions of the seal member defining the aperture are generally thick in cross-section to provide a sufficient closing force of the seal about the instrument, see, e.g., U.S. Patent No. 5,300,033. As a consequence of these design considerations, the level of force needed to insert and advance the instrument through the seal aperture is increased, thereby requiring awkward maneuvering on the surgeon's behalf to appropriately position the instrument for the desired surgery. Moreover, known seal systems are generally ineffectual in
20 accommodating instruments of differing diameter while maintaining acceptable insertion forces and facilitating the range of desired surgical manipulations, e.g., angular instrument movements and specimen removal.

Accordingly, the present disclosure obviates the disadvantages of the prior art by providing a seal unit or assembly for a cannula assembly, which is capable of forming and maintaining a tight seal about instruments of varying diameters inserted through the cannula and which incorporates structure to enhance and facilitate passage of
30 the instrument through the seal unit.

SUMMARY

In accordance with an embodiment of the present invention there is provided a surgical access assembly for permitting access to body tissue, which comprises: an access

member dimensioned for introduction into body tissue, the access member defining a longitudinal axis and having a longitudinal passage to permit introduction of a surgical instrument; and a seal comprising a fabric material and being disposed relative to the access member, the seal having inner portions defining an aperture extending therethrough adapted to expand from an initial open condition to an expanded open condition upon passage of the surgical instrument in substantial sealed relation
10 therewith.

Yet another embodiment of the present invention provided a surgical seal assembly, which comprises: a housing defining a longitudinal axis and having a throughbore; and a seal member mounted within the housing, the seal member including an elastomeric material and a fabric material, the elastomeric material having inner portions arranged to define a passage in general longitudinal alignment with the throughbore of the housing to permit passage of an object, the inner portions of the
20 elastomeric material being adapted to resiliently contact the object in a substantially fluid tight manner.

A still further embodiment of the present invention provides a surgical seal assembly, which comprises: a housing defining a longitudinal axis and having a throughbore; and a seal member mounted within the housing, the seal member including an elastomeric material and a fabric material, the seal having inner portions defining an aperture adapted to expand from an initial open condition of the aperture to an expanded open condition of the aperture
30 upon passage of the object and to form a substantial sealed relation with the object.

The present disclosure provides a seal assembly for reception of an elongated surgical instrument, which in preferred embodiments

comprises a body having at least one opening configured and dimensioned to permit entry of an elongated surgical instrument and defining a central longitudinal axis; a seal member formed of a resilient material and defining an aperture therein, the aperture being configured and dimensioned such that insertion of the surgical instrument into the aperture causes the resilient material defining the aperture to resiliently contact the outer surface of the surgical instrument in a substantially fluid tight manner; and a fabric layer juxtaposed relative to the resilient material.

The seal assembly may further include a coating applied to the seal member to reduce friction between the seal member and surgical instrumentation inserted therein. The coating is preferably a hydrocyclosiloxane membrane prepared by plasma polymerization process.

In one aspect of the presently disclosed seal assembly a ring member is secured to the seal member and includes a dampening element disposed between a surface of the ring member and a surface of the body.

BRIEF DESCRIPTION OF THE DRAWINGS

Various embodiments are described herein below with reference to the drawings wherein:

FIG. 1 is a perspective view of one embodiment of a seal assembly constructed in accordance with the present disclosure;

FIG. 2 is a perspective view with parts separated showing the various structural components of the seal assembly embodiment of FIG. 1;

FIG. 3 is a perspective view of a fabric portion for incorporation into the seal element of the embodiment of FIG. 1;

FIG. 4 is a cross-sectional view taken along section line 4-4 of FIG. 3;

FIG. 5 is a perspective view of a fully formed seal member for the seal assembly of FIG. 1;

5 FIG. 6 is a cross-sectional view taken along section line 6-6 of FIG. 5;

FIG. 6A is an alternative embodiment of the seal element of FIG. 6;

10 FIG. 7 is a cross-sectional view of the seal assembly of FIG. 1;

FIG. 8 is a perspective view of a trocar assembly having the seal assembly of FIG. 1 removably installed thereon;

FIG. 9 is a partial cross-sectional view showing the seal body housing taken along section line 9-9 of FIG. 8;

15 FIG. 10 is an alternative embodiment of the seal assembly of the present disclosure;

FIG. 11 is a cross-sectional view of a further embodiment of the seal assembly constructed in accordance with the present disclosure;

20 FIG. 12 is a perspective view of the seal assembly of FIG. 11;

FIG. 13 is a perspective view with parts separated of the seal assembly embodiment of FIG. 11;

25 FIG. 14 is a cross-sectional view of a further embodiment of the seal assembly constructed in accordance with the present disclosure; and

FIG. 15 is a perspective view of the seal member of the seal assembly of FIG. 14.

DETAILED DESCRIPTION OF PREFERRED EMBODIMENTS

30 Referring now in detail to the drawing figures in which like reference numerals identify similar or identical elements, a first embodiment of the seal assembly of the present

disclosure is illustrated in FIGs. 1-9, and is designated generally as seal assembly 100.

The presently disclosed seal assembly embodiments contemplate the introduction of various types of surgical instruments adapted for insertion through an elongated trocar assembly. Examples of such instruments include clip appliers, graspers, dissectors, retractors, staplers, laser fibers, photographic devices, endoscopes and laparoscopes, tubes, and the like. Such instruments are collectively referred to herein as "instruments".

Referring to FIG. 2, seal assembly 100 includes a seal member 118 disposed within the seal assembly body or housing components 114 and 116 which snap fit together by way of flexible tab portions 114a being deflected upon insertion into receiving openings (not shown) formed in housing component 116. Seal member 118 has a circular array of holes formed therethrough around the periphery of an inner section 118b.

A two part ring assembly which includes ring members 120 and 122 are snap fitted together on either side of seal member 118. Ring member 120 is disposed adjacent the distally facing surface of seal member 118 and ring member 122 is disposed on the proximally facing side of seal member 118. Ring 120 is provided with holes 120a and posts 120b which are alternately disposed around the ring and are aligned with holes 118a on seal member 118. Ring 122 is provided with posts 122a and holes 122b which mate with holes 120a and posts 120b of ring member 120, respectively by snap fitting together thereby surrounding inner section 118b. Although rings 120 and 122 are shown having alternating holes and posts, one of the rings could have all holes formed therein while the other ring could have all posts aligned with the holes of the other ring. Additionally, greater or fewer holes and posts may be utilized to secure the two rings together.

A seal clamp 124 is provided within the housing component 114 and 116 and serves to secure the outer periphery of seal member 118 within seal assembly 100 (as best shown in FIG. 7). Seal clamp 124 is provided with four projecting posts 124a which fit within openings (FIG. 7) formed on the proximal side of lower housing 116. Seal clamp 124 also serves to secure a proximal flange of a lower seal 126 which is provided at the distal end of lower housing member 116. Lower seal 126 assists in the securement of seal assembly 100 to cannula assembly 110.

Referring now to FIGs. 3-6, seal member 118 includes a fabric disc-shaped portion 128 which is preferably disposed on both the proximal and distal sides of inner section 118b of seal member 118. Alternatively, fabric section 128 may be disposed on just one of either the proximally facing surface or the distally facing surface of inner portion 118b, as desired. Fabric portion 128 may be of any suitable fabric, for example, a SPANDEX material containing 20% LYCRA available from Milliken.

In one method of forming the composite seal member 118 with fabric portion 128 a raw, i.e., uncured polyisoprene plug is first compressed into a flat state, e.g., a flat sheet of polyisoprene. A single layer of fabric is positioned on top of the flattened polyisoprene sheet and compressed into the uncured rubber by any suitable compression process such as, for example, calendering. If it is desired to have fabric on both sides of seal member 118, this process is repeated on the other side of the polyisoprene sheet. The fabric polyisoprene composite is die cut into circular slugs having an outer diameter and an inner diameter which forms a central aperture. The slugs are placed in a hot compression mold to cure the polyisoprene. This step also serves to extrude the outer portions of seal member 118 which extend outwardly from inner section 118b.

During the above-described process the bleed-through of the polyisoprene material into and/or through the fabric layers is regulated by the density of the fabric selected. A greater degree of bleed-through of polyisoprene provides greater resistance to fraying of the fabric upon repeated insertion of instruments through the seal. However, too much bleed-through of the polyisoprene through the fabric will increase friction forces upon instruments
10 being inserted through seal member 118.

Referring to FIG. 6A, an alternative embodiment of seal member 118 is shown as seal member 418. Seal member 418 is the same as seal member 118 in most aspects except that inner section 418b is formed to have fabric layer 428 enveloped between upper and lower polyisoprene layers 418c and 418d.

In order to reduce friction between instruments and the seal member, e.g., seal member 118 or seal member 418, as instruments are inserted through seal assembly 100,
20 a coating may be applied to the seal member. One coating which has been found particularly effective is a hydrocyclosiloxane membrane prepared by plasma polymerization process. Such a coating is available from Innerdyne, Inc. of Salt Lake City, Utah, U.S.A., and is disclosed in U.S. Patent No. 5,463,010 which issued to Hu et al on October 31, 1995.

Referring to FIGs. 7 and 8, seal assembly 100 is used in combination with a conventional trocar assembly which includes a cannula assembly 110 and a trocar obturator
30 112. Examples of trocar assemblies in which the present seal assembly may be utilized are disclosed in U.S. Patent No. 5,603,702 which issued on February 18, 1997 to Smith et al and U.S. Patent No. 5,807,338 issued on September 15, 1998 to Smith et al.

Seal assembly 100, either alone or in combination with a seal unit/seal assembly internal to cannula assembly 110, provides a substantial seal between a body cavity of a patient and the outside atmosphere both during and subsequent to
5 insertion of an instrument through the cannula. In this manner, insufflation gases are prevented from escaping through the trocar assembly to the outside environment. Seal assembly 100 is capable of accommodating instruments of varying diameter, e.g., from about 5 mm to about 12 mm, while providing a fluid
10 tight seal with the outer diameter of each instrument. The versatility of the presently disclosed seal assembly embodiments greatly facilitate endoscopic surgery, wherein a variety of instruments having different diameters are often needed during a single surgical procedure.

15 Seal assembly 100 is preferably detachably mountable to the proximal end of cannula assembly 110. Thus, the surgeon can remove the seal assembly 100 from the cannula assembly 110 at any time during the surgical procedure and, similarly, mount the seal assembly 100 to the cannula when
20 desired in order to provide a sealing engagement with an instrument to be inserted through the cannula. In addition, seal assembly 100 may be readily adapted for mounting to conventional cannulas of differing structures. The detachability of seal assembly 100 from cannula assembly 110
25 facilitates specimen removal through cannula assembly 110. Seal assembly 100 includes a housing which is formed by the snap fitting together of end cap 114 and lower housing member 116. Preferably the housing components of seal assembly 100 are formed of a polycarbonate material such as ABS available from
30 the General Electric Company.

FIG. 9 shows an instrument having a shaft 130 inserted through seal assembly 100 and a duck bill valve or "zero" seal valve 132 which prevents the escape of insufflation

gases in the absence of an instrument in the trocar assembly. As shown in FIG. 9, seal member 118 provides a seal about the periphery of shaft 130.

Referring to FIG. 10, an alternate embodiment of seal assembly 100 is designated generally as seal assembly 150. Seal assembly 150 is the same as seal assembly 100 except that an inner planar seal member 152 is disposed in the distal end of seal assembly 100 to provide additional sealing capability for instruments having larger diameters. Seal element 152 has an aperture 154 which has a diameter larger than the diameter of aperture 156 of seal member 118. A further feature illustrated in FIG. 10 is a dampening member such as pad 158 which is secured to the proximal surface of ring 122 to dampen the sound created by the impact of the proximal surface of ring 122 with the inner distal facing surface of housing component 114. Other dampening member configurations are also contemplated. For example, ring 122 may be over-molded with material such as polyisoprene so as to envelope part or all of the ring thereby forming a bumper between the ring and the housing component.

Referring to FIGS. 11-13, a further embodiment of a seal assembly generally designated as seal assembly 200 is shown throughout the several views. Seal member 218 is configured in an hourglass shape and preferably includes the fabric portion 228 formed as part of seal member 218 in a similar manner as described above. The friction reducing coating of a hydrocyclosiloxane membrane prepared by plasma polymerization process noted above may also be utilized to coat the surfaces of seal member 218.

Referring now to FIGS. 14 and 15, a further embodiment of the seal assembly generally designated as seal assembly 300 is shown. Seal member 318 is similar to seal member 118 except that inner portion 318b is formed in a conical shape with a wider opening directed towards a proximal end of

seal assembly 300 and a narrower opening directed towards distal
end of seal assembly 300. The friction reducing coating of a
hydrocyclosiloxane membrane prepared by plasma polymerization
process noted above may also be utilized to coat the surfaces of
5 seal member 318.

It will be understood that various modifications
may be made to the embodiments shown herein. Therefore, the
above description should not be construed as limiting, but
merely as exemplifications of preferred embodiments. Those
10 skilled in the art will envision other modifications within the
scope and spirit of the presently disclosed seal assemblies.

THE EMBODIMENTS OF THE INVENTION IN WHICH AN EXCLUSIVE PROPERTY OR PRIVILEGE IS CLAIMED ARE DEFINED AS FOLLOWS:

1. A surgical access assembly for permitting access to body tissue, which comprises:

an access member dimensioned for introduction into body tissue, the access member defining a longitudinal axis and having a longitudinal passage to permit introduction of a surgical instrument; and

a seal comprising a fabric material and being disposed relative to the access member, the seal having inner portions defining an aperture extending therethrough adapted to expand from an initial open condition to an expanded open condition upon passage of the surgical instrument in substantial sealed relation therewith.

2. The surgical access assembly according to claim 1 wherein the seal further includes an elastomeric material.

3. The surgical access assembly according to claim 2 wherein the seal is a septum seal.

4. The surgical access assembly according to claim 2 wherein the seal is elongated and extends relative to the longitudinal axis of the access member.

5. The surgical access assembly according to claim 4 wherein the seal defines a general hourglass configuration.

6. The surgical access assembly according to claim 4 wherein the seal defines a general conical configuration.

7. The surgical access assembly according to claim 2 wherein the elastomeric material is arranged to be an outer layer of the seal.

8. The surgical access assembly according to claim 2 wherein the seal includes a first ring supported on a leading surface of the seal and a second ring member supported on a trailing surface of the seal.

9. The surgical access assembly according to claim 8 wherein first and second ring members are adapted to be snap-fitted together.

10. The surgical access assembly according to any one of claims 1 to 9 wherein the access member includes a cannula.

11. The surgical access assembly according to claim 10 wherein the access member includes a housing operatively connectable to the cannula, the seal being mounted within the housing.

12. A surgical seal assembly, which comprises:
a housing defining a longitudinal axis and having a throughbore; and
a seal member mounted within the housing, the seal member including an elastomeric material and a fabric material, the elastomeric material having inner portions arranged to define a passage in general longitudinal alignment with the throughbore of the housing to permit passage of an object, the inner portions of the elastomeric material being adapted to resiliently contact the object in a substantially fluid tight manner.

13. The surgical seal assembly according to claim 12 wherein the fabric material comprises a layer of fabric material.

14. The surgical seal assembly according to claim 13 wherein a layer of fabric material is disposed on each of opposed surfaces of the elastomeric material.

15. The surgical seal assembly according to claim 12 wherein the elastomeric material comprises at least two layers of elastomeric material and the fabric material comprises at least one layer of fabric material at least partially disposed between the at least two layers of elastomeric material.

16. The surgical seal assembly according to any one of claims 12 to 15 wherein the seal member defines a general hour glass configuration.

17. The surgical seal assembly according to any one of claims 12 to 15 wherein the seal member defines a general conical configuration.

18. The surgical seal assembly according to any one of claims 12 to 15 wherein the seal member includes a peripheral portion adapted to deform in response to movement of the object in a direction transverse to the longitudinal axis.

19. The surgical seal assembly according to claim 12 wherein the fabric material of the seal is at least partially embedded in the elastomeric material of the seal.

20. The surgical seal assembly according to any one of claims 12 to 19 wherein the inner portions of the seal define an aperture adapted to expand from an initial open condition to an expanded open condition upon passage of the object and in substantial sealed relation therewith.

21. A surgical seal assembly, which comprises:
a housing defining a longitudinal axis and having a throughbore; and
a seal member mounted within the housing, the seal member including an elastomeric material and a fabric material, the seal having inner portions defining an aperture adapted to expand from an initial open condition of the aperture to an expanded open condition of the aperture upon passage of the object and to form a substantial sealed relation with the object.

1/10

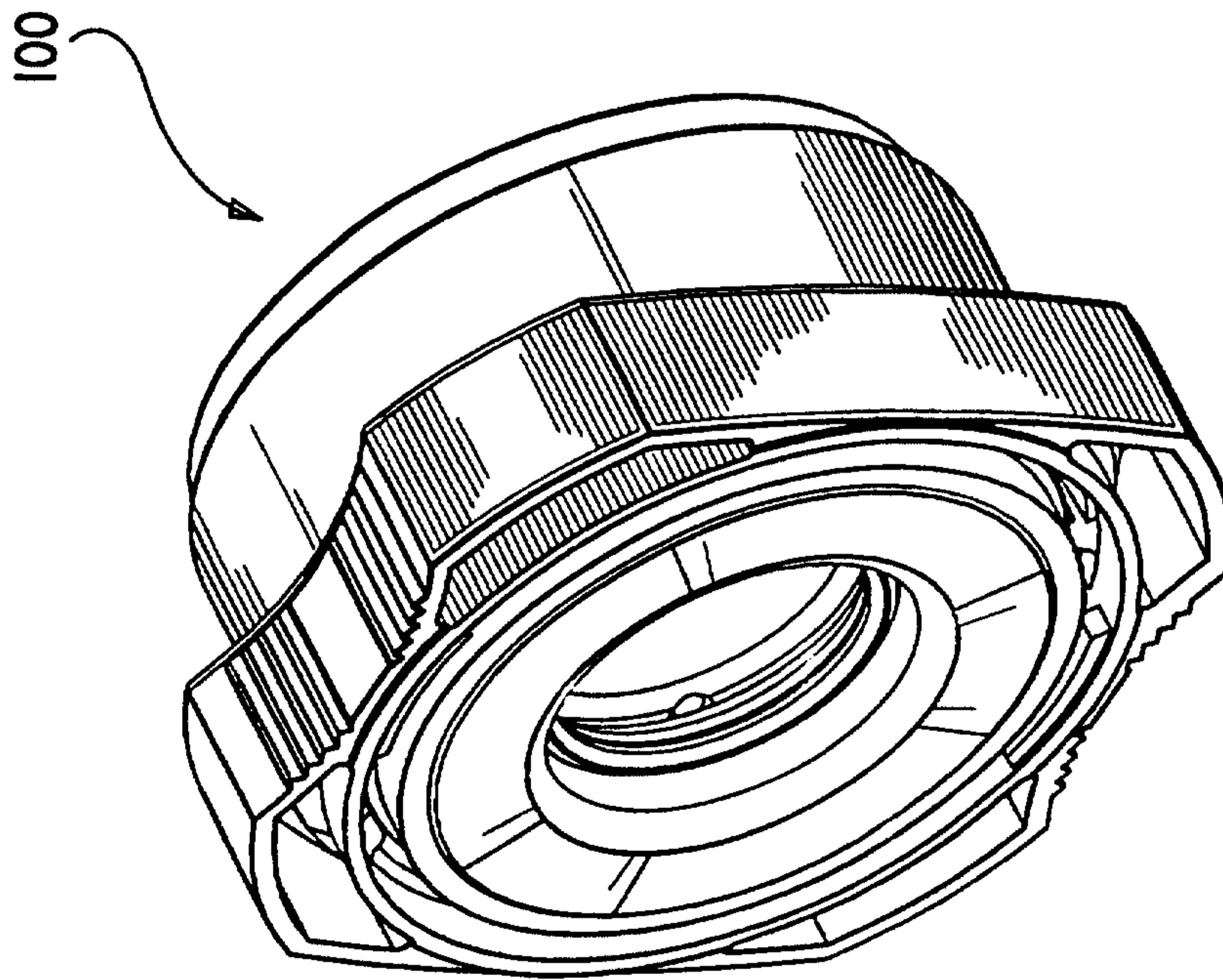

FIG. 1

2/10

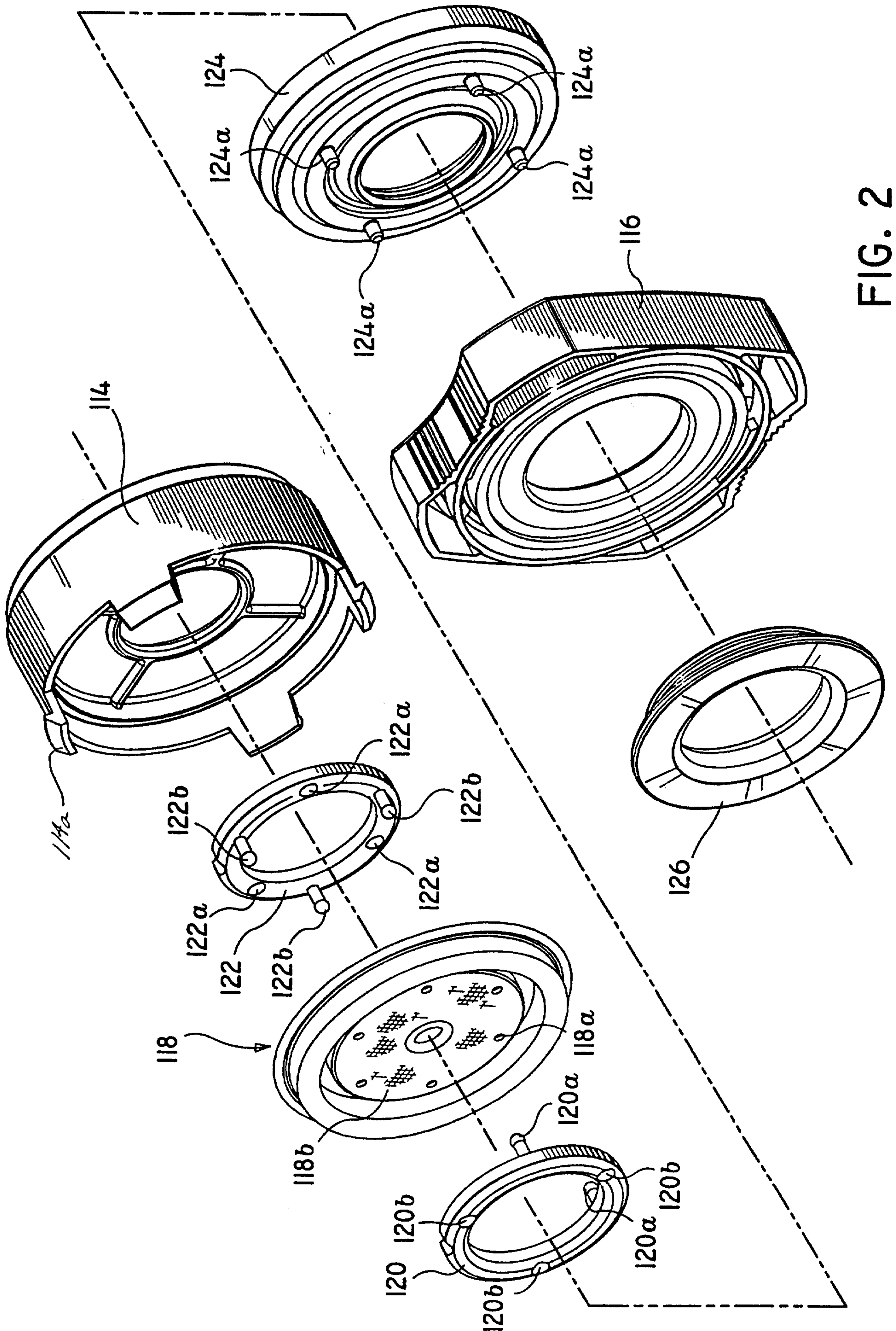

FIG. 2

3/10

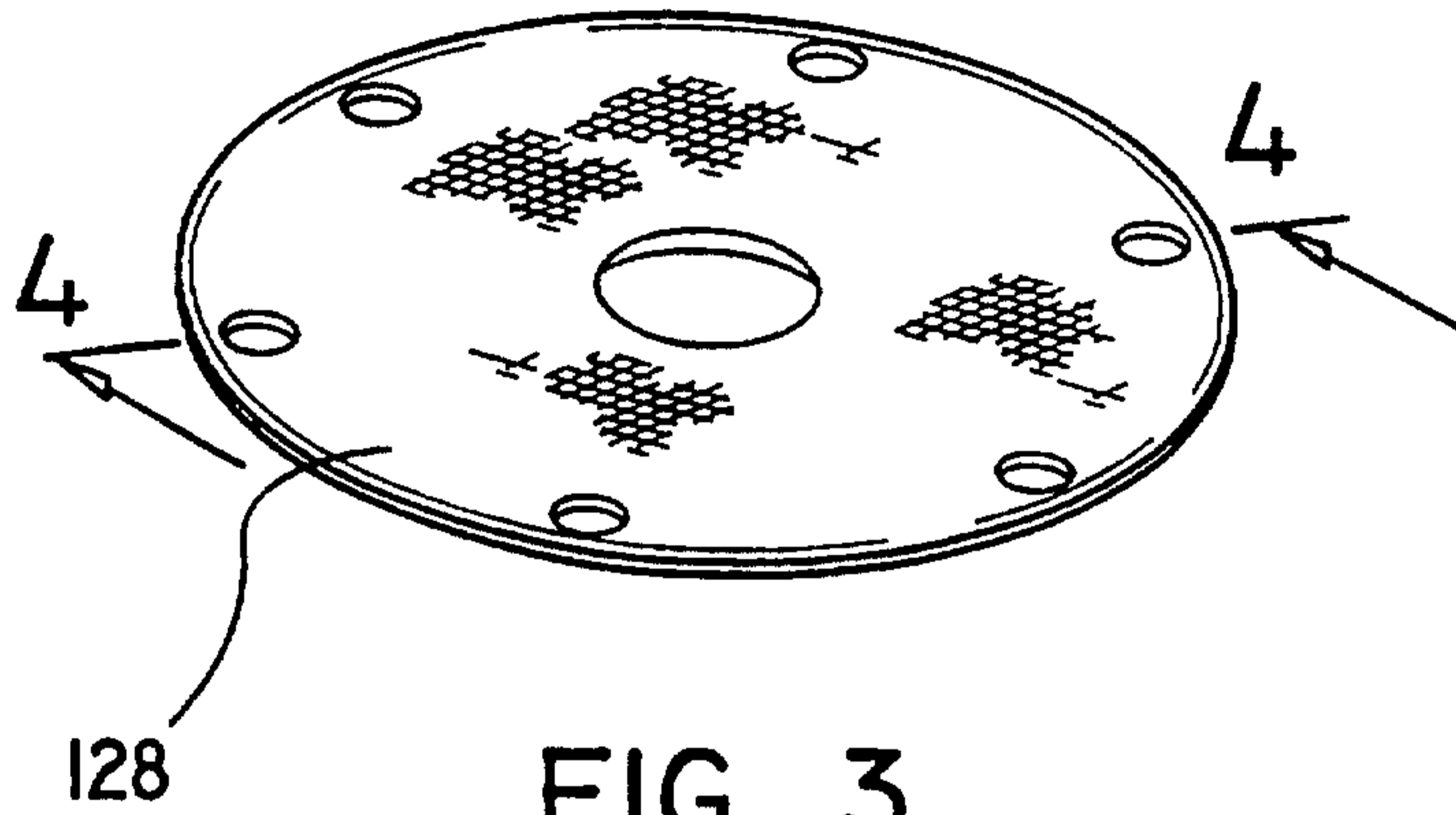

FIG. 3



FIG. 4

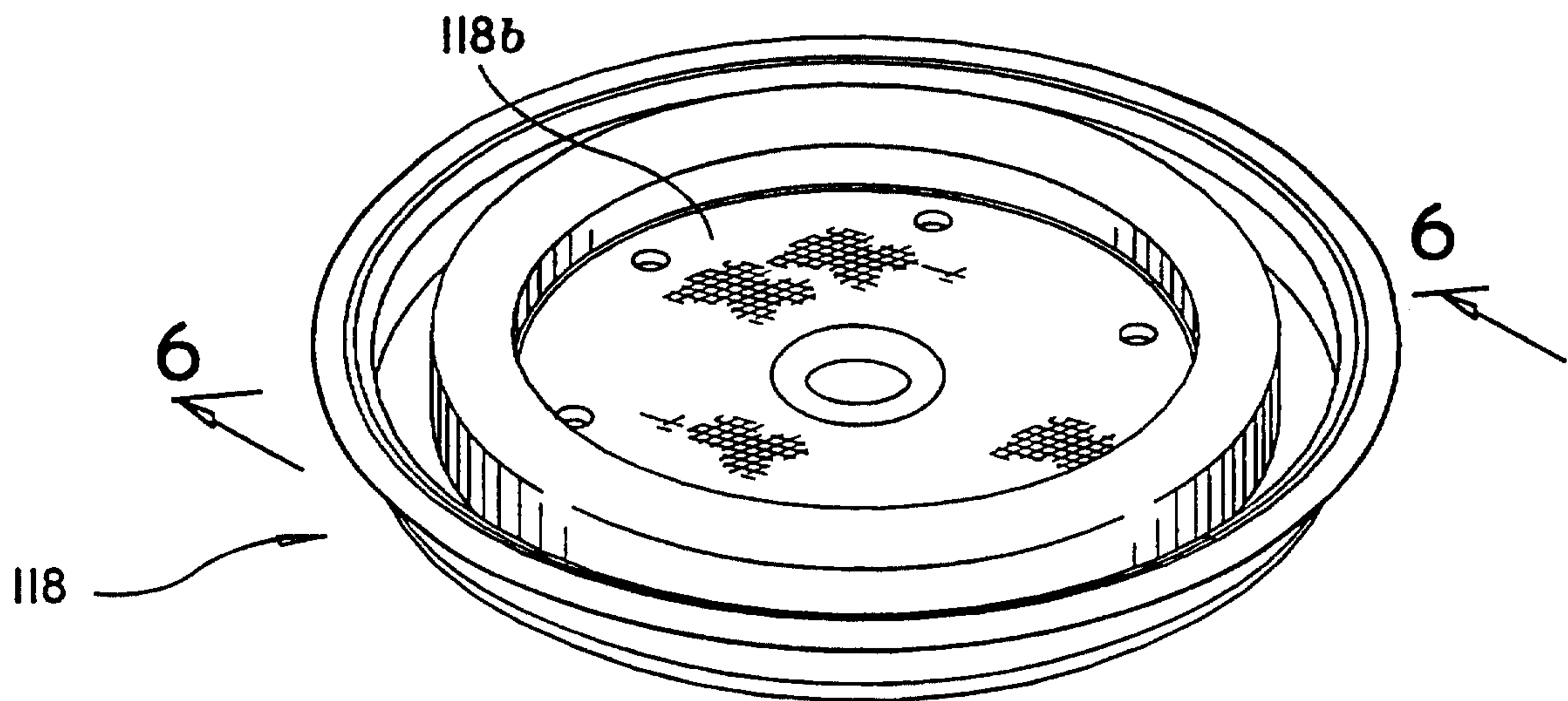

FIG. 5

4/10

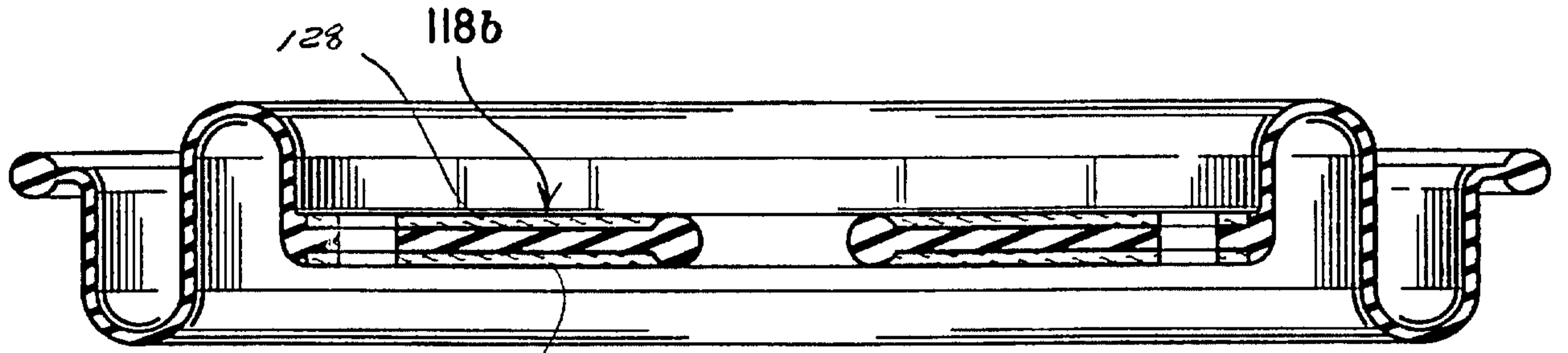

FIG. 6

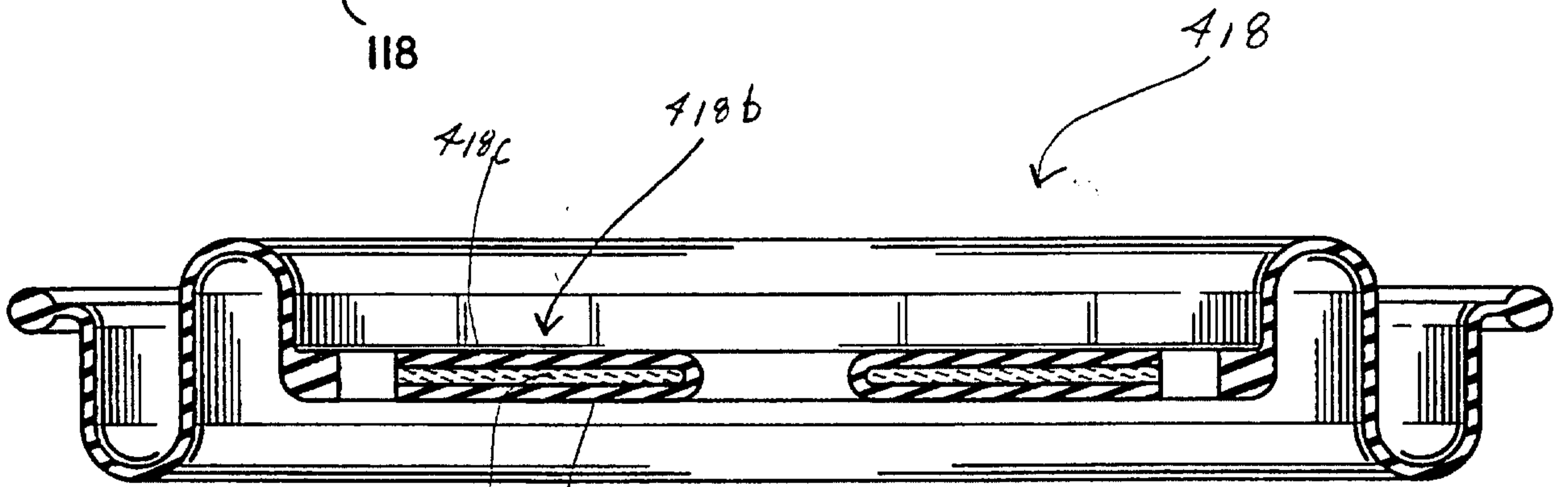

FIG. 6A

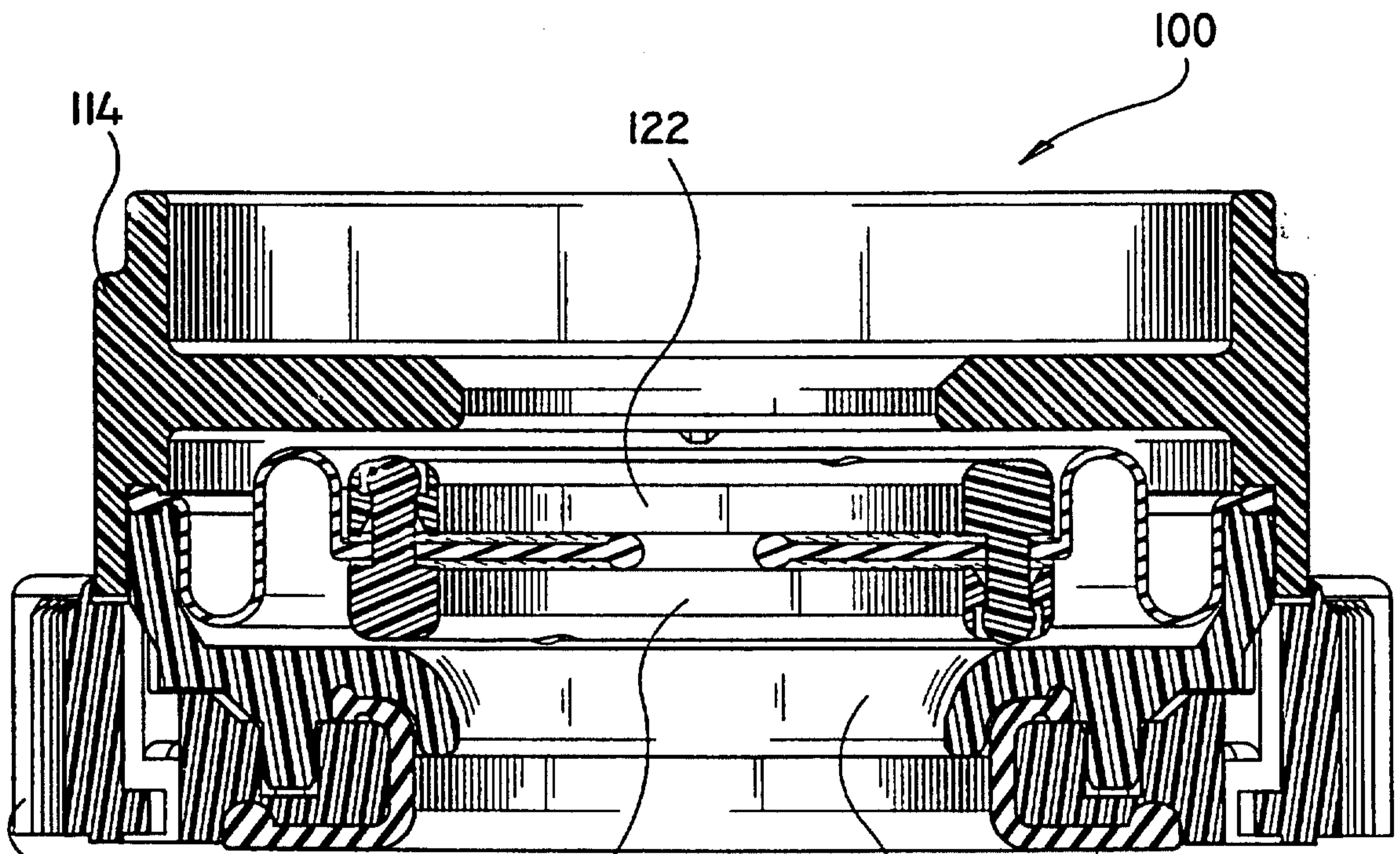

FIG. 7

5/10

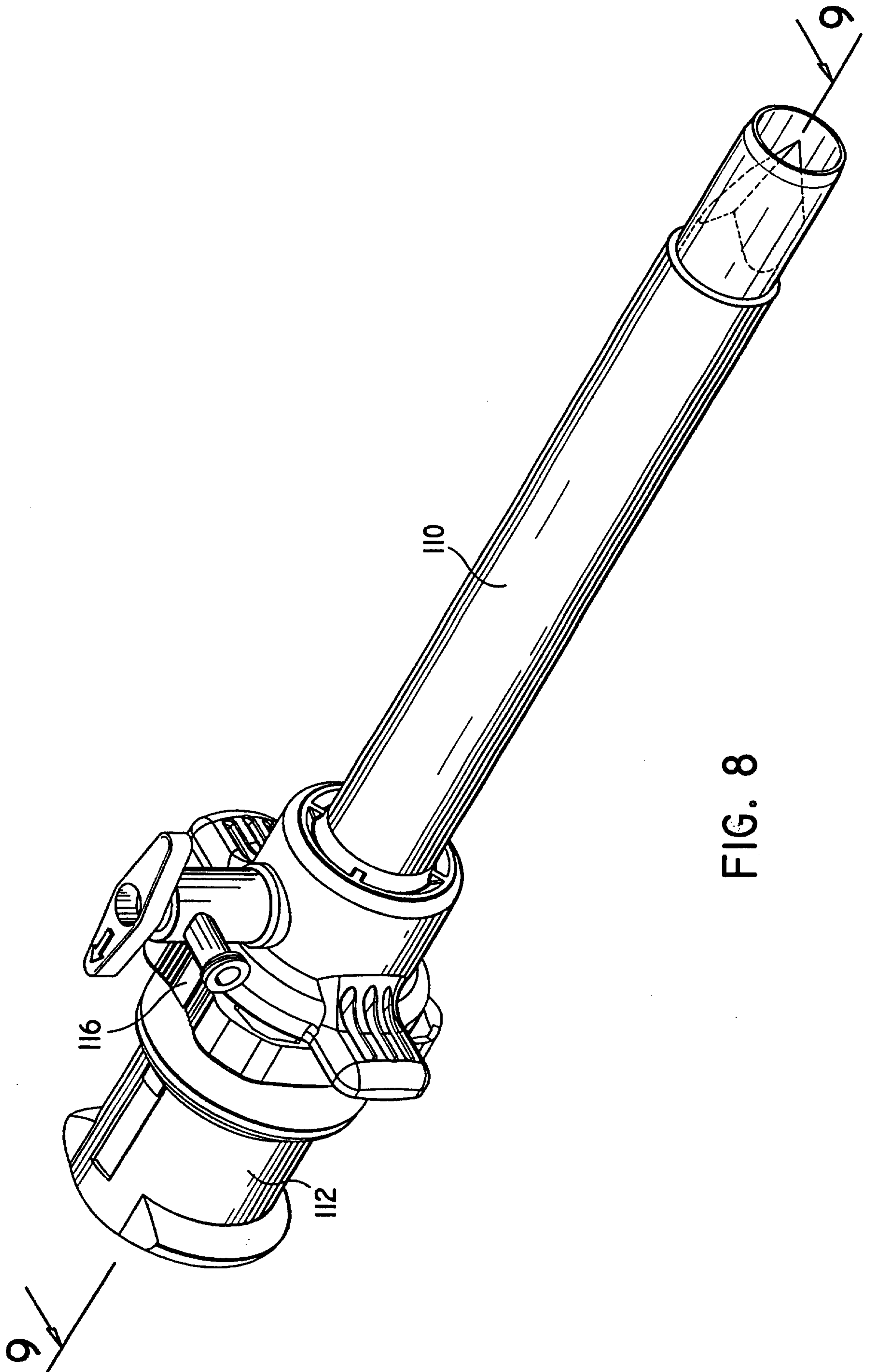

FIG. 8

6/10

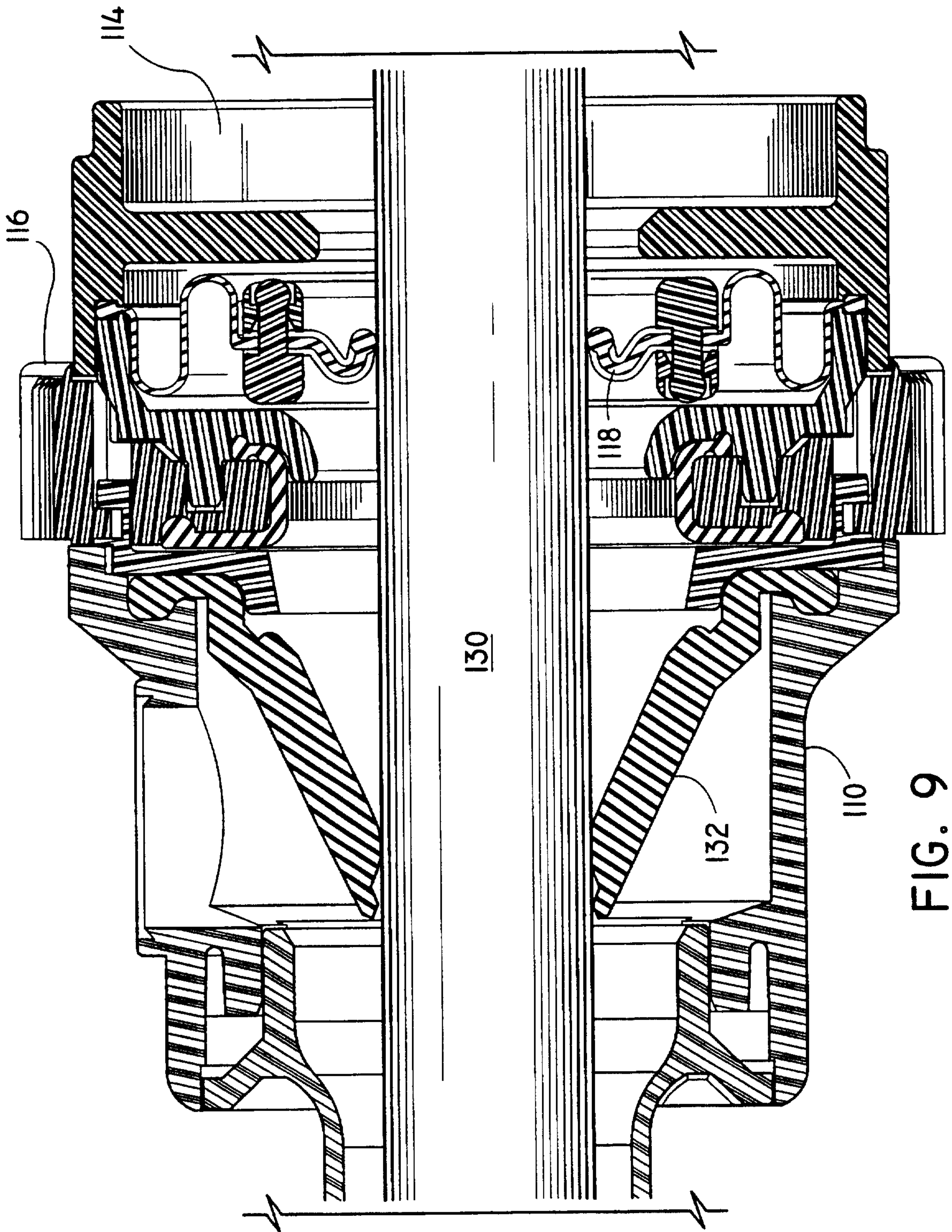

FIG. 9

7/10

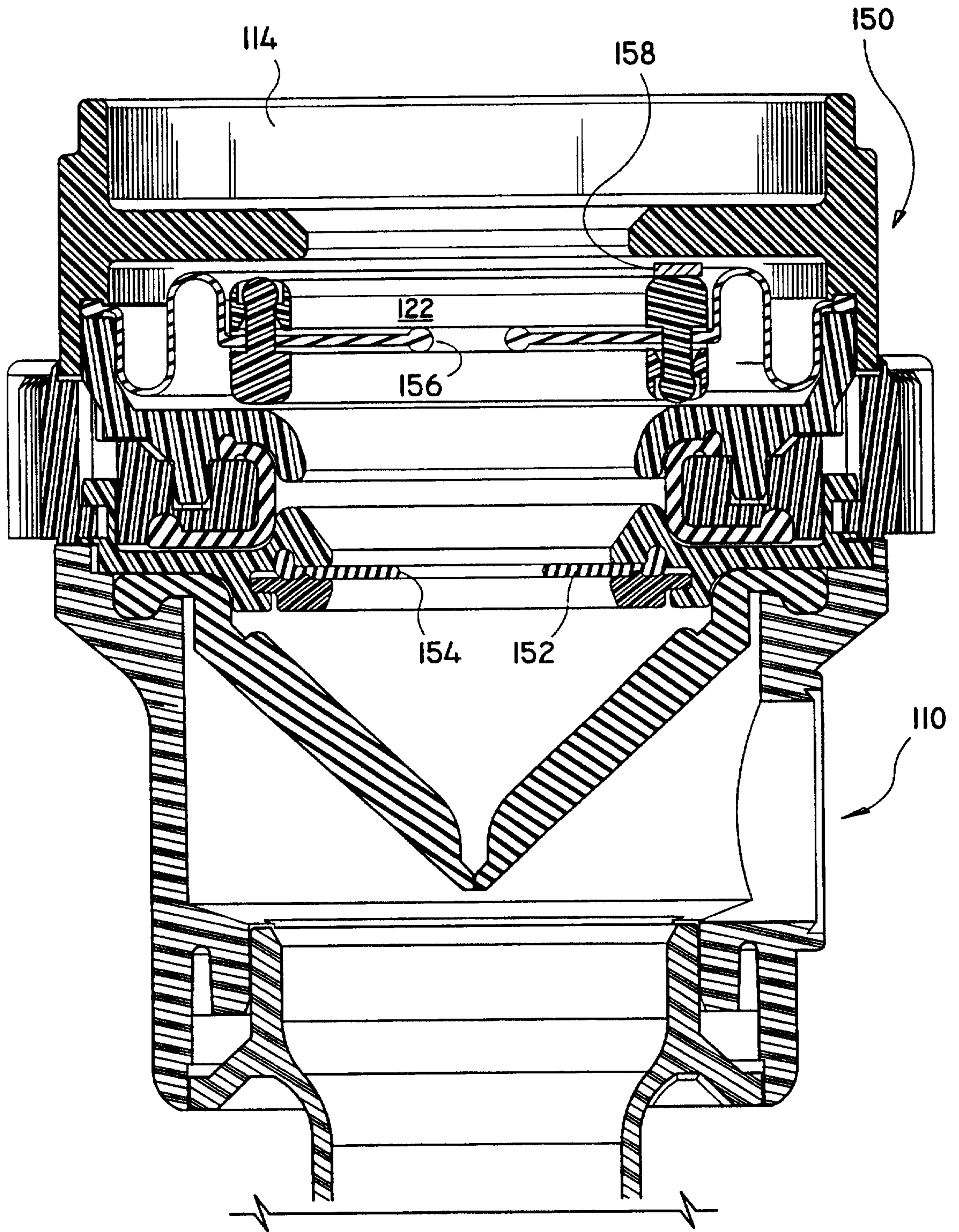

FIG. 10

8/10

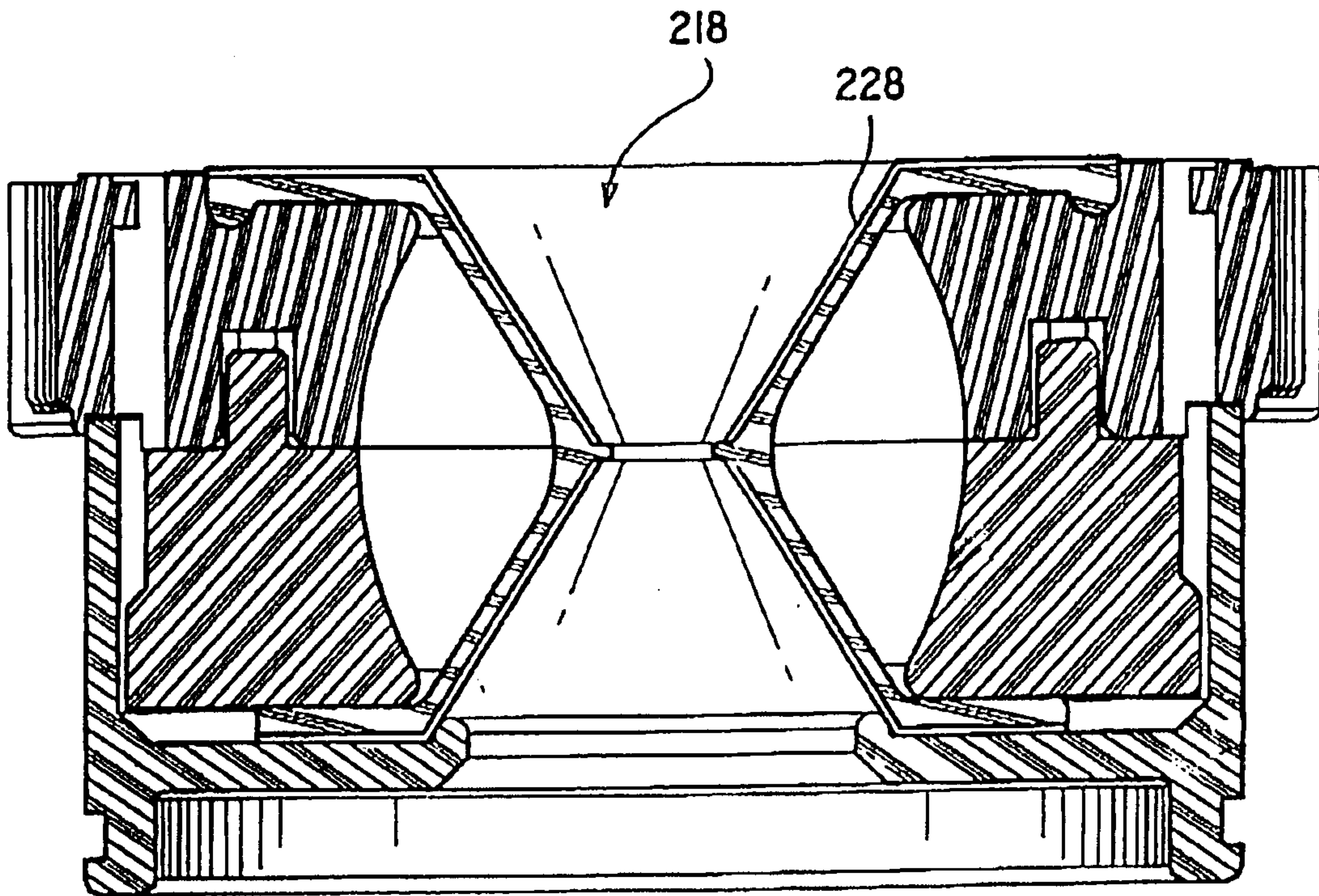

FIG. 11

200

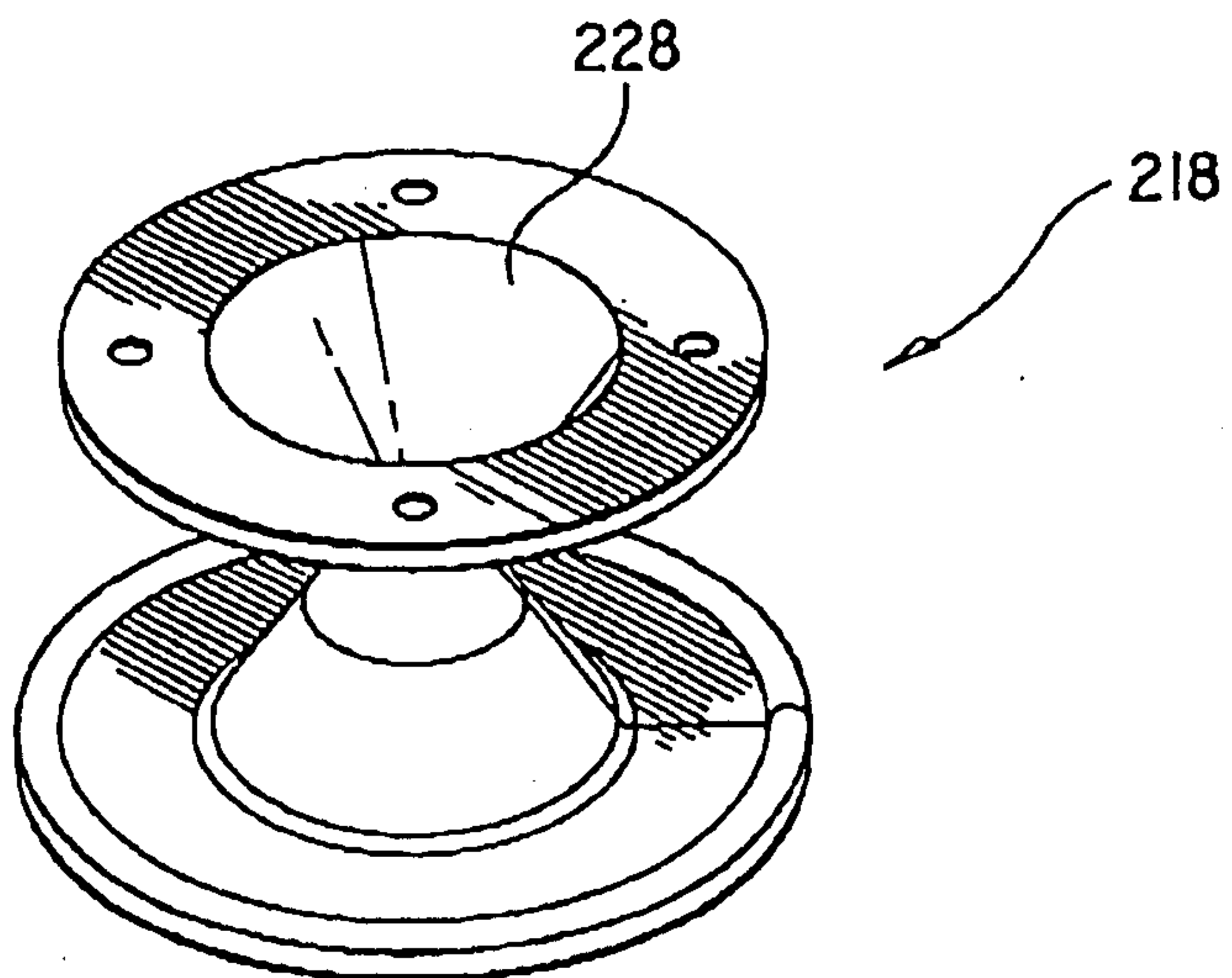

FIG. 12

9/10

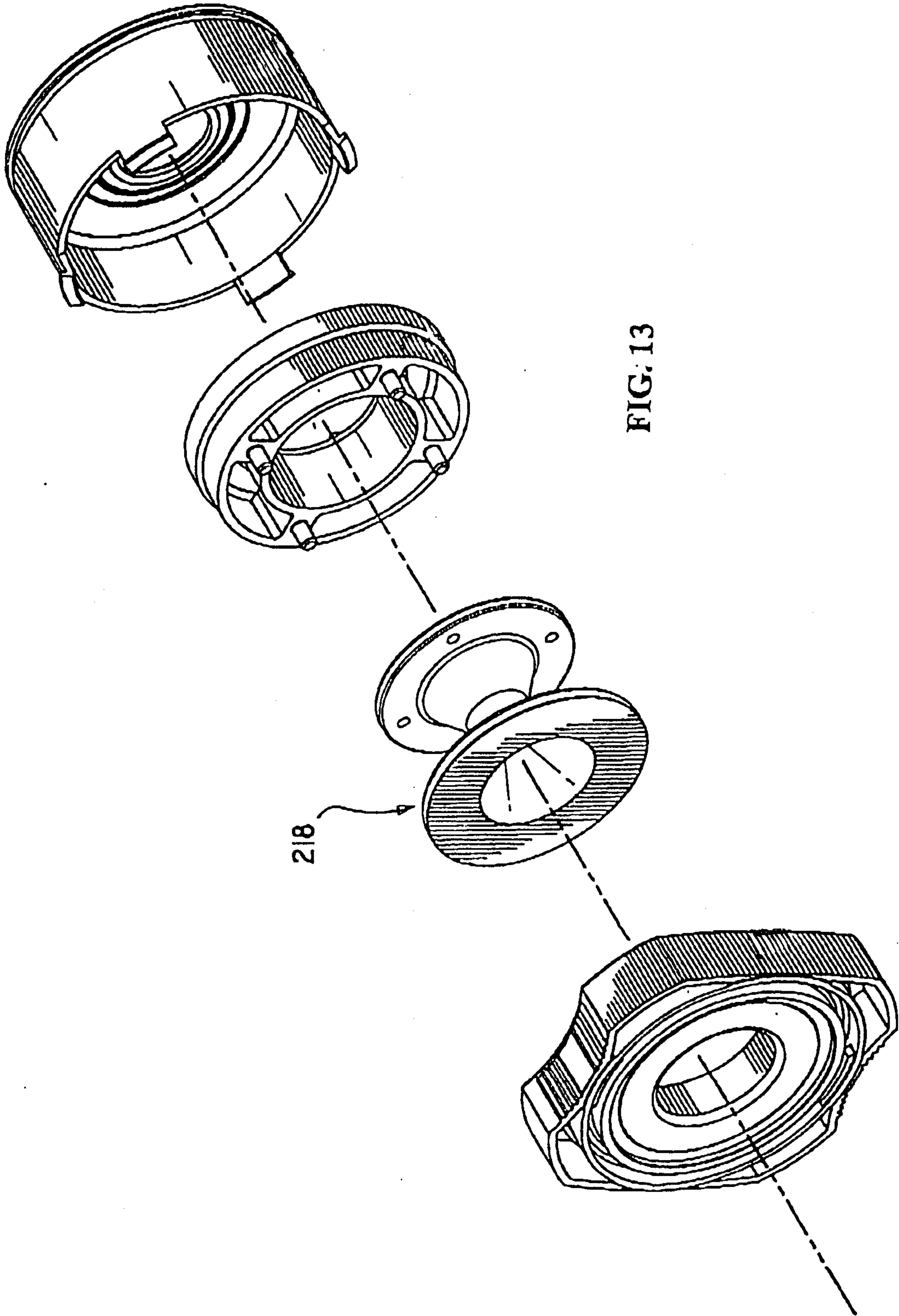
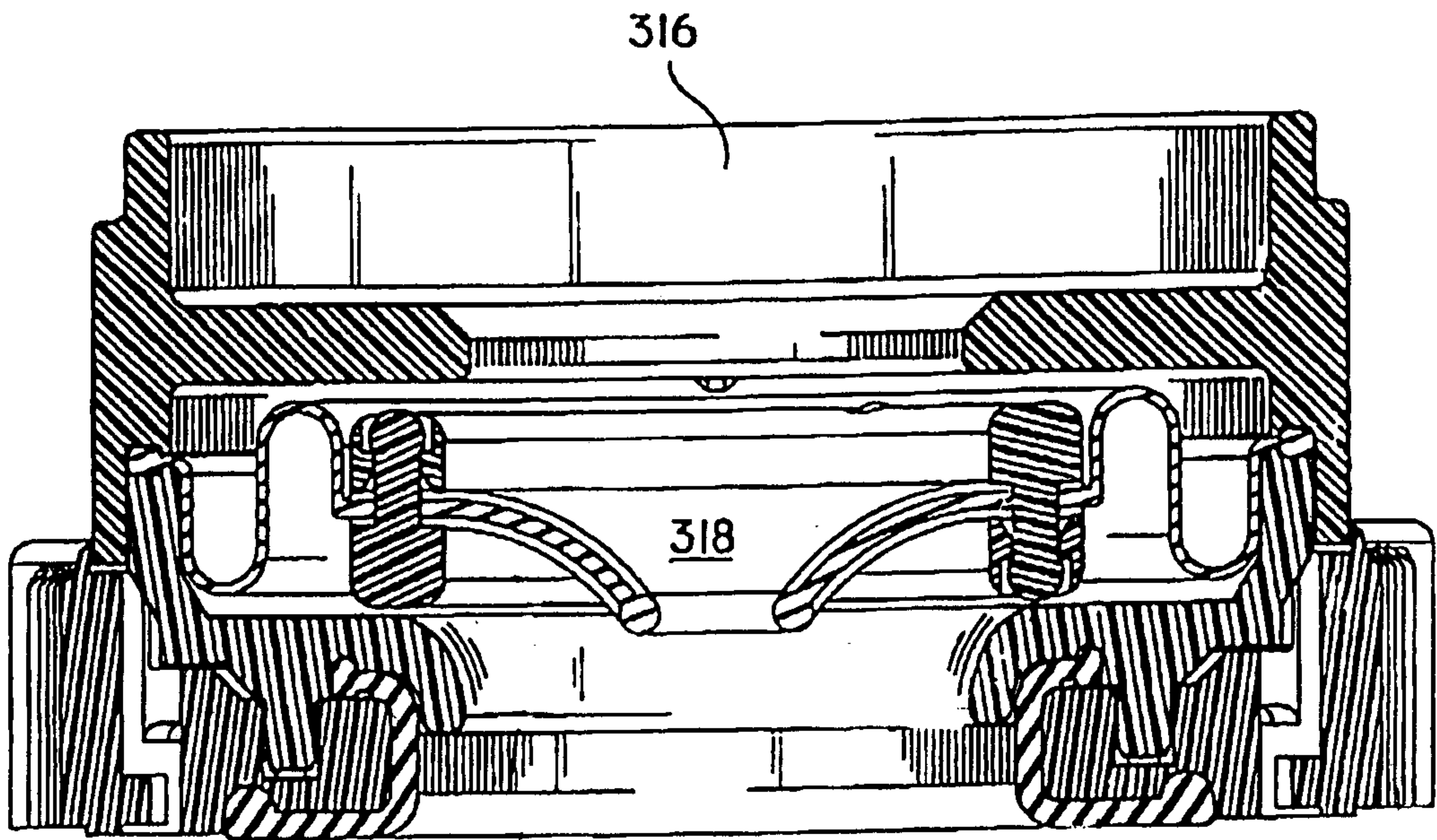

FIG. 13

10/10



300

FIG. 14

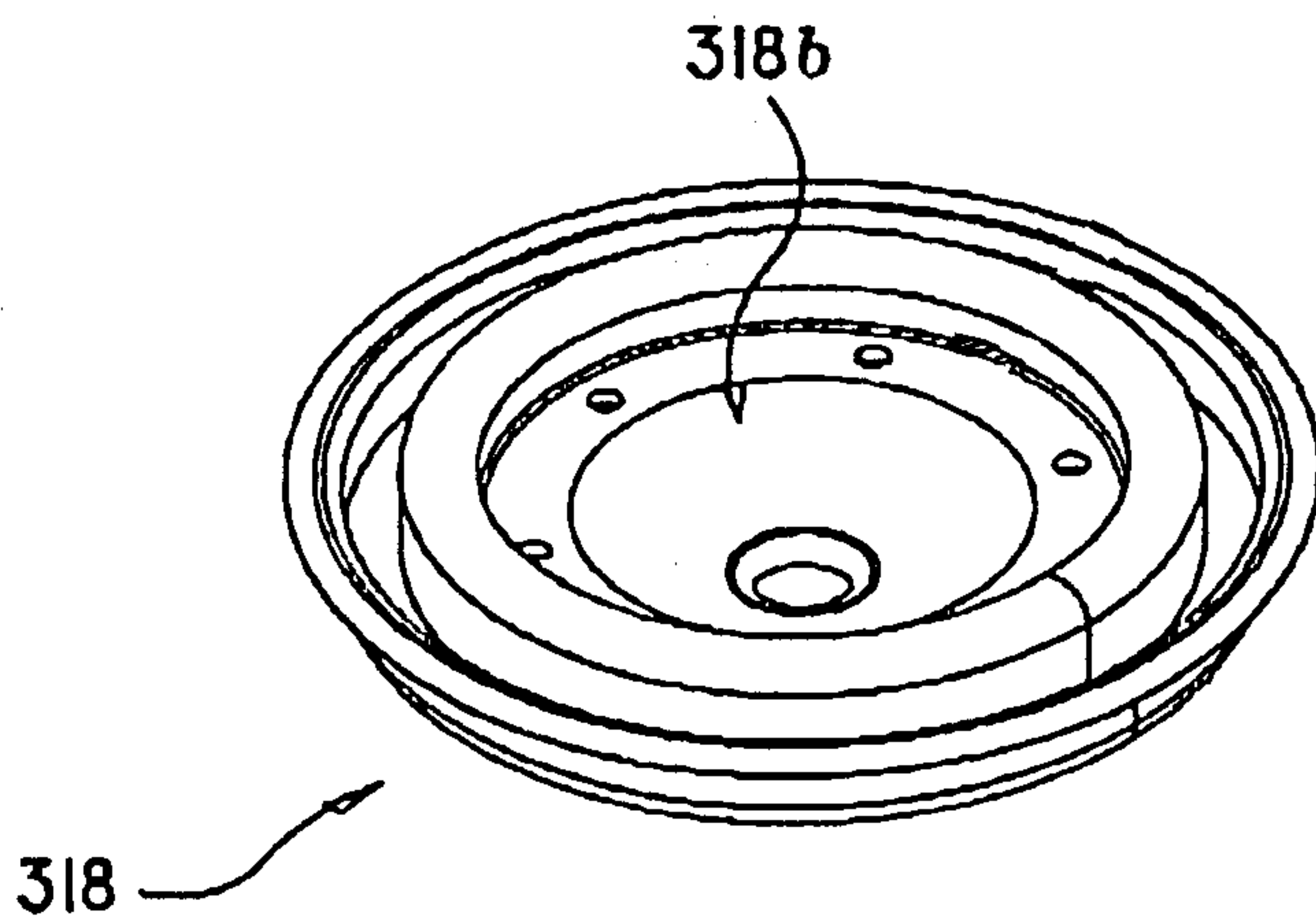

FIG. 15

