



---

(12) UK Patent (19) GB (11) 2 208 774 (13) B

---

(54) Title of Invention

Base station for wireless digital telephone system

(51) INT CL<sup>5</sup>; H04Q 11/04

---

(21) Application No  
8806221.1

(22) Date of filing  
16.03.1988

(30) Priority Data

(31) 071279

(32) 14.08.1987

(33) US

(43) Application published  
12.04.1989

(45) Patent published  
31.07.1991

(72) Inventor(s)  
Graham M Avis  
Terrence Stephen Collins  
Martin Keith Schroeder  
Brian Gregory Kiernan  
Jonathan Willis Mechling  
Thomas E Fletcher  
Wendeline R Avis  
Gregory T Saffee  
Karle J Johnson

(73) Proprietor(s)  
International Mobile Machines  
Corporation

(Incorporated in USA -  
Pennsylvania)

100 North 20th Street  
Philadelphia  
Pennsylvania 19103  
United States of America

---

(52) Domestic classification  
(Edition K)  
H4K KYR K1U1 K1U7

(56) Documents cited  
None

(58) Field of search

As for published application  
2208774 A viz:  
UK CL(Edition J) H4K KTM  
KTS KYR  
INT CL<sup>4</sup> H04Q  
updated as appropriate

(74) Agent and/or  
Address for Service  
Carpmaels and Ransford  
43 Bloomsbury Square  
London  
WC1A 2RA  
United Kingdom

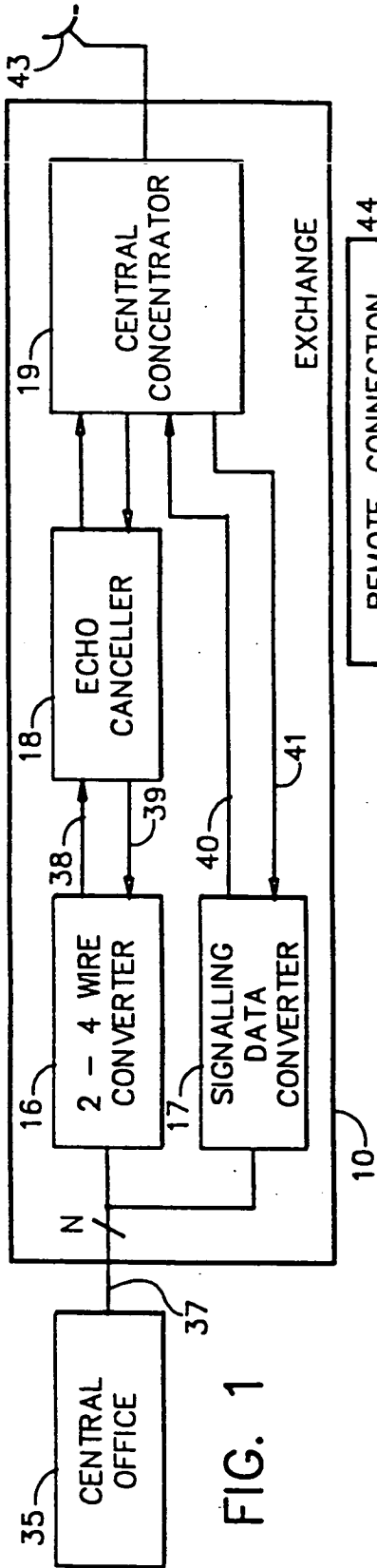

FIG. 1

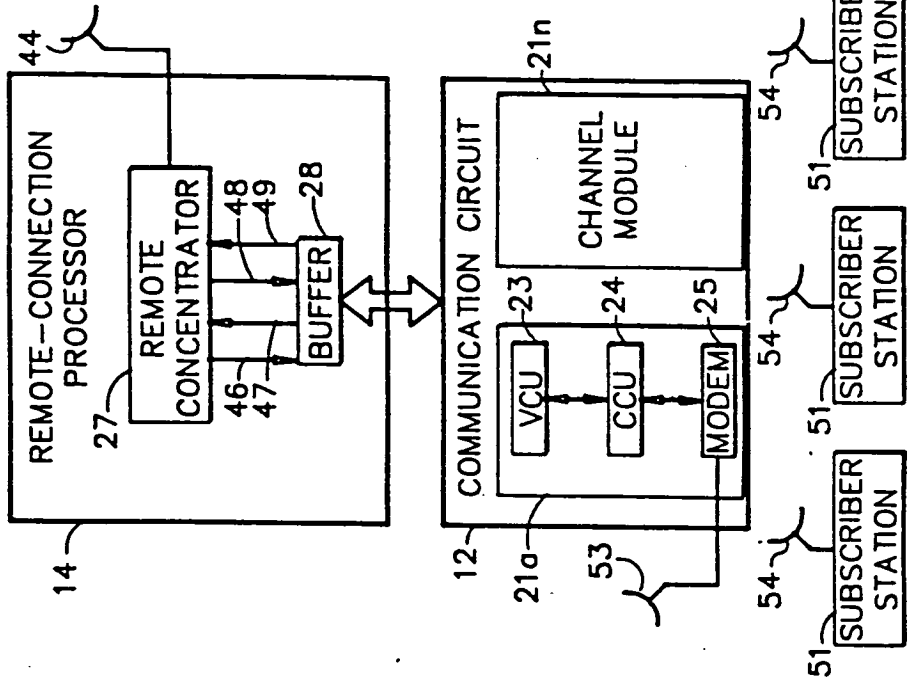

FIG. 2

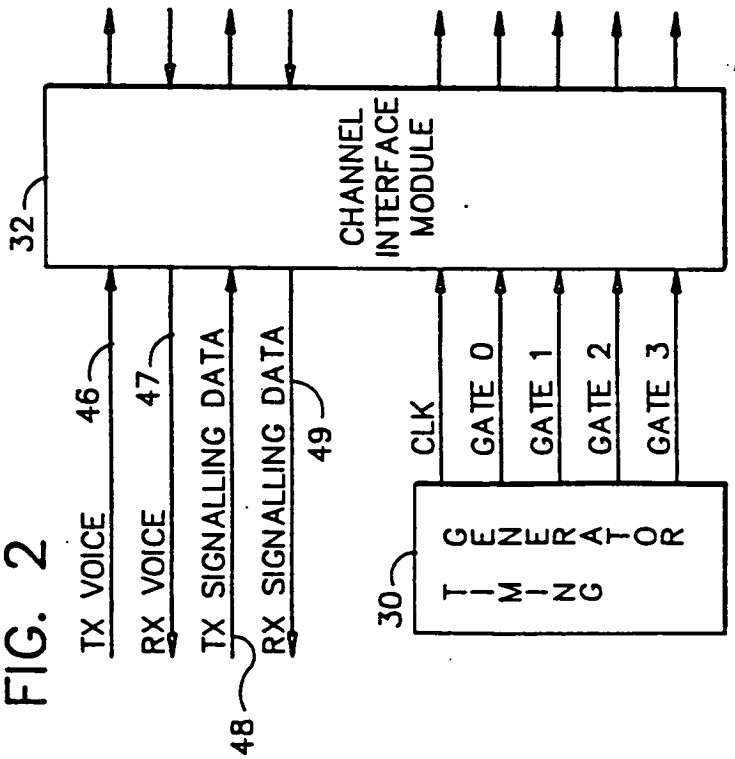
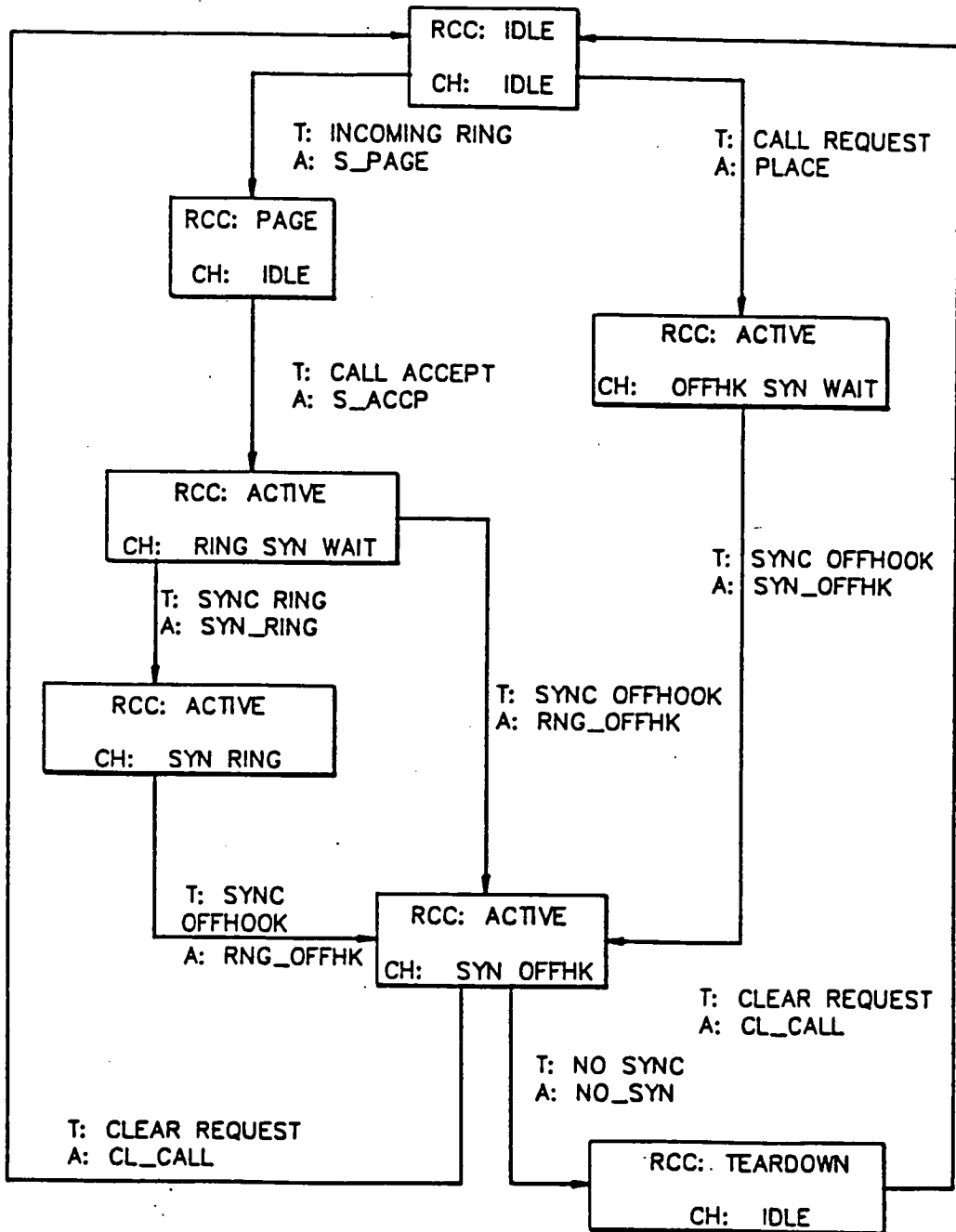

FIG.3





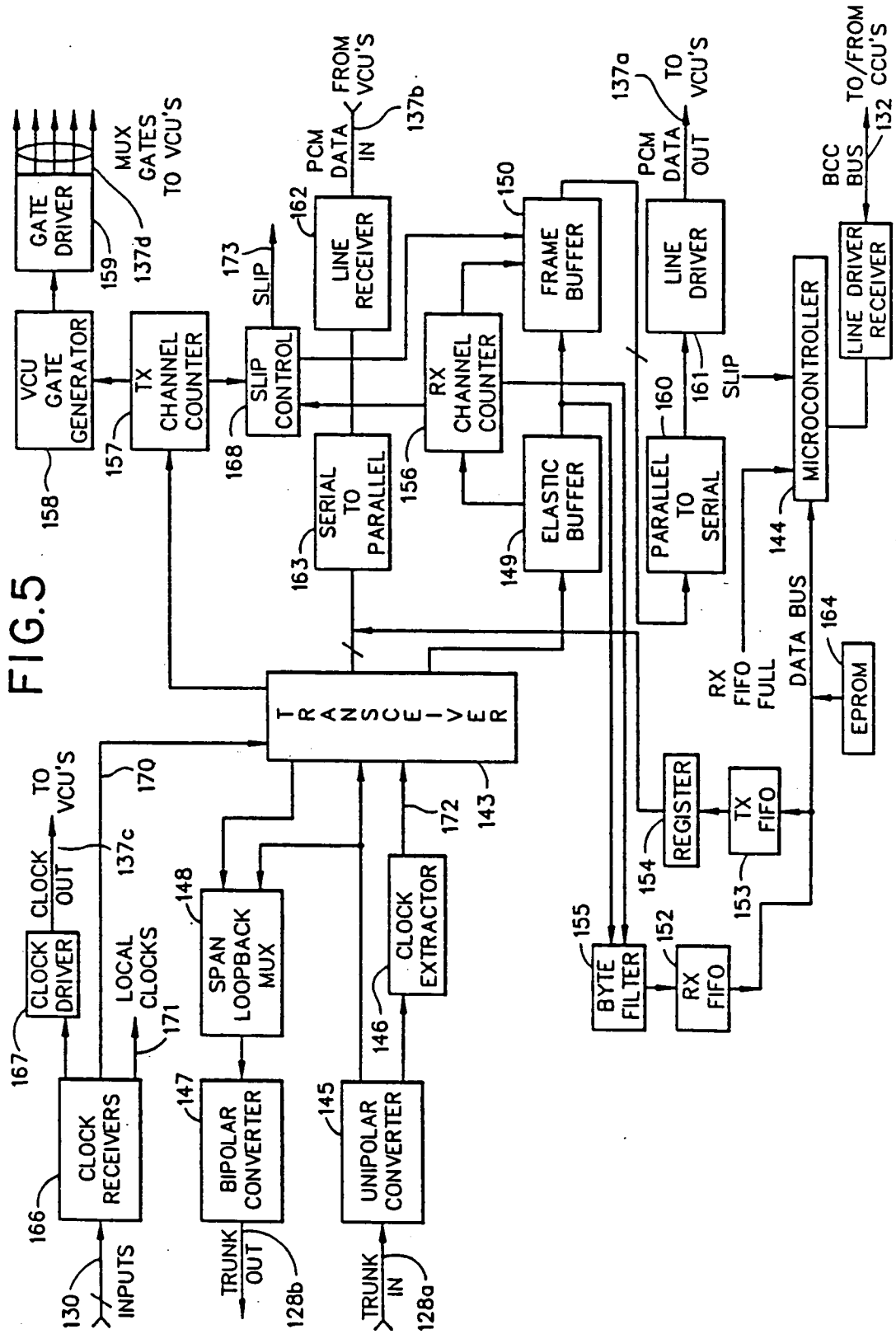
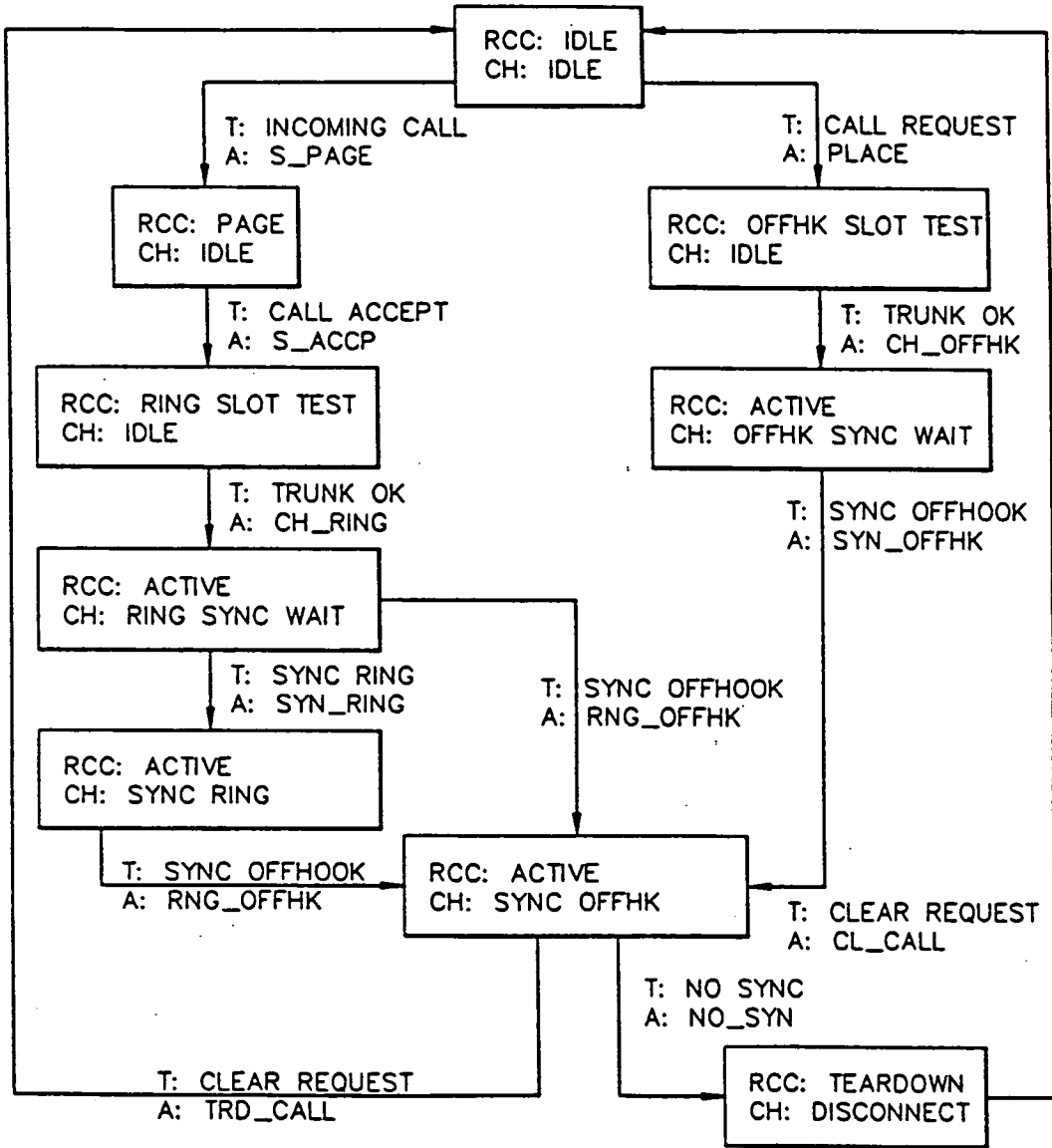

FIG.6



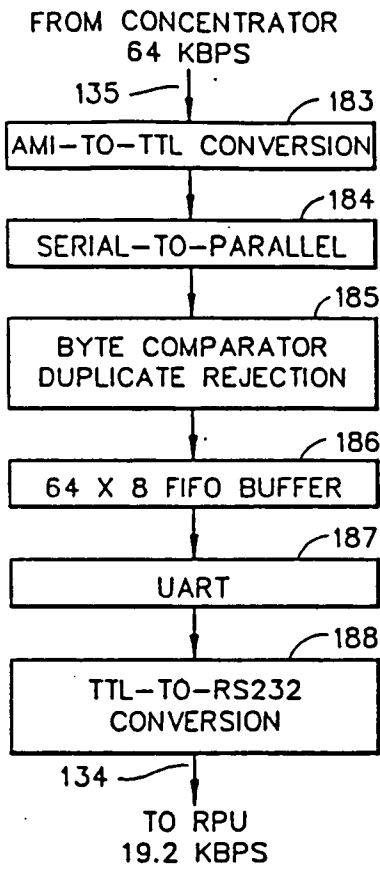

FIG. 7A

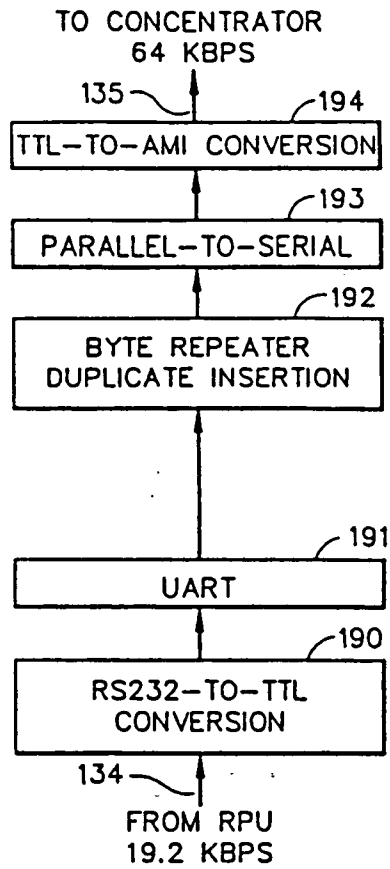

FIG. 7B

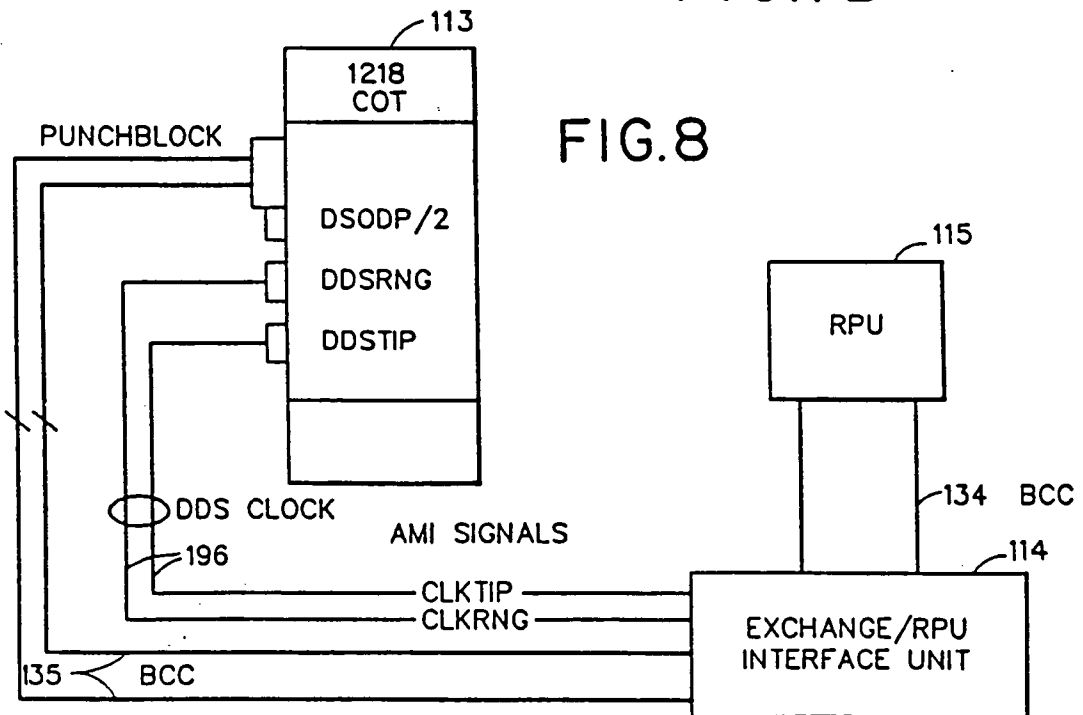

FIG. 8

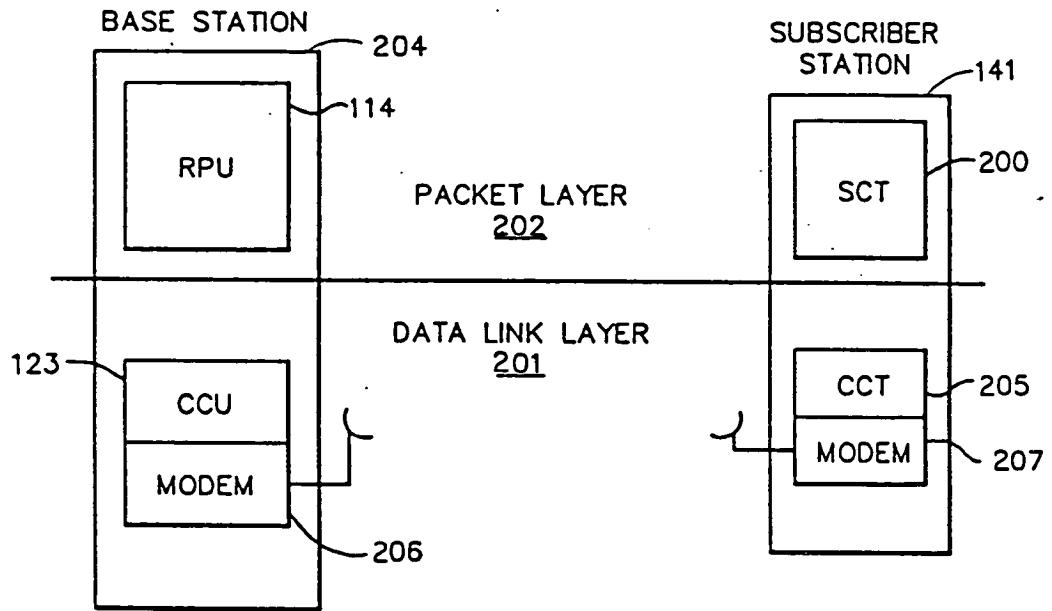

FIG.9

2208774

BASE STATION FOR WIRELESS DIGITAL TELEPHONE SYSTEM

BACKGROUND OF THE INVENTION

The present invention generally pertains to communications systems and is particularly directed to an improved base station for use in a subscriber communication network, such as a wireless digital telephone system.

The base station of the present invention communicates signals between subscriber stations and an external communication network having a plurality of ports. Such base station includes a communication circuit for enabling simultaneous communications between a plurality of the ports and a plurality of subscriber stations over a given communication channel having multiple sequentially repetitive time slots, with predetermined time slots being assigned respectively to predetermined subscriber stations; a remote-connection processor (RPU) for directing communications between the time slot assigned to a given subscriber station and a given port; and an exchange for connecting the communication circuit to the ports. The exchange includes a switch which responds to a control signal from the RPU by physically connecting a selected port to a selected communication channel time slot assigned to a given subscriber station. The communication circuit includes a plurality of channel control units (CCUs) for coupling the assigned communication channel time slot to the given subscriber station in response to a command signal communicated by the RPU to CCUs over a base-station control channel (BCC) in response to status messages provided over the BCC to the RPU to indicate the usage status of the communication channel time slots and the subscriber stations. The assigned communication channel time slot is coupled to the given subscriber station by an assigned time slot in an assigned radio frequency (RF) channel. The BCC is provided over lines separately connected directly from the RPU to each of the CCUs. Control commands and status messages are communicated between the CCUs and the subscriber stations over a

radio control channel (RCC) assigned to a predetermined time slot of a predetermined RF channel.

#### SUMMARY OF THE INVENTION

5 The present invention provides an improved base station of the type generally described above. Preferably, the exchange comprises a central concentrator for directing signals from predetermined external network ports to predetermined sequentially repetitive time slots in a bit stream generated by the central concentrator, and for directing signals to predetermined  
10 mined external network ports from predetermined sequentially repetitive time slots in a bit stream received by the central concentrator, and by the remote-connection processor directing signal transfer between given sequentially repetitive time slots of the communication channel.

15 The base station of the present invention is further characterized by the remote-connection processor preferably comprising a remote terminal concentrator, for directing signals from predetermined remote ports to predetermined sequentially repetitive time slots in a bit stream generated by the remote  
20 concentrator and transmitted to the central concentrator, and for directing signals to predetermined remote ports from predetermined sequentially repetitive time slots in the bit stream generated by the central concentrator, and by a buffer unit connected to the remote ports for directing signals between  
25 predetermined remote ports and predetermined communication channel time slots.

Because the exchange of the base station of the present invention communicates with the communication circuit by generating and receiving bitstreams as described above, it is practical to locate the exchange of the base station of the present invention remotely from the communication circuit of the base station since the bitstream may be transmitted between the exchange and the communication circuit over appreciable distances by microwave.

#### GLOSSARY OF ACRONYMS

10	ACK	Acknowledge
	AMI	Alternate Mark Inversion
	BCC	Base-station Control Channel
	BEC	Bit Error Count
	CCU	Channel Control Unit
15	CCT	Channel Control Task
	CM	Channel Module
	CO	Central Office
	COT	Central Office Terminal
	CPU	Central Processing Unit
20	CRC	Cyclic Redundancy Check
	EEPROM	Electrically Erasable Programmable Read Only Memory
	EPROM	Electrically Programmable Read Only Memory
	FCS	Frame Check Sequence
	FIFO	First In First Out
25	HEX	Hexadecimal
	LSB	Least Significant Bit
	MPM	Message Processing Module

	MSB	Most Significant Bit
	MTU	Master Timing Unit
	MUX	Multiplexer
	MTMU	Master Timing & Multiplexer Unit
5	NRZ	Non-Return to Zero
	OCXO	Oven Controlled Crystal Oscillator
	PCM	Pulse Code Modulation
	PLL	Phase Locked Loop
	RAM	Random Access Memory
10	RCC	Radio Control Channel
	RPU	Remote-connection Processing Unit
	RRT	Remote Radio Terminal
	RX	Receive
	RZ	Return to Zero
15	SCT	Subscriber Control Task
	SDLC	Synchronous Data Link Control
	SID	Subscriber Identification
	SIDX	Subscriber Index
	SIU	Serial Interface Unit
20	STAD INIT	Station Address Initialization
	TC	Terminal Count
	TDM	Time Division Multiplexed
	TTL	Transistor-transistor Logic
	TX	Transmit
25	UART	Universal Asynchronous Receiver Transmitter
	UW	Unique Word
	VCU	Voice Codec Unit

VCXO        Voltage Controlled Crystal Oscillator  
ZBI        Zero Bit Insertion

#### BRIEF DESCRIPTION OF THE DRAWINGS

5        Fig. 1 is a block diagram of a preferred embodiment of the base station of the present invention.

      Fig. 2 is a block diagram of a buffer unit included in the buffer of the base station of Fig. 1 for interfacing with a single channel module.

10       Fig. 3 is a state diagram illustrating normal call processing flow in the base station of Fig. 1.

      Fig. 4 is a block diagram of the expanded embodiment of the base station of the present invention.

      Fig. 5 is a block diagram of a MUX card included in the base station shown in Fig. 4.

15       Fig. 6 is a diagram showing the normal call processing logic flow ordered by the RPU in the base station of Fig. 4.

      Fig. 7 is a functional block diagram of the exchange/RPU interface unit in the base station of Fig. 4.

20       Fig. 8 is a block diagram showing further details of the connections of the exchange and the RPU to the exchange/RPU interface unit in the base station of Fig. 4.

      Fig. 9 illustrates the layers of communications between the base station of Fig. 1 and each subscriber station.

25       As shown in Fig. 1, there is shown an exchange 10, a communication circuit 12 and a remote control processor 14, the circuit 12 and processor 14 being located remotely from the exchange 10.

The exchange 10 includes a two-to-four wire converter 16, a signalling data converter 17, an echo canceller 18, and a central concentrator 19. The communication circuit 12 includes a plurality of channel modules 21a, ..., 21n. Each channel module 21 includes a voice codec unit (VCU) 23, a channel control unit (CCU) 24 and a modem 25. The remote-connection processor 14 includes a remote concentrator 27 and a buffer unit 28.

Referring to Fig. 2, the buffer unit 28 includes a timing generator 30 and a channel interface module 32.

Referring again to Fig. 1, the exchange 10 is connected to a plurality of ports of a central office 35 by  $N$  pairs of lines 37. "N" is the number of subscriber stations being served by the base station. Each pair of lines 37 provides a 2-wire loop appearance. Each line pair 37 is connected to both the two-to-four wire converter 16, and the signalling data converter 17. Unidirectional signal flow takes place on the line pairs 38-41 on the other sides of the converters 16, 17, with 4-wire loop appearances being provided on the combination of  $N$  line pairs 38 and  $N$  line pairs 39. Transmitted voice signals are provided on line pairs 38; received voice signals are provided on line pairs 39; transmitted signalling data is provided on line pairs 40; and received signalling data is provided on line pairs 41.

The transmitted and received voice signals are communicated between the two-to-four wire converter 16 and the central concentrator 19 through the echo canceller 18. The signalling data is communicated directly between the converter 17 and the central concentrator 19.

The central concentrator 19 is a Model 1218C concentrator sold by ITT Corp.

5 The central concentrator 19 directs signals from predetermined line pairs 38-41 (which are connected to predetermined external network ports in the central office 35) to predetermined sequentially repetitive time slots in a bit stream generated by the central concentrator 19. The central concentrator 19 also directs signals to predetermined external network ports in the central office via predetermined line pairs 38-41  
10 from predetermined sequentially repetitive time slots in a bit stream received by the central concentrator 19. The central concentrator transmits and receives such bit streams via a microwave antenna 43.

15 These bit streams are communicated between the antenna 43 and a microwave antenna 44 connected to the remote concentrator 27 contained in the remote-connection processor 14. The remote concentrator 27 has a plurality of remote ports connected to the buffer 28 by line pairs 46-49.

20 The remote concentrator 27 is a Model 1218S concentrator sold by ITT Corp.

25 The remote concentrator 27 directs signals from predetermined remote terminals (which are connected to predetermined line pairs 46-49) to predetermined sequentially repetitive time slots in a bit stream generated by the remote concentrator 27. The remote concentrator 27 also directs signals to predetermined remote ports from predetermined sequentially repetitive time slots in the bit stream received by the remote concentrator 27 from the central concentrator 19.

The transmitted voice signals are provided on line pairs 46; the received voice signals are provided on line pairs 47; the transmitted signalling data is provided on line pairs 48; and the received signalling data is provided on the line pairs 49.

The buffer 28 interfaces the remote concentrator 27 with the communication circuit 12.

As described above, the communication circuit 12 includes a plurality of channel modules 21. Each channel module 21 communicates with a given number of subscriber stations 51 over a given communication channel having an assigned frequency and further having multiple sequentially repetitive time slots. Communication between each channel module 21 and the subscriber stations 51 is via a microwave link between a base station antenna 53 and antennas 54 located at each subscriber station. Predetermined time slots are assigned to predetermined subscriber stations 51. In the preferred embodiment, there are three subscriber stations 51 coupled to each channel module 19 over each discrete frequency communication channel. Each subscriber station 51 has a telephone connected thereto.

In each channel module 21, the VCU 23 includes a separate voice codec (not shown) for each subscriber station 51 and an additional codec for communicating signalling data to and from all three subscriber stations. The CCU 24 assigns the signals communicated through the codecs of the VCU 23 to different time slots of the communication channel assigned to the given channel module 21. These signals are communicated between the CCU 24 and the base station antenna 53 via the modem 25 and additional signal conditioning components (not shown)

adapted for transmitting and receiving these signals over the discrete communication channel at the assigned frequency. Thus, each subscriber station 51 communicates voice signals with the base station over its own predetermined time slot and communicates signalling data with the base station over a predetermined time slot that is common to all three subscriber stations. Communication between the base station and the subscriber stations is controlled by a radio control unit (RCU) software process implemented by a microcomputer in the CCU 24.

10           The RCU is programmed to recognize three predetermined subscriber stations corresponding to three predetermined line appearances provided by the connections between the remote concentrator 27 and a given channel module 21.

15           Control processing in the RCU is organized using state machines. Input message tokens include signalling data from the remote concentrator 27, radio control channel (RCC) messages from the subscriber stations, and (simulated) baseband control channel (BCC) messages.

          This routine changes the channel state to Syn Ring.

20           The buffer 28 is connected to the remote ports of the remote concentrator 27 via line pairs 46-49 and to the channel modules 21 of the communication circuit 14 via lines 57 for directing the transmitted and received voice signals between the predetermined remote ports of the remote concentrator 27 and the predetermined communication channel time slots assigned to predetermined subscriber stations 51. The subscriber stations 51 are located remotely from the base station.

The buffer 28 includes a separate buffer unit, as shown in Fig. 2, for interfacing with each channel module 21 in the communication circuit 12. The timing generator 30 provides the channel interface module 32 with a clock signal CLK and four gate signals Gate 0, Gate 1, Gate 2, Gate 3 for defining four sequentially repetitive time slots in the assigned communication channel.

The transmitted voice signal line pairs 46, the received voice signal line pairs 47, and the signalling data line pairs 48, 49 are connected between the remote ports of the concentrator 27 and the channel interface module 32.

The channel interface module 32 provides the clock and gate signals to the channel module 27 for defining the time slots assigned by the CCU 24.

The channel interface module 32 is connected to the VCU 23 in the corresponding channel module 21 in a predetermined manner for directing communications between line pairs 46, 47 carrying transmitted and received voice signals associated with a given subscriber station and a codec in the VCU 23 having the predetermined communication channel time slot assigned by the CCU 24 to the given subscriber station. The channel interface module is further connected to the VCU 23 for directing and signalling data between the signalling data line pairs 48, 49 and the voice codec in the VCU having the common time slot assigned by the CCU 24 for communicating signalling data for all three subscriber stations associated with the given channel module.

The embodiment of the invention illustrated in Figs. 4-9 is an expanded version of the system described above. In this expanded form, the exchange is responsive to a command from the remote-connection processor for causing a signal received by the exchange from one of the communication signal processors over a given time slot to be looped back to the communication signal processor coupled to that time slot. Each communication signal processor is coupled to one of the channel control units in response to a looped-back predetermined signal pattern to enable the coupled channel control unit to receive commands from the remote-connection processor for assigning the communication signal processor that receives the looped-back predetermined signal pattern to communicate with a given subscriber station.

The communication circuit may include a plurality of trunks for providing a plurality of communication channels. A plurality of multiplexers are coupled to the plurality of trunks for providing multiple sequentially repetitive time slots in each of the communication channels, thereby enabling simultaneous communications between a plurality of the ports and a plurality of the subscriber stations over the communication channels. A plurality of channel control units are coupled to the multiplexers for coupling assigned time slots to given subscriber stations. A plurality of controllers are respectively coupled to the multiplexers and a local bus is provided between the controllers and the channel control units.

In accordance with the monitored status, the remote-connection processor selects one of the time slots to carry the base-station control channel and causes the controller that is

coupled to the multiplexer that is coupled to the trunk that carries the time slot selected to carry the base-station control channel to function as a primary controller for coupling the base-station control channel over the local bus to the other  
5 controllers and to the channel control units, thereby enabling the remote-connection processor to monitor the status of the other time slots and to assign the other time slots.

The communication circuit may, optionally, include a plurality of trunks for providing a plurality of communication  
10 channels and a plurality of multiplexers coupled to the plurality of trunks for providing multiple sequentially repetitive time slots in each of the communication channels, thereby enabling simultaneous communications between a plurality of the ports and a plurality of the subscriber stations over the  
15 communication channels. A plurality of channel control units may be coupled to the multiplexers for coupling assigned time slots to given subscriber stations, with each channel control unit coupling a plurality of assigned time slots to a corresponding plurality of subscriber stations. The assignment  
20 routine in this arrangement includes assigning all of the time slots associated with any given channel control unit before assigning time slots associated with another channel control unit, and then assigning time slots associated with a channel control unit coupled to a different multiplexer than the multi-  
25 plexer coupled to the channel control unit associated with the previously assigned time slots.

This base station is, therefore, capable of handling a large number of communications involving a large number of subscriber stations with great flexibility.

Referring to Figure 4, the base station includes a central office terminal (COT) 110 and a remote radio terminal (RRT) 111. The COT 110 includes a concentrator 113, a remote-connection processor unit (RPU) 114, a concentrator/RPU interface unit 115, and a plurality of echo canceller units 116. The RRT 111 includes a master timing unit (MTU) 118, a plurality of multiplexers (MUXs) 119, a plurality of channel modules 120, a plurality of power amplifiers 121 and a transmitter/receiver network 122. Each of the channel modules 120 includes a channel control unit (CCU) 123.

The concentrator 113 communicates with a telephone company central office 125 over a plurality of two-wire-appearance lines 126. The concentrator 113 communicates with the MUXs 119 in the RRT 111 over a plurality of span trunks 128. Each of the span trunks 128 carries digital information in a plurality of multiplexed time slots provided by the respective MUX 119 to which the span trunk 128 is connected. The number of time slots is smaller than the number of appearances, thereby producing a concentration of external circuits. The ratio of appearances to time slots is the same as the ratio of subscribers to time slots. The device providing the first ratio is referred to as an "exchange", or specifically in the present instance as a concentrator. The device providing the second

ratio is referred to as an "expander" which comprises the remote radio terminal (RRT), the subscriber stations and the RPU which acts as a control for both the RRT and the subscriber stations.

5 The digital information may be voice data or other data. The voice data coding technique is digital information. Voice signals carried over the span trunks 128 are passed from and to the concentrator 113 through the echo cancellers 116 in the COT 110.

10 The MTU 118 provides timing signals to the MUXs 119 over a timing bus 130.

The RPU 114 is coupled by the concentrator 113 to the MUXs 119 for communicating with the MUXs 119 and the CCUs 123 over a base-station control channel (BCC), which occupies one of the time slots on one of the span trunks 128 and which is  
15 coupled between the MUXs 119 and the CCUs 123 by a local BCC bus 132. The BCC channel between the RPU 114 and the concentrator 113 is provided by lines 134 between the RPU 114 and the concentrator/RPU interface unit 115 and by lines 135 between the concentrator/RPU interface unit 115 and the concentrator 113.

20 Each of the MUXs 119 is connected to a plurality of the channel modules 120 by a plurality of separate lines 137. A plurality of voice and data channels are provided over each of the lines 137 for communicating with a plurality of subscriber stations 141 through each of the channel modules 120. Each of  
25 the channel modules 120 is coupled to the transmitter/receiver network 122 by one of the power amplifiers 121 for communicating with a plurality of subscriber stations 141 over a corresponding plurality of time slots in an RF channel.

The RRT 111 can in some installations be colocated with the COT 110. In these types of installations, the span trunks 128 are standard twisted-pair cables which are used to connect the RRT 111 to the COT 110. Due to the fact that the RRT 111 requires a somewhat line-of-sight path to the subscriber stations 141, a more typical installation of the RRT 111 is remote from the COT 110 and occupies a high point in the surrounding terrain. In this case, a microwave, fiber optic, or long cable link is used to provide the transmission medium between the COT 110 and RRT 111.

Each span trunk 128 is a T1 trunk that is capable of carrying a time-division-multiplexed (TDM) DS1 signal. The DS1 signal provides 24 time slots, each containing one byte of digital information. Therefore up to 24 simultaneous circuits can be supported by one span trunk 128. The MUXs 119 establish frame timing in order to demultiplex the digital information. Once frame timing is established, the individual bytes can be extracted for the appropriate channel modules 120.

Each channel module 120 supports one UHF RF channel. Each RF channel in turn is divided into four usable time slots. Accordingly one RF channel can support simultaneous circuits with up to four subscriber stations. Since each span trunk 128 can support up to 24 simultaneous circuits, each MUX 119 must be able to communicate with up to six channel modules 120.

Each of the MUXs 119 is embodied in a modular card that is capable of handling up to 24 simultaneous circuits only or 23 simultaneous circuits plus the BCC. The MUXs 119 include the hardware required to extract the data from the trunks 128

and to distribute it to the channel modules 120. The MUX card 119 provides all of the necessary timing signals for the channel modules 120 to extract the correct digital information. Each MUX card 119 contains the circuitry needed to transmit and receive a DS1-format waveform and provide sufficient drive capability for the maximum span trunk 128 length.

The base station may contain up to six MUX cards 119 and therefore provides the capability of supporting up to 36 RF channels.

The concentrator 113 comprises a Model 1218C digital image concentrator provided with a switch; this unit being available from ITT Corporation of New York, New York, USA.

The RPU 114 comprises an Alcyon computer available from Alcyon Corp. of San Diego, California. The RPU 114 has ultimate control of both the concentrator 113 and the RRT 111. The RPU 114 processes subscribers' requests to set up the required transmission path between the subscriber stations 141 and the central office 125.

To support the BCC bus 132, each MUX card 119 contains a microcontroller 144 with a built-in synchronous data link control (SDLC) controller. Hardware in the MUX card 119 can remove and insert data in the BCC, which occupies the first channel of the DS1 data stream of one of the span trunks 128. This data is processed by the microcontroller which then generates the appropriate messages on the BCC bus 132 to effect any commands issued over the BCC by the RPU 114. Only one MUX card 119 out of the possible six in the base station receives the BCC from the RPU 114 at any given time. Only this card will insert

data into the first channel of a selected span trunk 128, as well as provide the primary microcontroller for the BCC bus 132. This MUX card is referred to as the primary MUX card. The remaining MUX cards 119 allow the respective first channels of the span trunks to which they are connected to be used as a digital information slot for a channel module 120 and configure their microcontrollers to act as BCC bus secondaries. The primary MUX will also provide appropriate signals to control the MTU 118 as well as to receive status messages that are provided to the RPU 114 over the BCC occupying the first channel of the span trunk 128 connected to the primary MUX card.

A block diagram of a MUX card 119 is shown in Figure 2. The MUX card 119 includes a transceiver 143, a microcontroller 144, a unipolar converter 145, a clock extractor 146, a bipolar converter 147, a span loopback MUX 148, an elastic buffer 149, a frame buffer 150, a receive (RX) first-in-first-out FIFO stack 152, a transmit (TX) FIFO stack 153, a register 154, a byte filter 155, an RX channel counter 156, a TX channel counter 157, a VCU gate generator 158, a gate driver 159, a parallel-to-serial converter 160, a line driver 161, a line receiver 162, a serial-to-parallel converter 163, an electrically programmable read only memory (EPROM) 164, clock receivers 166, a clock driver 167, and a slip control unit 168.

Four major interfaces are provided to each MUX card 119.

The trunk 128 provides a 1.544 Mbps bi-directional path for all data between the COT 110 and the RRT 111.

Voice codec units (VCUs) in the channel modules 120 are interfaced with each mux card 119 by digital information data channels 137a, 137b, which provide a serial 1.544 MBPS bit data stream, and by clock line 137c and gate lines 137d, which  
5 provide appropriate clock and gate signals to allow the VCUs to extract and insert 64 KBPS/channel digital information in the correct time slot. Up to six VCUs can be supported by this interface.

The BCC bus 132 provides the control and status data  
10 between all of the channel modules 120 and MUX cards 119 in the RRT 111. The protocol used on the BCC bus 132 is SDLC multidrop with a polling of all secondary MUX cards 119 and all channel modules 120 by a single primary microcontroller 144 in the primary MUX card 119. A redundant BCC bus (not shown) may be  
15 provided as a backup.

Clock signals are received on lines 130 from the master timing unit 118.

The electrical interface to the T1 span trunks 128a, 128b provides those functions required to generate or receive a  
20 DS1 waveform. The interface is designed to meet the interconnection specifications for a signal appearing at a DSX-1 cross-connect (ref. AT&T Compatibility Bulletin #119). This specification allows up to 655 feet of ABAM (or equivalent) cable to connect the RRT 111 to the appropriate transmission  
25 equipment or to the COT 110 directly.

In the receive path 128a, the unipolar converter 145 converts a bipolar alternate mark inversion (AMI) RZ signal to a unipolar TTL NRZ signal for input to the transceiver 143. The

clock extractor 146 extracts a clock from the input signal which is used to clock the NRZ data and can optionally be used as reference clock for an external phase locked loop (PLL) which would generate the 1.544 MHz input clock. The extracted clock signal is provided on line 172.

In the transmit path the bipolar converter 147 converts the TTL NRZ signal into a DS1 bipolar/AMI signal. The span loopback MUX 148 is provided to loop back the complete DS1 signal.

The transceiver 143 contains the appropriate circuitry for synchronization, channel monitoring and signalling insertion and extraction. The transceiver 143 is preferably a Model R8070 T-1 transceiver available from Rockwell International Corp. of Pittsburgh, Pennsylvania, USA.

The transceiver is preferably a multipurpose device and as such it supports various North American and European primary-rate digital protocols. The mode which is compatible with the concentrator 113 is the "193S". This mode provides 193 bits/frame, with A,B signalling; 12 frames per superframe; and zero suppression using B7 (2nd LSB) stuffing. The DS1 frame organization provides a sampling frequency of 8000 Hz.; an output bit rate of 1.544 Mbits per second; 193 bits per frame; and 24 time slots per frame. Signalling is provided by the eighth bit of every sixth frame, the S-bit being time shared between terminal framing and signalling framing.

The transceiver 143 used herein provides independent transmit and receive sections, allowing each section to operate with different clocks and framing. A 1.544 MHz clock generated

by and received from the MTU 118 by the clock receivers 166, via lines 130, is coupled to the transceiver 143 via line 170 and used as the transmit clock. The 1.544 clock received by the clock receivers 166 is also coupled to the VCUs on line 137c by the clock driver 167. The receive path of the transceiver 143 uses the extracted clock signal on line 172 from the clock extractor 146 up to the elastic buffer 149. After this point, a local clock provided by the clock receivers 166 on line 171 is used.

10           The concentrator 113 in the COT 110 is programmed to derive its transmit bit timing from the received DS1 signal (loop timed). This in effect makes the DS1 input and output bit rate identical.

15           A 80 MHz OCCO in the MTU 118 is used as the primary clock from which all other timing is derived including the 1.544 MHz local clock.

20           The subscriber stations 141 lock their local VCXO's onto the UHF RF signal transmitted by the base station and therefore generate local timing which is directly related to the base station timing. This results in a completely synchronous system so that the digital information rate generated by the subscriber stations 141 exactly equals the data rate provided by the T1 trunk 128. In this configuration, data is not accumulated or depleted over time so controlled slips are not required.

25           In a MUX-sources timing mode of operation, the COT 110 is slaved to extracted DS1 receive timing; the DS1 transmit path 128b is referenced to the MTU OCXO; the DS1 receive path 128a is referenced to the MTU OCXO (via loop timing); the VCU-PCM

interface 137 is referenced to the MTU OCXO; and the VCU is referenced to the MTU OCXO. In this mode the total system is synchronized, and no controlled slipping has to be done.

5 Although the transmit and receive DS1 rates are equal on the average due to the slaving of one direction to the other, jitter can occur in the received waveform which can make this signal look instantaneously like a higher or lower rate. Also, due to the unknown path delay and unknown delay in the concentrator 113, the local clock and regenerated receive clock have  
10 an unknown skew between them. To compensate for these two effects, a 16-byte elastic buffer 149 is connected to the transceiver 143. Bytes are loaded into this buffer 149 at a rate determined by the extracted receive clock signal on line 172. Data is extracted at a rate determined by the local clock signal  
15 on line 171. The elastic buffer 149 is coupled to the RX FIFO 152 stack by the byte filter 155 so that the independent shift-in and shift-out clocks can be provided.

If the transceiver 143 loses frame alignment, data loading into the elastic buffer 149 is inhibited to prevent  
20 invalid data from being sent to the VCUs and the microcontroller 144. During out-of-frame conditions, data is still sent to the VCUs, but this data is forced to FF(HEX), which corresponds to an analog "zero" level. Once frame alignment has been re-established, data is again loaded.

25 The frame buffer 150 is provided to allow the DS1 transmit and receive paths 128b, 128a to operate independently. Due to such independence, transmit and receive frames are not necessarily in alignment. However, the interface 137 to the VCU

is designed such that for a given channel, the transmit and received data is sent simultaneously, implying frame alignment from the VCU's perspective. The frame buffer 150 resolves this dilemma by providing separate read and write pointers which  
5 allow the writing of data into the frame buffer 150 to be based on the transceiver receive frame alignment and the reading of data to be based on the transmit framing. The transmit framing is used on the VCU interface 137 thus allowing the transmit and receive byte for a given channel to occur simultaneously on the  
10 VCU interface 137.

The frame buffer 150 contains four frames worth of data. The addressing is such that a fixed address within each of the four buffers corresponds to a fixed channel assignment. The read and write pointers are initially set two buffers apart.  
15 Once RX framing is acquired, the write pointer follows the RX framing which means that it may point at a different byte (i.e. channel) in its current buffer than the read pointer. Having a two-buffer initial separation ensures that the pointers will initially never be closer than 1 frame (e.g. Read at the end of  
20 frame 1, and Write at the beginning of frame 3). This separation allows a large amount of jitter to occur on the receive data without the write pointer crossing the read pointer. It also simplifies the slipping function which is explained below.

Reads and writes of the frame buffer 150 are slaved to  
25 the transmit clock. Only one read of the frame buffer 150 is performed every eight bit times of the transmit clock since the VCU interface 137 is under control of this clock. However, the receive path is under control of the extracted clock signal on

line 172 up to the elastic buffer 149. To guarantee that data does not build up in the elastic buffer 149, the frame buffer 150 control logic allows up to two writes to be performed during the same eight bit times of the transmit clock.

5           A secondary function of the frame buffer 150 is that it allows controlled slips to be performed in the receive direction. Under normal conditions, this should never occur when operating with the concentrator 113, as explained previously; and is therefore considered a fault condition. If the timing of  
10 the concentrator 113 drifts (loses lock) or if the DS1 input on input trunk 128a is lost, the data rate into the frame buffer 150 could possibly change. If this condition lasts for sufficient time such that the read and write pointers overlap, then a controlled slip is performed. The slip moves the appropriate  
15 pointer such that one frame of data is either repeated or deleted. When this occurs, receive framing will not be lost if the DS1 input is still present. To simplify the comparing of the pointers, this function is only active during the Terminal Count (TC) of either pointer. Terminal Count is defined as the  
20 end of the current buffer. The slip control unit 168 keeps track of the number of TCs reached by both the read pointer and the write pointer in response to TCs provided by the RX channel counter 156 and the TX channel counter 157. If the read pointer passes the write pointer then a frame of data will be repeated.  
25 If the write pointer passes the read, then a frame of data will be deleted. The indication of a slip is latched by the slip control unit 168 and provided on line 174 to the microcontroller 144.

The microcontroller 144 is interfaced with the transceiver 143 by a data bus 176 and two 16-byte FIFO stacks 152, 153, which provide a buffer for both transmit and receive BCC data. BCC data is extracted from the RX FIFO stack 152 during the first DS1 time slot; and BCC data is inserted into the TX FIFO stack 153 during the first DS1 time slot. Transmit BCC data is inserted if commanded by the microcontroller 144 by the setting of a control bit.

The RX FIFO stack 152 buffers messages from the RPU 114 that have been transmitted over the T1 trunk 128 to the MUX card 119 that is the primary controller of the BCC bus 132. The format of the message bytes is such that bit 3 is designated as a sequence bit. This bit normally toggles on every byte transmitted by the RPU 114. One channel on the T1 trunk 128 can carry 64 KBPS (56 KBPS usable) however, the RPU 114 can not supply data at this rate. The sequence bit allows the MUX card 119 hardware to discard those bytes sent which are simply a repeat of the previous byte. Repetition occurs whenever the data buffer written by the RPU 114 becomes depleted. Repetition has no effect since the byte filter 155 placed before the receive FIFO stack 152 eliminates those bytes which have the same sequence bit.

The RX FIFO "output ready" status, which is readable by the microcontroller 144, indicates that at least one byte is in the RX FIFO stack 152. To prevent an RX FIFO overflow condition from occurring, an "RX FIFO FULL" signal is generated and provided on line 177 to interrupt 0 of the microcontroller 144. The microcontroller 144 then has one frame time (125 usec) to

read at least one byte from the RX FIFO stack 152 before an overflow occurs. Since the RX FIFO stack 152 is 16 bytes deep, it takes a minimum of  $16 \times 125 \text{ usec} = 2 \text{ msec}$  to fill an empty RX FIFO stack 152.

5           The TX FIFO stack 153 provides a buffer from the MUX card-to-RPU BCC channel communication. The register 154 extracts data from the TX FIFO stack 153 and inserts it into the first DS1 channel 1 when enabled by the microcontroller. The TX FIFO stack 153 status is readable but does not generate any  
10 interrupts. Like the receive path, the alternating sequence bits allow the TX FIFO stack 153 to empty even in the middle of a message without causing any errors. When empty, the TX FIFO stack 153 simply repeats the last byte and this repetition of data will be discarded by the interface to the RPU 114 because  
15 the sequence bit will be unchanged. This repetition feature is also useful for sending idle patterns (if used). The microcontroller 144 only has to load the idle pattern once into the TX FIFO stack 153 and it will be repeated until another byte is loaded.

20           The VCU Interface 137 provides the path for digital information to and from the VCU. The data is sent serially at the same rate as the DS1 data, namely 1.544 MBPS. Each VCU sends and receives data for four contiguous slots of the DS1 frame. The four bytes transmitted and the four bytes received  
25 occur simultaneously. In order for a VCU to identify its four time slots, a GATE is provided on line 137d by the MUX card 119. This gate lasts for four bytes and a separate gate is generated for each VCU. Each particular signal (e.g. GACLAIMSTEL, GATE2,

etc.) is hardwired to a particular VCU. Each VCU contains four voice codec processors. Each VCU multiplexes the four voice codec processors in response to its respective gate signal.

5 All four bytes from one VCU will follow one another contiguously. Each byte will be converted to parallel by the serial-to-parallel converter 163 and then input to the transceiver 143. This process continues normally for most channel time slots. However, when the transceiver 143 is transmitting the twenty-fourth channel of data, it extends the cycle by one  
10 clock to account for the frame bit time. It is desired that this extended time slot occur at the end of a gate because a VCU expects its four bytes to be contiguous and can not account for a gap in the transmit timing. Moving the gap to the end of a VCU cycle allows the gap to occur between GATES and therefore  
15 has no effect. Due to pipelining and synchronous delays, when the Model R8070 transceiver 143 is transmitting the twenty-fourth channel of data, the second channel of data is active on the VCU interface 137.

The GATE signals 137d actually lead the data slightly  
20 to allow the VCU 124 to initialize its interface logic.

All of the VCUs share a common serial return data bus 137b. Drivers for each VCU are tri-stated when not selected by the gate. Therefore only one VCU drives the bus 137b at any one time. In some installations, less than six VCUs may actually be  
25 connected to a MUX card 119. To define the serial data when no VCU is driving the VCU return data bus 137b, pull up and pull down resistors are provided on the MUX card line receiver 162, which will define the data to be all ones.

The microcontroller 144 performs various functions on the MUX card. It is responsible for initializing all hardware as well as monitoring status and errors. Also, the microcontroller 144 on one of the MUX cards 119 is selected by the RPU 114 as the primary controller for controlling the BCC bus 132. The MUX card 119 containing the primary controller is considered to be the primary MUX card 119. Control of the BCC bus 132 involves the continual polling of all channel modules 120 (via their CCUs) and all other MUX cards 119 which are treated as secondary MUX cards. The secondary MUX cards still perform the other functions described above for their respective channel modules 120.

The microcontroller 144 is preferably a Model 8344 microcontroller available from Intel Corporation of Santa Clara, California, USA. The microcontroller 144 includes a built-in serial interface unit (SIU) which supports the SDLC protocol. The microcontroller 144 contains communication hardware to help free up the microcontroller processor core from having to interact with every event that happens on the BCC bus. The SIU interrupts the processor core only when a message has been transmitted or received.

All program memory resides externally in the EPROM 164. Data memory consists of 4K bytes externally and 192 bytes of internal RAM. A watchdog timer (not shown) is provided to reset the microcontroller 144 if an abnormal event occurs which prevents the microcontroller 144 from normal operation. The occurrence of a watchdog reset will be latched and thus allow the microprocessor 144 software to verify the occurrence of that event.

The MUX card 119 which is designated primary by the RPU 114 is responsible for controlling the MTU 118 and reporting its status to the RPU 114. Such controls consists of four lines which are mapped into four bits of a register (not shown). The  
5 outputs of the register are connected to tri-state drivers (not shown). All MUX cards are wired to four pairs of common lines but only one set of drivers are enabled at a given time. All timing of these signals is under software control.

Each MUX card 119 can perform a hardware reset of a  
10 channel module 120. This would normally be commanded by the RPU 114 if a channel module 120 goes into an undefined state.

The concentrator 113 and the RPU 114 are coupled via a 64 Kbit/sec DS0 channel, which is referred to as the data link 180, 181. The DS0 interface at the RPU 114 is supported by a  
15 DS0/DP circuit card in the concentrator 113 and the concentrator/RPU interface unit 115.

The RPU 114 controls the assigning of time slot connections, and must maintain communications with the concentrator 113 over the data links 180, 181 in order to provide a path to  
20 receive connection requests and to send connection assignments. The data link 180, 181 are also used to transfer status, test and alarm messages between the RPU 114 and the concentrator 113.

The BCC channel is used by the RPU 114 to control and configure the RRT 111 hardware to monitor status and to transmit  
25 and receive call processing information.

The digital span trunks 128 between the COT 110 and the RRT 111 are 1.544 MB T1 compatible. The signalling format and electrical characteristics are defined by AT&T Technical

Advisory No. 32, "The D3 Channel Bank Compatibility Specification - Issue 3, October, 1977".

The electrical interface of the digital data ports of the Model 1218C concentrator 113 is defined by ITT document  
5 628340-001-301 "Performance Specification, DSO Dataport (DSO/DP)".

During system initialization and whenever the data link 180, 181 is lost, the RPU 114 and the concentrator 113 execute a data link assignment algorithm to (re)establish the  
10 link. The data link 180, 181 is considered lost if no message is transferred during a 200 msec period, or if either the concentrator 113 or the RPU 114 sends an abandon (ABN) control character over the data links 180, 181. The data links 180, 181 are assigned to one of two line group and line circuit combinations of the concentrator 113. A verification procedure  
15 establishes that the new data link is found. If the data link is not (re)established within two seconds, both the concentrator 113 and the RPU drop all traffic and restart the algorithm. The algorithm is initiated by the RPU 114, which sends a PDL control  
20 character on each of the two channels of the data link 180. The concentrator scans these two channels for a character, and responds by sending the PDL character back over the first channel the character was detected on. The RPU 114 responds with an ACK signal, and the standard acknowledgement sequence is  
25 initiated by the control unit of the concentrator.

Data is transferred over the BCC channel 135 lines in the form of serial, synchronous (8 bit) byte information. The sampling frequency for information transfer is 8 KHz.

The RPU 114 contains a software-implemented message processing module (MPM) (not shown), which performs high-level call processing functions between the concentrator 113 and the subscriber stations 141. The MPM is responsible for call processing functions such as handling of incoming calls from the concentrator 113 and call requests from the subscriber stations 141, and the resulting allocation of voice channels. The MPM is responsible for processing status and error messages received from the CCUs 123, the MUX cards 119, the concentrator 113 and the subscriber stations. Some operator commands involving the CCUs 123, the MUX cards 119 and the subscriber stations are also passed on to the MPM for handling. Finally, the MPM performs the initialization of the system configuration (the T1 span trunks 128, the MUX cards 119, and the CCUs 123), along with any necessary background recovery and maintenance of the configuration.

With regards to the call processing functions, the MPM is organized as a state machine wherein the concentrator, RCC and BCC messages are tokens to the message processing state machines. The MPM processes the tokens by updating the database, sending the necessary message responses, and then transitioning to the next state.

The MPM uses system mailboxes, which are maintained by a software-implemented scheduling module in the RPU 114, to receive and transmit messages to and from external sources indirectly via modules which interface with the external equipment.

Also, the MPM utilizes subroutines in a database module in the RPU 114 to retrieve or update state information in the database.

5 The MPM is responsible for initializing and maintaining the system configuration. This involves establishing and maintaining the primary MUX card so that communication with the RRT 111 is possible, initializing secondary MUX cards based on the DS1 span status of the T1 span trunks 128, initializing the CCUs 123 based on the configuration given by the operator, and  
10 making sure that a the RCC is assigned whenever possible.

When the MPM performs initialization for the first time, it attempts to find which T1 trunks 128, MUX cards 119 and CCUs 123 are present in the system, and selects one of the MUX cards 119 as the primary MUX card in accordance with the follow-  
15 ing predetermined selection routine.

Initialization can begin only after the concentrator 113 has informed the MPM of the status of each T1 span trunk 128, at which time the MPM updates the database appropriately. The MPM must know which T1 span trunks exist to determine which  
20 MUX cards 119 are to be initialized, and consequently which MUX card is to be assigned as the primary MUX card. Only when all T1 span trunk status is known and at least one T1 span trunk 128 is up, does initialization proceed.

The MPM establishes a connection with the MUX card  
25 corresponding to each T1 span trunk 128 that is up, by assigning a trunk connection via a DS0/DP card using the first DS0 channel of the span trunk 128. Each MUX card is sent a hard-reset command over this channel, and the trunk 128 is deassigned.

After waiting for the MUX card 119 hard-resets to be completed, connections are again established with the MUX cards 119 one at a time, and each MUX card 119 is assigned as a primary. This primary MUX card assignment is required since a MUX card 119 can communicate via the BCC link over the T1 span trunk 128 only when it is in the primary state.

If the MUX card indicates that it has successfully become primary MUX card and it is reporting the correct MUX card station address (which must correspond to the DS1 span number), it is placed in the polling configuration and marked as "ready" in the database. The MUX card 119 is then set back to secondary, and the trunk 128 is deassigned. Once all MUX cards 119 have been initialized in this way, one is selected to become the primary MUX card. If more than one MUX card has been found, the primary MUX card is sent a polling configuration containing all the MUX cards in the configuration. The primary MUX card is responsible for performing the keep-alive protocol at the RRT 111 and informs the MPM whenever a polling error occurs. If no valid data has been received during this initialization procedure, the entire procedure is repeated using the redundant DSO/DP channel.

Once the MUX cards 119 have been initialized, the CCUs 123 corresponding to the MUX cards in the configuration are initialized. The number of CCU's defined in the system is determined by operator input, and the MPM will attempt to initialize only as many as are defined. First, for every MUX card in the polling configuration, the MPM commands all the associated CCUs 123 to be hard-reset. Since the MPM cannot communicate with the

CCUs 123 until they establish a station address on the BCC bus 132, the MPM must perform station address initialization (STAD INIT), which is described below.

5 If a CCU 123 is successfully initialized, it is placed in the polling configuration, and a timer is set to check that an event is received from that CCU 123. Once the MPM has reached the number of CCUs 123 defined, or has attempted to initialize all CCUs 123 corresponding to the MUX cards 119 that are in the configuration, a polling configuration message is sent to the primary MUX card for the initialized CCUs 123. Once this initialization is complete, the background process periodically attempts to find any missing CCUs 123 by the STAD INIT process.

15 When a CCU 123 is first polled by the primary MUX card, it responds with a Baseband Event message indicating any failures, its ready status, and the frequency it is set to. At this time the MPM marks the CCU as "ready" in the database if appropriate. The frequency is stored, each CCU channel is set to idle, and each corresponding DS0 channel is set to available. 20 If the database indicates that the modem is not set at maximum power, a message is sent to the CCU to set the attenuation level of the modem.

25 If the MPM has failed to establish a primary MUX card, a timer is set to reattempt initialization later. This first-time initialization procedure is executed periodically until the first primary MUX card is established, after which time the recovery procedure is used whenever the Primary MUX card fails.

Primary MUX card recovery is handled differently from the first time initialization, since the MPM already has information about which MUX cards 119 and CCUs 123 exist in the configuration, and it is critical to recover quickly so as not to  
5 loose voice calls. When a primary MUX card failure occurs, the primary MUX card and all its associated CCUs 123 are removed from the polling configuration. During recovery, the MPM attempts to assign a new primary MUX card connected to each T1 span trunk 128 that is up, provided no voice call is assigned on  
10 the first DSO channel of that trunk. On the first attempt, the last primary MUX card is avoided. If the MPM fails to initialize a primary MUX card and no valid data has been received during this procedure, the entire procedure is repeated using the redundant DSO/DP channel. If there is still no Primary MUX  
15 card, and there is a DS1 span with a voice call on the first DSO channel, the voice call is torn down and initialization is attempted. If the MPM still fails to initialize a primary MUX card, a timer is set to retry later.

If a new primary MUX card is successfully assigned, a  
20 polling configuration with the old primary MUX card and associated CCUs that were removed is sent to the new primary MUX card. An RCC is assigned if there currently isn't one; and each of the CCUs that were removed from the configuration are sent a reset command to clear out any outstanding voice calls or RCC assign-  
25 ment. If a call was torn down in the MPM database in order to assign the BCC channel, the CCU is informed of the disconnection.

It is assumed that if no messages are received from the CCUs, all ongoing voice calls are still in progress. While a CCU is not being polled, it queues up any new messages, which are then transmitted after polling resumes. If the queues overflow, the CCU informs the MPM of this once the primary MUX card resumes polling, causing the MPM to query each channel of the CCU to determine the current status.

An MPM background process is used to maintain and recover the system configuration. This includes (1) initializing secondary MUX cards whenever the corresponding T1 Span is up but the MUX card is not in the polling configuration; (2) initializing the CCUs if the number of CCUs in the polling configuration is less than what the operator has defined; (3) recovering DSO channels that have failed; and (4) keeping the concentrator informed of which line groups are in the configuration. The first three background tasks are performed only when there is a primary MUX card defined in the system, since they involve communication with the RRT 111.

Since the MPM cannot communicate with the CCUs until they establish a station address on the BCC bus, the MPM must perform station address initialization. Such initialization is performed by the MPM placing one of the DSO channels corresponding to the CCU into loopback. Since each VCU associated with an uninitialized CCU is continuously transmitting a unique pattern over the T1 trunk while idle, the VCU will detect the pattern on the forward channel during loopback and inform the CCU. After putting the channel into loopback, the MPM sends a STAD INIT message containing the appropriate station address

to the primary MUX card, which broadcasts it to all of the CCUs. Only uninitialized CCUs will respond to this message. The CCU that has detected the pattern takes that address for its own.

5 If the primary MUX card responds with a failure message, the MPM attempts initialization of that CCU on each of the available slots. Note that the slot corresponding to the BCC channel is not available, since the DSO channel used for the BCC channel cannot be put into loopback while being used for remote communication. Also, in some concentrators, because of a  
10 design nuance, a DSO channel cannot be put into loopback more than once in a row without putting another into loopback first, so if necessary the MPM skips the first slot in the initialization sequence to avoid this problem.

15 If the CCU 123 is successfully initialized, it is placed in the polling configuration, and the primary MUX card is sent the new configuration. A timer is set to check that an event is received from that CCU.

20 When a CCU 123 is first polled by the primary MUX card, it responds with a Baseband Event message indicating any failures, its ready status, and the frequency it is set to. At this time the MPM marks the CCU as "ready" in the database if appropriate. The frequency is stored, each CCU channel is set to idle, and each corresponding DSO channel is set to available. If the database indicates that the modem is not set at maximum  
25 power, a message is sent to the CCU to set the attenuation level of the modem.

At this point, the initialization of the CCU 123 is complete, and the CCU is ready to accept voice and RCC assignments.

5 When the MPM commands the concentrator 113 to assign a trunk, the concentrator initiates a pre-connection test. If this test fails either at the concentrator 113 or at the CCU 123, the MPM is informed and sets the DSO channel as failed in the database. In the background, the MPM continually attempts to recover any failed DSO channels.

10 When performing DSO channel recovery, the MPM scans the database for a failed DSO channel corresponding to a CCU 123 that is in the polling configuration and is idle on that slot. Due to the aforementioned design nuance, a DSO channel cannot be placed into loopback more than once in a row without putting  
15 another channel into loopback first. Therefore if the selected channel cannot be put into loopback for this reason, the MPM searches for another failed DSO channel if one exists, and performs recovery on the second one found. If no other failed channels exist, any idle channel is selected and put in and then  
20 out of loopback; and recovery of the failed DSO channel can then be attempted. If no idle DSO channels exist, the DSO channel recovery is not attempted, and the MPM waits for the background process to put another channel into loopback either via station address initialization or secondary MUX card initialization.

25 If a failed DSO channel has been selected, the MPM puts the channel into loopback and then sends a message to inform the corresponding CCU 123 that a DSO channel test is being performed on a particular slot. If the CCU response is

successful, the channel is marked as recovered in the database and loopback is removed. An alarm is triggered and cleared appropriately.

5 The MPM attempts to initialize a secondary MUX card whenever the corresponding T1 trunk is up but the MUX card is not in the polling configuration. An important factor in this initialization is to verify that the T1 span trunk 128 and the MUX card 119 are not crossed. In other words, the station address of the MUX card must match the T1 trunk number.

10 To initialize a secondary MUX card, the MPM puts the first DS0 channel of the T1 span trunk into loopback. While waiting to be initialized, the MUX card is continually transmitting a unique pattern over the reverse channel, and will detect when the pattern is received over the forward channel during  
15 loopback. Since the MUX card 119 only has read/write access on the first DS0 channel of the span trunk 128, this is the only channel that can be used for this initialization procedure. Also, if the concentrator has the aforementioned design nuance, a DS0 channel cannot be put into loopback more than once in a  
20 row without putting another channel into loopback first. So if necessary, the MPM puts the second DS0 channel of the T1 span trunk in and then out of loopback before starting the initialization procedure.

25 Once the first DS0 channel of the T1 span trunk is in loopback, the MPM sends a message indicating that secondary MUX card initialization is in progress, which is then broadcast to all secondary MUX cards by the primary MUX card. The MUX card that detects the pattern sends a successful response message to the MPM, and automatically performs a hard reset. Otherwise, if

the MPM times out waiting for a response, or a failure message is received, the MUX card remains uninitialized in the database. In either case, loopback is removed.

5 If the response was successful, the MUX card address in the message is compared to the T1 span trunk number. If they do not match, the span trunks are crossed and the initialization fails.

10 If the MUX card address is correct, the MPM waits for the reset to be completed, and then sends a polling configuration message to the primary MUX card containing the new station address. A timer is set to wait for an event from the MUX card. When the secondary MUX card is first polled, it immediately queues an event message for the RPU, indicating its ready status and any errors that may have occurred. If the event message is received and does not indicate any errors, the MUX card is marked as "ready" in the database. If the event message is not received or indicates errors, the MUX card remains uninitialized and the initialization is reattempted later.

20 As previously described, the call processing in the MPM is organized using state machines. Input tokens, which force a call processing function to be performed, consist of messages from the subscriber stations 141, the concentrator 113 and the CCUs 123, as well as timeouts. The tokens are broken into two categories: channel tokens from the CCUs, and RCC tokens from the concentrator and the subscriber stations. Timeout tokens are included in both categories, depending on which token type the MPM is waiting for when a timeout occurs. The

channel tokens and RCC tokens are used to index into one of two state machines, the channel state machine and RCC state machine respectively.

5 The MPM must determine the type of token received, and the identity of the subscriber station or channel that is affected by the token. The token type is used to determine whether the channel state transition table or the RCC state transition table is to be used. The MPM then looks up the action to be taken in the appropriate state transition table, using the token and the current state of the subscriber station or channel as input. The MPM processes the token by executing the function indicated by the table entry. The processing involves updating the necessary status in the database, generating the proper message responses and transitioning to the next  
10 RCC and/or channel state.  
15

The normal call processing logic flow is shown in Figure 6. The most common RCC and channel state combinations are listed, as well as the input token (T) and resulting action (A) required to transition from one state to another.

20 Initially, all subscriber stations 141 are in the RCC Idle state and all available channels are in the Channel Idle state, which indicates that no connections are set up or in progress.

25 The changes of state for a typical call termination are as follows. An Incoming Call message is received from the concentrator 113, which includes the Subscriber Index (SIDX) of the destination subscriber station. The SIDX is used by the concentrator to uniquely identify a subscriber, and is a func-

tion of the line group and line circuit initiating the call. This number is used to map to a subscriber station in the database. A Page message is sent out to the subscriber station having this SIDX, and the state of the subscriber station 141 is set to Page. When a Call Accept message is received from the subscriber station, a channel is assigned for this connection. The channel uniquely specifies a DS0 channel on a T1 span trunk 128, as well as a CCU/slot combination at the RRT 111. The concentrator 113 is commanded to assign the specified trunk to the subscriber station 141, and then initiates a preconnection test on the specified DS0 channel. The subscriber station 141 is set to the Ring Slot Test state, waiting for an acknowledgement from the concentrator 113. When the ACK message is received, the state of the subscriber station 141 is set to Active. At this point, the CCU 123 and the subscriber station 141 are informed of the channel assignment, and the channel is placed in the Ring Sync Wait state. When the CCU 123 indicates that synchronization has been acquired, the channel state is set to Sync Ring. Finally, when the CCU 123 indicates that the subscriber station 141 has gone offhook, the channel is set to the Sync Offhook state. The Sync Offhook state indicates that a voice connection is established.

A call origination begins with a Call Request message being received from the originating subscriber station 141. A channel is assigned for this connection, and the MPM commands the concentrator 113 to assign the specified trunk to the subscriber station 141. The subscriber station is set to the Offhook Slot Test state while waiting for the concentrator to

complete the preconnection test on the indicated DSO channel and respond with an acknowledgement. When the ACK message is received, the state of the subscriber station is set to Active. At this point, the CCU 123 and the subscriber station 141 are informed of the channel assignment. The channel state is set to Offhook Sync Wait until the channel gains synchronization. The base station CCU informs the MPM when it detects the transmission from the originating subscriber station 141. This causes the MPM to change the state of the channel to the Sync Offhook state, indicating that a voice connection is established.

When the MPM sets up a voice call, whether it is a terminating call or an originating call, the concentrator 113 must assign a trunk 128 to the appropriate line group and line circuit. Commanding a trunk assignment causes the concentrator 113 to initiate a preconnection test. From the concentrator perspective, a preconnection test involves sending a 55H pattern on the specified forward DSO channel, and checking for the 55H pattern on the reverse channel. If the pattern is received, the concentrator considers the preconnection test successful. At the CCU 123, each idle VCU is continually transmitting the preconnection pattern and also scans the incoming channel for the pattern. If a voice call is set up on that VCU within a certain window after the pattern is detected, the preconnection test is considered successful.

A normal disconnection begins when the subscriber station 141 goes onhook (an external phone going onhook is not detected). This causes the subscriber station to send a message indicating to the MPM that the call should be cleared. The MPM

informs the CCU 123 and the concentrator 113 that the call is being torn down, and the subscriber station and channel states are set to idle. In the case when a CCU detects a fade on the channel, the CCU sends a message indicating that synchronization is lost. This causes the MPM to set the subscriber station and channel states to Teardown and Disconnect respectively, until a message is received from the subscriber station or a time-outs counter expires indicating that the call should be cleared. Once this message is received, the channel and subscriber station states are placed back to idle, and the concentrator 113 and the CCU 123 are informed that the call has been torn down.

One of the RF channels between the channel modules 120 and the subscriber stations 141 is allocated as the RCC in accordance with a predetermined allocation routine.

After the first event is received from one of the CCU's indicating that it is ready, the MPM assigns that CCU as the CCU for the RCC. After an event is received acknowledging the assignment, the RCC is established and communication with the subscriber stations 141 can begin. The MPM will always attempt to establish the RCC on the channel corresponding to the BCC channel of the T1 span trunks 128 first, since this slot of the CCU cannot be used for voice calls.

There should be an RCC assigned whenever possible, since no voice calls can be established without this link to the subscriber stations. An RCC assignment is attempted when the following occurs: (1) a CCU completes initialization and there is no RCC; (2) the primary MUX card is recovered and there is no RCC; (3) the CCU that was assigned as the RCC goes down; (4) the

MUX card containing the CCU for the RCC goes down; (5) a channel response message is received from the CCU for the RCC indicating that the CCU is in a voice mode instead of a control mode; (6) the MPM times out waiting for the event acknowledging an RCC assignment; (7) the MPM times out waiting for an RCC message acknowledgement; (8) a CCU completes training and there is no RCC; or (9) the maintenance mode is disabled while a CCU is still in the configuration, and there is no RCC.

The MPM assigns an RCC only to a CCU that is already initialized, and the RCC can only be assigned on the first slot of the CCU. The MPM will always attempt to establish the RCC on the channel corresponding to the BCC channel first, since this slot of the CCU cannot be used for voice calls. If this slot is not available, the MPM steps through all CCUs in the configuration. If none of the CCUs have the first slot available, a voice call is torn down to allow for an RCC assignment.

Once a command is sent to assign a CCU as the RCC, an event is expected from that CCU indicating that the assignment was successful. If no event is received, the MPM will reassign the RCC elsewhere. Once the RCC is established, messages can be transmitted and received from the subscriber stations. There can be only one outstanding RCC message in the forward channel, and the MPM sends the next one only after an RCC Ack message is received. If an RCC Ack timeout occurs, the RCC is reassigned.

The concentrator/RPU interace unit 115 interfaces the concentrator with an Alcyon computer of the RPU 114. The interface unit 115 reconciles the differences between the voltage levels, rate, and protocols expected by these different systems.

The concentrator/RPU interface unit 115 handles the voltage conversion, rate conversion with the requisite data buffering and protocol interaction that is required to allow communication between the concentrator 113 and the RPU 114.

5            Figures 7A and 7B show the functions of the concentrator/RPU interface unit 115. In the signal path from the concentrator 113 to the RPU 114 (Figure 7A), the concentrator/RPU interface unit processes 64 kbps data through an AMI-to-TTL conversion unit 183, a serial-to-parallel converter 184, a  
10 byte comparator duplicate rejection unit 185, a 64 x 8 FIFO buffer 186, a UART 187 and a TTL-to-RS232 conversion unit 188. In the signal path from the RPU 114 to the concentrator 113 (Figure 7B), the concentrator/RPU interface unit 115 processes  
15 19.2 kbps data through an RS232-to-TTL conversion unit 190, a UART 191, a byte repeater duplicate insertion unit 192, a parallel-to-serial converter 193 and a TTL-to-AMI conversion unit 194.

The concentrator 113 communicates with the interface unit 115 over a synchronous 64 kbps bipolar DSO channel 135 in  
20 accordance with a protocol that requires the repetition of the last byte transmitted when the channel is idle. This guarantees constant activity over the bipolar channel, and helps keep the communication synchronous. The bipolar signal is alternate mark inverted (AMI), meaning that each one in the data string must  
25 send one pulse of opposite polarity to that transmitted by the previous one. Zeroes cause no activity on the line, so the signal is composed of positive, negative, and zero voltages (a ternary level signal).

The Alcyon computer of the RPU 114 communicates with the interface unit 115 over an asynchronous, 19.2 kbps RS232 link. This is the standard format used in computer communications, and involves a -12 volt idle channel with bursts of +12 volt bits to convey the bits of information. The RS232 format requires the insertion of start and stop bits to denote byte boundaries.

Since the two protocols require different rates of communication, the data from the higher rate, 64 kbps bipolar channel must be buffered down to the lower rate, 19.2 kbps RS232 link. The buffer 186 contains at least one entire message. The byte comparator duplicate rejection unit 185 detects and rejects the retransmitted bytes. This requires parallelization of the data by the serial-to-parallel converter 184 to enable detection of duplicates, and then reserialization by the UART 187 to transmit this data over the RS232 link.

The alternate mark inversion (AMI) signalling must be transformer coupled to properly isolate and terminate the channel from the Model 1218 concentrator. A pulse transformer is used to support data rates as low as 64 kbps, and the signal that is produced on the board is converted to TTL levels. The AMI signal is +/- 2 volts unterminated, and can be used to turn on transistors when one is being transmitted. This serial data must be parallelized using the byte boundary information contained in the AMI clock signal, and then duplicate bytes must be rejected. Original bytes must be buffered and transmitted over the RS232 link.

The RS232 protocol, including start and stop bits, is easily implemented by using an industry standard universal asynchronous receiver transmitter (UART) 187. The UART 187 is loaded with a byte to be sent, adds the start and stop bits and serializes the data. This TTL signal must be converted to RS232 voltages, and then the signal can be sent to the computer in the RPU 115.

The data flows in an identical fashion in the other direction, as shown in Figure 7B, with the exception that the UART 191 converts the data from serial to parallel, the data is not buffered from the low-rate to the high-rate, and the last byte sent is repeated by the byte repeater duplicate insertion unit 192 when there is no more information to be sent.

The interconnections between the concentrator 113, the interface unit 115 and the RPU 114 are shown in Figure 8.

The signals from the concentrator 113 are terminated in a punchblock 195, from which the lines 135 are connected to the interface unit 115. The clock lines 196, which are connected between the DSO/DP2 card of the concentrator and terminate on two wire-wrap pins on the backplane of the rack of the interface unit 114. These contain bipolar violations to signify byte boundaries, and must also be brought to the interface unit 115 to allow synchronization.

The Alcyon computer of the RPU 114 has a number of different channels that communicate over RS232 links.

There is a BCC protocol for providing the communications format for sending digital messages between the RPU 114, the MUX cards 119 and the CCUs 123.

BCC messages are variable length, and always contain addressing information and a command code. The RPU 114, CCUs 123 and MUX cards 119 can all generate messages as well as receive them. The messages are used for control purposes, for reporting status, and for handling call processing information.

BCC messages traffic occurs over several physical links, requiring two unique protocols. If a message path consists of more than one physical link, the appropriate protocol conversion is performed and the message is relayed to its destination.

The BCC protocol involves two physical transmission links, a BCC channel of a T1 span trunk 128 and the BCC bus 132.

The BCC bus 132 is an SDLC multi-drop line. The BCC bus 132 is used for communication between the MUX cards 119 and the CCUs 123. One of the MUX cards 119 is designated as the primary MUX card. All other MUX cards and all CCU's communicate with each other only via the primary MUX card.

A BCC message path can include either one or two hops over distinct physical links. If two hops are involved, the message is repackaged by converting the protocols as required, leaving the BCC message content intact.

The RPU 114 communicates directly with the primary MUX card via the BCC channel provided by a T1 span trunk 128. This message path involves only one physical link, and no protocol conversion is required.

The message path between the RPU 114 and the secondary MUX cards and the CCUs 123 involves two hops, and these messages are always intercepted by the primary MUX card. It is the task

of the primary MUX card to convert the protocol as required, while leaving the BCC message content unchanged.

5 The BCC Span link protocol describes the communications format for sending data between the RPU 114 and the primary MUX card. Both byte and message level synchronization are performed. The two types of characters transmitted over this link are control and data characters. All characters have the least significant bit set to satisfy the 1's density, and to ensure that the character is not interpreted as a link control character by the Model 1218 concentrator-switch in the concentrator 113.

10 The BCC Bus 132 protocol describes the communications format for sending data between the primary MUX card and the secondary MUX cards and the CCUs 123.

15 The serial protocol used is Synchronous Data Link Control (SDLC). With an SDLC protocol, the primary MUX card controls the overall BCC bus 132 and issues commands to the secondary MUX cards and the CCUs. The microcontroller 144 of the primary MUX card controls all of the MUX cards 119 on the BCC bus 132. The SIU of the microcontroller 144 is designed to perform serial communications with little or no CPU involvement. The SIU hardware supports the SDLC protocol and causes zero bit insertion/deletion. Address recognition, cyclic redundancy check (CRC), and frame number sequence checks are automatically performed.

25 The secondary MUX cards' SIUs operate in an Auto mode, where the SIU performs in hardware a subset of the SDLC protocol called the Normal Response Mode (NRM). The Auto mode enables

the SIU to recognize and respond to certain kinds of SDLC frames without intervention from the microcontroller's CPU. It also provides a faster turnaround time and a simplified software interface. In Auto mode, the microcontroller 144 can act only  
5 as a NRM secondary MUX card, meaning it can transmit only when instructed to do so by the primary MUX card. All such Auto mode responses adhere strictly to IBM's SDLC definitions.

In its Flexible mode, the microcontroller 144 can initiate transmissions without being polled, and thus it can act  
10 as the primary MUX card. The primary MUX card SIU is therefore operated in its Flexible (Non-Auto) mode. In the Flexible mode, reception and transmission of each frame by the SIU is performed under control of the CPU.

In both the Auto and Flexible modes, short frames, aborted frames, or frames which have bad CRC's are ignored by  
15 the SIU. The SDLC protocol is designed to limit the necessary buffering of messages to one in each direction, therefore limiting the number of outstanding messages (i.e., unacknowledged) to one in each direction of transmission.

The BCC bus message consists of the basic formatted  
20 SDLC frame.

Every MUX card 119 and CCU 123, including the primary MUX card, is assigned a unique station address. The primary MUX card uses the Station Address byte to determine the destination  
25 of the message. Each of the secondary MUX cards and the CCUs uses this byte in a response to identify itself as the secondary station that is transmitting.

Referring to Figure 9, the selection and assignment of a voice channel for a given subscriber station 141 is accomplished by the concentrator of RCC messages (i.e., data messages) between a Subscriber Control Task (SCT) software-implemented module 200 in the subscriber station 120 and the RPU 114 over the RCC.

The RCC protocol consists of two layers of protocol, a Data Link Layer 201 and a Packet Layer 202. The Data Link Layer 201 is responsible for word synchronization and framing, detection and resolution of collisions, and error detection. The Data Link Layer 201 consists of the Unique Word, Link Field, and Checksum Field. The Packet Layer 202 is responsible for addressing and call establishment information. The Packet Layer 202 consists of the Subscriber Identification, Command and Call Establishment Data.

The implementation of the RCC protocol is divided. The Packet Layer 202 is implemented in each subscriber station SCT module 200 and at the Base Station 204 in the RPU 114. The Data Link Layer 201 is implemented by the CCU 123 in the RCC channel module at the base station 204 and by a Channel Control Task (CCT) software-implemented module 205 at each subscriber station 141. The CCU 123 and the CCTs 205 are respectively connected to modems 206 and 207 for communicating with each other.

The Packet Layer 202 is used for call-establishment data and communicates information that is used to establish voice connections. Each packet contains one of several permis-

sible codes indicating the operation to be performed on the basis of the packet.

The Data Link Layer 201 provides for collision (conflicting contention for same time slot on same RF channel) resolution, timing between incoming and outgoing frames, and per-operation status information for use by higher-level error recovery procedures. The main purpose of the Data Link Layer is divided into two sublayers, (1) data encapsulation, which provides framing and error detection; and (2) link management, which provides channel allocation and collision resolution.

The CCU 123 and all CCTs 205 that are listening on the RCC must exhaustively check for a valid RCC message in every RCC slot. The CCT performs this task by scanning for the unique word in a window  $\pm 4$  symbols about the nominal UW location, based upon master system timing. The CCU listening on the RCC scans for the unique word in a window  $\pm 3$  symbols about the nominal UW location. The search algorithm shifts the data until it finds the UW pattern, or until all possibilities have been exhausted. Once the UW pattern is found, the RCC message is considered valid only if the RCC checksum is correct. At the base station 204, the shift information, RCC message and power information are sent to the RPU 114 following a successful search. The subscriber station 141 uses the shift information to align its receive clock with the base station's master clock. Subsequent RCC messages are then transferred to the SCT 200 for processing.

When a subscriber station 141 attempts to transmit on the reverse control channel after a power-up or reset operation or after a long period of listen only operation, it must quickly

and accurately determine the correct transmit power level. Ranging and atmospheric effects may make initial communication with the base station 204 impossible until the subscriber station's transmit power is adjusted to be within a required gain window. The power level determination must also ensure that the subscriber station 141 does not transmit with too much power since its transmissions can interfere with the transmissions of other subscribers.

To facilitate this initial adjustment, the base station CCU 123 feeds back a coarse measure of reverse channel RCC power in every forward channel RCC burst. Each reverse channel burst received by the base station 204 shall have its respective AGC level quantized into one of four values. The quantized level is transmitted in the forward channel burst immediately following channel reception. Two bits in RCC link byte #1 are reserved for this purpose. The power information is transmitted independent of whether or not the reverse channel burst is successfully decoded. The power level value is also totally independent of the actual content of the forward channel RCC burst.

The power level information is not used if the subscriber station 141 receives a valid RCC acknowledgement from the base station CCU 123 following reverse channel RCC transmission. Power and timing information fed back later, as part of the RPU 114 reply, is used to make the proper adjustment.

If the subscriber station 141 does not receive a positive RCC acknowledgement from the base station CCU 123 as expected, the power feedback value is used to determine a local transmit power adjustment.

A subscriber station 141 detects a collision by monitoring the RCC message in the forward channel after having transmitted in the previous frame on the reverse channel. If the subscriber station determines that a collision has occurred, the subscriber station performs the collision backoff algorithm. The same station CCU 123 acknowledges a transmission by echoing the received RCC message back over the forward channel, setting the Burst Type bits in RCC link byte #1 to RCC Acknowledge to flag the message as an ACK.

When a transmission attempt has terminated due to a collision, it is retried by the subscriber station 141 until it is successful, or four attempts (the original attempt plus three retries) have been made and all have been terminated due to collisions. Note that all attempts to transmit a given frame are completed before any subsequent frames are transmitted. The scheduling of the retransmission is determined by a controlled randomization process. When a subscriber station 141 detects a collision, it delays an integral number of slot times before attempting to retransmit. If all four attempts fail, then an error is reported.

A CCITT Cyclic Redundancy Check (CRC) is used to detect errors that occur during the transmission of the RCC messages. The CRC algorithm involves the division of a block of data by a predefined bit sequence and the transmission of a remainder of that division as a part of the data block. The polynomial to generate the 16-bit CCITT CRC is of the form:

$$P(x) = 1 + x^5 + x^{12} + x^{16} \quad (\text{Eq. 1})$$

The RPU 114 causes connections between a given external communication network port and a given subscriber station 141 to be completed over a time slot assigned in response to the monitored status in accordance with a predetermined assignment routine. The CCU's 123 are coupled to the MUX cards 119 for coupling assigned time slots to given subscriber stations, with each CCU 123 coupling a plurality of assigned time slots to a corresponding plurality of subscriber stations 141.

10 The predetermined assignment routine includes assigning all of the time slots associated with a given CCU 123 before assigning time slots associated with another active CCU 123, and then assigning time slots associated with a CCU 123 coupled to a different MUX card 119 than the MUX card coupled to the CCU 123 associated with the immediately previously assigned time slots. In accordance with this predetermined assignment routine, the selection criteria are to conserve power by limiting the number of power amplifiers 121 that are in use, to spread the communication assignments among the different T1 trunks 128, and to avoid the first time slot of the T1 trunks, since it is desired to reserve the first time slot of the T1 trunks for use as a back-up BCC link should the primary BCC link become inoperative.

25 When a time slot assignment requirement arises, first there is a search for a vacant time slot in an already active RF channel. All T1 spans are scanned, beginning with the T1 trunk coupled to the MUX card coupled to the CCU for which the last RF channel was allocated. When there are no vacant time slots in any of the already active RF channels coupled to the T1 span

that is being scanned, then the search proceeds to a different T1 span. When there are no vacant time slots in any of the already active RF channels coupled to any of the different T1 spans, then a search is made for an unused RF channel coupled by a CCU and a MUX card to a T1 trunk for a T1 span other than the T1 span coupled to the CCU for which the last RF channel was activated. If there are no vacant time slots for an unused RF channel coupled to any of the other T1 spans, then the search for an unused RF channel proceeds to the T1 span coupled to the CCU for which the last time slot was activated.

Referring to Fig. 4 the echo canceller units 116 cancel echoes in voice signals communicated over the trunk. The RPU 114 is coupled to the echo cancellers 116 by line 210 for enabling the operation of the echo cancellers 116 during only those time slots that have been assigned by the RPU to carry voice signals.

## CLAIMS

1. A base station in a subscriber communication network for communicating between subscriber stations and an external network comprising

a communication circuit in communication with a plurality of subscriber stations via a predetermined communication channel having multiple sequentially repetitive time slots, each time slot being assigned to a corresponding subscriber station;

a remote-connection processor in communication with said communication circuit and with an exchange for directing communications between said communication circuit and said exchange;

said exchange being in communication with said external communication network;

said remote-connection processor comprising a remote concentrator and said exchange comprising a central concentrator, said concentrators being in communication with each other via bit streams generated and received by each, bit streams transmitted by said central concentrator to said remote concentrator containing signals initiated by said external network and bit streams transmitted by said remote concentrator to said central concentrator containing signals initiated by said subscriber stations, said bit streams containing multiple sequentially repetitive time slots; and

a separate, non-varying control channel for transmitting only control signals initiated by said subscriber stations.

2. The base station of Claim 1 wherein said remote concentrator is provided with a plurality of ports and a buffer is

connected to said ports by corresponding line pairs, said buffer acting to interface said remote concentrator with said communication circuit for directing signals between time slots in said communication channel and corresponding ports in said remote concentrator.

3. A base station according to Claim 1, characterized by the exchange being remotely located from the communication circuit and the remote-connection processor.

4. A base station according to Claim 3, characterized by means for transmitting the bit stream between the exchange and the communication circuit by microwave.

5. A base station in a subscriber communication network for communicating signals between subscriber stations and an external communication network having a plurality of ports, comprising

a communication circuit including  
a trunk for providing a communication channel and  
a multiplexer coupled to the trunk for providing multiple sequentially repetitive time slots in the communication channel for enabling simultaneous communications between a plurality of the ports and a plurality of the subscriber stations over the communication channel;

an exchange for connecting the trunk to the external communication network ports; and

a remote-connection processor coupled to the trunk in the communication circuit by a base-station control channel and to the exchange for monitoring the status of the time slots and for causing the communication circuit and the exchange to complete a connection between a given external communication network port and a given subscriber station over a time slot assigned in response to said monitored status in accordance with a predetermined assignment routine;

wherein the communication circuit further comprises

a plurality of channel control units coupled to the multiplexer for coupling assigned time slots to given subscriber stations; and

15 a plurality of communication signal processors coupled to given subscriber stations by the channel control units in response to command signals from the remote-connection processor, wherein the communication signal processors are respectively coupled by the multiplexer to predetermined time slots of  
20 the communication channel carried over the trunk, and each communication signal processor provides a predetermined signal pattern in its predetermined time slot when not coupled by its channel control unit to the remote-connection processor;

25 wherein the exchange is responsive to a command from the remote-connection processor causing a signal received by the exchange from one of the communication signal processors over a given time slot to be looped back to the communication signal processor coupled to that time slot; and

wherein each communication signal processor is coupled to one of the channel control units for enabling the coupled channel control unit in response to a said looped-back predetermined signal pattern to receive commands from the remote-connection processor for assigning the communication signal processor that receives the looped-back predetermined signal pattern to communicate with a given subscriber station.

6. A base station according to claim 6,

wherein the remote-connection processor comprises means for assigning a given time slot to a given subscriber station, said assigning means including

means for commanding the exchange to loop back signals received from the communication signal processor coupled to the given time slot;

means for sending an address initialization signal over the base-station control channel to all of the channel control units to store an address associated with the given subscriber station in the channel control unit that is enabled in response to the communication signal processor coupled thereto receiving said looped-back predetermined signal pattern; and

means for commanding the channel control unit in which the address is stored to assign the given-time-slot-coupled communication signal processor to the given subscriber station.

7. A base station according to claim 7,

wherein each channel control unit includes means for responding to storage of said address by sending an acknowledgement to the remote-connection processor; and

wherein the remote-connection processor further includes means for commanding the exchange to loop back signals received from the communication signal processor coupled to a different given time slot when no acknowledgement is received from the channel control unit coupled to the communication signal processor coupled to the first-recited given time slot.

8. A base station in a subscriber communication network for communicating signals between subscriber stations and an external communication network having a plurality of ports, comprising

a communication circuit including

a trunk for providing a communication channel; and

a multiplexer coupled to the trunk for providing multiple sequentially repetitive time slots in the communication channel for enabling simultaneous communications between a plurality of the ports and a plurality of the subscriber stations over the communication channel;

an exchange for connecting the trunk to the external communication network ports; and

a remote-connection processor coupled to the communication circuit by a base-station control channel which occupies one of the time slots, and to the exchange for monitoring the status of the time slots and for causing the communication circuit and the exchange to complete a connection between a given external communication network port and a given subscriber station over a time slot assigned in response to said monitored status in accordance with a predetermined assignment routine;

wherein the communication circuit further comprises

a plurality of channel control units coupled to the multiplexer for coupling assigned time slots to given subscriber stations; and

5 wherein one of the channel control units communicates control signals between the base-station control channel and all of the subscriber stations over a radio control channel allocated to a given time slot of a given frequency channel by the remote-connection processor in response to said monitored status in accordance with a predetermined allocation routine in which  
10 the first priority is given to the time slot of the radio frequency channel that is coincident with the time slot occupied by the base-station control channel.

9. A base station in a subscriber communication network for communicating signals between subscriber stations  
15 and an external communication network having a plurality of ports, comprising

a communication circuit including

a plurality of trunks for providing a plurality of communication channels; and

20 a plurality of multiplexers coupled to the plurality of trunks for providing multiple sequentially repetitive time slots in each of the communication channels for enabling simultaneous communications between a plurality of the ports and a plurality of the subscriber stations over the communication  
25 channels;

an exchange for connecting the trunks to the external communication network ports; and

a remote-connection processor coupled to the communi-

cation circuit by a base-station control channel which occupies one of the time slots, and to the exchange for monitoring the status of the time slots and for causing the communication circuit and the exchange to complete a connection between a given external communication network port and a given subscriber station over a time slot assigned in response to said monitored status in accordance with a predetermined assignment routine;

wherein the communication circuit further comprises

a plurality of channel control units coupled to the multiplexers for coupling assigned time slots to given subscriber stations;

a plurality of controllers respectively coupled to the multiplexers; and

a local bus between the controllers and the channel control units;

wherein, in accordance with said monitored status, the remote-connection processor selects one of the time slots to carry the base-station control channel and causes the controller that is coupled to the multiplexer that is coupled to the trunk that carries the time slot selected to carry the base-station control channel to function as a primary controller for coupling the base-station control channel over the local bus to the other controllers and to the channel control units for enabling the remote-connection processor to monitor the status of the other time slots and to assign the other time slots.

10. A base station according to claim 10,

wherein the communication circuit includes a plurality of communication signal processors coupled to given subscriber

stations by the channel control units in response to command signals from the remote-connection processor, wherein the communication signal processors are respectively coupled by the multiplexers to predetermined time slots of predetermined communication channels carried over the trunks, and each communication signal processor provides a predetermined signal pattern in its predetermined time slot when not coupled by its channel control unit to the remote-connection processor;

wherein the exchange is responsive to a command from the remote-connection processor for causing a signal received by the exchange from one of the communication signal processors over a given time slot to be looped back to the communication signal processor coupled to that time slot; and

wherein each communication signal processor is coupled to one of the channel control units for enabling the coupled channel control unit in response to a said looped-back predetermined signal pattern to receive commands from the remote-connection processor for assigning the communication signal processor that receives the looped-back predetermined signal pattern to communicate with a given subscriber station.

11. A base station according to claim 11,

wherein the remote-connection processor comprises means for assigning a given time slot to a given subscriber station, said assigning means including

means for commanding the exchange to loop back signals received from the communication signal processor coupled to the given time slot;

means for sending an address initialization signal  
over the base-station control channel to all of the channel  
control units to store an address associated with the given  
subscriber station in the channel control unit that is enabled  
5 in response to the communication signal processor coupled  
thereto receiving said looped-back predetermined signal pattern;  
and

means for commanding the channel control unit in which  
the address is stored to assign the given-time-slot-coupled  
10 communication signal processor to the given subscriber station.

12. A base station according to claim 12,

wherein each channel control unit includes means for  
responding to storage of a said address by sending an  
acknowledgement to the remote-connection processor; and

15 wherein the remote-connection processor further  
includes means for commanding the exchange to loop back signals  
received from the communication signal processor coupled to a  
different given time slot when no acknowledgement is received  
from the channel control unit coupled to the communication  
20 signal processor coupled to the first-recited given time slot.

13. A base station according to claim 10, wherein one  
of the channel control units communicates control signals  
between the base-station control channel and all of the  
subscriber stations over a radio control channel allocated to a  
25 given time slot of a given frequency channel by the remote-  
connection processor in response to said monitored status in  
accordance with a predetermined allocation routine in which the  
first priority is given to the time slot of the radio frequency

channel that is coincident with the time slot occupied by the base-station control channel.

14. A base station according to claim 10, wherein the multiplexers and the channel control units are modular for enabling their addition to and removal from the system in accordance with changes in the number of subscriber stations with which the base station communicates.

15. A base station in a subscriber communication network for communicating signals between subscriber stations and an external communication network having a plurality of ports, comprising

a communication circuit including

a plurality of trunks for providing a plurality of communication channels; and

a plurality of multiplexers coupled to the plurality of trunks for providing multiple sequentially repetitive time slots in each of the communication channels for enabling simultaneous communications between a plurality of the ports and a plurality of the subscriber stations over the communication channels;

an exchange for connecting the trunks to the external communication network ports; and

a remote-connection processor coupled to the trunks in the communication circuit by a base-station control channel and to the exchange for monitoring the status of the time slots and for causing the communication circuit and the exchange to complete a connection between a given external communication network port and a given subscriber station over a time slot assigned in response to said monitored status in accordance with a predetermined assignment routine;

wherein the communication circuit further comprises  
a plurality of channel control units coupled to the  
multiplexers for coupling assigned time slots to given sub-  
5 subscriber stations, with each channel control unit coupling a  
plurality of assigned time slots to a corresponding plurality of  
subscriber stations;

wherein said assignment routine includes assigning all  
of the time slots associated with a given channel control unit  
10 before assigning time slots associated with another channel  
control unit, and then assigning time slots associated with a  
channel control unit coupled to a different multiplexer than the  
multiplexer coupled to the channel control unit associated with  
the immediately previously assigned time slots.

15 16. A base station in a subscriber communication  
network for communicating signals between subscriber stations  
and an external communication network having a plurality of  
ports, comprising

a communication circuit including  
20 a trunk for providing a communication channel; and  
a multiplexer coupled to the trunk for providing multi-  
ple sequentially repetitive time slots in the communication  
channel for enabling simultaneous communications of digital  
information signals between a plurality of the ports and a plu-  
25 rality of the subscriber stations over the communication  
channel;

an exchange for connecting the trunk to the external  
communication network ports; and

a remote-connecting processor coupled to the trunk in the communication circuit by a base-station control channel and to the exchange for monitoring the status of the time slots and for causing the communication circuit and the exchange to complete a connection between a given external communication network port and a given subscriber station over a time slot assigned in response to said monitored status in accordance with a predetermined assignment routine;

10            wherein the communication circuit further comprises  
             a plurality of channel control units coupled to the multiplexer for coupling assigned time slots to given subscriber stations via radio frequency channels; and

15            a plurality of channel control units coupled to given subscriber stations by the channel control units in response to command signals from the remote-connection processor, wherein the communication signal processors are respectively coupled by the multiplexer to predetermined time slots of the communication channel carried over the trunk and by the channel control units to given time slots of the radio frequency channels.

20            17. A base station according the claim 17,  
             wherein the exchange comprises a concentrator.

             18. A base station according to claim 17,  
             wherein means are provided to decrease jitter and to control slips in the received signals, said means comprising a  
25            frame buffer containing a plurality of frames

             wherein a selected address within each frame corresponds to a selected channel assignment, said frames having an initial predetermined separation.

19. A base station according to claim 17 further comprising

an echo canceller for cancelling echoes in voice signals communicated over the trunk;

5 wherein the remote-connection processor is coupled to the echo canceller for enabling the operation of the echo canceller during only those time slots that have been assigned by the remote-connection processor to carry voice signals.

---

REGISTER ENTRY FOR GB2208774

Form 1 Application No GB8806221.1 filing date 16.03.1988

Priority claimed:

14.08.1987 in United States of America - doc: 071279

Title BASE STATION FOR WIRELESS DIGITAL TELEPHONE SYSTEM

Applicant/Proprietor

INTERNATIONAL MOBILE MACHINES CORPORATION, Incorporated in USA -  
Pennsylvania, 100 North 20th Street, Philadelphia, Pennsylvania 19103,  
United States of America [ADP No. 00520486001]

Inventors

GRAHAM M AVIS, 4330 Huerfano Avenue, San Diego, California 92117, United  
States of America [ADP No. 00093781001]

TERRENCE STEPHEN COLLINS, 2884 Mt Abraham Avenue, San Diego, California  
92111, United States of America [ADP No. 03986759001]

MARTIN KEITH SCHROEDER, 8191 Valdosta Avenue, San Diego, California 92126,  
United States of America [ADP No. 03986767001]

BRIAN GREGORY KIERNAN, 31 Redstone Ridge, Voorhees, New Jersey 08043,  
United States of America [ADP No. 03986775001]

JONATHAN WILLIS MECHLING, 304J Forbes Street, Annapolis, Maryland 21401,  
United States of America [ADP No. 03986791001]

THOMAS E FLETCHER, 3474 Stellar Drive, San Diego, California 92123, United  
States of America [ADP No. 03986817001]

WENDELIN R AVIS, 4330 Huerfano Avenue, San Diego, California 92117,  
United States of America [ADP No. 03986825001]

GREGORY T SAFFEE, 10333 Orozco Road, San Diego, California 92124, United  
States of America [ADP No. 03986841001]

KARLE JOSEPH JOHNSON, 6428 Chiriqui Lane, Carlsbad, California 92009,  
United States of America [ADP No. 03986866001]

Classified to

H4K  
H04Q

Address for Service

CARPMAELS & RANSFORD, 43 Bloomsbury Square, LONDON, WC1A 2RA, United  
Kingdom [ADP No. 00000083001]

Publication No GB2208774 dated 12.04.1989

Examination requested 26.04.1989

Patent Granted with effect from 31.07.1991 (Section 25(1)) with title BASE  
STATION FOR WIRELESS DIGITAL TELEPHONE SYSTEM

---

- 05.01.1994 Application under Section 32 filed on 23.12.1993  
Entry Type 8.1 Staff ID. NM Auth ID. F20
- 10.01.1994 Application under Section 32 filed on 23.12.1993  
Entry Type 8.1 Staff ID. NM Auth ID. F21
- 10.01.1994 Notification of change of Applicant/Proprietor name and address of  
INTERNATIONAL MOBILE MACHINES CORPORATION, Incorporated in USA -  
Pennsylvania, 100 North 20th Street, Philadelphia, Pennsylvania  
19103, United States of America [ADP No. 00520486001]  
to  
INTERDIGITAL COMMUNICATIONS CORPORATION, Incorporated in USA -  
Pennsylvania, 2200 Renaissance Boulevard, Suite 105, KING OF  
PRUSSIA, PA 19406, United States of America [ADP No. 06469985001]  
dated 27.04.1993. Official evidence filed on GB2240690  
Entry Type 7.1 Staff ID. SA Auth ID. F20
- 10.01.1994 INTERDIGITAL TECHNOLOGY CORPORATION, Incorporated in USA -  
Delaware, 900 Market Street, 2nd Floor, Wilmington, Delaware 19801,  
United States of America [ADP No. 06366348001]  
registered as Applicant/Proprietor in place of  
INTERDIGITAL COMMUNICATIONS CORPORATION, Incorporated in USA -  
Pennsylvania, 2200 Renaissance Boulevard, Suite 105, KING OF  
PRUSSIA, PA 19406, United States of America [ADP No. 06469985001]  
by virtue of deed of assignment dated 30.11.1993. Certified copy  
filed on GB2240690  
Entry Type 8.4 Staff ID. SA Auth ID. F21

\*\*\*\* END OF REGISTER ENTRY \*\*\*\*

DA80-01  
FG

OPTICS - PATENTS

07/04/94 10:50:30  
PAGE: 1

RENEWAL DETAILS

PUBLICATION NUMBER GB2208774

PROPRIETOR(S)

Interdigital Technology Corporation, Incorporated in USA - Delaware,  
900 Market Street, 2nd Floor, Wilmington, Delaware 19801, United  
States of America

DATE FILED	16.03.1988
DATE GRANTED	31.07.1991
DATE NEXT RENEWAL DUE	16.03.1994
DATE NOT IN FORCE	
DATE OF LAST RENEWAL	08.03.1993
YEAR OF LAST RENEWAL	06
STATUS	PATENT IN FORCE