



(12) **DEMANDE DE BREVET CANADIEN  
CANADIAN PATENT APPLICATION**

(13) **A1**

(86) Date de dépôt PCT/PCT Filing Date: 2019/06/26  
(87) Date publication PCT/PCT Publication Date: 2020/03/26  
(85) Entrée phase nationale/National Entry: 2021/03/17  
(86) N° demande PCT/PCT Application No.: CA 2019/000097  
(87) N° publication PCT/PCT Publication No.: 2020/056484  
(30) Priorités/Priorities: 2018/09/17 (US62/732,240);  
2019/02/13 (CA PCT/CA2019/000019)

(51) Cl.Int./Int.Cl. *G02B 3/06* (2006.01),  
*F41H 3/00* (2006.01), *G02B 1/11* (2015.01),  
*G02B 5/18* (2006.01), *G03B 21/602* (2014.01),  
*G03B 21/604* (2014.01), *H04N 13/363* (2018.01)  
(71) Demandeur/Applicant:  
HYPERSTEALTH BIOTECHNOLOGY CORPORATION,  
CA  
(72) Inventeur/Inventor:  
CRAMER, GUY, CA  
(74) Agent: MCMILLAN LLP

(54) Titre : SYSTEME ET PROCEDES DE DIFFUSION, DE DEVIATION ET DE MANIPULATION LASER  
(54) Title: SYSTEM AND METHODS FOR LASER SCATTERING, DEVIATION AND MANIPULATION

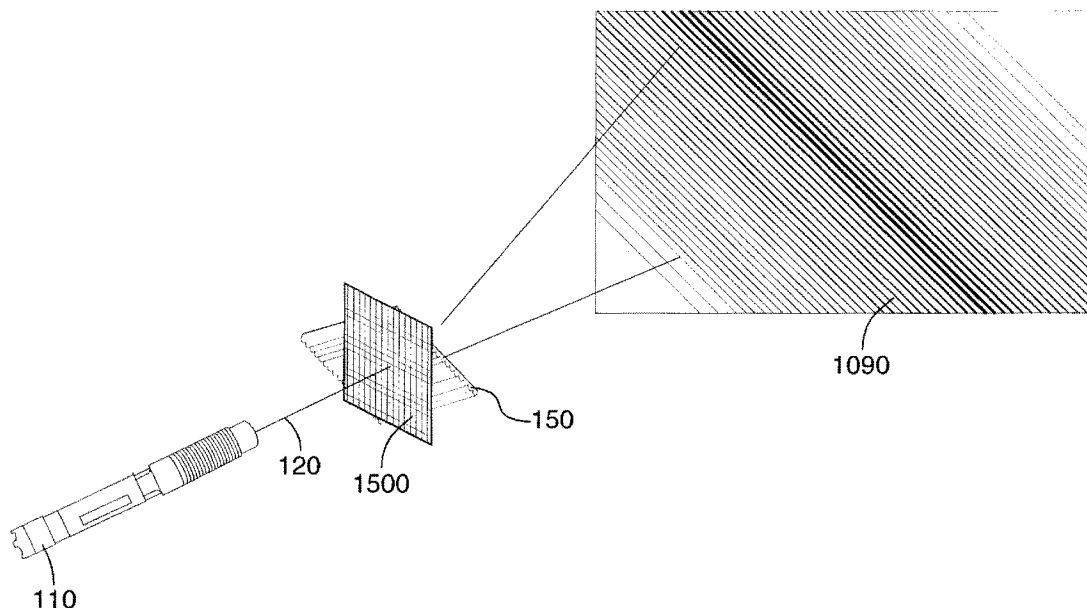

FIG. 20

(57) **Abrégé/Abstract:**

Systems and methods for scattering or deviating a laser beam are provided. A system utilizing a lenticular sheet and a laser source projecting a laser beam onto the lenticular sheet produces shapes such as laser cones. Minor adjustments of the laser source with respect to the lenticular sheet may vary the size and shape of the laser cone that provides for improved Light Detection and Ranging (LIDAR) systems. A diffraction grating added in the path of the laser beam causes a laser pattern of a matrix of lines to be produced which also provides for improved. Interference between multiple lenticular sheets may be used to deviate a laser beam to protect military assets from laser-guided projectiles and/or laser acquisition.'

## (12) INTERNATIONAL APPLICATION PUBLISHED UNDER THE PATENT COOPERATION TREATY (PCT)

(19) World Intellectual Property  
Organization  
International Bureau

(43) International Publication Date  
26 March 2020 (26.03.2020)



(10) International Publication Number  
**WO 2020/056484 A1**

## (51) International Patent Classification:

*G02B 3/06* (2006.01)      *G03B 21/602* (2014.01)  
*F41H 3/00* (2006.01)      *G03B 21/604* (2014.01)  
*G02B 1/11* (2015.01)      *H04N 13/363* (2018.01)  
*G02B 5/18* (2006.01)

## (21) International Application Number:

PCT/CA2019/000097

## (22) International Filing Date:

26 June 2019 (26.06.2019)

## (25) Filing Language:

English

## (26) Publication Language:

English

## (30) Priority Data:

62/732,240      17 September 2018 (17.09.2018)      US  
PCT/CA2019/000019  
13 February 2019 (13.02.2019)      CA

(71) Applicant: **HYPERSTEALTH BIOTECHNOLOGY CORPORATION** [CA/CA]; 20,000 Stewart Crescent, Unit #3, Maple Ridge, British Columbia V2X 9E7 (CA).

(72) Inventor: **CRAMER, Guy**; 20,000 Stewart Crescent, Unit #3, Maple Ridge, British Columbia V2X 9E7 (CA).

(74) Agent: **BIRD, Keith**; McMillan LLP, Brookfield Place, 181 Bay Street, Suite 4400, Toronto, Ontario M5J 2T3 (CA).

(81) Designated States (*unless otherwise indicated, for every kind of national protection available*): AE, AG, AL, AM, AO, AT, AU, AZ, BA, BB, BG, BH, BN, BR, BW, BY, BZ, CA, CH, CL, CN, CO, CR, CU, CZ, DE, DJ, DK, DM, DO, DZ, EC, EE, EG, ES, FI, GB, GD, GE, GH, GM, GT, HN, HR, HU, ID, IL, IN, IR, IS, JO, JP, KE, KG, KH, KN, KP, KR, KW, KZ, LA, LC, LK, LR, LS, LU, LY, MA, MD, ME, MG, MK, MN, MW, MX, MY, MZ, NA, NG, NI, NO, NZ, OM, PA, PE, PG, PH, PL, PT, QA, RO, RS, RU, RW, SA,

## (54) Title: SYSTEM AND METHODS FOR LASER SCATTERING, DEVIATION AND MANIPULATION

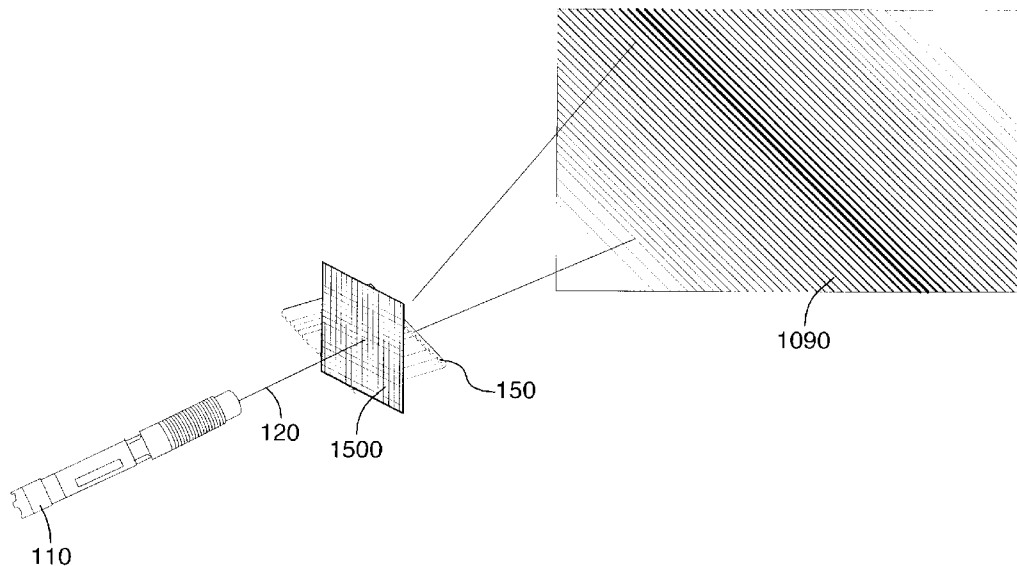

FIG. 20

(57) Abstract: Systems and methods for scattering or deviating a laser beam are provided. A system utilizing a lenticular sheet and a laser source projecting a laser beam onto the lenticular sheet produces shapes such as laser cones. Minor adjustments of the laser source with respect to the lenticular sheet may vary the size and shape of the laser cone that provides for improved Light Detection and Ranging (LIDAR) systems. A diffraction grating added in the path of the laser beam causes a laser pattern of a matrix of lines to be produced which also provides for improved. Interference between multiple lenticular sheets may be used to deviate a laser beam to protect military assets from laser-guided projectiles and/or laser acquisition.<sup>1</sup>

**WO 2020/056484 A1** 

SC, SD, SE, SG, SK, SL, SM, ST, SV, SY, TH, TJ, TM, TN,  
TR, TT, TZ, UA, UG, US, UZ, VC, VN, ZA, ZM, ZW.

- (84) Designated States** (*unless otherwise indicated, for every kind of regional protection available*): ARIPO (BW, GH, GM, KE, LR, LS, MW, MZ, NA, RW, SD, SL, ST, SZ, TZ, UG, ZM, ZW), Eurasian (AM, AZ, BY, KG, KZ, RU, TJ, TM), European (AL, AT, BE, BG, CH, CY, CZ, DE, DK, EE, ES, FI, FR, GB, GR, HR, HU, IE, IS, IT, LT, LU, LV, MC, MK, MT, NL, NO, PL, PT, RO, RS, SE, SI, SK, SM, TR), OAPI (BF, BJ, CF, CG, CI, CM, GA, GN, GQ, GW, KM, ML, MR, NE, SN, TD, TG).

**Published:**

- *with international search report (Art. 21(3))*

**SYSTEM AND METHODS FOR LASER  
SCATTERING, DEVIATION AND MANIPULATION**

**Field of the Invention**

5 [0001] The present invention relates generally to manipulation of light rays, and more specifically to a system and methods for laser scattering, deviation, and manipulation.

**Background of the Invention**

10 [0002] Laser stands for "light amplification by stimulated emission of radiation". A laser differs from other sources of light in that it emits light coherently, both spatially and temporally. Spatial coherence allows a laser to be focused to a tight spot, enabling applications such as laser cutting and lithography. Spatial coherence also allows a laser beam to stay narrow over great distances (collimation), enabling applications such as laser pointers. Lasers can also have high temporal coherence, which allows them to emit light with a very narrow spectrum, i.e., they can emit a single color of light. Temporal coherence can be used to produce pulses of light as short as a femtosecond.

15 [0003] A lenticular sheet is a translucent plastic sheet, made by distinctive and precise extrusion with a series of vertically aligned, plano-convex, cylindrical lenses called lenticules on one side and a flat surface on the other side. The lenticules help transform a 2D image into a variety of visual illusions wherein a viewer may see lenticular special effects when the orientation of a lenticular sheet is changed. A lenticular sheet may be made  
20 from acrylic, APET, PETG, polycarbonate, polypropylene, PVC or polystyrene. Each of those different materials has a different level of sensitivity to temperature and UV light.

[0004] An important characteristic of a lenticular sheet is the density of lenses. The density of lenses is expressed as a lens-per-inch or lenticules-per-inch (LPI). The thickness of a lenticular sheet is usually but not always reversely correlated to the LPI; the lower the  
25 LPI the thicker the lenticular sheet is. Another important characteristic of a lenticular sheet

is the viewing angle. The viewing angle of a lenticular sheet is a v-shaped region within which lenticular images may be viewed clearly.

**[0005]** A diffraction grating is a plate of glass, plastic or metal ruled with very close parallel lines, producing a spectrum by diffraction and interference of light. A diffraction grating is an optical component with a periodic structure that splits and diffracts light into several beams travelling in different directions. The emerging coloration is a form of structural coloration. The directions of the beams depend on the spacing of the grating and the wavelength of the light so that the grating acts as the dispersive element. Holographic diffraction gratings are highly efficient embossed Holographic Optical Elements (HOE). Diffraction gratings are used for the direct viewing and analysis of spectra from different gas tubes and other light sources. The pattern size, measured in number of lines per inch or lines per mm (millimeter), is an important characteristic of a diffraction grating. Some diffraction gratings have 13,500 lines per inch. A single axis diffraction grating has a plurality of parallel lines. A double axis diffraction grating has a first plurality of parallel lines and a second plurality of parallel lines perpendicular to the first plurality of parallel lines. Diffraction gratings are used in experiments pertaining to the study of light and color.

**[0006]** LiDAR (Light Detection And Ranging) is a laser-based remote sensing technology. The theory behind LiDAR is to point a laser beam at a surface and measure the time it takes the laser to strike an object. An optical sensor typically at or near the laser source detects these strikes. Then knowing that laser travels at the speed of light, the distance to the detected surface can be determined by multiplying the speed of light by the detection time and then dividing by two. A LIDAR system thus utilizes at least one laser source and at least one sensor. A LiDAR system may be ground-based, water-based, space-based or mounted on an airplane, a car, or a UAV (unmanned aerial vehicle).

## Summary

[0007] In one aspect of the present disclosure, there is provided a system for diverting a laser beam. The system comprises a laser source emitting an incident laser beam comprising a plurality of rays projecting as a dot, and a lenticular sheet having a lens side  
5 comprising a plurality of parallel longitudinal lenticular lenses and a smooth side opposite the lens side. The laser source is aimed towards the lens side of the lenticular sheet such that the incident laser beam falls onto at least one of the plurality of parallel longitudinal lenticular lenses. A first portion of the plurality of rays of the incident laser beam is diverted by refraction to form a refracted beam of a first shape. A second portion of the plurality of  
10 rays of the incident laser beam is reflected by a surface of the at least one of the plurality of parallel longitudinal lenticular lenses to form a reflected beam of a second particular shape.

[0008] In one embodiment, the laser source is aimed so that the first incident laser beam falls perpendicularly onto the at least one of the plurality of parallel longitudinal lenticular lenses, the first portion of the incident the laser beam diverted by refraction represents a  
15 majority of the plurality of rays of the incident laser beam, and the refracted beam of the first particular shape is in the form of a triangular plane beam projected as a straight line.

[0009] In one embodiment, the lenticular sheet is placed in an upright position such that the plurality of parallel longitudinal lenses are oriented horizontally, the triangular plane beam is vertically oriented, and the projected straight line is vertical.

20 [0010] In one embodiment, the lenticular sheet is placed in an upright position such that the plurality of parallel longitudinal lenticular lenses are oriented vertically, the triangular plane beam is horizontally oriented, and the projected straight line is horizontal.

[0011] In one embodiment, the laser source is aimed so that the incident laser beam falls at an angle of incidence to a perpendicular direction onto the at least one of the plurality of  
25 parallel longitudinal lenticular lenses such that the first portion of the plurality of rays of the

first incident laser beam diverted by refraction represents a majority of the plurality of rays of the first incident laser beam, the first incident laser beam is in the same plane as a horizontal plane passing through the at least one of the plurality of parallel longitudinal lenticular lenses, and the refracted beam of a particular shape is in the form of a curved plane projected as an arc.

5 [0012] In one embodiment, the laser source is aimed so that the first incident laser beam falls at an incident angle off of a perpendicular direction onto the at least one of the plurality of parallel longitudinal lenticular lenses such that the first and second portions together form a cone projecting to a circle.

10 [0013] In one embodiment, the lens side of the lenticular sheet is coated with reflective material such that the second portion of the plurality of rays reflected by the surface of the at least one of the plurality of longitudinal lenticular lenses comprises all of the plurality of rays of the incident laser beam.

15 [0014] In one embodiment, an anti-reflective layer or coating is disposed on at least one of the lens side and the smooth side of the lenticular sheet for reducing the second portion of the plurality of rays of the incident laser beam which is reflected by the surface of the at least one of the plurality of longitudinal lenticular lenses.

20 [0015] In one embodiment, the system further comprises at least one diffraction grating positioned between the laser source and the lenticular sheet such that the incident laser beam passes through the diffraction grating before passing through the lenticular sheet.

[0016] In one embodiment, the system further comprises at least one diffraction grating positioned behind the lenticular sheet such that the incident laser beam passes through the diffraction grating after passing through the lenticular sheet.

**[0017]** In one embodiment, the lenticular sheet is placed in an upright position such that the plurality of parallel longitudinal lenses are oriented horizontally, and the at least one diffraction grating comprises at least one linear diffraction grating oriented such that a plurality of lines thereof are vertically oriented.

5 **[0018]** In one embodiment, the lenticular sheet is placed in an upright position such that the plurality of parallel longitudinal lenses are oriented at an angle to the horizontal plane, and the at least one diffraction grating comprises at least one linear diffraction grating oriented such that a plurality of lines thereof are vertically oriented.

10 **[0019]** In one embodiment, the lenticular sheet is placed in an upright position such that the plurality of parallel longitudinal lenses are oriented horizontally, and the at least one diffraction grating comprises at least one dual-axis diffraction grating oriented such that a first plurality of lines thereof are vertically oriented, and a second plurality of lines thereof are horizontally oriented.

15 **[0020]** In one embodiment, the lenticular sheet is placed in an upright position such that the plurality of parallel longitudinal lenses are oriented at an angle to the horizontal plane, and the at least one diffraction grating comprises at least one dual-axis diffraction grating oriented such that a first plurality of lines thereof are vertically oriented, and a second plurality of lines thereof are horizontally oriented.

20 **[0021]** In another aspect of the present disclosure, there is provided a system for manipulating two laser beams to form a cone. The system comprises a first laser source producing a first incident beam comprised of a plurality of rays projecting to a dot, a second laser source producing a second incident beam comprised of a plurality of rays projecting to a dot, and a double-sided lenticular sheet having a first lens side comprising a plurality of parallel longitudinal lenticular lenses and a second lens side comprising a plurality of  
25 parallel longitudinal lenticular lenses opposite the first lens side. The first laser source is

directed towards the first side of the lenticular sheet so that the first incident beam falls onto one of the plurality of parallel longitudinal lenticular lenses at an incident angle such that the majority of the first incident beam rays are reflected forming a first curved plane. The second laser source is directed towards the second side of the lenticular sheet so that the second incident beam falls onto an opposite side of the one of the plurality of parallel longitudinal lenticular lenses at the same incident angle as the first laser source such that the majority of the second incident beam rays are refracted forming a second curved plane. The first and second curved planes together form a cone projected as a circle.

**[0022]** In one embodiment, the double-sided lenticular sheet comprises a first and a second single-sided lenticular sheet each having a lens side and a smooth side, and wherein the first and second single-sided lenticular sheets are positioned back-to-back at their respective smooth sides.

**[0023]** In one embodiment, the system further comprises a sheet of bright opaque material disposed between the respective smooth sides of the first and second single-sided lenticular sheets.

**[0024]** In one embodiment, the sheet of bright opaque material comprises a double-sided mirror.

**[0025]** In one embodiment, the first lens side and the second lens side are coated with or made of reflective material.

**[0026]** In one embodiment, the smooth sides of the first and second single-sided lenticular sheets are coated with reflective material.

**[0027]** In yet another aspect of the present disclosure there is provided a system for manipulating two laser beams to form a cone. The system comprises a first laser source producing a first incident beam comprised of a plurality of rays projecting to a dot, a second

laser source producing a second incident beam comprised of a plurality of rays projecting to a dot, and a lenticular sheet having a first lens side comprising a plurality of parallel longitudinal lenticular lenses and a second lens side comprising a plurality of parallel longitudinal lenticular lenses opposite the first side. The first laser source is directed  
5 towards the first side of the lenticular sheet so that the first incident beam falls onto one of the plurality of parallel longitudinal lenticular lenses at a first incident angle such that the first incident beam rays are refracted and reflected to form a first cone. The second laser source is directed towards the second side of the lenticular sheet so that the second incident beam falls onto an opposite side of the one of the plurality of parallel longitudinal lenticular  
10 lenses at an incident angle greater than the first incident angle such that the second incident beam rays are refracted and reflected to form a second cone larger than the first cone and coaxial therewith.

**[0028]** In one embodiment, the first and second beams are spaced apart when they fall on the one of the plurality of parallel longitudinal lenticular lenses such that there is a  
15 distance between the apex of the first cone and the apex of the second cone.

**[0029]** In yet another aspect of the present disclosure, there is provided a method of detecting at least one object using a light detection and ranging (LIDAR) system. The method comprises projecting a first incident laser beam at a first angle onto a first lens side of a double-sided lenticular sheet for producing a first half cone of reflected rays, projecting  
20 a second incident laser beam at a second angle onto a second lens side of the double-sided lenticular sheet for producing a second half cone of reflected rays which, together with the first half cone of reflected rays forms a full cone of reflected rays, and detecting, by at least one sensor of the LIDAR system, signals reflected off at least one object when the at least one object crosses any one of the reflected rays of the full cone.

**[0030]** In one embodiment, the method further comprises varying the first angle and the second angle for changing the size of the first half cone and the second half cone, respectively.

**[0031]** In yet another aspect of the present disclosure, there is provided a system for diverting a laser beam. The system comprises a laser source for projecting an incident laser beam, a first lenticular sheet having a lens side comprising a plurality of parallel longitudinal lenticular lenses and a smooth side opposite the first side, and a second lenticular sheet having a lens side comprising a plurality of parallel longitudinal lenticular lenses and a smooth side opposite the first side. The first and second lenticular sheets are positioned such that the smooth side of the first lenticular sheet faces the smooth side of the second lenticular sheet and the first and second lenticular sheets form a double-sided lenticular sheet. The laser source projects the incident laser beam through the first and second lenticular sheets.

**[0032]** In one embodiment, the second lenticular sheet is positioned such that the plurality of lenticular lenses thereof are parallel to and offset from the plurality of lenticular lenses of the first lenticular sheet so as to cause an interference pattern between the two lenticular sheets for deviating the laser beam.

**[0033]** In one embodiment, the second lenticular sheet is positioned such that the plurality of lenticular lenses thereof are angled to the plurality of lenticular lenses of the first lenticular sheet so as to cause an interference pattern between the two lenticular sheets for deviating the laser beam.

**[0034]** In one embodiment, the system further comprises a double-sided lenticular sheet having a first lens side comprising a plurality of parallel longitudinal lenticular lenses and a second lens side comprising a plurality of parallel longitudinal lenticular lenses opposite the

first side, the double-sided lenticular sheet positioned to the front of or behind the first and second lenticular sheets with respect to the laser source.

**[0035]** In one embodiment, the first and second lenticular sheets are integrally formed.

**[0036]** In one embodiment, the first and second lenticular sheets, and the double-sided  
5 lenticular sheet are integrally formed.

**[0037]** A method of making a system for deviating a laser beam comprises providing a first lenticular sheet having a lens side comprising a plurality of parallel longitudinal lenticular lenses and a smooth side opposite the first side, providing a second lenticular sheet having a lens side comprising a plurality of parallel longitudinal lenticular lenses and a  
10 smooth side opposite the first side, and adhering the smooth side of the first lenticular sheet to the smooth side of the second lenticular sheet.

**[0038]** In one embodiment, the method further comprises, prior to said adhering,  
positioning the second lenticular sheet such that the plurality of lenticular lenses thereof are parallel to and laterally offset from the plurality of lenticular lenses of the first lenticular  
15 sheet.

**[0039]** In one embodiment, the method further comprises, prior to said adhering,  
positioning the second lenticular sheet such that the plurality of lenticular lenses thereof are angled to the plurality of lenticular lenses of the first lenticular sheet.

**[0040]** In one embodiment, the method further comprises providing a double-sided  
20 lenticular sheet having a first lens side comprising a plurality of parallel longitudinal lenticular lenses and a second lens side comprising a plurality of parallel longitudinal lenticular lenses opposite the first side, and adhering the double-sided lenticular sheet to the lens side of the first lenticular sheet or to the lens side of the second lenticular sheet such that the plurality of parallel longitudinal lenticular lenses of the double-sided lenticular sheet

are parallel to either the plurality of parallel longitudinal lenticular lenses of the first or second lenticular sheet.

### **Brief Description of the Drawings**

5 [0041] Embodiments of the present invention will be presented with reference to the accompanying drawings, in which:

[0042] FIG. 1 is a side perspective view of a system for scattering a laser beam aimed generally perpendicularly to a lens side of an upright singled-sided lenticular sheet having horizontally-oriented longitudinal lenticular lenses on the lens side thereof and an opposite  
10 smooth side;

[0043] FIG. 2 is a top-front perspective view of a system for scattering a laser beam aimed generally perpendicularly to a lens side of an upright single-sided lenticular sheet having vertically-oriented longitudinal lenticular lenses on the lens side thereof and an opposite smooth side;

15 [0044] FIG. 3 is a side perspective view of a system for scattering a laser beam aimed at a small angle with respect to the perpendicular to a lens side of an upright single-sided lenticular sheet having horizontally-oriented longitudinal lenticular lenses on the lens side thereof and an opposite smooth side, wherein the laser beam is generally in the same horizontal plane as the longitudinal lenticular lens on which it is projected;

20 [0045] FIG. 4 is a side perspective view of a system for scattering a laser beam aimed at a larger angle than the angle in FIG. 3 with respect to the perpendicular to a lens side of an upright lenticular sheet having horizontally-oriented longitudinal lenticular lenses on the lens side thereof and an opposite smooth side, wherein the laser beam is generally in the same horizontal plane as the longitudinal lenticular lens on which it is projected;

[0046] FIG. 5A is a side perspective view of a system for scattering a laser beam aimed at an larger angle but similar to that of FIG. 4 with respect to the perpendicular to a lens side of a single-sided upright lenticular sheet having horizontally-oriented longitudinal lenticular lenses on the lens side thereof and an opposite smooth side, wherein the laser beam forms an angle with the horizontal plane passing through the longitudinal lenticular lens on which it is projected;

[0047] FIG. 5B is a top view of a system for scattering a laser beam aimed at an angle with respect to the perpendicular to an upright lenticular sheet having horizontally-oriented longitudinal lenticular lenses on a lens side thereof and an opposite smooth side, the laser beam being aimed at the lens side of the lenticular sheet;

[0048] FIG. 6 is a top view of a system for scattering a laser beam aimed at an angle with respect to the perpendicular to an upright lenticular sheet having horizontally-oriented longitudinal lenticular lenses on a lens side thereof and an opposite smooth side, the laser beam being aimed at the smooth side of the lenticular sheet;

[0049] FIG. 7A is a side perspective view of a system for scattering two laser beams of different color each aimed at an opposing side of a double-sided lenticular sheet having horizontally oriented longitudinal lenticular lenses on each of its two opposite sides, wherein the two beams are aimed at both sides of a single location on a longitudinal lenticular lens on each of the opposite side, wherein each of the two laser beams forms an angle with respect to the perpendicular to a respective side of the lenticular sheet at the single location, and wherein both beams lie in the same horizontal plane passing through the longitudinal lenticular lens at which they are aimed;

[0050] FIG. 7B is a top view of the system of FIG. 7A but with the two colored laser sources swapped in position and each aimed at a larger angle with respect to the

perpendicular to a respective surface of the double-sided lenticular sheet, such that all incident rays are reflected;

[0051] FIG. 8A is a side perspective view of the system of FIG. 7B, wherein the two laser beams are of the same color;

5 [0052] FIG. 8B is a projection view of the circle formed by the laser beams of FIG. 8A, when projected on a flat surface at a far distance;

[0053] FIG. 8C is a schematic diagram depicting an airborne LIDAR system utilizing a laser cone to detect enemy ground troops;

10 [0054] FIG. 8D is a schematic diagram depicting a LIDAR system utilizing a laser cone used by a sniper to detect enemy ground troops;

[0055] FIG. 8E is a schematic diagram depicting a ground-based LIDAR system utilizing multiple laser cones to detect a missile;

[0056] FIG. 8F is a schematic diagram depicting an enemy aircraft being detected by an airborne LIDAR system utilizing a laser cone mounted in another fight aircraft;

15 [0057] FIG. 8G is a schematic diagram depicting an enemy aircraft about to be detected by a ground-based LIAR system utilizing a laser cone;

20 [0058] FIG. 9A is a top view of a system for scattering two laser beams of different color each aimed at an opposing side of a double-sided lenticular sheet having horizontally oriented longitudinal lenticular lenses on each of its two opposite sides, wherein the two beams are aimed at different locations on a longitudinal lenticular lens on each of the opposite sides, wherein each of the two laser beams forms a different angle with respect to the perpendicular to a respective side of the lenticular sheet, and wherein both beams lie in

the same horizontal plane passing through the longitudinal lenticular lens at which they are aimed;

[0059] FIG. 9B is a projection view of the circles formed by the laser beams of FIG. 9A, when projected on a flat surface at a far distance;

5 [0060] FIG 10A is a top view of a system for scattering a laser beam aimed at an angle with respect to the perpendicular to an upright lenticular sheet having horizontally-oriented longitudinal lenticular lenses on a lens side thereof and an opposite smooth side, the laser beam being aimed at the lens side of the lenticular sheet at such an angle that all rays of the laser beam are reflected off a lenticular lens on the lens side;

10 [0061] FIG. 10B is a top view of a system for scattering two laser beams each aimed at a corresponding lens side of two back-to-back single-sided lenticular sheets having horizontally oriented longitudinal lenticular lenses, wherein the two beams are aimed at both sides of a single location on a corresponding longitudinal lenticular lens on each of the opposite side, wherein each of the two laser beams forms the same angle with respect to the  
15 perpendicular to a respective side of the lenticular sheet at the single location, and wherein the two lenticular sheets are separated by a bright opaque sheet.

[0062] FIG. 11 is a flow chart for a method of detecting an object by a LIDAR system utilizing a double-sided lenticular sheet;

[0063] FIG. 12 is a top view of a linear diffraction grating;

20 [0064] FIG. 13 is a top view of a double-axis diffraction grating;

[0065] FIG. 14 is a perspective schematic diagram showing the spectrum produced by directing light from a white light source through a linear diffraction grating;

[0066] FIG. 15 is a side perspective view showing a plurality of beams produced as a result of shining a laser beam through a linear diffraction grating;

[0067] FIG. 16 is a side perspective view showing a plurality of beams produced as a result of shining a laser beam through a double axis diffraction grating;

5 [0068] FIG. 17 is a side perspective view showing system of producing a plurality of beam patterns by shining a laser beam through a linear diffraction grating with vertical lines, and a linear lenticular sheet with horizontally oriented lenticular lenses;

[0069] FIG. 18 is a side perspective view showing a system similar to that of FIG. 17 but wherein the lenticular sheet has been rotated by approximately 45 degrees with respect  
10 to the linear diffraction grating;

[0070] FIG. 19 is a side perspective view showing system of producing a plurality of beam patterns by shining a laser beam through a double-axis diffraction grating, and a linear lenticular sheet with horizontally oriented lenticular lenses;

[0071] FIG. 20 is a side perspective view showing a system similar to that of FIG. 19  
15 but wherein the lenticular sheet has been rotated by approximately 45 degrees with respect to the double-axis diffraction grating;

[0072] FIG. 21 is a side view showing a system of two back-to-back linear lenticular lenses having a horizontal offset between the lenses thereof, used to divert a laser beam;

[0073] FIG. 22 is a top view showing a system of two back-to-back linear lenticular  
20 lenses having an angular offset between the lenses thereof; and

[0074] FIG. 23 is a side view showing a system of two back-to-back linear lenticular lenses having aligned lenticular lenses with one another, used to divert a laser beam

### Detailed Description of the Embodiments

[0075] Embodiments of the present invention will now be presented by way of example only and not limitation. Utilizing lenticular lenses, the beam path of one or more laser device can be heavily modified to cause the laser beam(s) to turn into a flat plane, a lightly curved plane, a heavily curved plane, or a cone from the point where the beam hits the lenticular lens.

[0076] With reference to **FIG. 1**, a system **100** for manipulating a laser beam is depicted. The system **100** includes a laser source **110** that emits an incident laser beam **120** that forms a dot when projected on a surface. The incident laser beam **120** is aimed perpendicularly onto a linear lenticular sheet **150**. The linear lenticular sheet **150** has lens side **151**, and an opposite smooth side. The lens side **151** of the linear lenticular sheet **150** includes a plurality of longitudinal lenticular lenses **155** oriented in the horizontal direction. The incident laser beam **120** is generally narrow and focused that it projects on a single longitudinal lenticular lens **155**, or on a small number of adjacent lenticular lenses **155**, on the lens side **151** of lenticular sheet **150**. This depends on the density of the lenticular sheet **150**, which is measured in lens-per-inch or LPI. For a lenticular sheet with a low lens density, all of the rays of incident laser beam **120** may all fall onto a single longitudinal lenticular lens **155**. However, for a lenticular sheet **150** with a high lens density, the rays of the incident laser beam **120** fall onto a plurality of adjacent lenticular lenses **155**. The individual rays of the incident laser beam **120** each undergoes refraction at a different angle by the longitudinal lenticular lens or lenses **155**. The resulting rays **125** are diverted such that they are spread out and are projected out from the opposite smooth side of the lenticular sheet **150** in the form of a plurality of rays forming a triangular flat plane **128**. Upon projecting on a flat surface, the diverted rays **125** form a vertical line pattern **130**. The lenticular sheet used in **FIG. 1** has a relatively high lens density. A further observation of the line **130** shows that the line **130** is comprised of a plurality of closely spaced dots. A small number of rays **127** of the incident laser beam **120** are reflected off the surface of

lenticular lens **155** in the form of a very narrow triangular flat plane. The rays **127** form a small line **132** when projected on a flat surface on the same side as the laser source **110**.

[0077] The orientation of the line pattern **130** formed by the spreading out of the incident laser beam **120** by refraction of its rays through the longitudinal lenticular lens or lenses **155** depends on the orientation of the longitudinal lenticular lens or lenses **155** on which the incident laser beam **120** is projected. In **FIG. 1**, the lenticular sheet is oriented such that the lenticular lenses **155** are oriented horizontally and the resulting line pattern **130** is vertical. **FIG. 2** depicts a system **100**, similar to the system **100** of **FIG. 1**, except that the lenticular sheet **150** is placed in an upright position and is oriented such that the plurality of longitudinal lenticular lenses **155** are vertically oriented. When laser source **110** projects the incident laser beam **120** onto a vertically oriented longitudinal lenticular lens or lenses **155** of the lenticular sheet **150**, the rays of the incident laser beam **120** are refracted by the lenticular lens **155** to produce diverted rays **126** in the form of a triangular flat plane **129**. When projected on a flat surface, the rays **126** form a horizontal line **135** pattern behind the smooth side of the lenticular sheet **150**. The lenticular sheet **150** used in **FIG. 2** has a low lens density, and accordingly the line pattern **135** is shown as a single line. However, similar to line pattern **130**, line pattern **135** is comprised of a plurality of closely spaced dots.

[0078] In both **FIG. 1** and **FIG. 2**, the laser beam **120** is perpendicular to the lenticular sheet. Accordingly, the effect of the lenticular lens **155** on the laser beam **120** is symmetrical. **FIG. 3** depicts a system **100** for diverting a laser beam **120** similar to that of **FIG. 1** with the exception that the laser beam **120** is aimed at the lens side **151** of the lenticular sheet **150** at a horizontal angle of incidence  $\Theta$  relative to the perpendicular direction to the lens side **151** which is depicted by the line **184**. The angle of incidence  $\Theta$  is such that the overwhelming majority of the rays of the incident laser beam **120** are refracted by the longitudinal lenticular lens or lenses **155** in the form of the diverted rays **135**. Only a small number of rays of the incident laser beam **120** are reflected by the longitudinal lenticular lens or lenses **155** in the form of the reflected rays **137**. The incident laser beam

**120** is maintained in the horizontal plane passing through lenticular the lens **155** on which it is aimed. The angled orientation of the laser beam **120** with respect to the lenticular lens **155** causes the individual rays of laser beam **120** passing through the lenticular lens **155** to undergo refraction in two different general directions. Due to the curved (convex) shape of the lenticular lens **155**, the rays of laser beam **120** tend to be diverted (refracted) in the vertical direction as was seen in **FIG. 1**. Moreover, due to the angle of incidence  $\Theta$  by which the laser beam **120** is oriented with respect to the direction perpendicular to lenticular lens **155**, the individual rays of laser beam **120** tend to be additionally refracted in the horizontal direction. Since the rays of the incident laser beam **120** fall on different regions of the lenticular lens **155** each having a generally different thickness (due to the curvature of the lenticular lens surface), therefore each of the rays of laser beam **120** gets refracted by a different angle in the horizontal direction. As a result, the diverted rays **125** which emerge from the smooth side of the lenticular lens **155** end up taking a shape of a curved plane **138** (in the form of a partial cone) which when falling onto a flat surface projects an arc pattern **140**. A minority of the rays of the incident laser beam **120** are reflected off the lens side surface of the lenticular lens **155**. The reflected rays **137** form a curved plane on the same side of the lenticular sheet **150** as the laser source **110**. When projected on a flat surface the reflected rays **137** projected a small arc **142**.

[0079] **FIG. 4** depicts a system **100** similar to the system of **FIG. 3** with the exception that the angle of incidence  $\Theta$  of beam **120** onto lenticular sheet **150**, with respect to the perpendicular **184**, is greater than that of **FIG. 3**. When the angle of incidence  $\Theta$  is increased a greater number of the rays of the incident laser beam **120** are reflected off the lens side of the lenticular lens **155** surface and are shown as the reflected rays **137**. The reflected rays **137** form a curved plane that projects as an arc **162**, which is in the shape of a partial ellipse. The curved plane formed by the reflected rays **137** and the corresponding projected arc **162** are on the same side of lenticular sheet **150** as the laser source **110** to the front of sheet **150**. A smaller number of rays, depending on the angle of incidence  $\Theta$  of the

incident laser beam **120** with respect to the perpendicular **184**, pass through the lenticular lens **155**, are refracted in a curved manner as described above, and project an arc **160** behind the lenticular sheet **150**. The resulting projected pattern is an ellipse **165** comprised of arcs **160** and **162** complementing one another. The ellipse **165** is a projection of an ellipsoidal cone formed by the reflected rays **137** and the refracted rays. It has been observed that when the lenticular sheet is perpendicular to the surface (e.g. wall) upon which the laser pattern is projected, that the ellipse **165** projects close to a perfect circle, and accordingly, the reflected rays **137** and refracted rays **135** together form a perfect cone, as shown in **FIG. 5A**.

**[0080]** **FIG. 5A** shows a variation on the system **100** of **FIG. 4**. The incident laser beam **120** has an angle of incidence of  $\Theta$  with respect to a perpendicular direction **184** to the lenticular lens **155** of the lenticular sheet **150**. Additionally the incident laser beam **120** is angled by an angle  $\beta$  with respect to the horizontal plane passing through the lenticular lens **155**, depicted as the plane passing through lines **184** and **185**. The surface upon which the resulting refracted ray **135** and reflected rays **137** are projected is perpendicular to the lenticular sheet **150**. Accordingly, the refracted and reflected rays form close to a perfect circular cone **180** projecting as a circle comprised of the arcs **160** and **162**. The angle  $\beta$  causes the circle to be shifted upwards with respect to the lenticular sheet **150**, as shown. The rays **135** and **137** together are shaped like a cone **180** which projects a circle, however, the cone is partially projected in front of the lenticular sheet **150** and partially projected behind it due to the fact that is partly formed of reflected rays and partly formed of refracted rays. Accordingly, a laser cone may be formed by using a laser source **110** and a lenticular sheet **150**. The cone may be directed up and down by changing the angle  $\beta$  with respect to the horizontal plane as discussed.

**[0081]** **FIG. 5B** is a top perspective view showing a laser beam **120** aimed at a wide angle to the lens side of lenticular sheet **150** wherein the lenticular lenses **155** run parallel to the horizontal plane passing through the laser beam **120**. The arc **162** to the left is produced by the beam **120** reflecting off the lenticular lens **155** on the left (lens) side of sheet **150** in

the form of reflected rays **127** that project as arc **162**. Conversely, the refracted arc **160** to the right is produced by the beam **120** refracting through the lenticular lens **155** and exiting at the smooth side of lenticular sheet **150** as rays **125** that project as the arc **160**.

5 [0082] The above results show that laser planes or cones can be produced as the beam is spread out from the lenticular material into the shape such as lines **130** and **135**, arcs **140** and **142**, and arcs **160** and **162**. Unlike some prior art methods where an incident laser beam may be utilized to produce shapes by spinning mirrors, the system **100** presented herein has no moving parts. Various lines, arcs, and cone shapes may be produced solely by changing the angle of the laser beam with respect to the lenticular sheet.

10 [0083] It should be noted that while previous figures have shown the laser beam being directed at the lens side of the lenticular sheet, the system has also been operated while projecting the laser beam on the smooth side of the lenticular sheet instead. For example, with reference to **FIG. 6**, the beam **120** is aimed at the smooth side **152** of a single-sided lenticular sheet **150**. In this case the left arc **160** formed is due to the beam refracting  
15 through the sheet and exiting at a lenticular lens **155** on the lens side of the sheet as rays **135** which form arc **160**. Conversely, the arc **162** to the right of the figure is formed due to the laser beam **120** reflecting off the smooth side of lenticular sheet **150** as rays **137** that form arc **162**. Additionally, a bright dot **167** is also formed in the middle of arc **162** due to the beam **120** undergoing direct reflection off the smooth side of lenticular sheet **150**. It has  
20 been observed that the refracted arc **160** is brighter than the reflected arc **162**. The exception is the bright dot **167** on the reflected arc. This has shown that it is preferred to use the lens side **151** of a lenticular sheet to generate laser cones. It has also been observed that the bright dot **167** is movable along the arc **162** as the beam **120** is angled by a small degree with respect to the lenticular sheet **150**. Furthermore, the intensity of the bright dot **167**  
25 increases as the angle of the beam **120** with respect to the smooth surface of the lenticular sheet **150** is closer to being perpendicular to that surface. The observation made with respect to the bright dot **167** being movable along the arc **162**, is an indication that small

changes to the angle of the incident laser beam **120** to the lenticular lens **155** causes the rays **137** and **135** to rotate. In essence, changing the angle of incidence resizes the cone and in doing so, all the dots on arcs **160** and **162** rotate circumferentially as they spread in or out as the cone is being resized. For example, decreasing the angle of incidence  $\Theta$  by a small amount causes the rays **137** and **135** to produce a slightly larger cone **180**. As the individual dots forming arcs **160** and **162** move towards their newer position they are also moving circumferentially. The opposite happens when the angle of incidence  $\Theta$  is increased; the cone **180** decreases and the individual dots forming arcs **160** and **162** rotate in the opposite direction as they move to their newer positions. This has been confirmed to apply also when the incident laser beam is directed at the lens side **151** of the lenticular lens. The rotation of the dots (and accordingly the beams projecting the dots) was initially observed with respect to the smooth side **152** due to the presence of the bright dot **167**, but it applies to all dots forming arcs **160** and **162**. Accordingly, tiny adjustments to the angle of incidence  $\Theta$  can be used to move the points circumferentially. This has a significant advantage when it comes to discussing the applications of the generated laser cone.

**[0084]** There are benefits of spreading a laser beam and/or projecting various lines, arcs, and elliptical shapes that have laser rays in the form of laser planes, curves or cones. For example, a security system that uses a thin, focused laser beam is likely to be triggered by any small object blocking the beam. Accordingly, many false positive triggers may occur because of an insect, a small bird, or a rodent passing through the beam. However, if the beam is spread to become a plane (projected as a line), a curved plane (projected as an arc), or a cone (projected as a circle), then it could take a larger object such as a human, a drone, or a vehicle to block a larger portion of the beam and trigger an alert condition. Since conditions may change or vary for various areas, the sizes of the planes and cones can also vary. Advantageously, changing the dimensions of the laser planes or cones are a simple matter of changing the angle and/or position of projection of the incident laser beams on the lenticular lens. Additionally or alternatively, different lenticular sheets may be used each

with different viewing angles or lens density (LPI). For example, a lenticular sheet with a different viewing angle may produce a projected laser cone or plane with different dimensions for the same laser beam or beams projected with the same angle thereon.

[0085] With reference to **FIGS. 7A** and **7B**, there is provided a system **200** for projecting a laser cone **180**. The system **200** is comprised of two laser sources **210a** and **210b**, and a double-sided lenticular sheet **170**. The double-sided lenticular sheet **170** has a plurality of longitudinal lenticular lenses **175** on both sides thereof. The laser source **210a** projects an incident laser beam **220a** having a first color, and the laser source **210b** projects an incident laser beam **220b** having a second color different from the first color. For example, the laser beam **220a** may be green while the laser beam **220b** may be red. The incident laser beams **220a** and **220b** are both aimed at opposite sides of the double-sided lenticular sheet **170**, and with different angles of incidence. The incident laser beam **220a** is reflected off one side of lenticular lens **175a** of lenticular sheet in the form of the rays **137**. When the rays **137** fall on or meet a flat surface, they project an arc **180a** to the front of the lenticular sheet **170**. The incident laser beam **220b**, on the other hand, is projected at the opposite side of lenticular lens **175a** at a smaller angle of incidence relative to the perpendicular direction to the lenticular sheet **170**. As such, beam **220b** projects on the rear side of the lenticular sheet **170** and is reflected off the lenticular lens **175a**. The rays that reflect off the lens **175a** and are reflected as rays **135**, form a curved surface such as a partial cone and project an arc **180b** to the front of the lenticular sheet. Advantageously, the two arcs **180a** and **180b** are complementary as long as the two beams are projected at opposite sides of the same location on a particular lenticular lens of the double-sided lenticular sheet **170**. The resulting ray configuration comprised of rays **135** and rays **137** ~~475~~ **170** is in the shape of a cone **180**. The angle of incidence of incident laser beam **220a** is chosen so that most of the rays are reflected as rays **137**, whereas the angle of incident laser beam **220b** is chosen so that most of the rays are reflected in a higher concentration as rays **135**. If the

angle of incidence of laser source **210a** is great enough, laser beam **220a** will go through the lenticular sheet **170** and refract in an arc on the other side near or on top of arc **180b**.

**[0086]** In **FIG. 7B** the angles of incidence of incident laser beams **220a** and **220b** are both large such that both beams are reflected off of the respective surfaces of the double-sided lenticular lens **170**. The resulting laser cone **180** is thus quite narrow, but is comprised  
5 entirely of reflected rays.

**[0087]** **FIG. 8A** shows a system **300** in which the two laser sources **310a** and **310b** project laser beams **320** and **320b** of the same color. Accordingly, the resulting cone **180** appears to come from the same laser source although it is a composite of the reflected rays  
10 **137** from the incident laser beam **320a** and the refracted rays **137** from the incident laser beam **320b**. The result is a laser cone **180** comprised of the two half laser cones **180a** and **180b** that are of a single color. The laser cone **180** has a number of useful applications, as indicated below.

**[0088]** **FIG. 8B** shows that the laser cone **180**, produced by the system **300** of **FIG. 8A**  
15 for example, when projected at a surface which is far away from the laser source is actually comprised of a plurality of rays projecting as circumferential dots **182**. Typical arcs and cones are composed of many hundreds of dots. However, as has been discussed with respect to **FIG. 6**, minor adjustments of angle of incidence of the incident laser beams cause the dots **182** to rotate circumferentially (either clockwise or counter clockwise).  
20 Accordingly, this can be used to detect objects that would normally pass undetected between the rays projecting those dots, as discussed below.

**[0089]** LIDAR (Light Detection and Ranging) currently utilizes a pulsed laser or lasers to bounce a signal off the surrounding environment, and a sensor for detecting the reflected signals. Accordingly, by measuring the time that signal takes to reflect back to the sensor, a  
25 computer may determine the distance to objects and/or create a three-dimensional map of

the surrounding area and surface characteristics. Topographic LIDAR uses near-infrared lasers to map the land, and Bathymetric LIDAR uses green lasers to penetrate the water and map the sea floor and riverbeds. The use of LIDAR through water is, however, often limited to only tens of feet. LIDAR is a key component of self-driving cars and the more accurate the LIDAR, the safer the system can be. LIDAR is also being tested in aircraft to determine regions of turbulence in front of the aircraft to allow the aircraft to avoid or prepare for those areas. LIDAR could also be used by a civilian body or the military to search for targets, shallow underwater, on the ground, or in the air (cloudless) or in space. Low observable aircraft, drones, birds, and bats, which are difficult to detect by radar, may be detected by this type of system.

**[0090]** Utilizing the above-described systems to create a flat plane, curved plane and/or a cone, instead of a laser point, much more detail could be determined by the sensor to increase the effectiveness over a shorter period of time and a greater angle may be achieved than current LIDAR systems. In one embodiment, a laser cone could be made variable from narrow to wide to scan a large portion of the sky while sensors would pick up any reflection off of other aircraft, aircraft contrails, aircraft turbulence, natural turbulence, drones, missiles, projectiles, rockets, bullets, balloons, birds, bats or swarms of insects.

**[0091]** **FIG 8C** shows a laser cone **180** comprised of a plurality of rays **137** produced by an airborne LIDAR system and being used to detect ground troops. **FIG. 8D** shows a laser cone, used by a LIDAR system used by a sniper to detect one or more enemy troops. **FIG. 8E** shows a land-based LIDAR system utilizing 3 laser cones **180** each comprised of a plurality of rays **137**. The land-based LIAR is used to detect a missile. **FIG. 8F** depicts a laser cone produced by an airborne LIDAR system used to detect an enemy aircraft. **FIG. 8G** depicts a ground-based LIDAR system projecting a cone **180** for detecting an aircraft. The cones shown in **FIGS. 8C-8G** are comprised of a plurality of rays as discussed above, which project as a circle as shown in **FIG. 8B**. Typical arcs and cones are composed of many hundreds of dots. In order to ensure that the object to be detected does not pass

between two circumferentially adjacent rays, the rays are moved circumferentially such that each ray sweeps the circumferential arc between its present location and the location of an adjacent ray. In one embodiment, this is accomplished by tiny adjustments of laser source to change the angle of incidence of the incident laser beam or beams with respect to the lenticular lens. In another embodiment, the lenticular sheet is slightly moved or rotated to change the angle of incidence of the incident laser beam or beams so that the refracted rays are slightly rotated circumferentially as discussed.

[0092] FIG. 9A shows a system 200 comprised of a double-sided lenticular sheet 170, and two laser sources 210a and 210b. The laser source 210a projects the incident laser beam 220a, and laser source 210b projects the incident laser beam 220b. The laser beam 220a produces a reflected arc 270a and a refracted arc 270b as described earlier. Similarly, the laser beam 220b produces a reflected arc 280a and a refracted arc 280b. The laser beam 220b is angled to the perpendicular direction 184 on the lenticular sheet 170 by an angle that is greater than that of laser beam 220a. Accordingly, the arcs 280a and 280b produced by the incident laser beam 220b are bigger in dimension than the arcs 270a and 270b produced by the incident laser beam 220a. Consequently the laser cone 280 formed by the reflected and refracted rays from beam 220b is larger than the laser cone 270 formed by the reflected and refracted rays from beam 220a. Since beams 220a and 220b are projected at either sides of the same lenticular lens, then the two cones are coaxial. In the depicted embodiment, the laser beams are directed at different lateral spots of the lenticular lens, which are spaced apart horizontally by a distance (d). The resulting cones are therefore nested such that an object traveling inside cone 280 may be detected by cone 270. The laser source 210a may be moved in a horizontal plane to vary the distance (d). Accordingly, the size and position of cone 270 with respect to cone 280 varies. The resulting effect is that the entire volume between the cone 270 and 280 may be swept and covered by laser rays that may be used to detect any object between the cones.

[0093] In one embodiment, the laser source **210a**, for example may be moved back and forth to sweep the volume between cone **270** and **280**, and additionally, the laser source **210** may have its angle of incidence slightly altered to rotate the rays forming cone **270**. For example with reference to **FIG. 9B**, the dots **271** represent the rays of cone **270** when projected on a flat surface. Similarly, the dots **281** represent the rays of cone **280** when projected on a flat surface. If the laser source **210a** is moved such that the distance (**d**) in **FIG. 9A** is smaller than cone **270** expands so the dots **271** move closer to dots **281**. Furthermore, if laser source **210a** is angled slightly causing each dot **271** to rotate to the location previously occupied by an adjacent dot, then the volume between cones **270** and **280** is completely covered for object detection in both the radial and the circumferential directions. In another embodiment, the laser source **210b** is moved such that the cone **280** is made smaller, and laser source **210a** is moved such that cone **270** is made smaller until it is nearly diminished. This is done by angling laser source **210a** until it is at a large obtuse angle (close to 180 degrees) from the perpendicular direction to the lenticular sheet **170**. Accordingly, the entire volume encompassed by laser cone **280** is swept for object detection. For example, the cone **270** may be half the size of cone **280** and it may take the same time for cone **280** to be reduced in size to match the initial size of cone **270** as it takes for cone **270** to be nearly diminished in size. During that time, the entire volume of cone **280** is swept radially. Alternatively, a few more laser sources may be added and aimed such that their respective beams are also displaced from one another by a distance such as (**d**). Accordingly, a number of concentric cones may be utilized to cover the volume encompassed by the outermost laser cone **280**. In such embodiment, it may not be necessary to vary the sizes of the laser cones, and it may be sufficient to simply rotate them so that each cone area is swept circumferentially.

[0094] A stationary laser cone could also be rotated like a radar or LIDAR does rather than variable changing of the cone angle. LIDAR often uses mirrors to rapidly spin a laser source and the same could occur with these lines, arcs or cones. A combination of rotation

of the cone and variable angling of the cone from narrow to wide may also be used and more than one laser may be used for multiple cones of similar or different angles may be used with the same lens or other lenses to increase the area being scanned. The laser cone may be stationary with more than one laser being used for multiple cones of varying angles.

5 In space, this system could be used to detect other space-based objects, whether natural (meteorites, asteroids, comets...) or artificial (satellites, spacecraft, astronauts, space junk...).

[0095] With reference to **FIG. 10A**, a system **100** similar to that shown in **FIGS. 1-6** can be used to produce a partial laser cone that projects as an arc **140**. The laser source **110** projects an incident laser beam **120** angled by a large angle  $\Theta$  relative to the line **184** perpendicular to the surface of the lens side **151** of a single-sided lenticular sheet such as sheet **150**. This produces a reflection only of the rays of the incident laser beam **120**, in the form of reflected rays **127** that project as arc **140**. As discussed above, further increasing the angle  $\Theta$  leads to the arc eventually being diminished entirely.

15 [0096] It has been observed that in order to produce a circular cone produced by reflection only of laser beams off a double-sided lenticular sheet **170**, that the incident angle of the incident laser beam **120** needs to be large with respect to the perpendicular direction on the lenticular sheet. If the angle is not large enough, then part of the rays are refracted and another part is reflected. The resulting pattern may be two cones instead of one. In the system shown in **FIG. 10B**, the double-sided lenticular sheet **170** has been replaced by two back-to-back single sided lenticular lens sheets **150** and a sheet of bright opaque material **160** or a mirror inserted therebetween. In this configuration, the bright opaque material or mirror prevents refraction of laser beams through the lenticular lens sheets and instead reflects the beams. Accordingly, the resulting pattern may be a larger cone as the angle may be larger than, for example, the angle used in **FIG. 10A**.

20

25

[0097] FIG. 10C shows a system similar to that of FIG. 10B, but uses two back-to-back lenticular sheets 250 each having a highly reflective lens side. For example, the lenticular lenses of the lenticular sheets 250 may be made from a highly reflective material or have a highly reflective coating. The high reflectiveness of the lens side prevents  
5 refraction of laser beams through the lenticular lens sheets and instead reflects the beams. Accordingly, the resulting pattern may be a larger cone as the angle may be larger than, for example, the angle used in FIG. 10A.

[0098] The laser sources may be moved slightly to the left or to the right with respect to the lenticular sheet to cause the dots to move clockwise or counterclockwise. Given the  
10 proximity of each projected dot to the ones adjacent thereto, very little movement by the laser source may be required to have each dot cross the gap to the next adjacent dot position. Another possible embodiment is to move the lenticular sheet itself. Very little movement by the sheet would be needed to move the dots to cross the gap. In one embodiment, the lenticular sheet may be in the form of a cylinder, which can be slightly movable. A simple  
15 gear and spring mechanism may be utilized to create a slow and steady movement. For example, a winding mechanism similar to old wind-up watches may be used. The mechanism may include reduction gears to provide a slow but steady turning motion to rotate one of the laser sources and the lenticular material used to divert the laser beams of the laser sources. If the mechanism is applied to the first laser source to move it slightly to  
20 the left or to the right, then a second laser source may be required to offset the stopping of the dots as the first laser source reaches the far left or far right point while the second laser is in the middle of a sweep. Utilizing a spinning mirror may also spin the line, arc or cone.

[0099] Experiments have shown the regardless of the shape, a stealth type aerial vehicle cannot effectively scatter electromagnetic energy lying at the smaller wave lengths of light  
25 emitted by LIDAR. A fast moving jet aircraft or a new hypersonic missile may be able to fly through gaps between the diverted laser rays discussed, but it is highly unlikely to be able to do so if the rays forming the cones discussed are also moving clockwise or counter

clockwise accomplished by either moving the lenticular lenses or the laser sources. Additionally, turbulence produced by such vehicles may also be detected by LIDAR.

[00100] FIG. 11 depicts a method 1100 for detecting an object using a LIDAR system. At step 1110, a first incident laser beams is projected onto a first lens side of a double-sided lenticular sheet for producing a first half cone of reflected rays. At step 1120, a second incident laser beam is projected at a second angle onto a second lens side of the double-sided lenticular sheet for producing a second half conde of reflected rays that, together with the first half-cone of reflected rays forms a full cone of reflected rays. At step 1130, a sensor of the LIDAR system, detects signals reflected off an object when that object crosses any one of the reflected rays of the full cone.

[00101] FIG. 12 is a top plan view of a diffraction side of a linear (single axis) diffraction grating 1000 having a plurality of lines 1010. The opposite side of the diffraction grating 1000 is a smooth flat surface. FIG. 13 is a top plan view of a diffraction side of a double-axis diffraction grating 1500 having a plurality of horizontal lines 1010 and a plurality of vertical lines 1020. The opposite side of the double-axis diffraction grating 1500 is a smooth flat surface.

[00102] FIG. 14 shows an incident light beam 20 is aimed towards the smooth surface of the diffraction grating 1000 at an angle to the normal. The different colored light of rays comprising the beam 20 are refracted in the same manner as they would have been refracted off of a prism and decomposed into rays 21, 22, 23, and 24 of different colors.

[00103] FIG. 15 is a side perspective view showing an incident laser beam 120 being directed through a single axis diffraction grating 1000. The single axis diffraction grating 1000 causes the beam 120 to produce a plurality of diffracted laser beams 1024 which when projected on a flat surface such as a wall produce a plurality of dots 1025 arranged in a line

along that surface. It has been observed, with a particular type of laser source used that a diffraction grating of **1000** lines per millimeter (l/mm), three dots were formed.

**[00104]** **FIG. 16** is a side perspective view showing an incident laser beam **120** being directed through a double axis diffraction grating **1500**. The double axis diffraction grating **1500** causes the beam **120** to produce a plurality of diffracted laser beams **1024** which when projected on a flat surface such as a wall produce a plurality of dots **1025** arranged in a matrix shape on that surface.

**[00105]** Turning back to **FIG. 1** when an incident laser light beam **120** was aimed generally perpendicularly to a linear lenticular sheet **150** in which the lenticular elements **155** were horizontally oriented, the resulting pattern was a beam formed as a triangle and which projected as a vertical line **130** on a flat surface. Each vertical line **130** is in fact comprised of hundreds of dots that are closely spaced. If the plurality of laser beams **1024** from **FIG. 15** are passed through a lenticular sheet **150** such as that of **FIG. 1** then each one of the diffracted laser beams **1024** of **FIG. 15** would produce a line such as line **130** of **FIG. 1**. With reference to **FIG. 17**, a laser source **110** directs an incident laser beam **120** through a linear diffraction grating **1000** oriented such that the diffraction lines are vertical, followed by a linear lenticular sheet **150** placed behind and abutting the diffraction grating **1000**, with the lenticular lenses oriented horizontally. The resulting pattern is a plurality of triangular vertical planes projecting as vertical lines **1080**. A close examination of the vertical lines shows that each line is formed of a hundreds of closely spaced points. The number of vertical lines depends on the pattern density of the diffraction grating. Accordingly, the number of vertical lines projected may be increased.

**[00106]** With respect to **FIG. 18**, if the lenticular lens sheet **150** is rotated such that it is angled with respect to the diffraction grating **1000** then the points projected by the diffraction grating no longer line up vertically and each one of them produces a line when passed through the linear lenticular sheet. The resulting pattern is the same number of

diagonal triangular laser planes projecting as diagonal lines **1090** and which are closely spaced. Again, each one of the diagonal lines **1090** is comprised of hundreds of points.

**[00107]** The diffraction grating used in **FIG. 19** is a double-axis diffraction grating **1500**, in accordance with an embodiment of the present disclosure. As discussed earlier with respect to **FIG. 16**, a matrix of laser beams projecting as a matrix of laser dots is formed when an incident laser beam **120** is projected through a double-axis diffraction grating **1500**. For example, if a double axis diffraction grating had a pattern density of 13,500 lines per inch, a matrix pattern of 13x13 dots has been observed to be projected by the diffracted laser beams. If a lenticular sheet **150** with a plurality of lenses is placed in the path of the diffracted laser beams **1024**, then each beam produces a line as shown earlier. If the lenticular sheet is placed such that the lenticular lenses are horizontally oriented, then many of the lines **1080** line up and one sees a few substantially bright lines.

**[00108]** In **FIG. 20**, the lenticular sheet **150** is rotated by an angle relative to the double-axis diffraction grating **1500**. Accordingly, the matrix of dots produced by the diffraction grating is now oriented diagonally to the lenticular sheet **150**. The resulting pattern is the plurality of lines **1090**, which are diagonal. The lines **1090** are more than lines **1080** and are more closely spaced. Each of the lines **1090** is comprised of hundreds of dots.

**[00109]** It has been observed that adding more diffraction grating sheets with different pattern densities in the path of the incident laser beams, produces more diffracted beams forming dots. Passing the diffracted beams through a lenticular sheet, as discussed, converts each dot into a line, with each line made up of hundreds or even thousands of dots. An object coming into the path of the plurality of beams is in the path of thousands of laser beams and can be detected with good resolution using LiDAR systems. Additionally, a LIDAR system utilizing thousands of laser beams in the form of a matrix is very sensitive to even small objects. The thousands of laser beams are closely spaced even at farther distances, which may avert the need for performing sweeps similar to those performed with

laser cones. The limiting factor of the number of diffraction gratings to be used is the amount of laser light that manages to go through and its intensity. A stronger laser may still shine enough power to be usable even with a number of diffraction gratings, while a weaker laser may only be used in conjunction with a few diffraction gratings. The application of the LIDAR system may dictate the strength of the laser used, and accordingly the number of diffraction gratings, their pattern density, and their angle in relation to each other and in respect to the lenticular lens. Additionally, the distance to the objects to be detected may dictate the number of gratings to use. For example, for objects that are not far enough, a few number of gratings may be used as the resulting lines and dots are still closely spaced at a near distance. However, for detecting objects that are far away, more gratings producing, with the lenticular sheet, more beams that are closely spaced would be desirable. A stronger laser is needed in that case as more gratings reduce the amount of laser light passing through which affects the ability to detect an object using LIDAR.

**[00110]** FIG. 21 shows a system of diverting a laser beam by using two back-to-back linear lenticular sheets **150** and **450**, with an offset interference pattern therebetween. As shown the individual lenticular lenses of sheet **150** are laterally offset from those of sheet **450** in the horizontal direction. An incident laser beam **120** aimed at lenticular sheet **450** is diverted as it exits the lenticular sheet **150** as diverted beam **125**. The interference pattern therefore deviates the laser beam. This is beneficial since in modern warfare laser designators are often used to mark a target. This is done for laser guided bombs, missiles, and precision artillery munitions. By deviating the laser designator, there is a chance that the weapon will miss a vulnerable point of the target, such as a battle tank, which often requires a direct hit in a particular location to incapacitate it.

**[00111]** Lasers are also increasingly being used by ground forces to aim their weapons at the enemy. These lasers can operate in frequencies outside of the visible spectrum, and can be seen through night vision scopes or goggles. The material used in FIG. 21 works to

deviate lasers not only in the visible spectrum, but also those in the UV (Ultraviolet), NIR (Near Infrared) and SWIR (Short Wave Infrared) and potentially beyond this range

[00112] Deviating the pinpoint accuracy of a laser can also result in the soldier aiming at the wrong place and consistently missing the target without understanding why they cannot hit it. With the disruptive element of the interference concealing the target's status, the enemy may not even be aware that they completely missed the target, assuming they hit it. This may cause the enemy to change their offensive or defensive posture or position to allow the concealed target behind our material, to easily locate and identify the combatant and target that adversary while they are most vulnerable. With the system of **FIG. 21**, moving a laser beam to the right causes it to deflect to the left, and vice versa. This is depicted by the arrows, which show that the deflected laser beam **125** moves in the opposite direction as that of the incident laser beam **120**. An observer aiming at a target may notice that the projected laser dot on the target is moving in the opposite direction as that of the direction in which the laser source is being moved. Accordingly, the observer may suspect that some form of camouflage material is present in front of the target, and conclude that the target will not be hit precisely when ammunition is fired at the target using the observed dot.

[00113] **FIG. 22** depicts an alternate arrangement for two back-to-back linear lenticular sheets **150** and **450**. In this arrangement, the individual lenticular lenses of sheet **150** are angled to those of sheet **450** in the horizontal direction, which produces an interference pattern that deviates an incident laser beam passing therethrough.

[00114] **FIG. 23** shows a system of diverting a laser beam by using two back-to-back linear lenticular sheets **150** and **450**, with an offset interference pattern therebetween, and an additional double-sided lenticular sheet **170**. As shown the individual lenticular lenses of sheet **150** are offset from those of sheet **450** in the horizontal direction. The double-sided lenticular sheet **170** is shown positioned between the laser source and lenticular sheets **450** and **150**, however lenticular sheet **170** may also be positioned behind the lenticular **150** and

450. An incident laser beam 120 aimed at lenticular sheet 450 exits the lenticular sheet 150 as a diverted beam as was the case in FIG. 21, however that diverted beam now passes through double-sided lenticular sheet 170. In this case, the beam is diverted by when the laser source is moved in a particular direction, the diverted beam 125 moves in the same direction. Advantageously, the diverted beam does not project on the intended target, but at the same time an observer may not suspect that the beam is being diverted since as they move the laser source, the projected laser dot appears to move in the same direction. Accordingly, the observer may be under the impression that the target has been hit when ammunition is fired in the direction of the observed projected dot.

10 [00115] While the lenticular lenses have been drawn with substantially the same dimensions, it will be apparent to those of skill in the art, that different lenticular sheets with different angles or lenses-per-inch (LPI) may be used interchangeably without affecting the way in which the invention works.

15 [00116] While the lenticular sheets used in the exemplary embodiments comprised longitudinal lenticular sheets, other equivalent refractive-reflective material may be usable. For example, prism lenses, dove prism lenses, and dove prism lenses split in the middle may be used.

20 [00117] For all systems described herein that use lenticular lenses, and/or diffraction grating, the surfaces thereof may be coated or manufactured with protective elements that may counter some or all of the following including but not limited to: fog, water, fire, dirt, dust, scratches, heat, cold, and ultraviolet radiation.

[00118] Having thus described, by way of example only, embodiments of the present invention, it is to be understood that the invention as defined by the appended claims is not to be limited by particular details set forth in the above description of exemplary

embodiments as many variations and permutations are possible without departing from the scope of the claims.

What is claimed is:

1. A system for diverting a laser beam, comprising:

a laser source emitting an incident laser beam comprising a plurality of rays projecting as a dot;

5 a lenticular sheet having a lens side comprising a plurality of parallel longitudinal lenticular lenses and a smooth side opposite the lens side;

at least one diffraction grating having at least one dual-axis diffraction grating oriented such that a first plurality of lines thereof are oriented at a non-zero orientation angle relative to a second plurality of lines thereof;

10 wherein:

the laser source is aimed towards the lens side of the lenticular sheet such that the incident laser beam falls onto at least one of the plurality of parallel longitudinal lenticular lenses,

15 a first portion of the plurality of rays of the incident laser beam is diverted by refraction to form a refracted beam of a first shape, and

a second portion of the plurality of rays of the incident laser beam is reflected by a surface of the at least one of the plurality of parallel longitudinal lenticular lenses to form a reflected beam of a second particular shape.

20 2. The system of claim 1, wherein the laser source is aimed so that the first incident laser beam falls perpendicularly onto the at least one of the plurality of parallel longitudinal lenticular lenses, the first portion of the incident the laser beam diverted by refraction represents a majority of the plurality of rays of the incident

laser beam, and the refracted beam of the first particular shape is in the form of a triangular plane beam projected as a straight line.

3. The system of claim 2, wherein the lenticular sheet is placed in an upright position such that the plurality of parallel longitudinal lenses are oriented horizontally, the triangular plane beam is vertically oriented, and the projected straight line is vertical.

4. The system of claim 2, wherein the lenticular sheet is placed in an upright position such that the plurality of parallel longitudinal lenticular lenses are oriented vertically, the triangular plane beam is horizontally oriented, and the projected straight line is horizontal.

5. The system of claim 1, wherein the laser source is aimed so that the incident laser beam falls at an angle of incidence to a perpendicular direction onto the at least one of the plurality of parallel longitudinal lenticular lenses such that the first portion of the plurality of rays of the first incident laser beam diverted by refraction represents a majority of the plurality of rays of the first incident laser beam, the first incident laser beam is in the same plane as a horizontal plane passing through the at least one of the plurality of parallel longitudinal lenticular lenses, and the refracted beam of a particular shape is in the form of a curved plane projected as an arc.

6. The system of claim 1, wherein the laser source is aimed so that the first incident laser beam falls at an incident angle off of a perpendicular direction onto the at

**AMENDED SHEET**

least one of the plurality of parallel longitudinal lenticular lenses such that the first and second portions together form a cone projecting to a circle.

5 7. The system of claim 1, wherein the lens side of the lenticular sheet is coated with reflective material such that the second portion of the plurality of rays reflected by the surface of the at least one of the plurality of longitudinal lenticular lenses comprises all of the plurality of rays of the incident laser beam.

10 8. A method of claim 1, wherein an anti-reflective layer or coating is disposed on at least one of the lens side and the smooth side of the lenticular sheet for reducing the second portion of the plurality of rays of the incident laser beam which is reflected by the surface of the at least one of the plurality of longitudinal lenticular lenses.

9. The system of claim 1, wherein the at least one diffraction grating is positioned between the laser source and the lenticular sheet such that the incident laser beam passes through the diffraction grating before passing through the lenticular sheet.

15 10. The system of claim 1, wherein the at least one diffraction grating is positioned behind the lenticular sheet such that the incident laser beam passes through the diffraction grating after passing through the lenticular sheet.

20 11. The system of claim 9 or claim 10, wherein the lenticular sheet is placed in an upright position such that the plurality of parallel longitudinal lenses are oriented horizontally, and the at least one diffraction grating comprises at least one linear

**AMENDED SHEET**

diffraction grating oriented such that a plurality of lines thereof are vertically oriented.

- 5 12. The system of claim 9 or claim 10, wherein the lenticular sheet is placed in an upright position such that the plurality of parallel longitudinal lenses are oriented at an angle to the horizontal plane, and the at least one diffraction grating comprises at least one linear diffraction grating oriented such that a plurality of lines thereof are vertically oriented.
- 10 13. The system of claim 9 or claim 10, wherein the lenticular sheet is placed in an upright position such that the plurality of parallel longitudinal lenses are oriented horizontally, and the at least one dual-axis diffraction grating is oriented such that the first plurality of lines thereof are vertically oriented, and the second plurality of lines thereof are horizontally oriented.
- 15 14. The system of claim 9 or claim 10, wherein the lenticular sheet is placed in an upright position such that the plurality of parallel longitudinal lenses are oriented at an angle to the horizontal plane, and the at least one dual-axis diffraction grating is oriented such that the first plurality of lines thereof are vertically oriented, and the second plurality of lines thereof are horizontally oriented.
- 20 15. A system for manipulating two laser beams to form a cone, comprising:  
a first laser source producing a first incident beam comprised of a plurality of rays projecting to a dot;

**AMENDED SHEET**

a second laser source producing a second incident beam comprised of a plurality of rays projecting to a dot;

5 a double-sided lenticular sheet having a first lens side comprising a plurality of parallel longitudinal lenticular lenses and a second lens side comprising a plurality of parallel longitudinal lenticular lenses opposite the first lens side;

wherein:

10 the first laser source is directed towards the first side of the lenticular sheet so that the first incident beam falls onto one of the plurality of parallel longitudinal lenticular lenses at an incident angle such that the majority of the first incident beam rays are reflected forming a first curved plane;

15 the second laser source is directed towards the second side of the lenticular sheet so that the second incident beam falls onto an opposite side of the one of the plurality of parallel longitudinal lenticular lenses at the same incident angle as the first laser source such that the majority of the second incident beam rays are refracted forming a second curved plane;

the first and second curved planes together form a cone projected as a circle.

20 16. The system of claim 15, wherein the double-sided lenticular sheet comprises a first and a second single-sided lenticular sheet each having a lens side and a smooth side, and wherein the first and second single-sided lenticular sheets are positioned back-to-back at their respective smooth sides.

**AMENDED SHEET**

17. The system of claim 16, further comprising a sheet of bright opaque material disposed between the respective smooth sides of the first and second single-sided lenticular sheets.
18. The system of claim 17, wherein the sheet of bright opaque material comprises a double-sided mirror.
19. The system of claim 15, wherein the first lens side and the second lens side are coated with or made of reflective material.
20. The system of claim 16, wherein the smooth sides of the first and second single-sided lenticular sheets are coated with reflective material.
21. A system for manipulating two laser beams to form a cone, comprising:
- a first laser source producing a first incident beam comprised of a plurality of rays projecting to a dot;
  - a second laser source producing a second incident beam comprised of a plurality of rays projecting to a dot;
  - a lenticular sheet having a first lens side comprising a plurality of parallel longitudinal lenticular lenses and a second lens side comprising a plurality of parallel longitudinal lenticular lenses opposite the first side;
- wherein:
- the first laser source is directed towards the first side of the lenticular sheet so that the first incident beam falls onto one of the plurality of parallel

**AMENDED SHEET**

longitudinal lenticular lenses at a first incident angle such that the first incident beam rays are refracted and reflected to form a first cone; and

5 the second laser source is directed towards the second side of the lenticular sheet so that the second incident beam falls onto an opposite side of the one of the plurality of parallel longitudinal lenticular lenses at an incident angle greater than the first incident angle such that the second incident beam rays are refracted and reflected to form a second cone larger than the first cone and coaxial therewith.

10 22. The system of claim 21, wherein the first and second beams are spaced apart when they fall on the one of the plurality of parallel longitudinal lenticular lenses such that there is a distance between the apex of the first cone and the apex of the second cone.

23. A method of detecting at least one object using a light detection and ranging (LIDAR) system, the method comprising:

15 projecting a first incident laser beam at a first angle onto a first lens side of a double-sided lenticular sheet for producing a first half cone of reflected rays;

projecting a second incident laser beam at a second angle onto a second lens side of the double-sided lenticular sheet for producing a second half cone of reflected rays which, together with the first half cone of reflected rays forms a full cone of reflected rays;

20 detecting, by at least one sensor of the LIDAR system, signals reflected off at least one object when the at least one object crosses any one of the reflected rays of the full cone.

24. The method of claim 23, further comprising varying the first angle and the second angle for changing the size of the first half cone and the second half cone, respectively.

25. A system for diverting a laser beam, comprising:

- 5 a laser source for projecting an incident laser beam;
- a first lenticular sheet having a lens side comprising a plurality of parallel longitudinal lenticular lenses and a smooth side opposite the first side; and
- a second lenticular sheet having a lens side comprising a plurality of parallel longitudinal lenticular lenses and a smooth side opposite the first side;

10 wherein:

the plurality of parallel longitudinal lenticular lenses of the first lenticular sheet are offset relative to the plurality of parallel longitudinal lenticular lenses of the second lenticular sheet;

15 the first and second lenticular sheets are positioned such that the smooth side of the first lenticular sheet faces the smooth side of the second lenticular sheet and the first and second lenticular sheets form a double-sided lenticular sheet; and

the laser source projects the incident laser beam through the first and second lenticular sheets.

20 26. The system of claim 25, wherein the second lenticular sheet is positioned such that the plurality of lenticular lenses thereof are parallel to and laterally offset from the plurality of lenticular lenses of the first lenticular sheet as to cause an interference pattern between the two lenticular sheets for deviating the laser beam.

**AMENDED SHEET**

27. The system of claim 25, wherein the second lenticular sheet is positioned such that the plurality of lenticular lenses thereof are angled to the plurality of lenticular lenses of the first lenticular sheet so as to cause an interference pattern between the two lenticular sheets for deviating the laser beam.
- 5 28. The system of claim 26 or claim 27, further comprising a double-sided lenticular sheet having a first lens side comprising a plurality of parallel longitudinal lenticular lenses and a second lens side comprising a plurality of parallel longitudinal lenticular lenses opposite the first side, the double-sided lenticular sheet positioned to the front of or behind the first and second lenticular sheets  
10 with respect to the laser source.
29. The system of claim 26 or claim 27, wherein the first and second lenticular sheets are integrally formed.
30. The system of claim 28, wherein the first and second lenticular sheets, and the double-sided lenticular sheet are integrally formed.
- 15 31. A method of making a system for deviating a laser beam, comprising:  
providing a first lenticular sheet having a lens side comprising a plurality of parallel longitudinal lenticular lenses and a smooth side opposite the first side;  
providing a second lenticular sheet having a lens side comprising a plurality of parallel longitudinal lenticular lenses and a smooth side  
20 opposite the first side;

**AMENDED SHEET**

adhering the smooth side of the first lenticular sheet to the smooth side of the second lenticular sheet to form a double-sided lenticular sheet;

5 wherein the plurality of parallel longitudinal lenticular lenses of the first lenticular sheet are offset relative to the plurality of parallel longitudinal lenticular lenses of the second lenticular sheet.

10 32. The method of claim 31, further comprising, prior to said adhering, positioning the second lenticular sheet such that the plurality of lenticular lenses thereof are parallel to and laterally offset from the plurality of lenticular lenses of the first lenticular sheet.

33. The method of claim 31, further comprising, prior to said adhering, positioning the second lenticular sheet such that the plurality of lenticular lenses thereof are angled to the plurality of lenticular lenses of the first lenticular sheet.

15 34. The method of claim 32 or 33, further comprising:  
providing another double-sided lenticular sheet having a first lens side comprising a plurality of parallel longitudinal lenticular lenses and a second lens side comprising a plurality of parallel longitudinal lenticular lenses opposite the first side; and

20 adhering said another double-sided lenticular sheet to the lens side of the first lenticular sheet or to the lens side of the second lenticular sheet such that the plurality of parallel longitudinal lenticular lenses of the

**AMENDED SHEET**

double-sided lenticular sheet are parallel to either the plurality of parallel longitudinal lenticular lenses of the first or second lenticular sheet.

35. The system of claim 1, wherein the at least one dual-axis diffraction grating comprises a first linear diffraction grating having the first plurality of lines and a  
5 second linear diffraction grating having the second plurality of lines.

36. The system of claim 1, wherein the non-zero orientation angle is 90 degrees.

37. The system of claim 25, further comprising at least one diffraction grating having at least one dual-axis diffraction grating oriented such that a first plurality of lines thereof are oriented at a non-zero orientation angle relative to a second plurality  
10 of lines thereof.

38. The system of claim 37, wherein the at least one dual-axis diffraction grating comprises a first linear diffraction grating having the first plurality of lines and a second linear diffraction grating having the second plurality of lines.

39. The system of claim 25, wherein the non-zero orientation angle is 90 degrees.

15 40. The method of claim 31, further comprising: providing at least one dual-axis diffraction grating oriented such that a first plurality of lines thereof are oriented at a non-zero orientation angle relative to a second plurality of lines thereof.

**AMENDED SHEET**

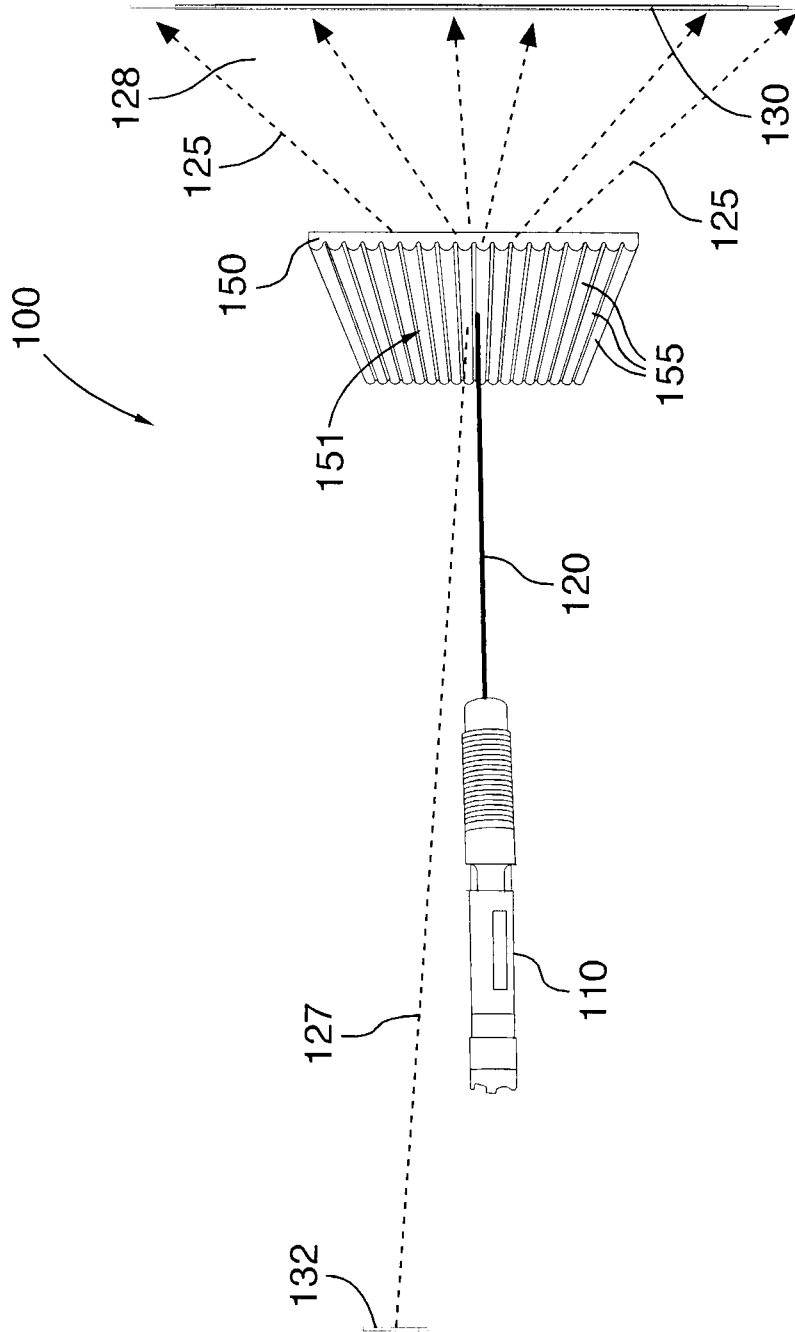

FIG.1

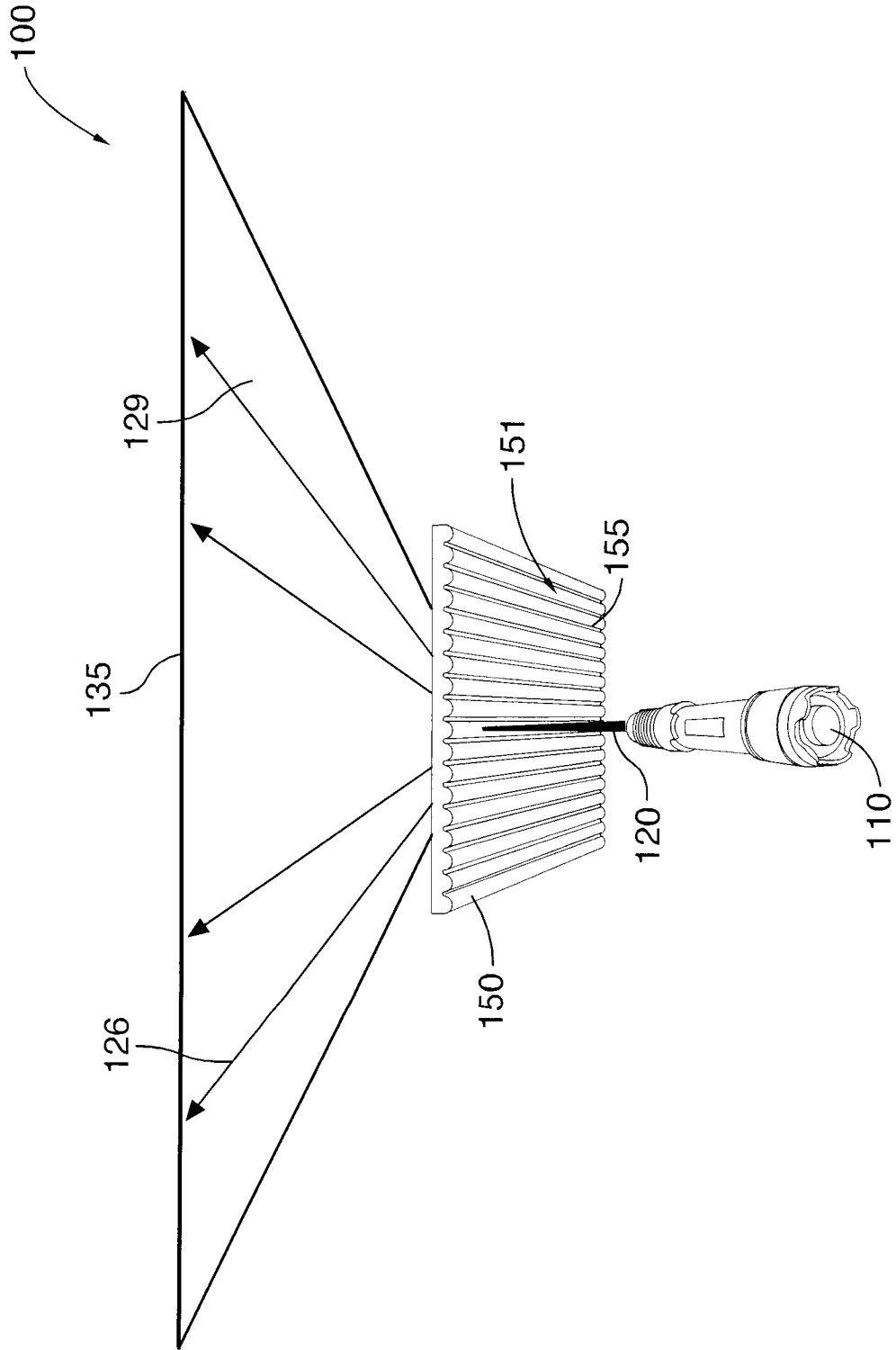

FIG.2

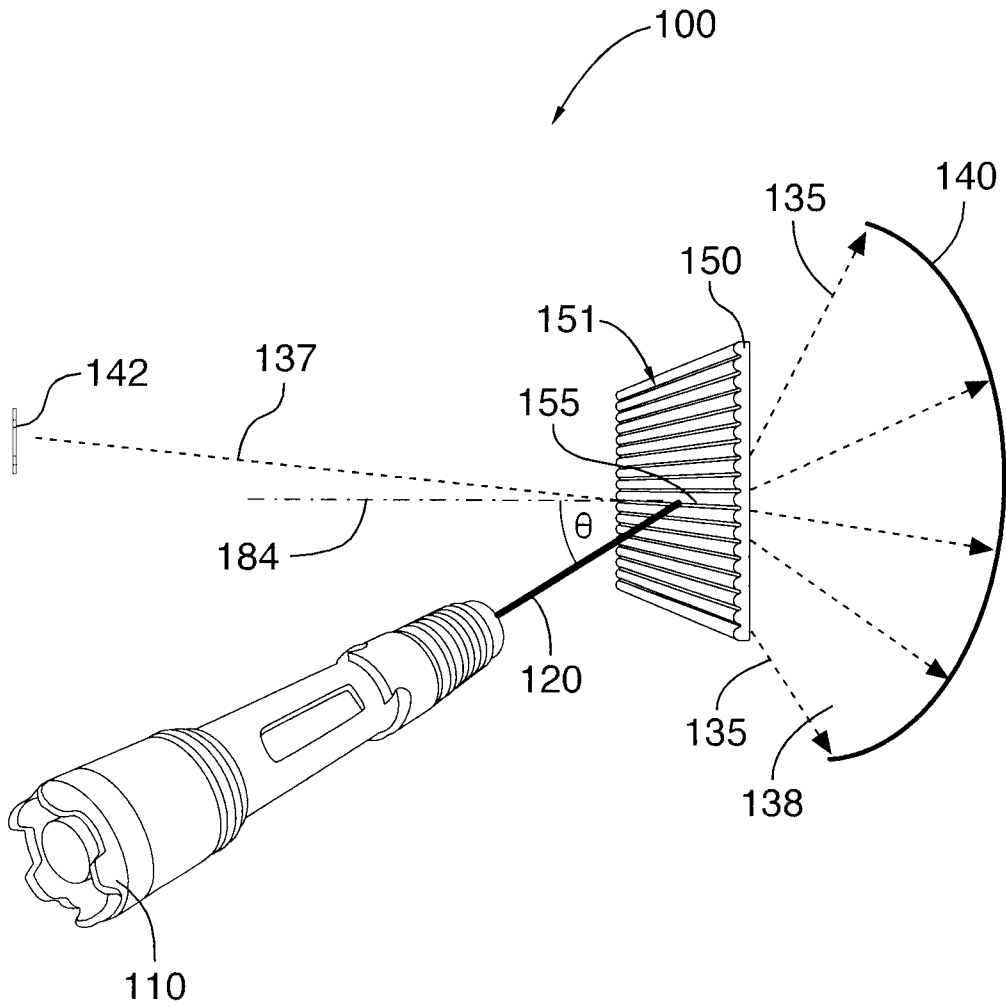

FIG.3

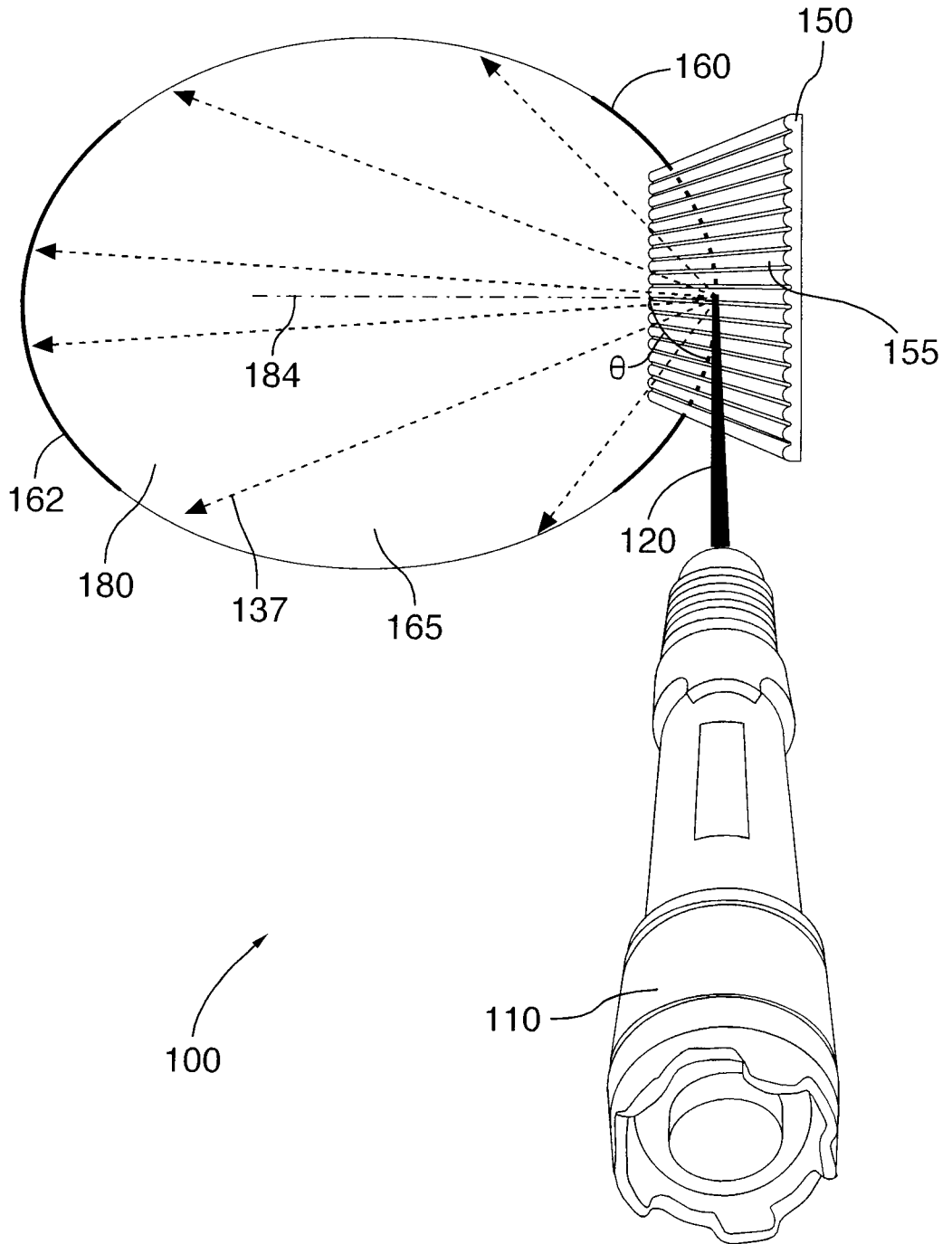

FIG.4



6/29

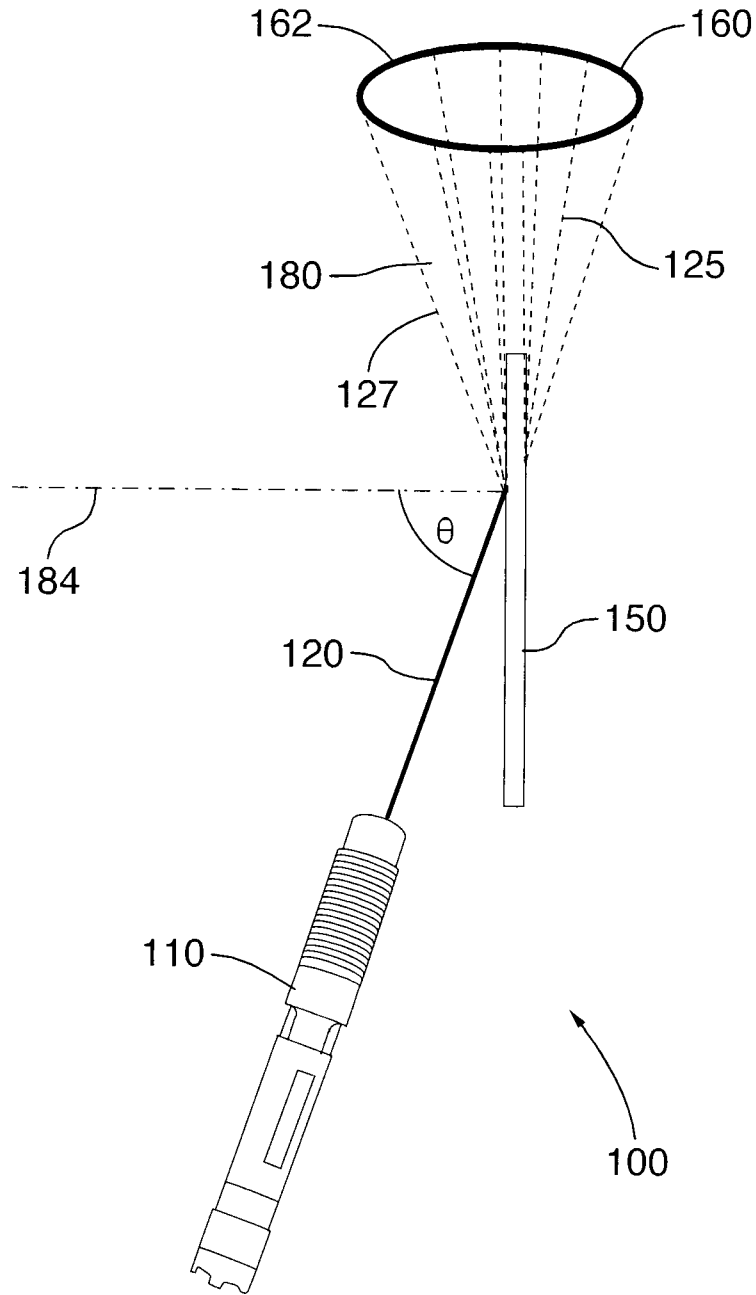

FIG.5B

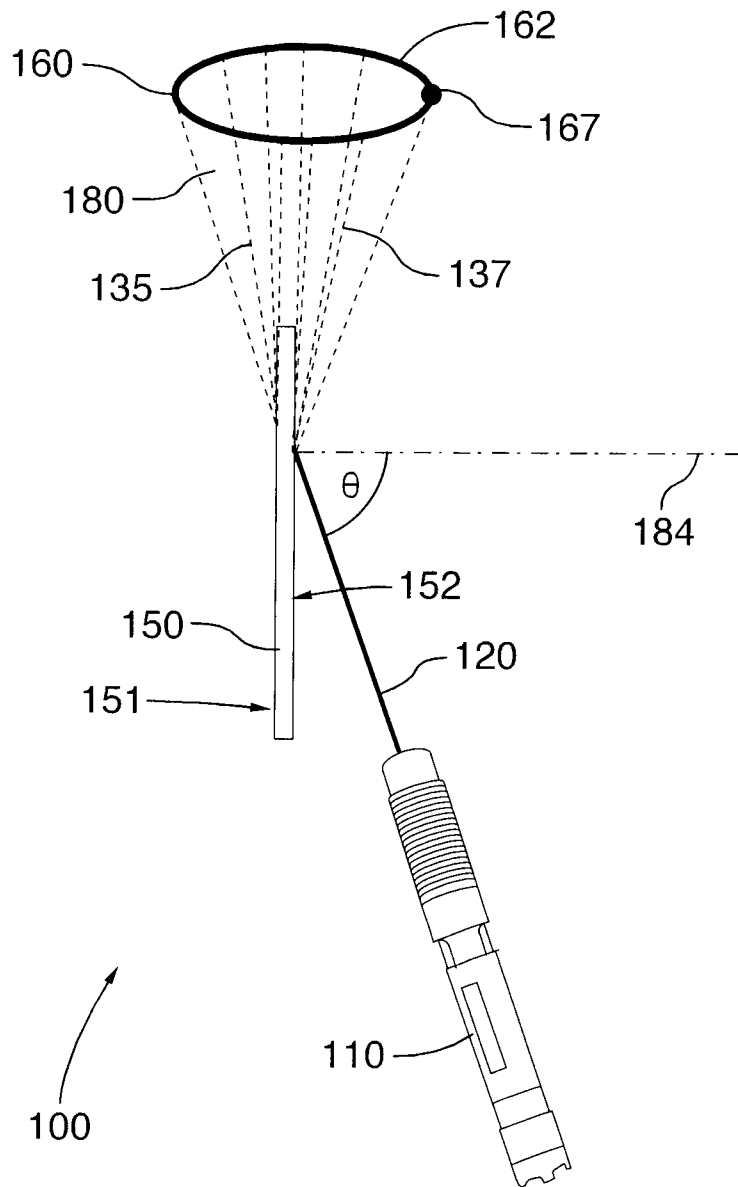

FIG.6

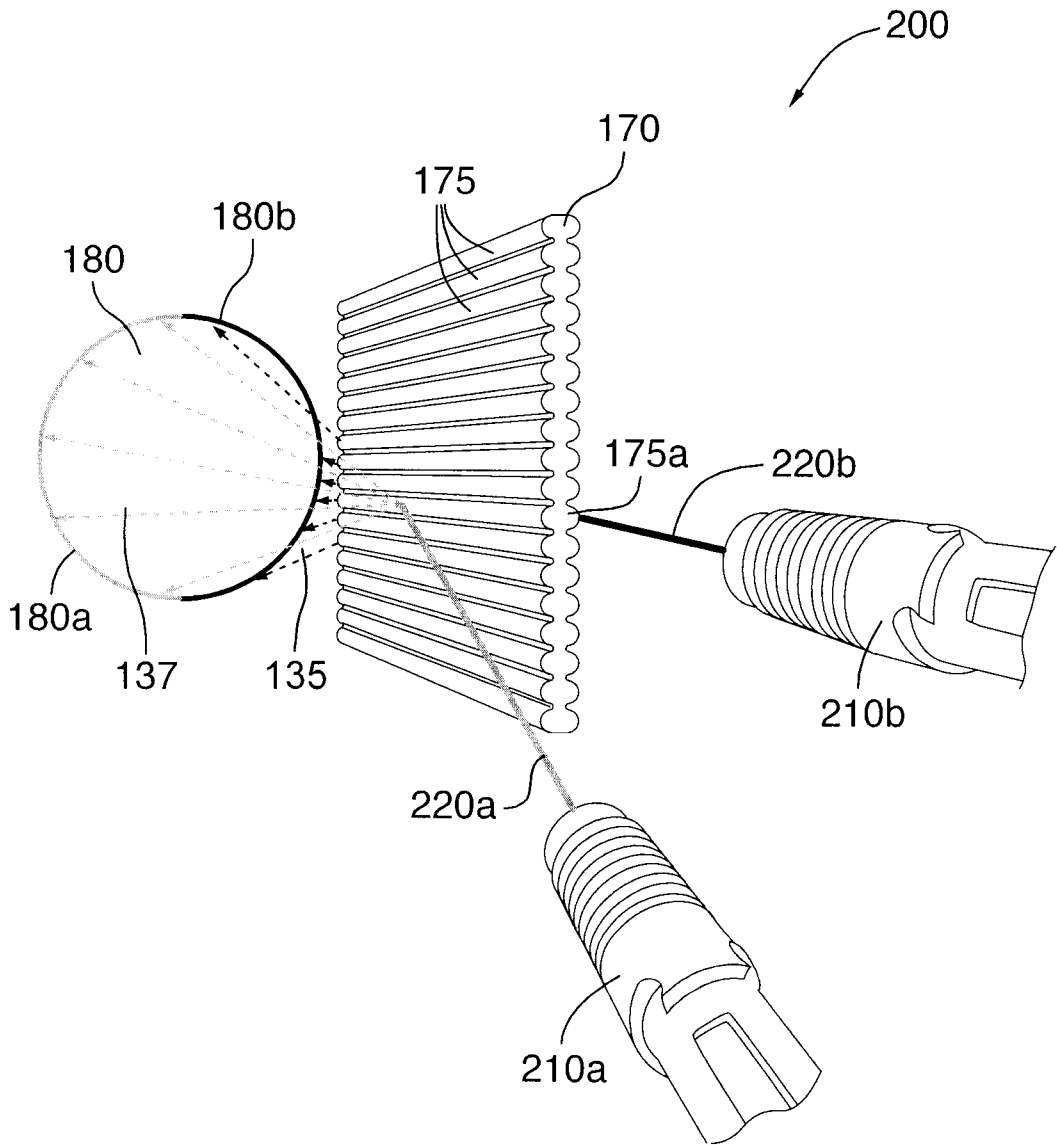

FIG.7A

9/29

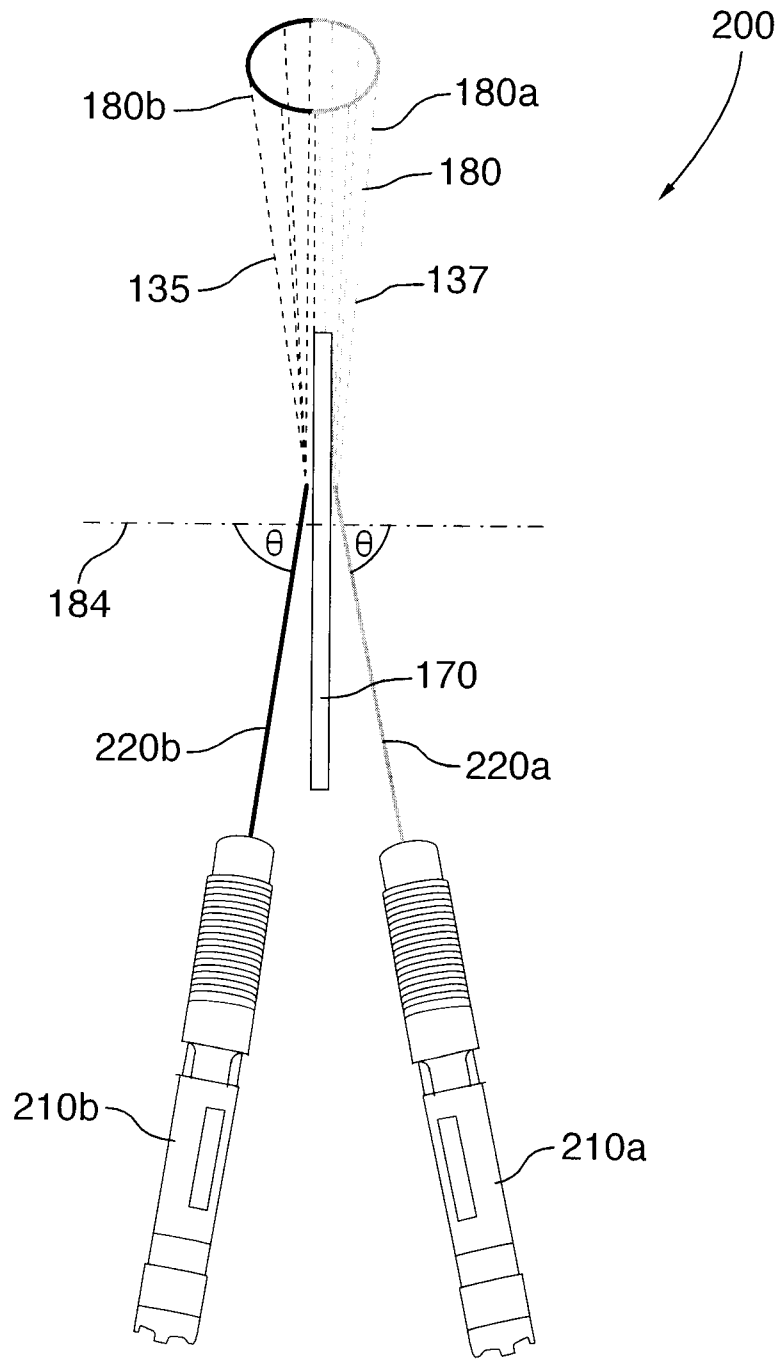

FIG.7B

10/29

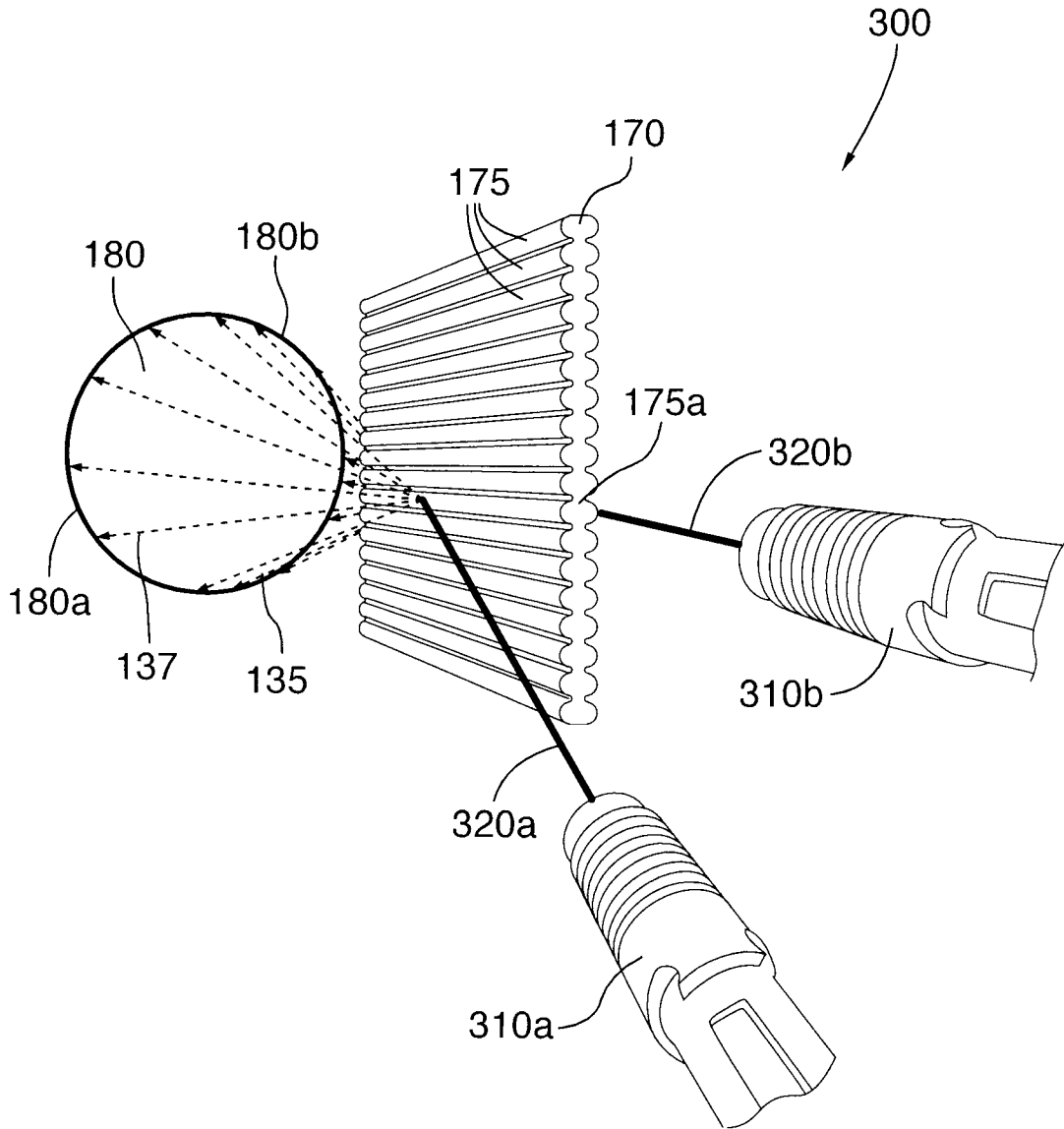

FIG.8A

11/29

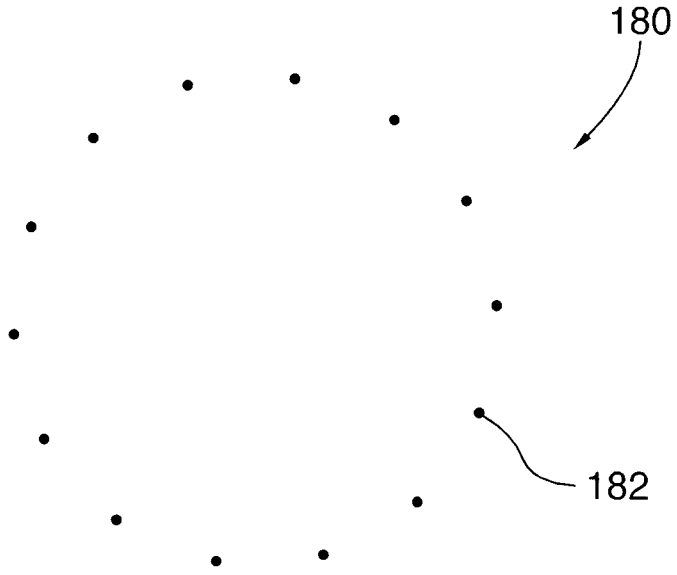

FIG.8B

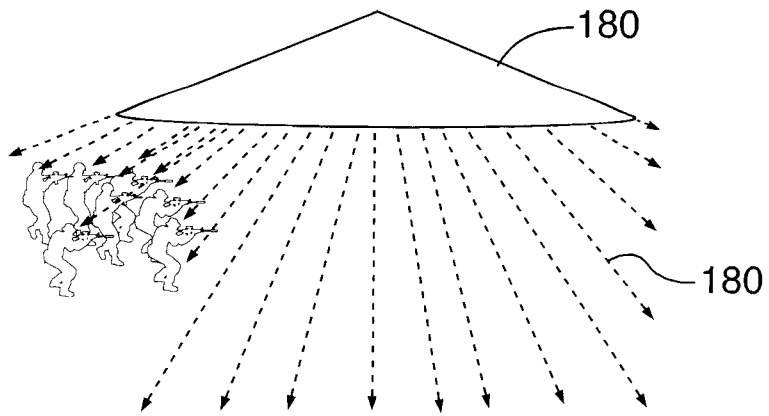

FIG.8C

12/29

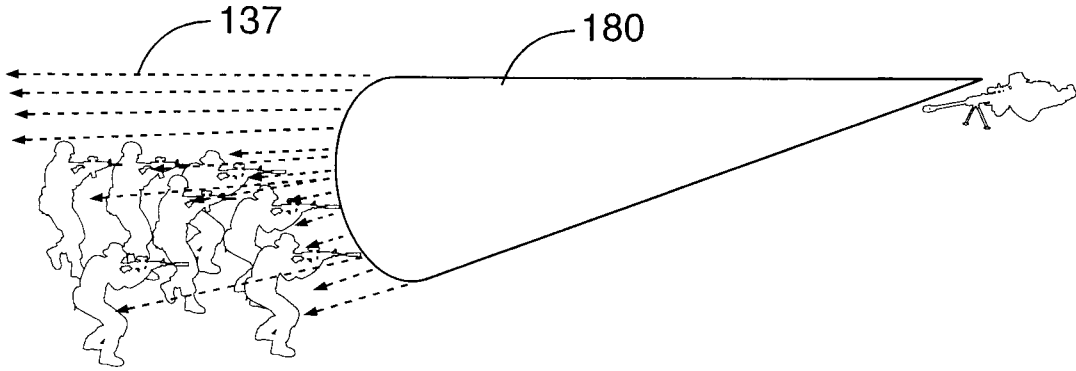

FIG. 8D

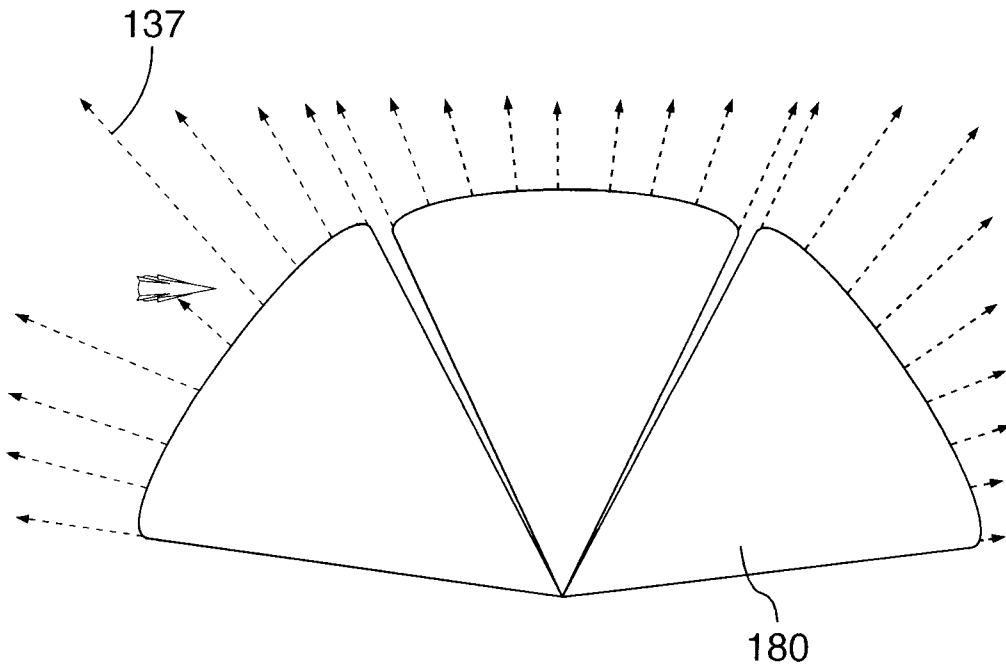

FIG. 8E

13/29

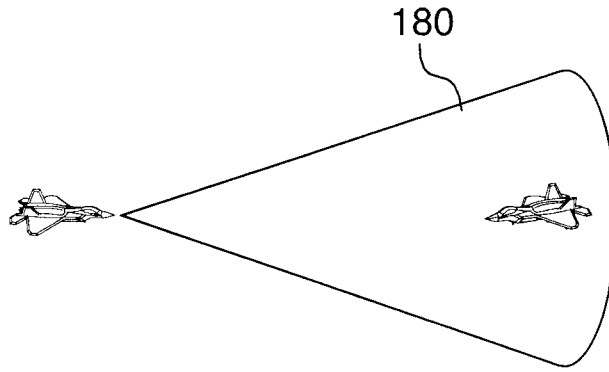

FIG. 8F

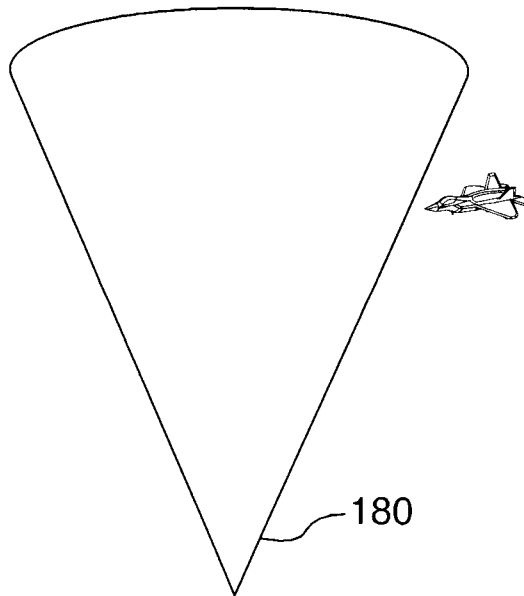

FIG. 8G



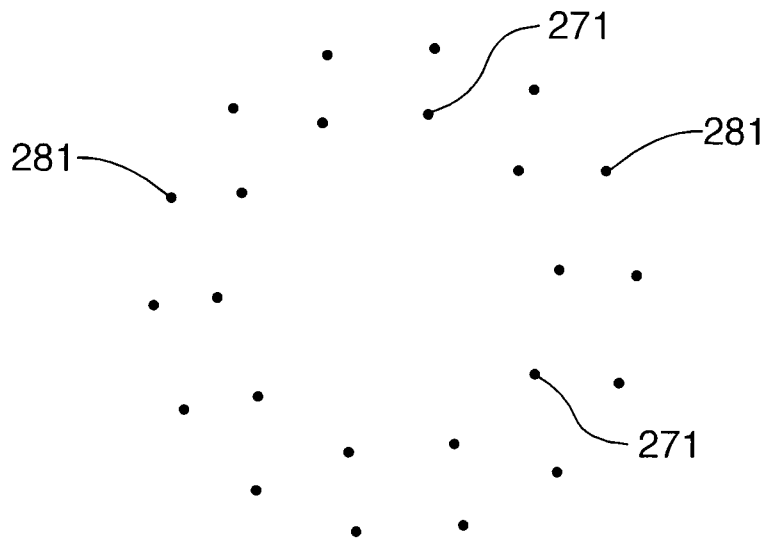

FIG.9B

16/29

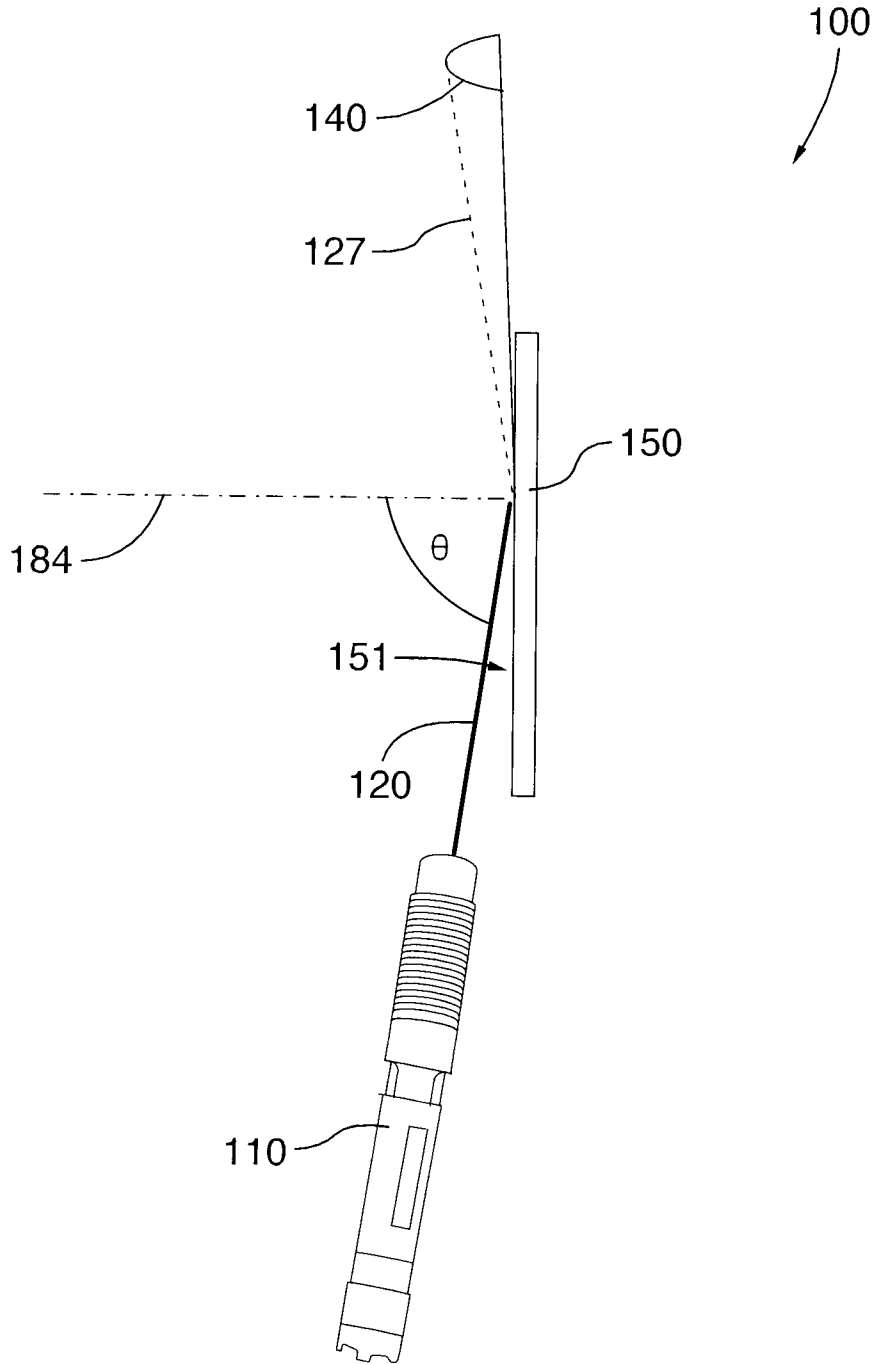

FIG.10A

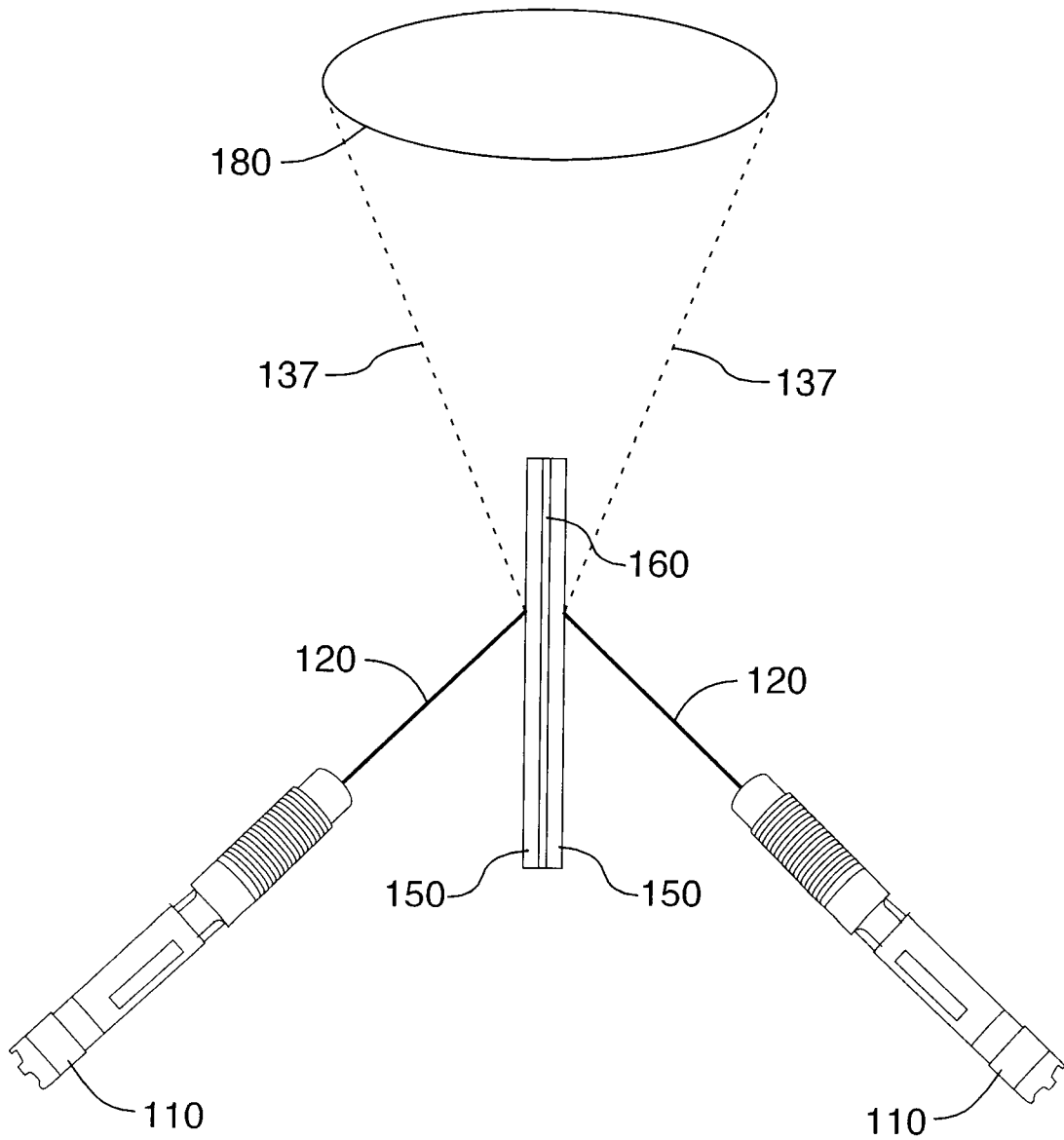

FIG.10B

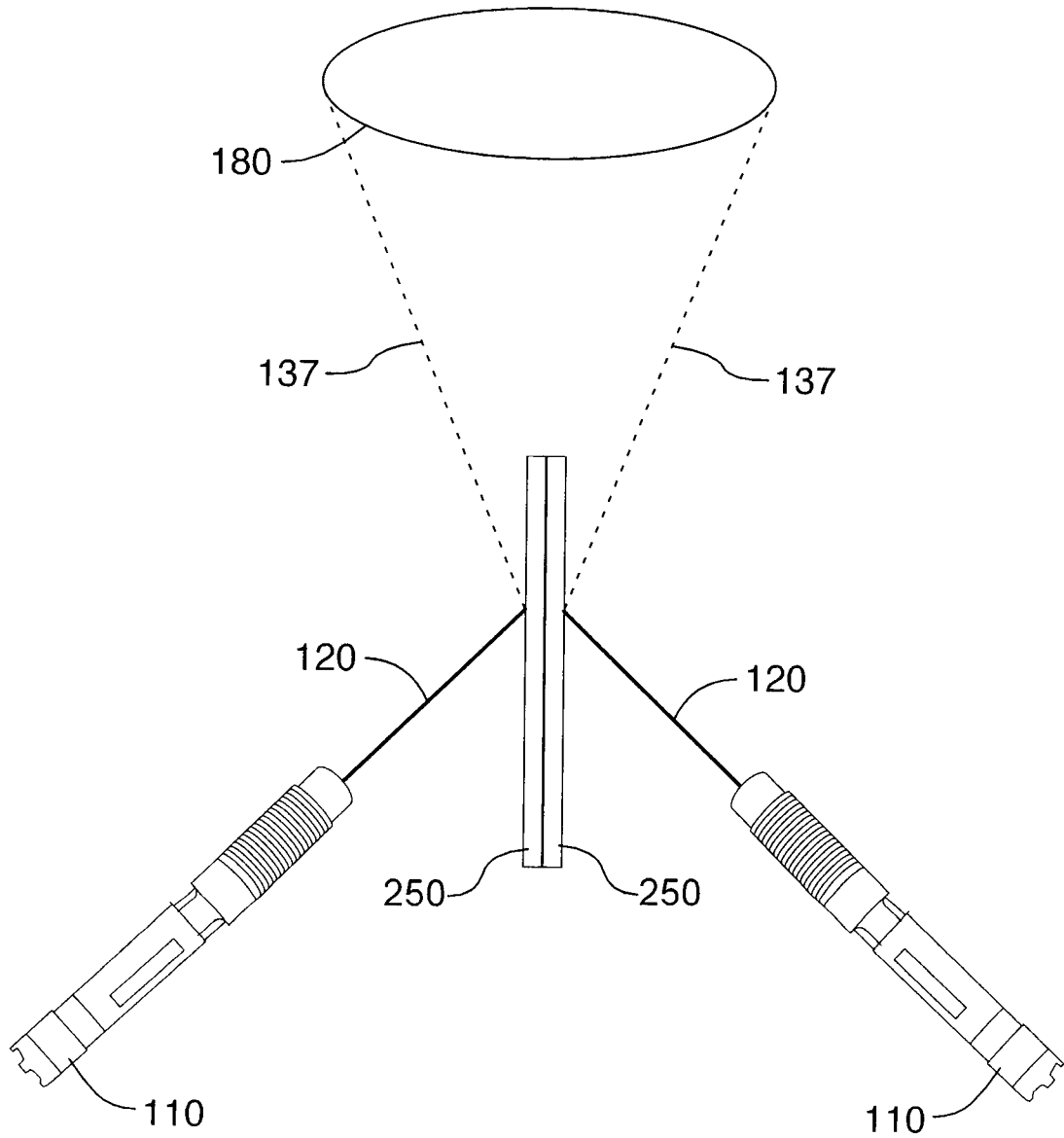

FIG.10C

19/29

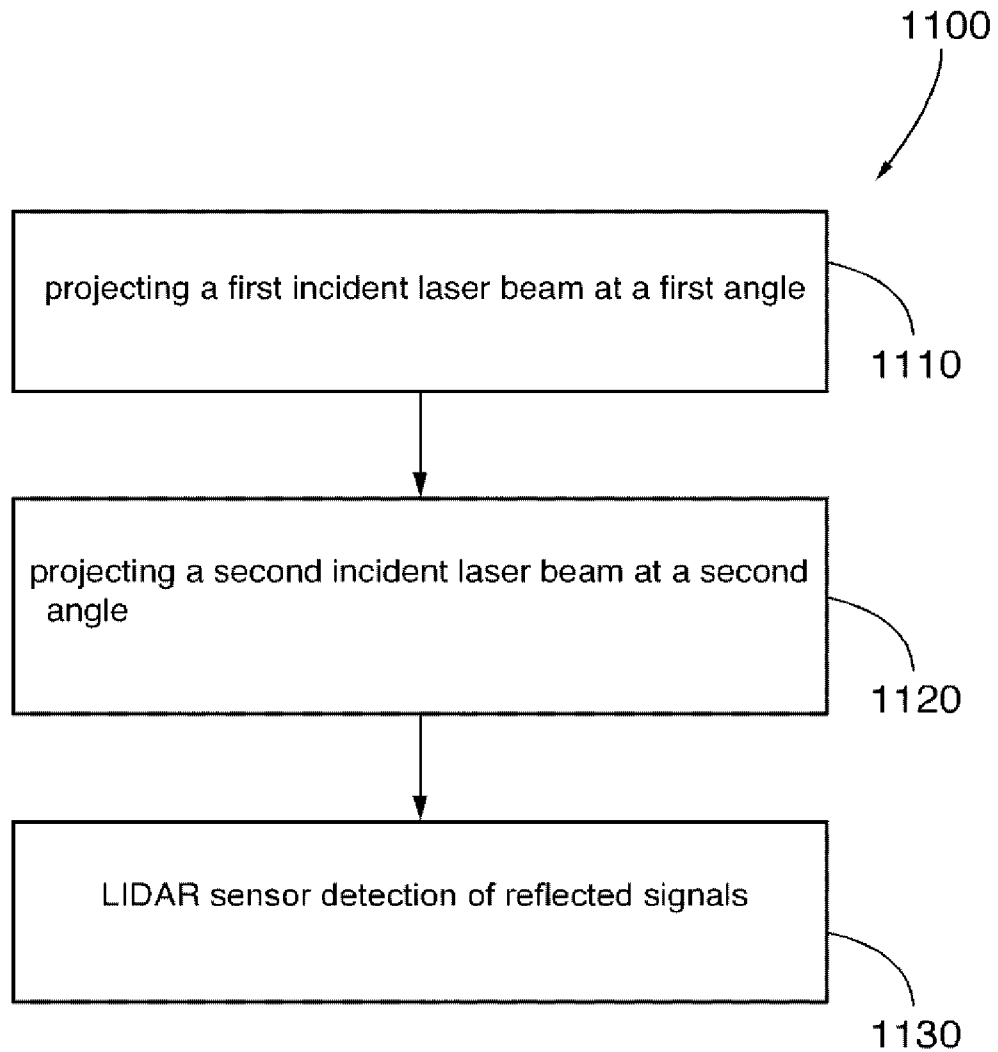

FIG.11

AMEND SHEET

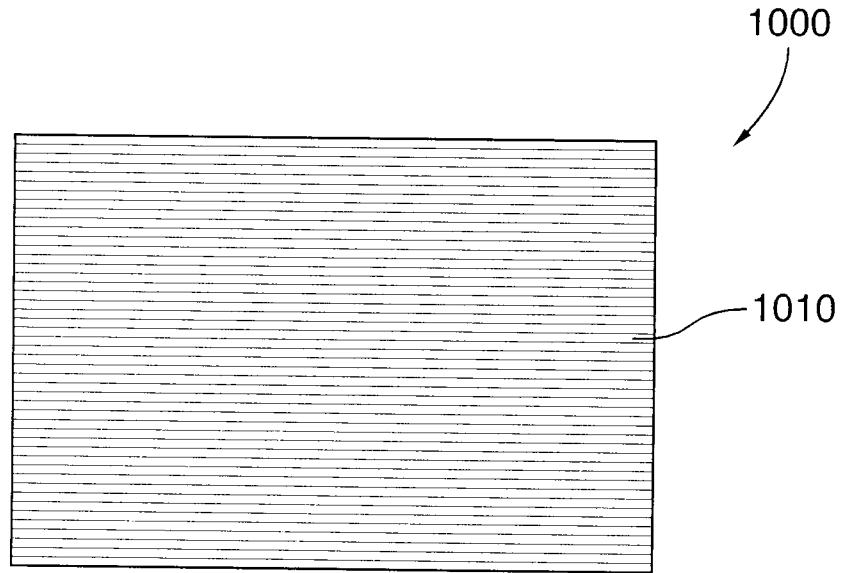

FIG. 12

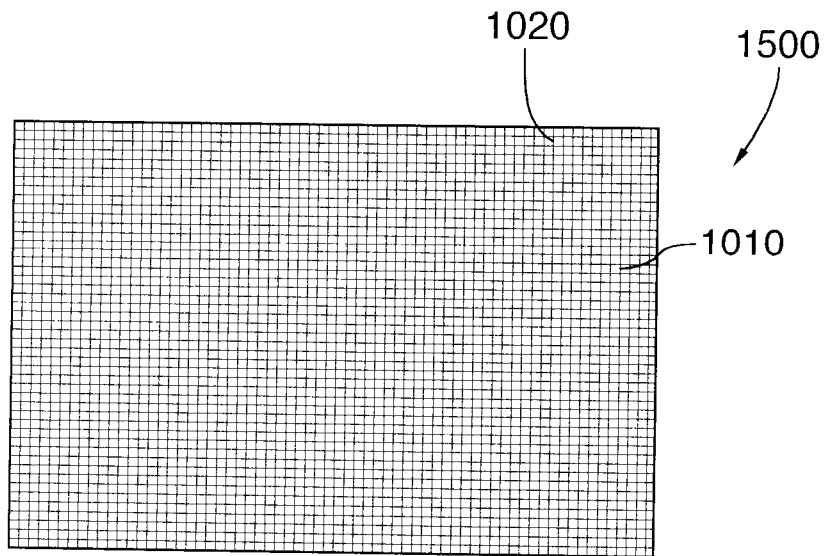

FIG. 13

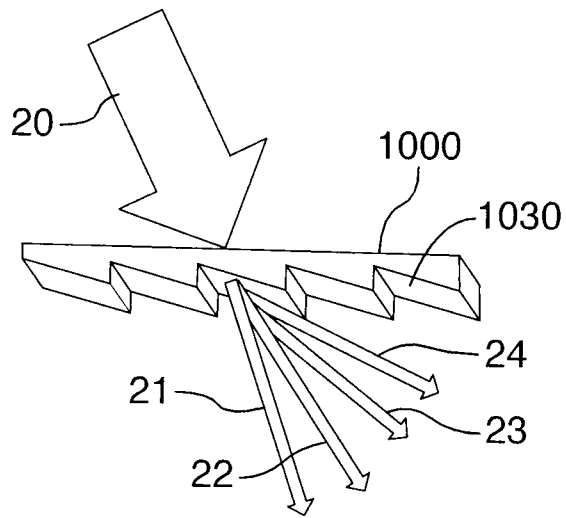

FIG.14

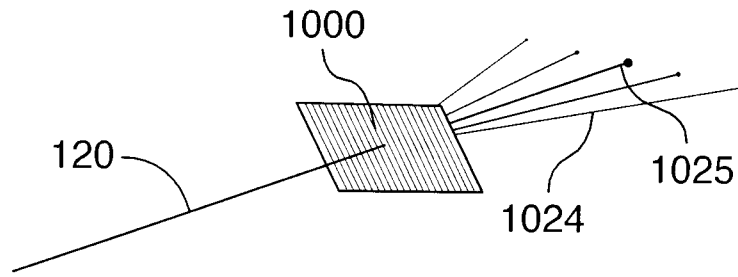

FIG. 15

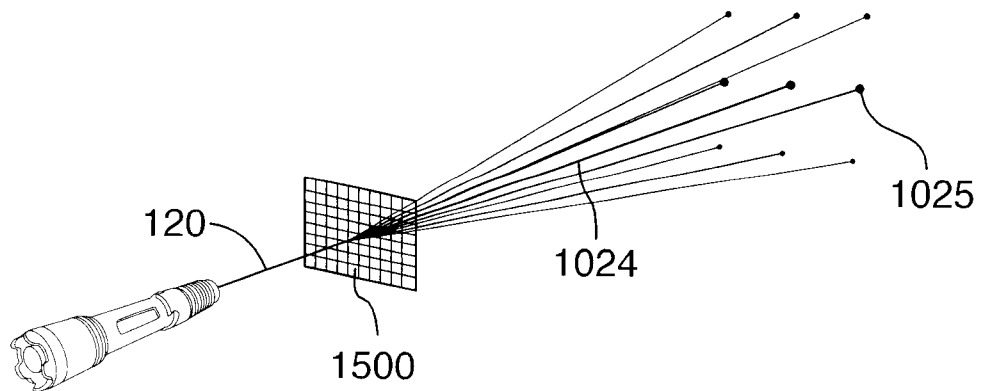

FIG. 16

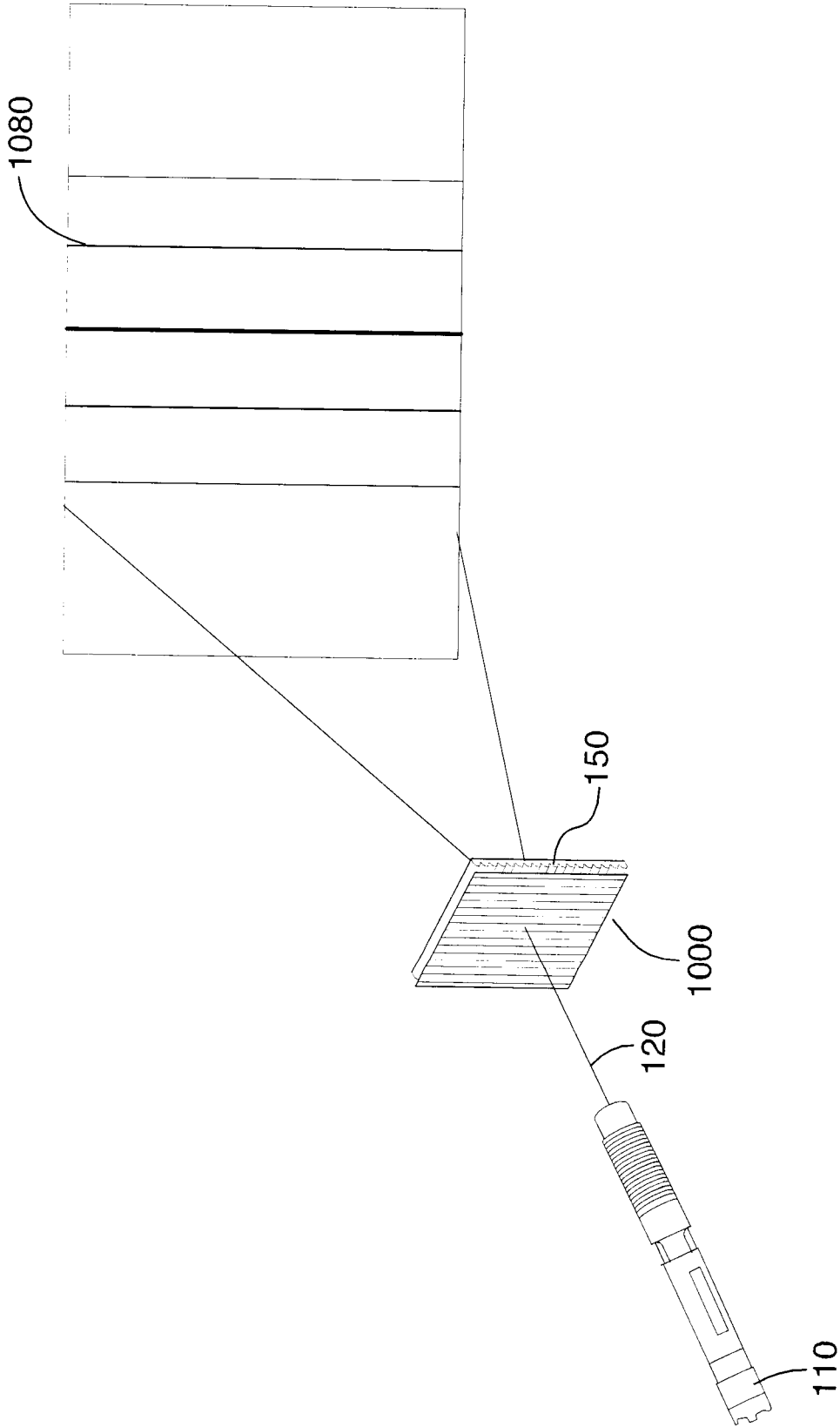

FIG.17

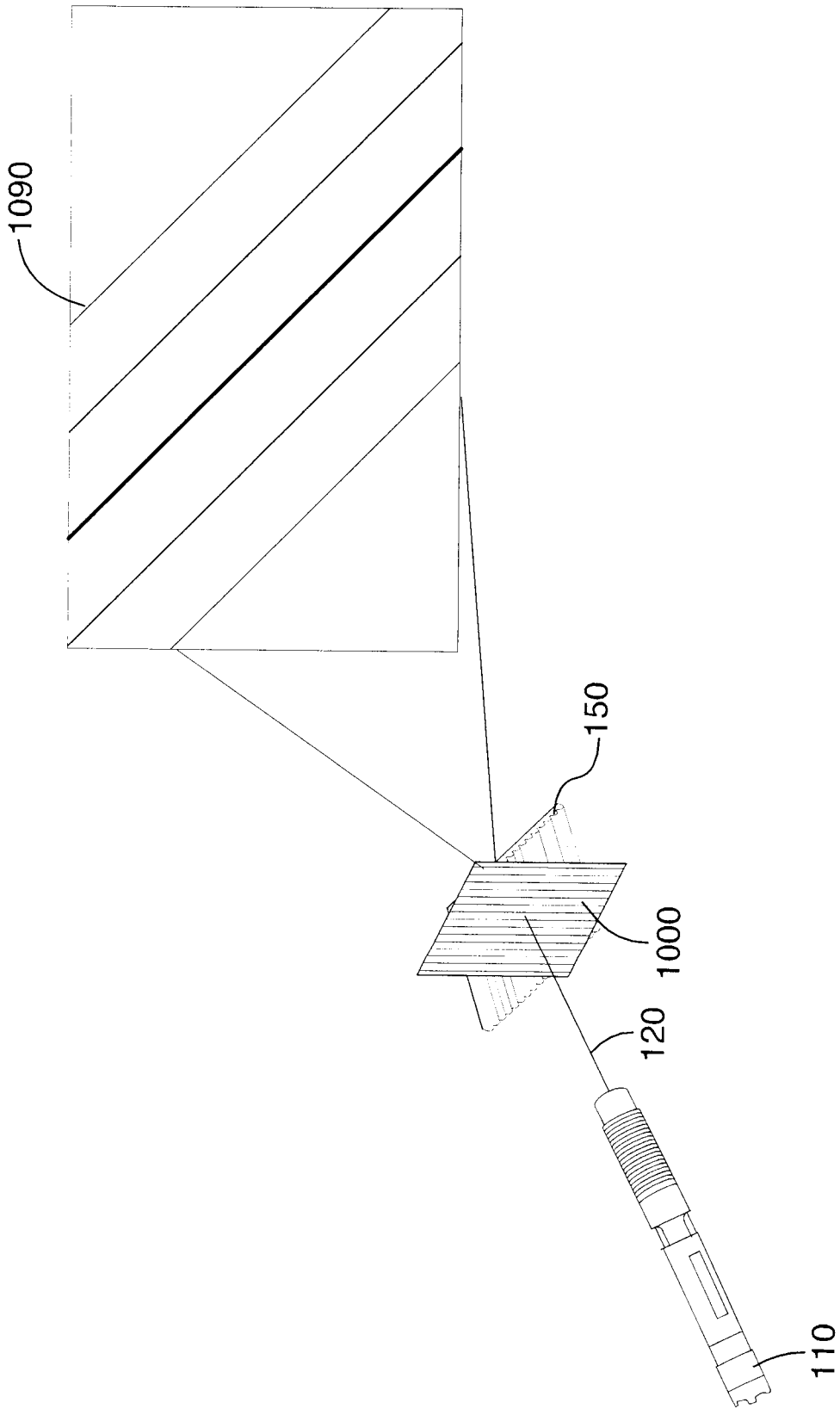

FIG.18

25/29

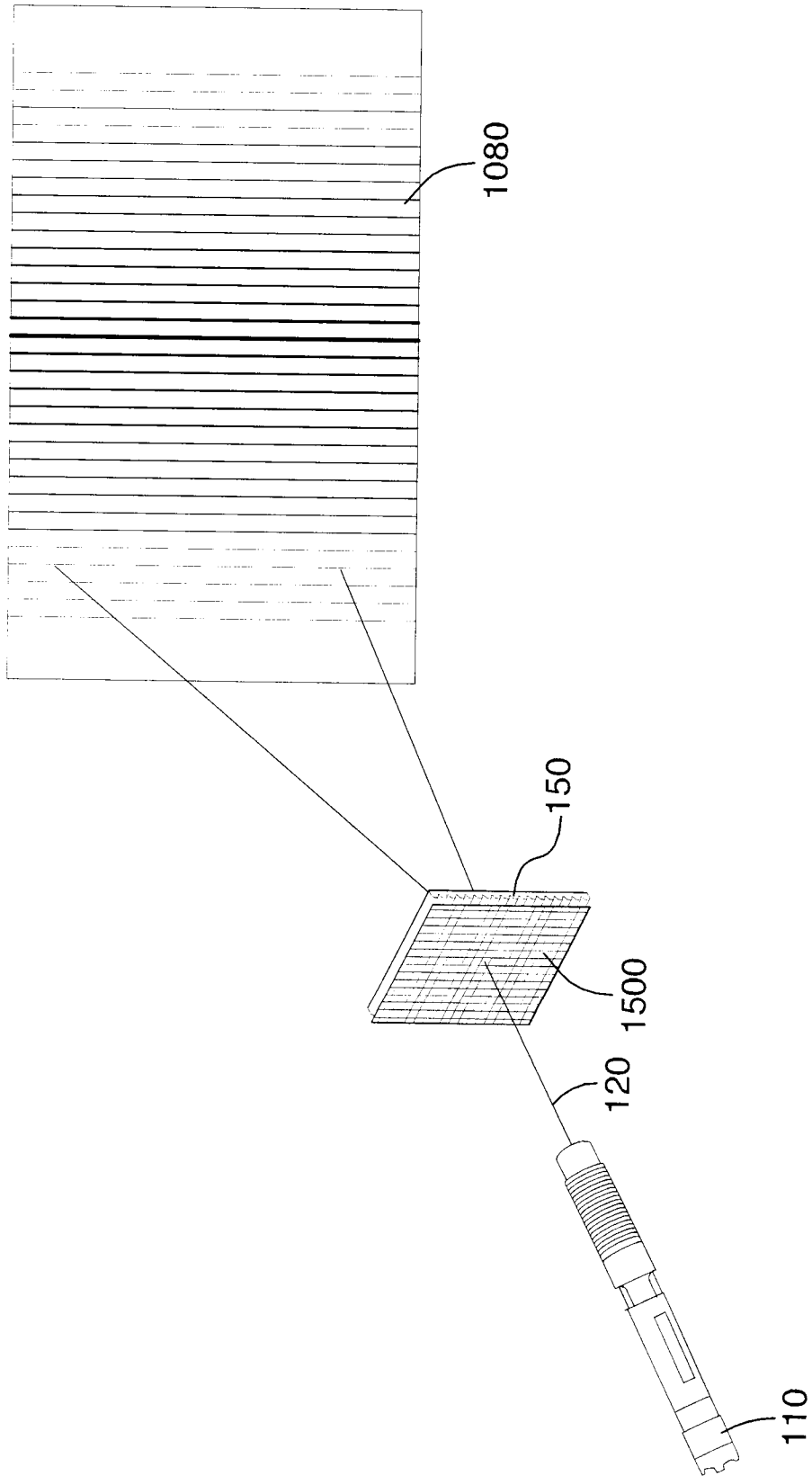

FIG.19

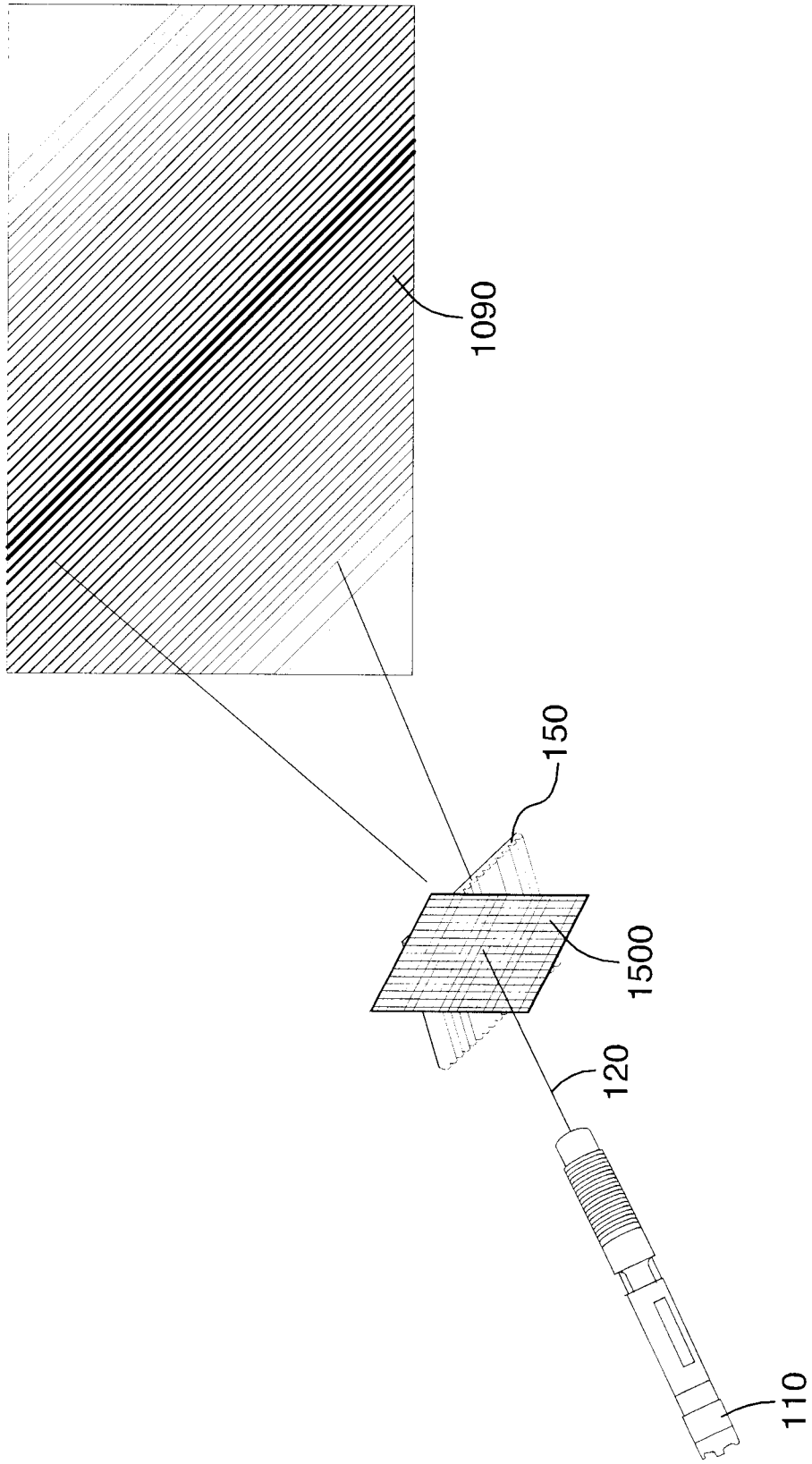

FIG. 20

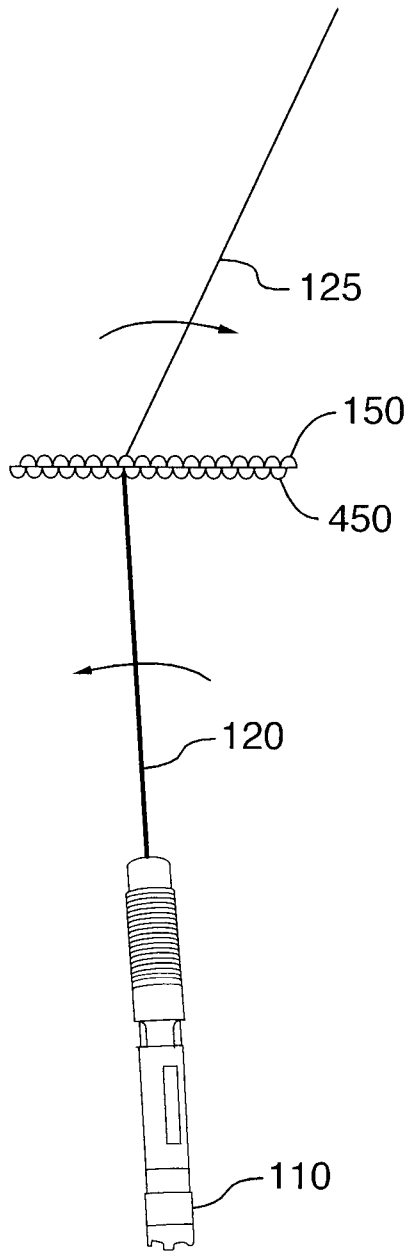

FIG.21

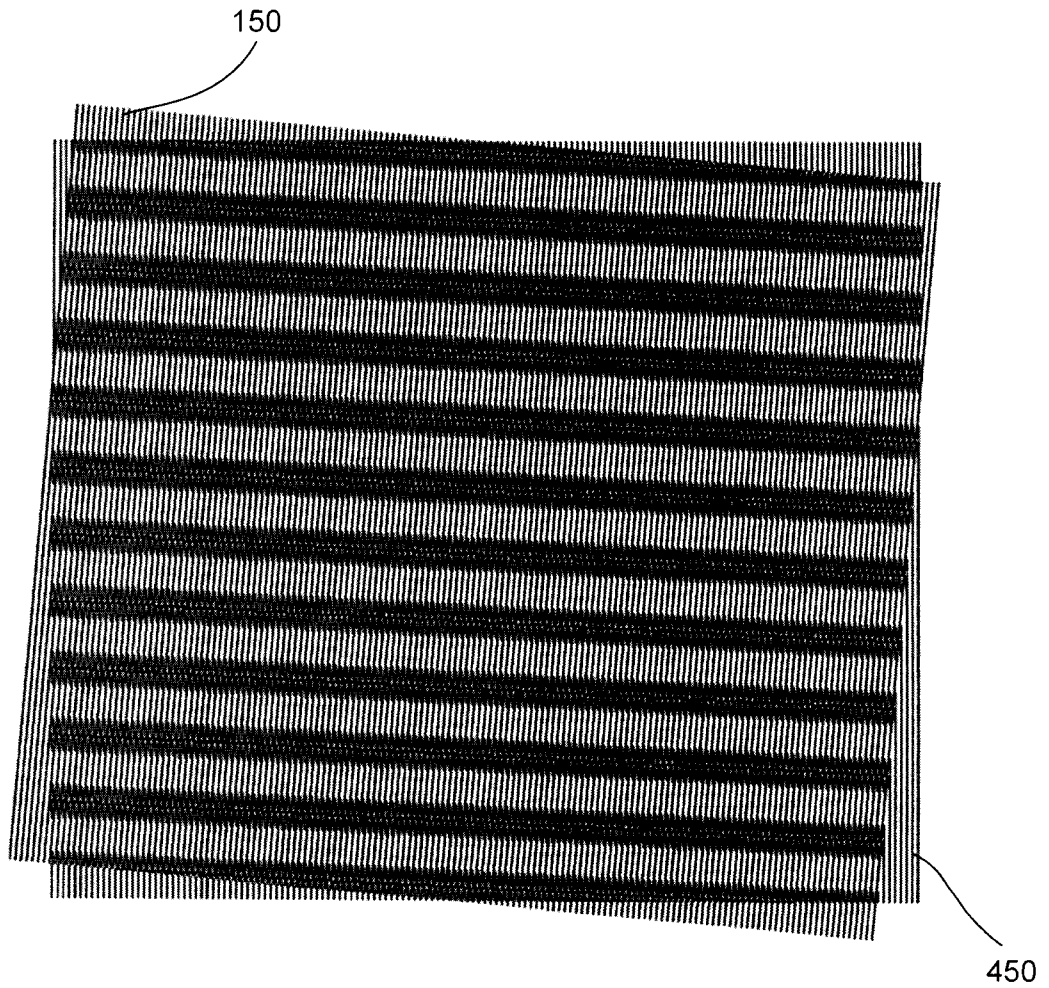

FIG. 22

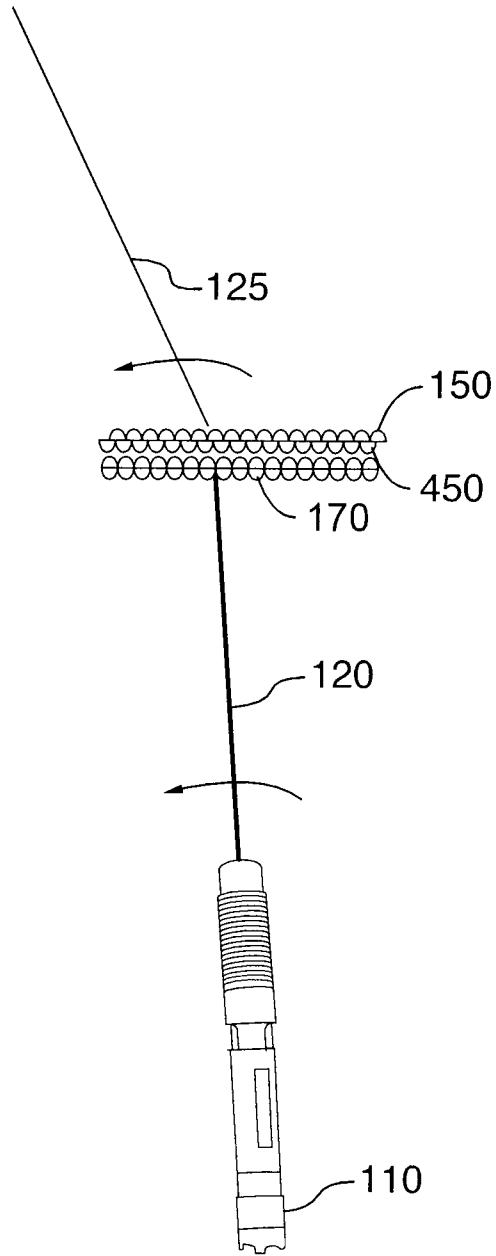

FIG.23

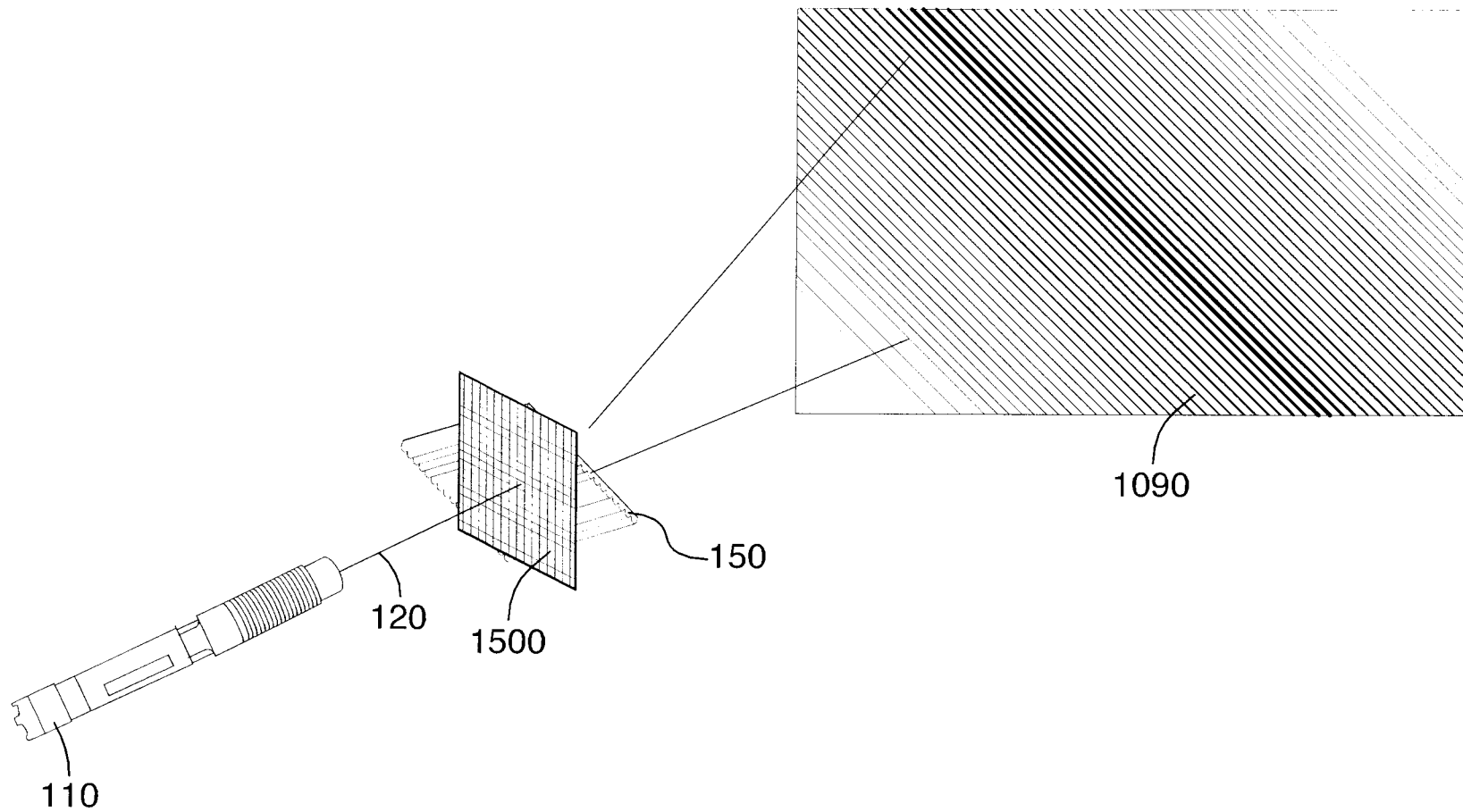

FIG.20