



- (51) International Patent Classification:
H01B 11/12 (2006.01)
- (21) International Application Number:
PCT/US2013/071045
- (22) International Filing Date:
20 November 2013 (20.11.2013)
- (25) Filing Language: English
- (26) Publication Language: English
- (30) Priority Data:
61/728,596 20 November 2012 (20.11.2012) US
- (72) Inventors; and
- (71) Applicants : COOK, William, Charles, II [US/US];
5087 Crany Road, Oceana, WV 24870 (US). SKAGGS,
Christopher, Scott [US/US]; 3149 Saturday Road, Victor,
WV 25938 (US). PRITT, Michael, Charles [US/US];
2835 Saturday Road, Victor, WV 25938 (US).
- (74) Agent: KENDRICK, Thomas, Y.; Benesch, Friedlander,
Coplan, & Aronoff, LLP, 41 S. High Street, Suite 2600,
Columbus, OH 43215 (US).
- (81) Designated States (unless otherwise indicated, for every
kind of national protection available): AE, AG, AL, AM,
AO, AT, AU, AZ, BA, BB, BG, BH, BN, BR, BW, BY,

BZ, CA, CH, CL, CN, CO, CR, CU, CZ, DE, DK, DM,
DO, DZ, EC, EE, EG, ES, FI, GB, GD, GE, GH, GM, GT,
HN, HR, HU, ID, IL, IN, IR, IS, JP, KE, KG, KN, KP, KR,
KZ, LA, LC, LK, LR, LS, LT, LU, LY, MA, MD, ME,
MG, MK, MN, MW, MX, MY, MZ, NA, NG, NI, NO, NZ,
OM, PA, PE, PG, PH, PL, PT, QA, RO, RS, RU, RW, SA,
SC, SD, SE, SG, SK, SL, SM, ST, SV, SY, TH, TJ, TM,
TN, TR, TT, TZ, UA, UG, US, UZ, VC, VN, ZA, ZM,
ZW.

- (84) Designated States (unless otherwise indicated, for every
kind of regional protection available): ARIPO (BW, GH,
GM, KE, LR, LS, MW, MZ, NA, RW, SD, SL, SZ, TZ,
UG, ZM, ZW), Eurasian (AM, AZ, BY, KG, KZ, RU, TJ,
TM), European (AL, AT, BE, BG, CH, CY, CZ, DE, DK,
EE, ES, FI, FR, GB, GR, HR, HU, IE, IS, IT, LT, LU, LV,
MC, MK, MT, NL, NO, PL, PT, RO, RS, SE, SI, SK, SM,
TR), OAPI (BF, BJ, CF, CG, CI, CM, GA, GN, GQ, GW,
KM, ML, MR, NE, SN, TD, TG).

Published:

- with international search report (Art. 21(3))
- before the expiration of the time limit for amending the
claims and to be republished in the event of receipt of
amendments (Rule 48.2(h))

(54) Title: SYSTEM AND METHOD FOR PROVIDING BROADBAND COMMUNICATIONS OVER POWER CABLING

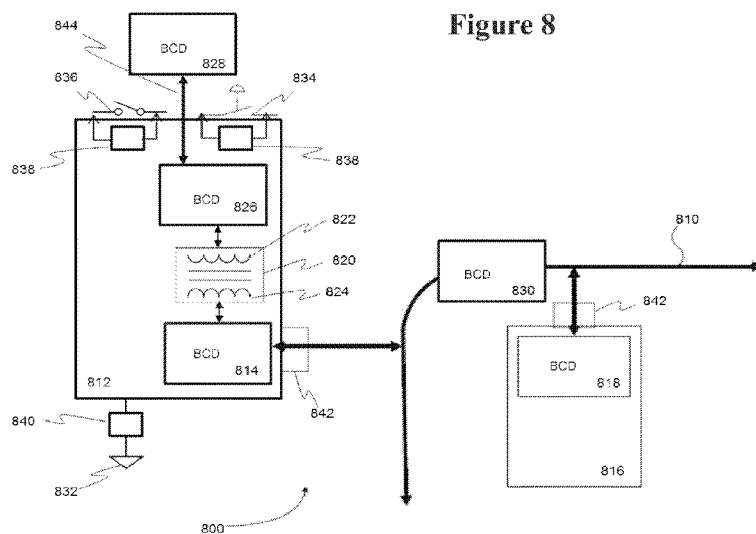

Figure 8

(57) Abstract: Systems and methods for providing broadband communication to and from locations in hostile environments, such as mines, pits, quarries, wells, boreholes, and rigs, for example, are disclosed. According to a first aspect of the present application, a system is disclosed for providing broadband communication via power cabling. The system may comprise one or more broadband communication devices for modulating, demodulating, reconditioning, repeating, transmitting, and receiving a signal via a power cable. The system may further comprise one or more broadband communication devices operatively connected to mining electrical distribution system components and mining equipment to provide broadband communication amongst the components, equipment, and other broadband communication devices within and outside the mine facility via the power cable.

WO 2014/081852 A1

**SYSTEM AND METHOD FOR PROVIDING BROADBAND
COMMUNICATIONS OVER POWER CABLING**

CROSS-REFERENCE TO RELATED APPLICATIONS

[0001] This application claims priority from U.S. Provisional Patent Application No. 61/728,596, filed on November 20, 2012, which is incorporated by reference herein in its entirety.

TECHNICAL FIELD

[0002] The present application generally relates to systems, devices, and methods for providing broadband communication to/from locations in hostile environments, such as mines, pits, quarries, wells, boreholes, and rigs for example. More specifically, the present application relates to a system and method for providing broadband communications over power cabling. The present application also describes devices that cooperate with existing high voltage and other cabling to enable distribution of broadband communications between a surface facility and facilities in hostile environments.

BACKGROUND

[0003] Certain methods and systems have previously been used for providing broadband communications to locations in hostile environments. Some such systems rely on wireless RF (“WiFi”) communications. Other such systems rely on fiber optic or other dedicated cabling.

[0004] Survivability in cases of disaster and the ability to operate for extended periods of time in harsh conditions are concerns for users of communications applications in hostile environments. Specifically, the dedicated cabling and the wireless communications hardware employed by current underground communications systems are easily damaged and are ill suited for long term use in adverse conditions.

[0005] Accordingly, there is a need for robust systems, methods and devices that enable broadband communications to, from, and between locations in hostile environments. Specifically, a need exists for a system providing broadband communications to locations in hostile environments that is durable and has superior survivability rates. A need further exists for a system for providing broadband communications to locations in hostile environments that utilizes existing hardware and cabling known to withstand harsh conditions.

SUMMARY

[0006] In one embodiment, an underground mining communication system is provided, the underground mining communication system comprising: a power center, the power center providing electrical energy via one or more electrical connections; one or more shielded mining power cables, the one or more shielded mining power cables operable to connect to the power center, one or more broadband communication device, and mining equipment; one or more frequency blocking devices; one or more broadband communication devices operable to at least one of modulate, demodulate, recondition, repeat, transmit, and receive communication signals via the one or more shielded mining power cables and further operable to communicate with another one or more broadband communication devices.

[0007] In another embodiment, an underground mining communication system is provided, the underground mining communication system comprising: a power distribution center, the power distribution center comprising: a substation, a switchgear, and one or more power center, the one or more power center comprising: one or more electrical energy input, one or more electrical energy output, one or more connection operatively connected to the one or more electrical energy output, one or more power distribution transformer, the one or more power distribution transformer operable to transfer an electrical energy from the one or more electrical energy input to the one or more energy output, wherein the one or more

power distribution transformer has a primary winding and a secondary winding, at least one signal path to ground, one or more emergency stop switches, one or more interlock switches, the power center further operable to provide the electrical energy via the one or more connection; one or more shielded mining power feeder cable, the one or more shielded mining power cable having one or more connection and operable to connect to at least one of: the one or more connection of the power center, one or more connection operatively connected to one or more broadband communication device, and one or more connection operatively connected to mining equipment; one or more trailing power cable, the one or more trailing power cable having one or more connection operable to connect to at least one of: the one or more connection of the power center, the one or more connection of the one or more broadband communication device, and the one or more mechanical connection of the mining equipment; one or more first frequency blocking device, the one or more first frequency blocking device passing frequencies in a range of 0 kHz - 5 kHz, wherein the first frequency blocking device is operatively connected to the signal path to ground of the power center, and wherein the first frequency blocking device is a low pass filter; one or more second frequency blocking device, the one or more second frequency blocking device passing frequencies over 100 kHz, wherein the one or more second frequency blocking device is operatively connected to at least one of: the one or more emergency stop switches of the power center, the one or more interlock switches of the power center, and wherein the one or more second frequency blocking device is a high pass filter; one or more first broadband communication device, the first broadband communication device operatively connected to the one or more shielded mining power feeder cable, the first broadband communication operable to at least one of modulate and demodulate signals, and transmit and receive signals via the one or more shielded mining power feeder cable; one or more second broadband communication device, the one or more second broadband communication device operatively

connected to the one or more shielded mining power feeder cable and the primary winding of the one or more power distribution transformer, the one or more second broadband communication device operable to at least one of modulate and demodulate signals, and transmit and receive signals via the one or more shielded mining power feeder cable; one or more third broadband communication device, the one or more third broadband communication device operatively connected to the secondary winding of the one or more power distribution transformer and least one of: the one or more shielded mining power feeder cable, and the one or more trailing power cable, the one or more third broadband communication device operable to at least one of modulate and demodulate signals, and transmit and receive signals via at least one of: the one or more shielded mining power feeder cable, and the one or more trailing power cable; one or more fourth broadband communication device operatively connected to at least one of: a fixed mining equipment, and a mobile mining equipment, and the one or more fourth broadband communication device further operatively connected to at least one of: the one or more shielded mining power feeder cable, and the one or more trailing power cable, the one or more fourth broadband communication device operable to at least one of modulate and demodulate signals, and transmit and receive signals via at least one of: the one or more shielded mining power feeder cable, and the one or more trailing power cable, such that the one or more fourth broadband communication device is operable to communicate with the one or more third broadband communication device via the at least one of: the one or more shielded mining power feeder cable, and the one or more trailing power cable; one or more fifth broadband communication device, the one or more fifth broadband communication device operatively connected to at least one of: the one or more shielded mining power feeder cable, and the one or more trailing power cable, the one or more fifth broadband communication device operable to at least one of modulate and demodulate signals, transmit signals, receive

signals, condition signals, and repeat signals via at least one of: the one or more shielded mining power feeder cable, and the one or more trailing power cable; a first element within the one or more broadband communication device for transmitting signals; and a second element within the one or more broadband communication device for receiving signals.

[0008] In another embodiment, a method for providing broadband communication over shielded power mine cabling in underground mines is provided, the method comprising: connecting at least a first broadband communication device to one or more shielded power mine cabling; connecting at least a second broadband communication device to a power center and the one or more shielded power mine cabling; connecting at least a third broadband communication device to a primary winding of a distribution transformer of the power center and the one or more shielded power mine cabling; connecting at least a fourth broadband communication device to a secondary winding of the distribution transformer of the power center and the one or more shielded power mine cabling; connecting at least a fifth broadband communication device to a high voltage mining equipment within an underground mine and the one or more shielded power mine cabling; generating a signal that will be transmitted by at least one of: a first broadband communication device, a second broadband communication device, a third broadband communication device, a fourth broadband communication device, and a fifth broadband communication device; modulating the generated signal to be transmitted over the one or more shielded power mine cabling; transmitting the modulated signal over the one or more shielded power mine cabling; preventing communication signal loss over the one or more shielded power mine cabling using a frequency blocking device; receiving the modulated signal at at least one of: the first broadband communication device, the second broadband communication device, the third broadband communication device, the fourth broadband communication device, and the fifth broadband communication device, the at least one receiving broadband communication

device different than the at least one transmitting broadband communication device; and demodulating the received signal, the demodulated signal to be further processed by the at least one receiving broadband communication device.

[0009] In another embodiment, a signal isolation ring is provided, the signal isolation ring comprising: a first signal isolation ring, the first signal isolation ring operatively connected to an inside of an equipment frame; a second signal isolation ring, the second signal isolation ring operatively connected to an outside of an equipment frame; and one or more electrical bushing between the first signal isolation ring and the second isolation ring; wherein the signal isolation ring is operable to prevent a signal to ground path via one or more mounting bolt of an electrical cable coupler.

BRIEF DESCRIPTION OF THE DRAWINGS

[0010] The accompanying figures, which are incorporated in and constitute a part of the specification, illustrate various example systems, devices, and methods, and are used merely to illustrate various example embodiments. It should be noted that various components depicted in the figures may not be drawn to scale, and that the various assemblies and designs depicted in the figures are presented for purposes of illustration only, and should not be considered in any way as limiting.

[0011] **Figure 1** illustrates an underground mining power distribution system.

[0012] **Figure 2** is a schematic block diagram illustrating an example environment.

[0013] **Figure 3** is a schematic block diagram illustrating an example broadband communication system.

[0014] **Figure 4** is a schematic block diagram illustrating an example system connecting a broadband communication device to a conductor.

[0015] **Figure 5** is a schematic block diagram illustrating an example coupling methodology.

[0016] **Figure 6** is a schematic block diagram illustrating an example point-to-point communication system.

[0017] **Figure 7** is a schematic block diagram illustrating an example communication network.

[0018] **Figure 8** is a schematic block diagram illustrating an example point-to-point communication network.

[0019] **Figure 9** is a schematic block diagram illustrating an example point-to-point communication network.

[0020] **Figure 10** is a schematic block diagrams illustrating a coupling methodology.

[0021] **Figure 11** is a schematic block diagrams illustrating a coupling methodology.

[0022] **Figure 12** is a schematic block diagrams illustrating a coupling methodology.

[0023] **Figure 13** is a schematic block diagrams illustrating a coupling methodology.

[0024] **Figure 14** illustrates one embodiment of a signal isolation ring.

DETAILED DESCRIPTION

[0025] Hostile environment worksites use power distribution systems to distribute electrical energy from a power grid or other energy source for use by systems in the worksite. One such hostile environment is a mine, illustrated in power distribution system **100** shown in **Figure 1**. Due to the nature of underground mining, underground mine power distribution systems **100** are almost always radial in structure. Such power distribution systems, and their specific components, are regulated by rule 30 CFR 75 of the Code of Federal Regulations. A general description of common mine power distribution systems are given in “Mine Power Systems” Information Circular 9258, herein incorporated by reference. As shown in **Figure 1**, components of a mine power distribution system include, among other things, a substation **108**, a switchhouse **110**, a power center **120**, cabling **130, 140, 150**, fixed mining equipment **160** and mobile mining equipment **170**, and distribution transformer **180**.

[0026] Possible embodiments of substation **108** typically include a main (or primary) substation, which transforms voltage levels from a utility company to a primary distribution voltage for the mine, and underground portable and unit substations that serve to transform the primary distribution voltage to a lower distribution voltage for use by mining loads and equipment **160** and **170**.

[0027] Switchhouse **110** may have a primary role including the providing of protective relaying in distribution system **100** and the allowance of branching of the radial distribution system.

[0028] Power center **120** and distribution transformers **180** may function as portable substations, transferring and converting the distribution voltage to utilization levels. As with switchhouse **110**, each of power center **120** and distribution transformer **180** have its own set of internal protection components such as emergency stop switches and interlock switches.

[0029] Cabling **130**, **140**, and **150** may be used to carry power and grounding between the various power equipment and eventually to mine loads and mining equipment **160** and **170**. Generally, cabling may be termed feeder cabling when part of the distribution system **100** and/or connected to fixed mining equipment **160** and trailing cabling when connected to portable/mobile mining equipment **170**. Fixed mining equipment **160** may include shops, pumps, or other equipment fixed at a particular location while mobile mining equipment **170** may include continuous miners, shuttle cars, bolters and other portable and mobile equipment.

[0030] This present application describes systems, devices and methods for providing broadband communications to and within an underground location. Specifically, the present application describes systems and methods for utilizing shielded power cabling to transmit

broadband communications to, from, and within locations in hostile environments, such as mines, pits and quarries, tunnels, wells, boreholes, and rigs for example.

[0031] The systems, devices, and methods described herein advantageously supply broadband communications to, from, and within hostile environment such as the underground workings of a mine, pit, quarry, tunnel, well, borehole, and rig, for example, via existing or new high-voltage cabling, such as MPF-GGC, MP-GC, G-GC, W-type cabling, submarine cabling, and any other cabling commonly known in mining, drilling, mineral extract, and other applicable arts as will be known to the ordinary artisan. Such communications provide the capability to transmit information from processes and/or machines, as well as voice and/or video to and from external facilities, point to multipoint and/or point to point within the underground workings. The high-voltage power cabling currently available for mining and other harsh underground environments may be used to provide a robust communication medium as disclosed in association with one or more embodiments of the present invention. Such cabling may be a substantially stationary cable (for example, cables **130**, cables **140**, and the cables **150** connecting equipment **160**) or mobile cable (for example, cables **150** connecting equipment **170**) and may be a shielded or unshielded cable depending on the application as would be known to one of ordinary skill in the art. The mobile cables often termed “trailing cables” are typically used to connect and power mobile equipment.

[0032] The present application describes systems, devices, and methods that enable high speed data communication via existing or new high voltage feeder cabling or trailing cabling. Information from, for example, fixed or mobile mining equipment may be aggregated at power center(s) **120** located throughout the facility or site. The information may then be communicated over the relevant power cabling (i.e., **130**, **140**, and/or **150**) to the surface facility for use or distribution to other personnel or facilities around the world via the internet or other dedicated networks or communication systems.

[0033] With reference to **Figure 1**, hostile environment worksites use power distribution systems **100** to distribute electrical energy from a power grid or other energy source for use by systems in the worksite. A power distribution system **100** may include electrical substation **108** to transform a voltage from power grid or other energy source for use by systems in the worksite. Power distribution system **100** may also include a switchgear or switchhouse **110**, which may include electrical disconnects, fuses or circuit breakers to isolate, protect, and control electrical circuits and equipment. Power distribution system **100** may also include one or more power centers **120**. Power centers **120** may be a portable or stationary device operable to take an input voltage or input electrical energy and transfer the input voltage or input electrical energy to one or more output voltage or output electrical energy. Power centers **120** may use one or more power distribution transformers **180** having a primary winding and a secondary winding to transfer input voltage and input electrical energy to output voltage and output electrical energy. In one embodiment, one or more power distribution transformers **180** are housed within power centers **120**, though power distribution transformers **180** are not limited to being housed within power centers **120** and may be located in other parts of power distribution system **100**. Power distribution transformers **180** may at least one of: isolate input voltage and input electrical energy from output voltage and output electrical energy, step up input voltage and input electrical energy such that output voltage and output electrical energy is greater than input voltage and input electrical energy, and step down input voltage and input electrical energy such that output voltage and output electrical energy is less than input voltage and input electrical energy. Power center **120** may also include one or more mechanical connections (not shown), however power center is not limited to mechanical connections and may include electrical or magnetic couplings such as inductive or capacitive couplings. Other embodiments will be known to those of ordinary skill in the art. Power center mechanical connections may

interface with power cabling connections such that power cabling **130**, **140**, and **150** may operatively connect to power center **120** to transfer an input voltage and input energy to power center **120**, and transfer an output voltage or output energy from power center **120** for use by worksite systems **160** and **170**. Power center **120** also includes standard electrical safety features, including for example: a plurality of emergency stop switches, a plurality of interlock switches, and a ground conductor or signal path to ground (not shown).

[0034] Using the systems, devices and methods of the present application, high-speed broadband communications, including data, video and/or voice, via a broadband communication signal such as a Broadband over Powerline (“BPL”) signal or a Digital Subscriber Loop (“DSL”) signal, may be transmitted to all or selected mobile and/or stationary equipment or processes located in all or selected locations of underground workings of a mine, tunnel, pit, quarry, well, borehole, and rig. Such communication may be accomplished by connecting phase wire(s), ground wire(s) and/or ground check wire(s) to a broadband communication modem or other broadband communication device either directly, capacitively, or inductively coupled.

[0035] In some embodiments, broadband communication devices, such as BPL and DSL devices, may be connected with an amplifier, boards, or additional circuitry and/or with an impedance matching network. In some embodiments, an impedance matching network may be a manually tuned or set device or may be completely automated with a computer, microcontroller, or other embedded device capable of detecting and tuning impedance of impedance matching network. Impedance matching network may also monitor and/or adjust a signal. Impedance matching network may also monitor and/or adjust a signal to noise ratio (“SNR”).

[0036] Broadband communication systems may be capable of repeating signals as desired to extend the transmission distance using any of several techniques. For example,

transmission distances may be extended using broadband communication devices with repeating functionality. Alternatively, converting the transmitted signal to another medium, such as standard Ethernet, wireless/wired RF or fiber for transmission may extend transmission distance. Further, transmission distance may be extended by retransmitting a signal over another set of broadband communication devices using a point-to-point methodology. In another embodiment, one or more standalone repeaters or like electrical devices may be used by broadband communication system to repeat signals and extend signal transmission distances. Other methods of reducing attenuation of the transmitted signals will be known to those of ordinary skill in the art and fall within the scope of the present invention.

[0037] Systems according to an embodiment of the present application comprise broadband communication devices that may reside at predetermined locations throughout a worksite. Broadband communication devices may reside in power centers, belt starters, disconnects, pumps, couplers, and mobile equipment, but are not limited to these locations and may reside in other locations throughout a worksite as needed to accomplish a desired communication. In other embodiments, broadband communication devices may also reside above ground or away from a hostile worksite and be connected to other broadband communication devices in a hostile worksite. In some embodiments, broadband communication systems may use technology that allow repeating signals to be transmitted from one broadband communication device to be received by another broadband communication device. Further, such broadband communication systems may employ point-to-point, mesh or other methods of communications between broadband communication devices.

[0038] In embodiments using point-to-point methods, data may be processed and/or collected on a local Ethernet network and then transported via another set of broadband

communication devices, or another communication medium, to another location for processing, storage, and usage. The broadband communication devices may be directly connected or coupled to ground, neutral, ground check, or phase conductors of the power cable on the high voltage distribution system.

[0039] In one embodiment, an impedance matching circuit or device may be installed at a point where a broadband communication device attaches to power cabling to compensate for impedance mismatches. An impedance matching network may be setup to be either manually or automatically “tuned” to provide for best transmission scenarios.

[0040] Each broadband communication device may interface to an Ethernet or other data communication network and transport data over power cabling. Serial devices may be converted to Ethernet to allow transmission either by an external convertor or directly converted by the broadband communication device. In some embodiments, broadband communication devices may comprise modems. Modems, which are not protocol dependent, may modulate any protocols or data to broadband communication device signals. Modems may also demodulate any broadband communication device signals to protocols or data. In some embodiments, broadband communication devices may also comprise a battery, an uninterruptable power supply, a capacitor or some other energy storing device to provide power to broadband communication devices and allow for communications during power outages.

[0041] Referring now to **Figure 2**, there is illustrated an example environment **200**. Example environment **200** is a mining environment comprising a surface or above-ground portion **210** and an underground portion **220**. Surface portion **210** comprises a surface device **212** that receives power from a power source such as a public utility electric grid and transmits power to equipment in the underground portion **220** via power cabling **214**. Surface device **212** may be a substation or power center.

[0042] Equipment in underground portion 220 comprises underground devices 222, 226, 228, and 229 as well as couplers 224 and 227. Couplers 224 and 227 may comprise electric couplers that connect stretches of high voltage cables underground. In one embodiment, couplers 224 and 227 comprise integrated broadband communication devices that act as and/or comprise modems, repeaters, filters, frequency blocking devices, signal monitors/adjusters, SNR monitors/adjusters, line conditioners, and data collection devices, such that integrated broadband communication devices may: modulate and demodulate signals, amplify a signal for further transmission over power cabling, attenuate and pass signals of certain frequencies, monitor and adjust signals, monitor and adjust SNR over power cabling, deliver a voltage at proper level and characteristics to run worksite equipment properly, collect and store data, and perform other such functions associated with such devices.

[0043] In one embodiment, couplers 224 and 227 are mechanical coupling devices that provide at least one of: a connection between power cables, a connection between power cables and worksite equipment, and a connection between power cables and broadband communication devices. In one embodiment, couplers 224 and 227 include connectors, potheads, terminators and like devices. In another embodiment, couplers 224 and 227 include magnetic or electrical coupling devices that allow for inductive and capacitive coupling. Couplers 224 and 227 may couple to a metal frame of worksite equipment (not shown) and interface with connections on worksite equipment (not shown) to provide an electrical energy to worksite equipment.

[0044] In one embodiment, worksite equipment 222, 226, 228, and 229 may comprise any of a number of stationary or mobile underground devices having an integrated or associated broadband communication device for communicating data over underground

power cabling. The example devices and example connection methodologies are described with reference to **Figures 3-14** below.

[0045] Referring now to **Figure 3**, there is illustrated a first example system **300** for transmitting broadband communication signals. System **300** is a signal isolation system that comprises a shielded power cable **310** comprising a shielded conductor **320**. System **300** further comprises two broadband communication devices **316** and **318** connected to shielded conductor **320**. Shielded conductor **320** may provide a broadband communication path between broadband communication devices **316** and **318**.

[0046] As illustrated, frequency blocking device **312** and **314** are installed on the shielded power cable **310** outside of either end of the communication path between broadband communication devices **316** and **318**. Frequency blocking devices **312** and **314** may prevent or block signals from being attenuated by multipaths. Frequency blocking devices **312** and **314** may further prevent broadband devices **316** and **318** from communicating with other broadband communication devices that may utilize other portions of shielded power cable **310** to transmit broadband communications. In another embodiment, frequency blocking devices **312** and **314** may prevent at least one of: crosstalk, noise, capacitive coupling, inductive coupling, and conductive coupling, on all or part of power cable **310** in system **300**.

[0047] Frequency blocking devices **312** and **314** may also prevent or mitigate signal interference from other broadband communication devices (not shown) that may utilize other portions of shielded power cable **310**. Frequency blocking devices **312** and **314** may thereby create a single point-to-point communication path for signals between broadband communication devices **316** and **318**. In one embodiment, frequency blocking devices **312** and **314** comprise a ferrite core, bead, or similar device tuned to block certain signal frequencies.

[0048] With respect to mine electrical distribution system **100** illustrated in **Figure 1**, the mine may benefit from this embodiment, for example, by utilizing one or more instances of the embodiment in one or more locations of cables **130**, **140**, and/or **150** or power center **120** and distribution transformer **180** and/or switchhouse **110**.

[0049] Referring now to **Figure 4**, there is illustrated an example system **400** for connecting a broadband communication device **410** to a conductor **414**. As illustrated, broadband communication device **410** may be connected to conductor **414** via a filter **412**. Filter **412** may comprise a device or circuit for tuning, filtering, and impedance matching. Filter **412** may comprise passive components such as resistor(s), capacitor(s), and inductor(s) as required. Filter **412** may be manually set up and/or tuned. Alternatively, filter **412** may be configured to automatically adjust using a microcontroller- or microprocessor-based control system. In one embodiment, filter **412** may be any one of a: high pass filter (HPF), a low pass filter (LPF), and a band-pass filter (BPF). Filter **412** may be selected based on a frequency to be filtered. For example in one embodiment filter **412** is a high pass filter passing 100 kHz and above.

[0050] Although a single lead is illustrated, filter **412** may accommodate multiple leads from broadband communication device **410**, and filter **412** may also accommodate connection to multiple conductors, such as conductor **414**. Further, filter **412** may be integrated into broadband communication device **410**. Filter placement on the system may vary for purposes of impedance matching and other system design considerations.

[0051] With respect to mine electrical distribution system **100** illustrated in **Figure 1**, the mine may benefit from this embodiment for example by utilizing one or more instances of the embodiment in one or more locations on cables **130**, **140**, and/or **150**.

[0052] Referring now to **Figure 5**, there is illustrated an example coupling methodology **500**. As illustrated, a single broadband communication device **510** may be

connected to multiple power cables **512** and **514** in a system for communicating to and from hostile locations such as underground locations using, in one embodiment, BPL. In one embodiment, power cables **512** and **514** are a shielded high voltage power cable, such as an MPF-GGC three-conductor mine power cable. In another embodiment, power cables **512** and **514** are any one of or a combination of: MP-GC, G-GC, Type W, DLO, submarine cables, and any like power cabling used in hostile environments. Broadband communication device **510** may be connected to one or more phase, ground or ground check conductors of two different cables. Of course, in alternate embodiments, frequency blocking devices and filters described above may be employed to improve performance.

[0053] Referring now to **Figure 6**, there is illustrated an example point-to-point communication system **600** for providing broadband communication over mine power cabling. As shown, system **600** comprises a mine power cable **610** connecting two broadband communication devices **612** and **614**. Optionally, system **600** may further include one or more frequency blocking devices, such as frequency blocking devices **624** and **626**. Broadband communication devices **612** and **614** are connected to communication devices **616** and **618**, respectively, to facilitate broadband communications between the communication devices. Broadband communication devices **612** and **614** may be connected to communication devices **616** and **618**, respectively, by communication lines **620** and **622**. Communication lines **620** and **622** may be Ethernet, serial, fiber optic, or other type of communication line as desired to be compatible with both the communication device and the broadband communication device.

[0054] With respect to the mine electrical distribution system **100** illustrated in **Figure 1**, the mine may benefit from this embodiment for example by utilizing one or more instances of the embodiment in one or more of the locations on power center **120** and distribution transformer **180**.

[0055] Multiple broadband communication devices may be disposed at various locations along a mine power cabling to facilitate communications between and among any and all of the broadband communication devices. An example communication system **700** is illustrated in **Figure 7**. System **700** comprises a plurality of broadband communication devices **712**, **714**, and **716** connected to one another via power cable **710**. System **700** may be configured to enable each broadband communication device **712**, **714** and **716** to communicate with another or several other broadband communication devices. Further, each broadband communication device **712**, **714** and **716** may be configured to operate as a repeater to improve reliability and performance of system **700**. With respect to mine electrical distribution system **100** illustrated in **Figure 1**, the mine may benefit from this embodiment for example by utilizing one or more instances of the embodiment in one or more locations on cables **130**, **140**, and/or power center **120**.

[0056] **Figure 8** illustrates an example point-to-point network **800** comprising a power center **812** and worksite equipment **816** communicating via broadband over a power cable **810**. Power center **812** includes a power distribution transformer **820** with a primary winding **822** and a secondary winding **824**. Power center **812** and worksite equipment **816** may be coupled to power cable **810** in any of the ways described above with reference to broadband communication devices. In one embodiment, power center **812** and worksite equipment **816** are coupled to power cable **810** via couplers **842** on a metal frame of power center **812** and worksite equipment **816**. Broadband communication device **826** may be coupled to primary winding **822** of power distribution transformer **820** within power center **812**. Broadband communication device **814** may be coupled to secondary winding **824** of power distribution transformer **820** within power center **812**. Broadband communication device **828** may be operatively connected to power cable **844** also in connection with power center **812**. Broadband communication device **830** may be operatively connected to power

cable **810** and may be used as a repeater or signal conditioner to amplify, retransmit, or condition signals sent over cable **810**.

[0057] In some embodiments, power center **812** may be a belt starter or similar voltage distribution point. Worksite equipment **816** may be stationary, such as pumps, motors, and battery chargers, or mobile, such as continuous miners, shuttle cars, drag lines, and electric trucks. Data, voice, and/or video may be transmitted between power center **812** and worksite equipment **816** and further transmitted to broadband communication device **828** to be sent elsewhere in system **800**. Information transmitted between power center **812** and worksite equipment **816** may be stored at either or both devices. Alternatively, information may be transmitted/repeated on to another location via broadband communication devices **830** and **828**, fiber optic, or any other communication method. Power center **812** further comprises signal path to ground **832**, emergency stop switch **834**, and interlock switch **836**. Additionally, power center **812** may include high pass filter **838** across emergency stop switch **834** and interlock switch **836** and low pass filter **840** operatively connected to ground path **832**.

[0058] With respect to mine electrical distribution system **100** illustrated in **Figure 1**, the mine may benefit from this embodiment, for example, by utilizing one or more instances of the embodiment in one or more of the locations of power center **120**, equipment **170**, and distribution transformer **180**.

[0059] **Figure 9** illustrates an example point-to-point network **900** where each node comprises a distribution point for other devices. Specifically, **Figure 9** illustrates a power cable **910** which enables broadband communications between distribution point **912** and distribution point **916**. Each distribution point **912** and **916** comprises a broadband communication device **914** and **918**, respectively to enable broadband communications. Each

distribution point may be connected to and/or communicate with other devices that are not directly connected to power cable **910**.

[0060] Data, voice and/or video may be transmitted between distribution points **912** and **916**. Information transmitted between distribution points **912** and **916** may be stored at either or both devices. Alternatively, information may be transmitted/repeated on to another location via BPL, DSL, fiber optic, or any other communication method.

[0061] With respect to mine electrical distribution system **100** illustrated in **Figure 1**, the mine may benefit from this embodiment, for example, by utilizing one or more instances of the embodiment in one or more of the locations of power center **120** and distribution transformer **180**.

[0062] **Figures 10-13** illustrate several example coupling methodologies to connect a broadband communication device to a shielded high-voltage power cable. **Figure 10** illustrates a direct connect methodology **1000**. Broadband communication device **1010** is directly connected to conductors within shielded cable **1020**. The conductors may be individual or paired phase, ground, ground check conductors, or any other conductive path within cable **1010**.

[0063] **Figure 11** illustrates an inductive or capacitive coupling methodology **1100**. Broadband communication device **1110** is connected to conductors within shielded cable **1120** using inductive or capacitive coupling devices **1112** and **1114**. The conductors may be individual or paired phase, ground, ground check conductors, or any other conductive path within cable **1010**.

[0064] **Figure 12** illustrates a filtered or tuned coupling methodology **1200**. Broadband communication device **1210** is connected to conductors within shielded cable **1220** using filters **1212** and **1214**. The conductors may be individual or paired phase, ground, ground check conductors, or any other conductive path within cable **1210**. Each filter **1212**

and **1214** comprises a tuning circuit and may be manually or automatically tuned for impedance matching or impedance changing capabilities. Each filter **1212** and **1214** may also monitor and/or adjust a signal. Each filter **1212** and **1214** may further monitor and adjust a SNR.

[0065] **Figure 13** illustrates a common ground coupling methodology **1300**. A first lead of broadband communication device **1310** is connected to a conductor within shielded cable **1320** and a second lead of broadband communication device **1310** is connected to a common ground, such as a mine roof support system. Although direct connections are illustrated in **Figure 13**, other connection techniques may be employed. The first lead may be connected to an individual or paired phase, ground, ground check conductors, or any other conductive path within cable **1310**.

[0066] Signal paths to ground inherent in power distribution systems degrade communication signals. For example when using a ground wire as a communication path, the signal may pass through couplers. Since a coupler's aluminum housing is physically connected to a ground conductor pin in a coupler, and a coupler housing is mechanically connected to a metal frame of underground mining equipment, such mechanical connection also provides a signal path to ground connection. **Figure 14** illustrates one embodiment of a signal isolation ring **1400** operable to prevent a signal path to ground before it is received by a broadband communication device in mining equipment. In one embodiment, signal isolation ring **1400** may comprise a first isolation ring **1410** and a second isolation ring **1420**. One or more insulating devices, such as an electrical bushing **1430** may separate first isolation ring **1410** from second isolation ring **1420**. In one embodiment, first isolation ring **1410** may be operatively connected to an inside of an equipment frame **1440** and second isolation ring **1420** may be operatively connected to an outside of an equipment frame **1450** such that an electrical connection established through signal isolating ring **1400** on worksite

equipment (not shown) will insulate signals on wire **1470** from being grounded by frames **1440** and **1450** when a broadband communication device (not shown) integrated on worksite equipment (not shown) is operatively connected to wire **1470**.

[0067] With respect to mine electrical distribution system **100** illustrated in **Figure 1**, the mine may benefit from this embodiment, for example, by utilizing one or more instances of the embodiment in one or more of the locations power center **120**, switchhouse **110**, and conveyor belt starter **180**.

[0068] To the extent that the term “includes” or “including” is used in the specification or the claims, it is intended to be inclusive in a manner similar to the term “comprising” as that term is interpreted when employed as a transitional word in a claim. Furthermore, to the extent that the term “or” is employed (e.g., A or B) it is intended to mean “A or B or both.” When the applicants intend to indicate “only A or B but not both” then the term “only A or B but not both” will be employed. Thus, use of the term “or” herein is the inclusive, and not the exclusive use. See Bryan A. Garner, *A Dictionary of Modern Legal Usage* 624 (2d. Ed. 1995). Also, to the extent that the terms “in” or “into” are used in the specification or the claims, it is intended to additionally mean “on” or “onto.” To the extent that the term “substantially” is used in the specification or the claims, it is intended to take into consideration the degree of precision available or prudent in manufacturing. To the extent that the term “selectively” is used in the specification or the claims, it is intended to refer to a condition of a component wherein a user of the apparatus may activate or deactivate the feature or function of the component as is necessary or desired in use of the apparatus. To the extent that the term “operatively connected” is used in the specification or the claims, it is intended to mean that the identified components are connected in a way to perform a designated function. As used in the specification and the claims, the singular forms “a,” “an,” and “the” include the plural. Finally, where the term “about” is used in conjunction

with a number, it is intended to include $\pm 10\%$ of the number. In other words, “about 10” may mean from 9 to 11. Notwithstanding that the numerical ranges and parameters setting forth the broad scope of the invention are approximations, the numerical values set forth in the specific examples are reported as precisely as possible. Any numerical value, however, inherently contains certain errors necessarily resulting from the standard deviation found in their respective testing measurements.

[0069] As stated above, while the present application has been illustrated by the description of embodiments thereof, and while the embodiments have been described in considerable detail, it is not the intention of the applicants to restrict or in any way limit the scope of the appended claims to such detail. Additional advantages and modifications will readily appear to those skilled in the art, having the benefit of the present application. Therefore, the application, in its broader aspects, is not limited to the specific details, illustrative examples shown, or any apparatus referred to. Departures may be made from such details, examples, and apparatuses without departing from the spirit or scope of the general inventive concept.

CLAIMS

What is claimed:

1. An underground mining communication system comprising:
a power center, the power center providing electrical energy via one or more electrical connection;
one or more mining power cable, the one or more mining power cable operable to connect to the power center, one or more broadband communication device, and mining equipment;
one or more frequency blocking device;
one or more broadband communication device operable to at least one of modulate, demodulate, recondition, repeat, transmit, and receive communication signals via the one or more mining power cable and further operable to communicate with another one or more broadband communication device.
2. The underground mining communication system of claim 1, wherein a first broadband communication device is operatively connected to the one or more mining power cable and the power center.
3. The underground mining communication system of claim 2, wherein the power center comprises: one or more power distribution transformer, the one or more power distribution transformer operable to transfer an electrical energy from one or more electrical energy input to one or more energy output, wherein the one or more power distribution transformer has a primary winding and a secondary winding;
the underground mining communication system further comprising one or more second broadband communication device, the one or more second broadband communication device operatively connected to the one or more mining power cable and the primary winding of the one or more power distribution transformer.

4. The underground mining communication system of claim 3, further comprising
one or more third broadband communication device, the one or more third broadband communication device operatively connected to the secondary winding of the one or more power distribution transformer and the one or more mining power cable.

5. The underground mining communication system of claim 4, further comprising
one or more fourth broadband communication device operatively connected to the mining equipment and the one or more mining power cable, such that the one or more fourth broadband communication device is operatively connected to the first one or more first broadband communication device such that the one or more first broadband communication may transmit and receive signals to and from the one or more fourth broadband communication device via the one or more mining power cable, the one or more second broadband communication device, and the one or more third broadband communication device.

6. The underground mining communication system of claim 1, wherein the mining equipment is a fixed mining equipment.

7. The underground mining communication system of claim 1, wherein the mining equipment is a mobile mining equipment.

8. The underground mining communication system of claim 1, wherein the one or more mining power cable is a power feeder cable.

9. The underground mining communication system of claim 8, wherein the power feeder cable comprises one of a MPF-GGC and MP-GC type cable.

10. The underground mining communication system of claim 1, wherein the one or more mining power cable may comprise a trailing power cable.
11. The underground mining communication system of claim 1, wherein the one or more mining power cable is a shielded power cable.
12. The underground mining communication system of claim 1, wherein the one or more frequency blocking device is a low pass filter.
13. The underground mining communication system of claim 12, wherein the one or more power distribution system comprises a signal path to ground and the low pass filter is operatively connected to the signal path to ground.
14. The underground mining communication system of claim 1, wherein the one or more broadband communication device is a BPL device.
15. The underground mining communication system of claim 1, wherein the power center comprises one or more emergency stop switches and the one or more frequency blocking device is operatively connected to the one or more emergency stop switches.
16. The underground mining communication system of claim 1, wherein the power center comprises one or more interlock switches and the one or more frequency blocking device is operatively connected to the one or more interlock switches.
17. An underground mining communication system comprising:
 - a power distribution system, the power distribution system comprising:
 - a substation,
 - a switchgear,
 - and one or more power center, the one or more power center comprising:
 - one or more electrical energy input,
 - one or more electrical energy output,

one or more connection operatively connected to the one or more

electrical energy output,

one or more power distribution transformer, the one or more power distribution transformer operable to transfer an electrical energy from the one or more electrical energy input to the one or more energy output, wherein the one or more power distribution transformer has a primary winding and a secondary winding,

at least one signal path to ground,

one or more emergency stop switches,

one or more interlock switches,

the power center further operable to provide the electrical energy via the one or more connection;

one or more mine power cable, the one or more mine power cable having one or more connection and operable to connect to at least one of:

the one or more connection of the power center, one or more connection operatively connected to one or more broadband communication device, and

one or more connection operatively connected to mining equipment;

one or more trailing power cable, the one or more trailing power cable having one or more connection operable to connect to at least one of:

the one or more connection of the power center,

the one or more connection of the one or more broadband communication device, and

the one or more mechanical connection of the mining equipment;

one or more first frequency blocking device, the one or more first frequency blocking device is operatively connected to the signal path to ground of the power center, and wherein the first frequency blocking device is a low pass filter;

one or more second frequency blocking device, the one or more second frequency blocking device, is operatively connected to at least one of:

the one or more emergency stop switches of the power center,

the one or more interlock switches of the power center, and

one or more first broadband communication device, the first broadband communication device operatively connected to the one or more mine power cable, the first broadband communication operable to at least one of modulate and demodulate signals, and transmit and receive signals via the one or more mine power cable;

one or more second broadband communication device, the one or more second broadband communication device operatively connected to the one or more mine power cable and the primary winding of the one or more power distribution transformer, the one or more second broadband communication device operable to at least one of modulate and demodulate signals, and transmit and receive signals via the one or more mine power cable;

one or more third broadband communication device, the one or more third broadband communication device operatively connected to the secondary winding of the one or more power distribution transformer and least one of:

the one or more mine power cable, and

the one or more trailing power cable,

the one or more third broadband communication device operable to at least one of modulate and demodulate signals, and transmit and receive signals via at least one of:

the one or more mine power cable, and

the one or more trailing power cable;

such that the one or more third broadband communication device is operable to communicated with at least the one or more second broadband communication device;

one or more fourth broadband communication device operatively connected to at least one of:

a fixed mining equipment, and

a mobile mining equipment, and

the one or more fourth broadband communication device further operatively connected to at least one of:

the one or more mine power cable, and

the one or more trailing power cable,

the one or more fourth broadband communication device operable to at least one of modulate and demodulate signals, and transmit and receive signals via at least one of:

the one or more mine power cable, and

the one or more trailing power cable,

such that the one or more fourth broadband communication device is operable to communicated with the one or more third broadband communication device via the at least one of:

the one or more mine power cable, and

the one or more trialing power cable,

such that the one or more first broadband communication device, the one or more second broadband communication device, the one or more third broadband communication device, and the one or more fourth broadband communication device are communicatively connected to each other;

a first element within the one or more broadband communication device for transmitting signals; and

a second element within the one or more broadband communication device for receiving signals.

18. A method for providing broadband communication over mine power cabling in underground mines, the method comprising:

connecting at least a first broadband communication device to one or more mine power cabling;

connecting at least a second broadband communication device to a power center and the one or more mine power cabling, wherein the second broadband communication device is connected to a primary winding of a distribution transformer of the power center;

connecting at least a third broadband communication device to a secondary winding of the distribution transformer of the power center and the one or more mine power cabling;

connecting at least a fourth broadband communication device to mining equipment within an underground mine and the one or more mine power cabling;

generating a signal that will be transmitted by at least one of: a first broadband communication device, a second broadband communication device, a third broadband communication device, and a fourth broadband communication device;

modulating the generated signal to be transmitted over the one or more mine power cable;

transmitting the modulated signal over the one or more mine power cable;

preventing communication signal loss over the one or more mine power cable using at least one frequency blocking device;

receiving the modulated signal at at least one of: the first broadband communication device, the second broadband communication device, the third broadband communication device, and the fourth broadband communication device, the at least one receiving broadband communication device different than the at least one transmitting broadband communication device; and

demodulating the received signal, the demodulated signal to be further processed by the at least one receiving broadband communication device.

19. The method of claim 18, wherein transmitting and receiving the signal are via the one or more mine power cabling, the one or more mine power cabling one of a MPF-GGC and MP-GC type cable.

20. The method of claim 18, wherein transmitting and receiving the signal are via the one or more mine power cabling, the one or more mine power cabling is a shielded cable.

21. The method of claim 18, further comprising filtering the signal using any one of the first broadband communication device, the second broadband communication device, the third broadband communication device, and the fourth broadband communication device.

22. The method of claim 18, further comprising blocking a frequency using a frequency blocking device.

23. The method of claim 18, further comprising monitoring the signal using any one of the first broadband communication device, the second broadband communication device, the third broadband communication device, and the fourth broadband communication device.

24. The method of claim 18, further comprising monitoring a signal to noise ratio of the signal using any one of the first broadband communication device, the second broadband communication device, the third broadband communication device, and the fourth broadband communication device.

25. The method of claim 18, further comprising collecting data using any one of the first broadband communication device, the second broadband communication device, the third broadband communication device, and the fourth broadband communication device.

26. The method of claim 18, further comprising repeating the signal using any one of the first broadband communication device, the second broadband communication device, the third broadband communication device, and the fourth broadband communication device.

27. The method of claim 18, further comprising amplifying the signal using any one of the first broadband communication device, the second broadband communication device, the third broadband communication device, and the fourth broadband communication device.

28. The method of claim 18, wherein the connected at least first broadband communication device, the connected at least second broadband communication device, the connected at least third broadband communication device, and the connected at least fourth broadband communication device is a BPL device.

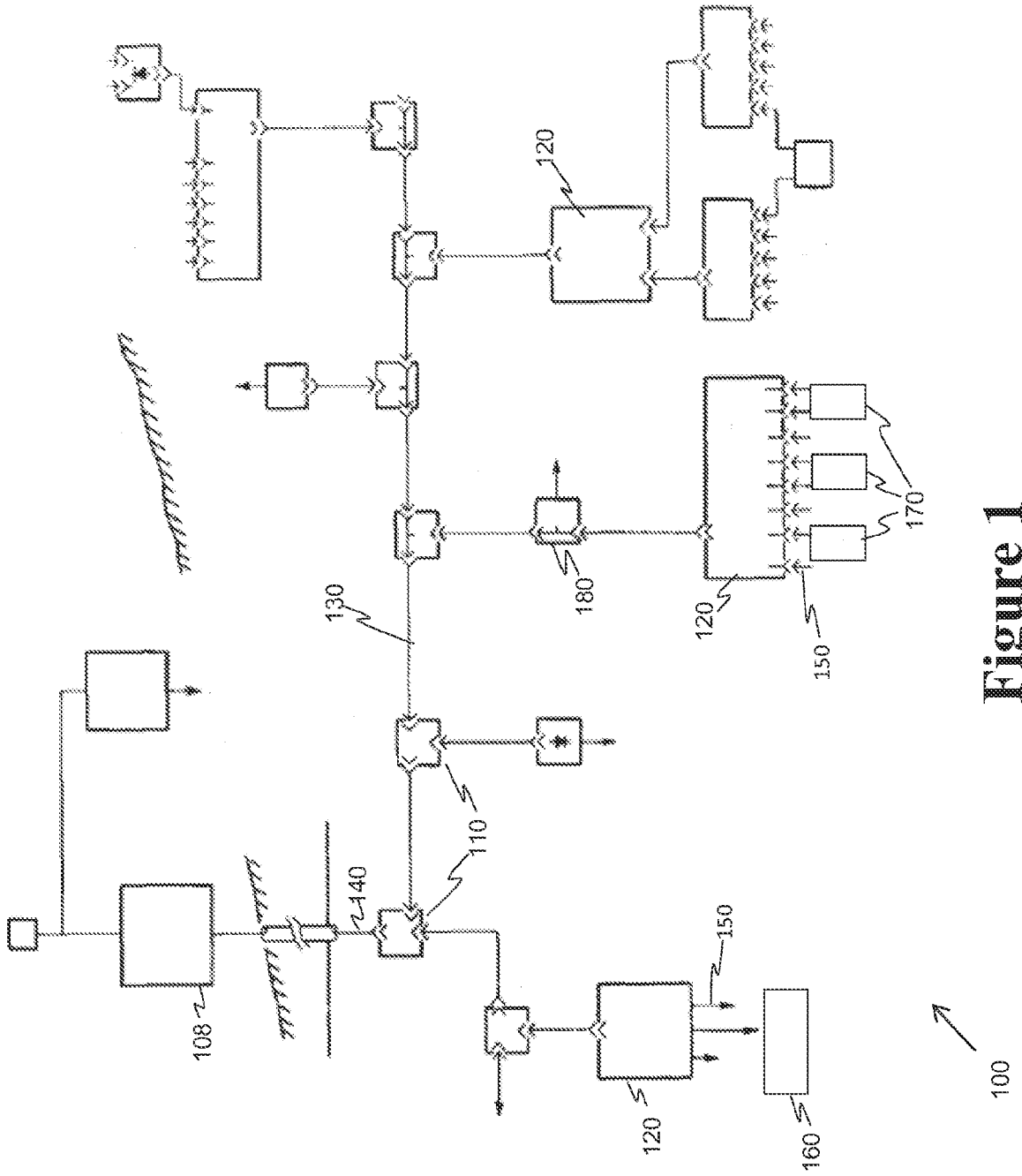

Figure 1

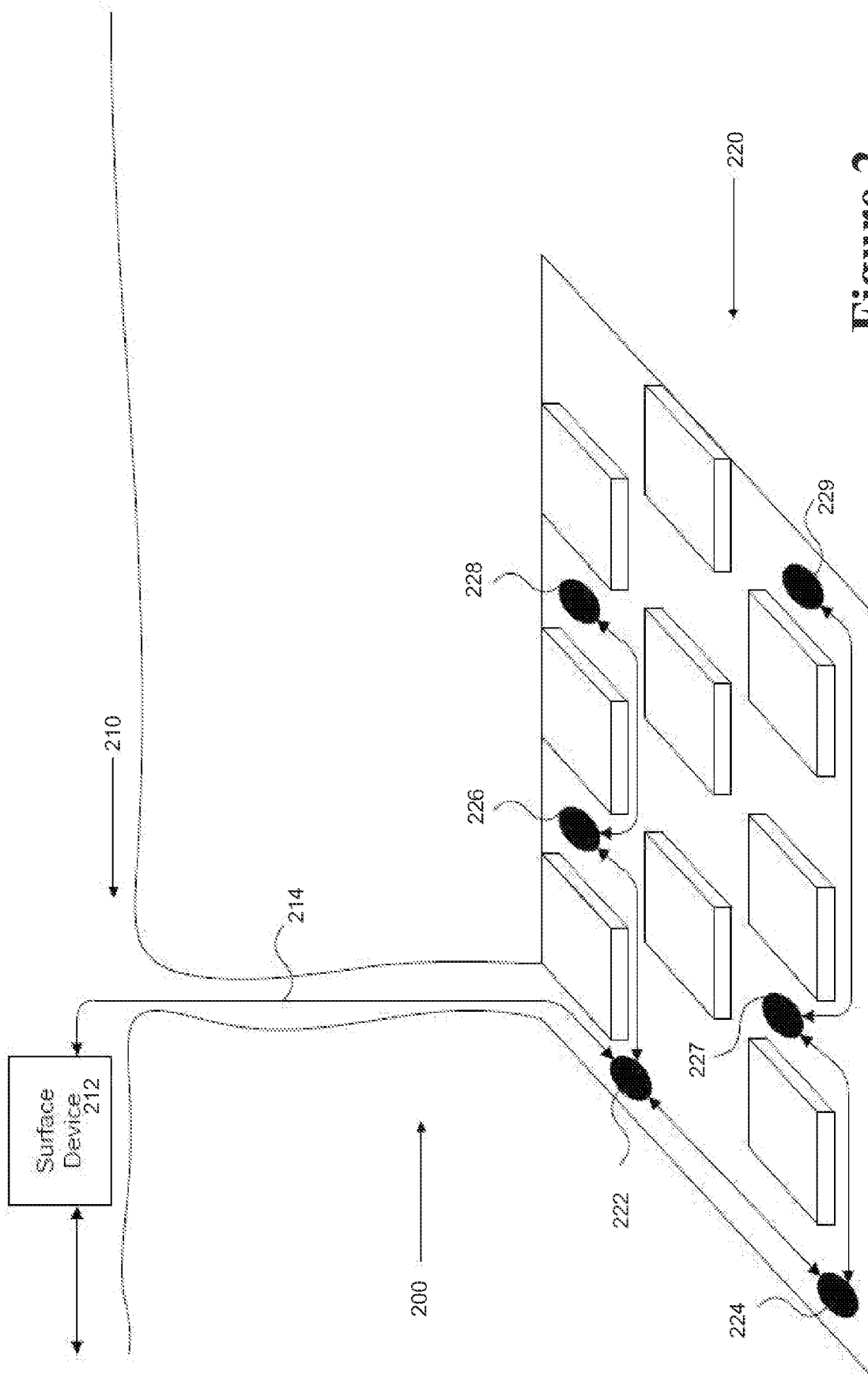

Figure 2

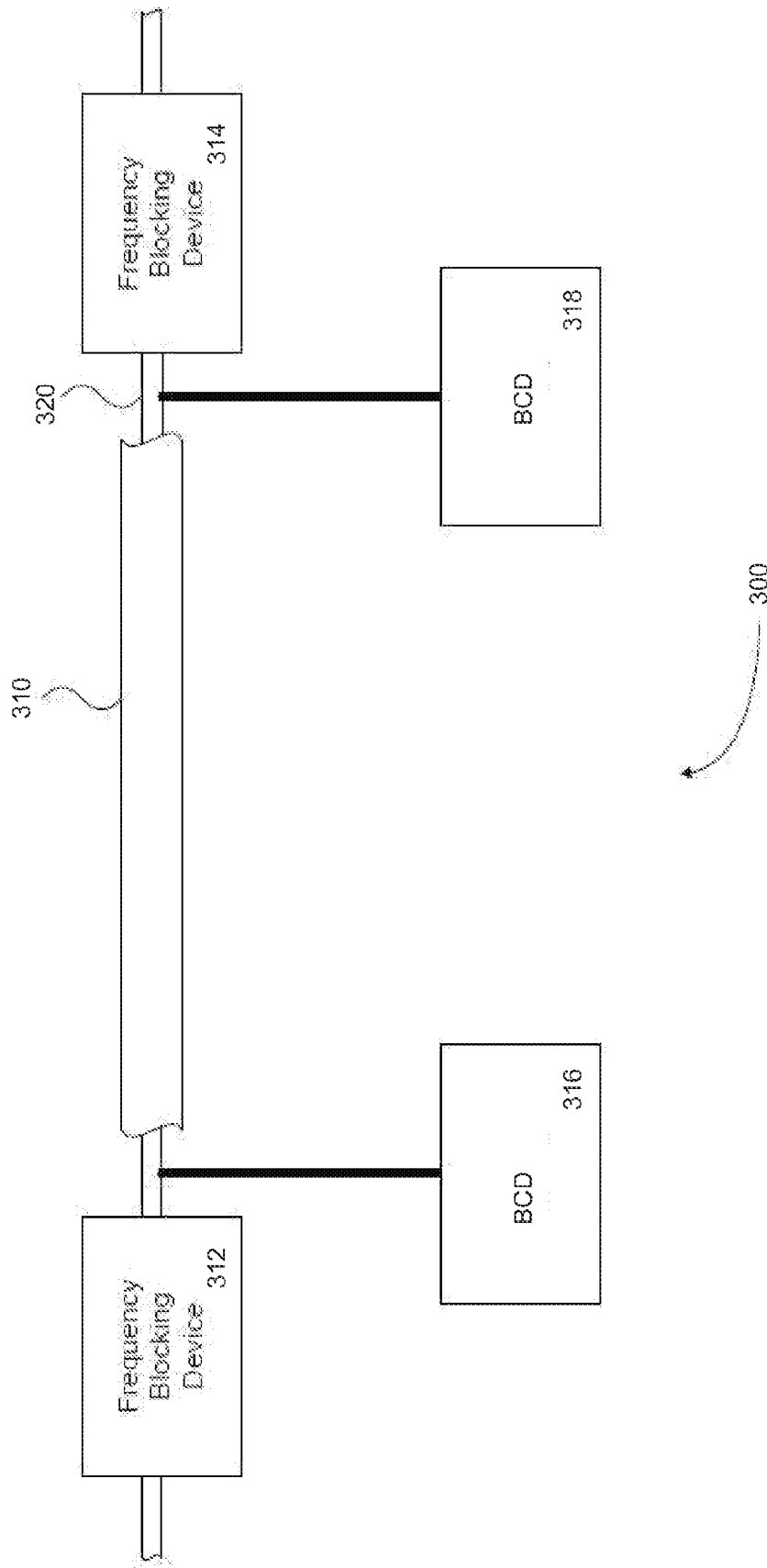

Figure 3

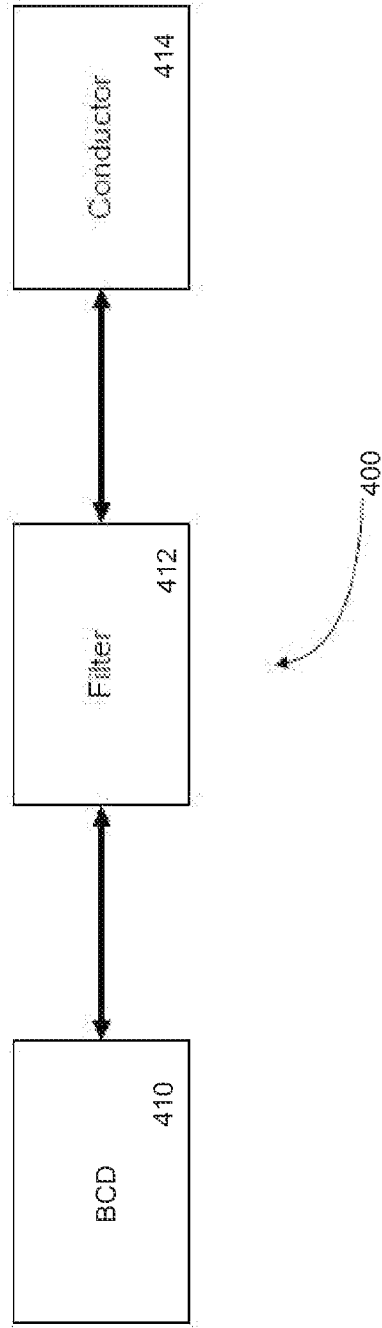

Figure 4

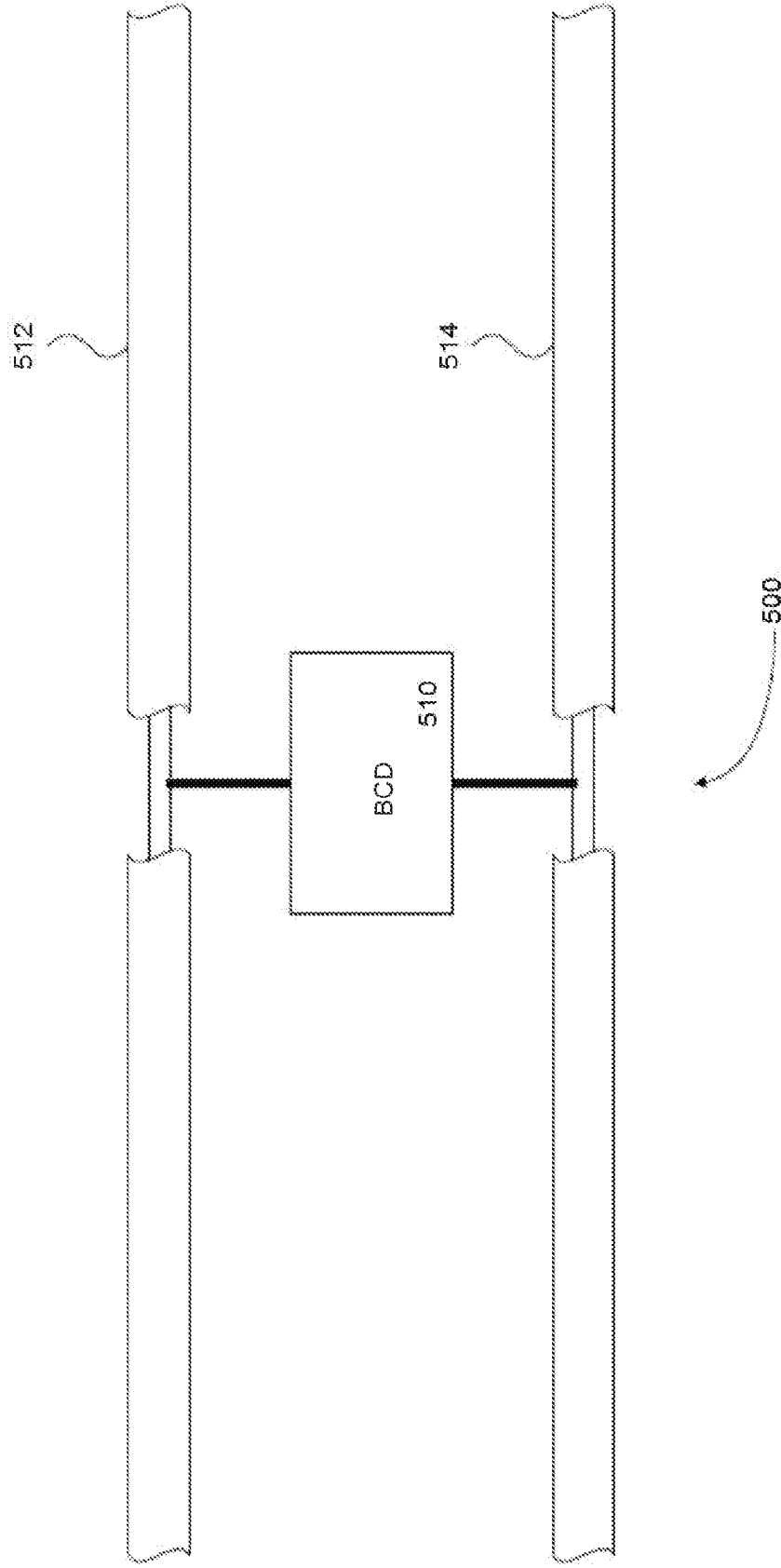

Figure 5

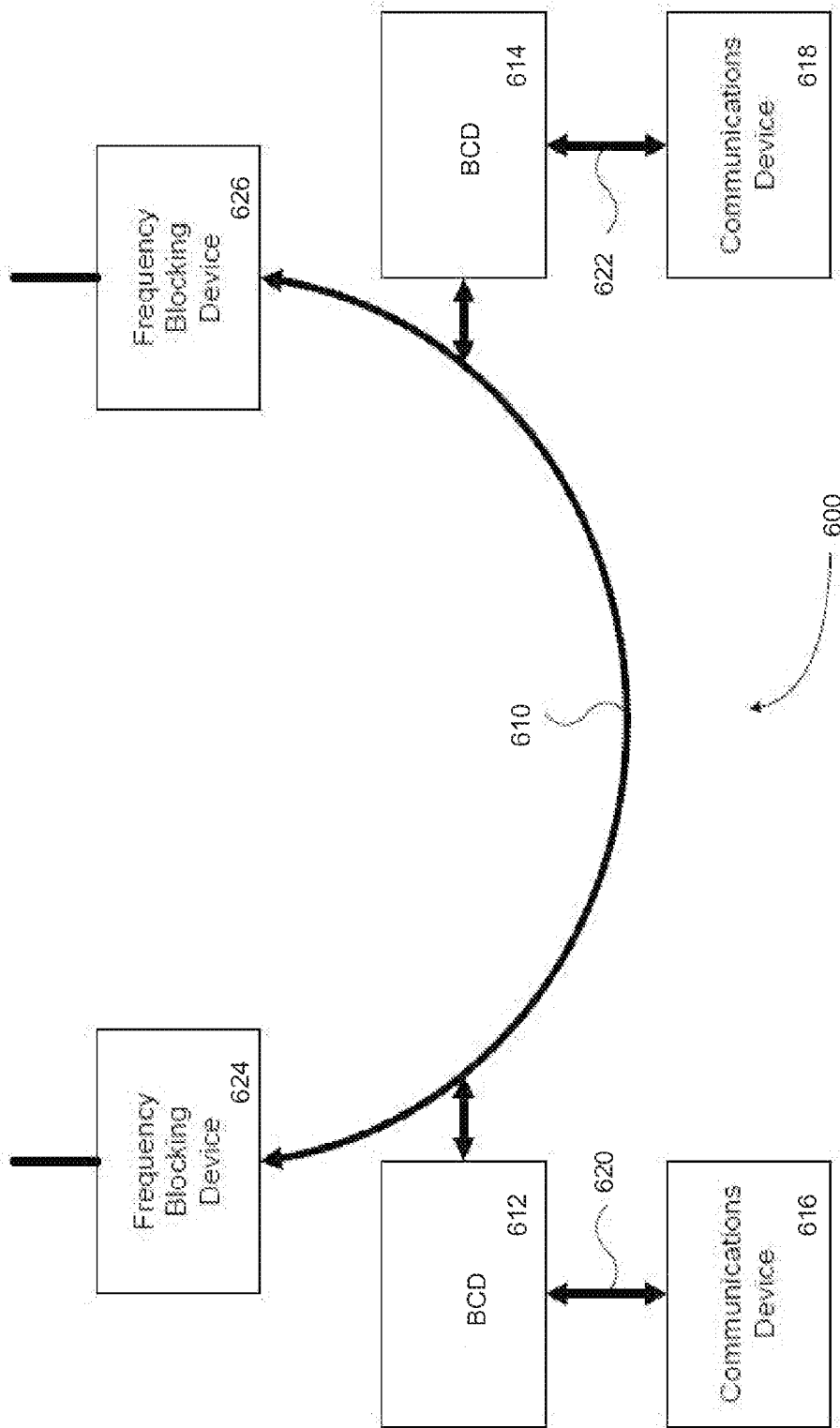

Figure 6

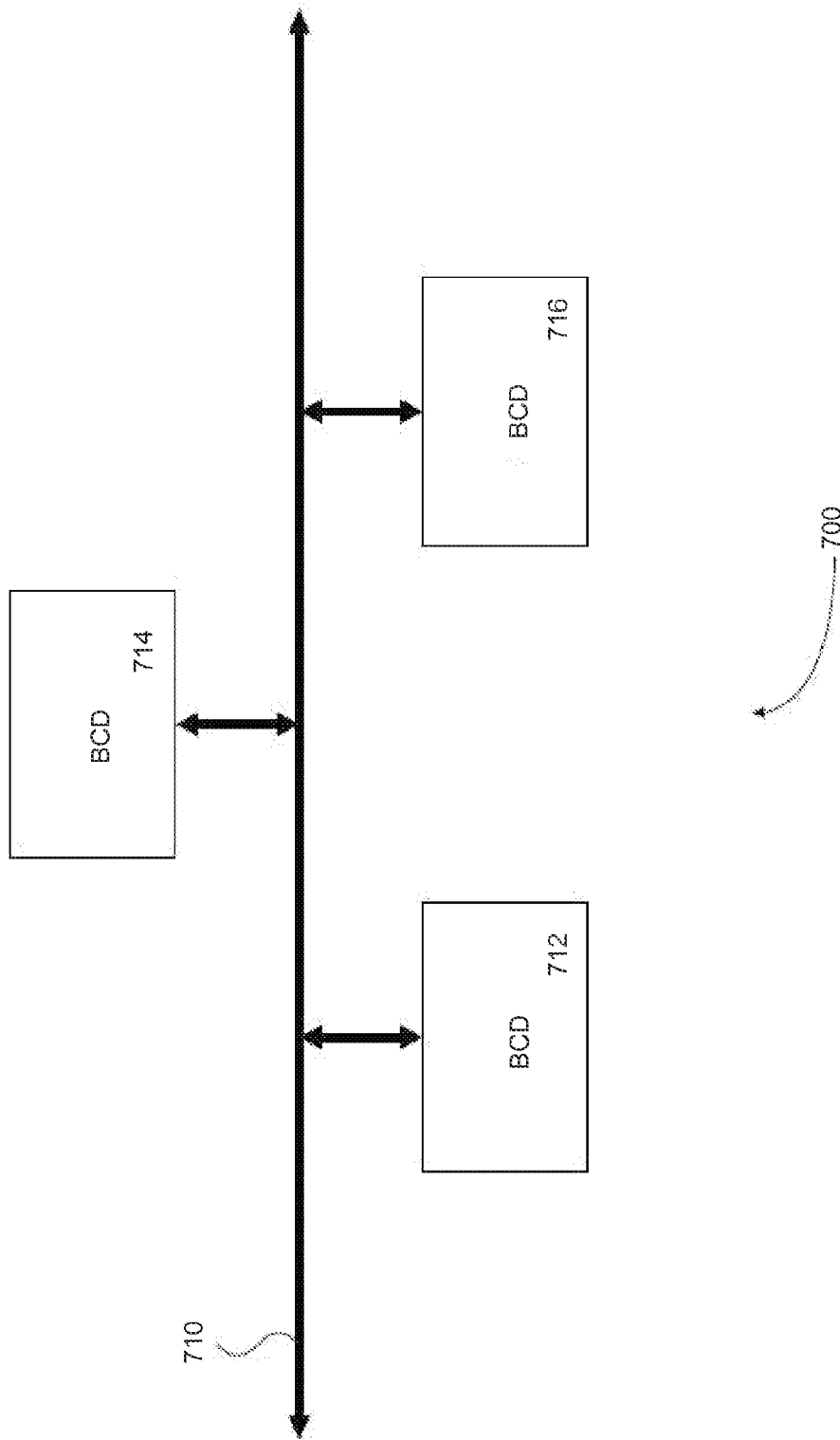

Figure 7

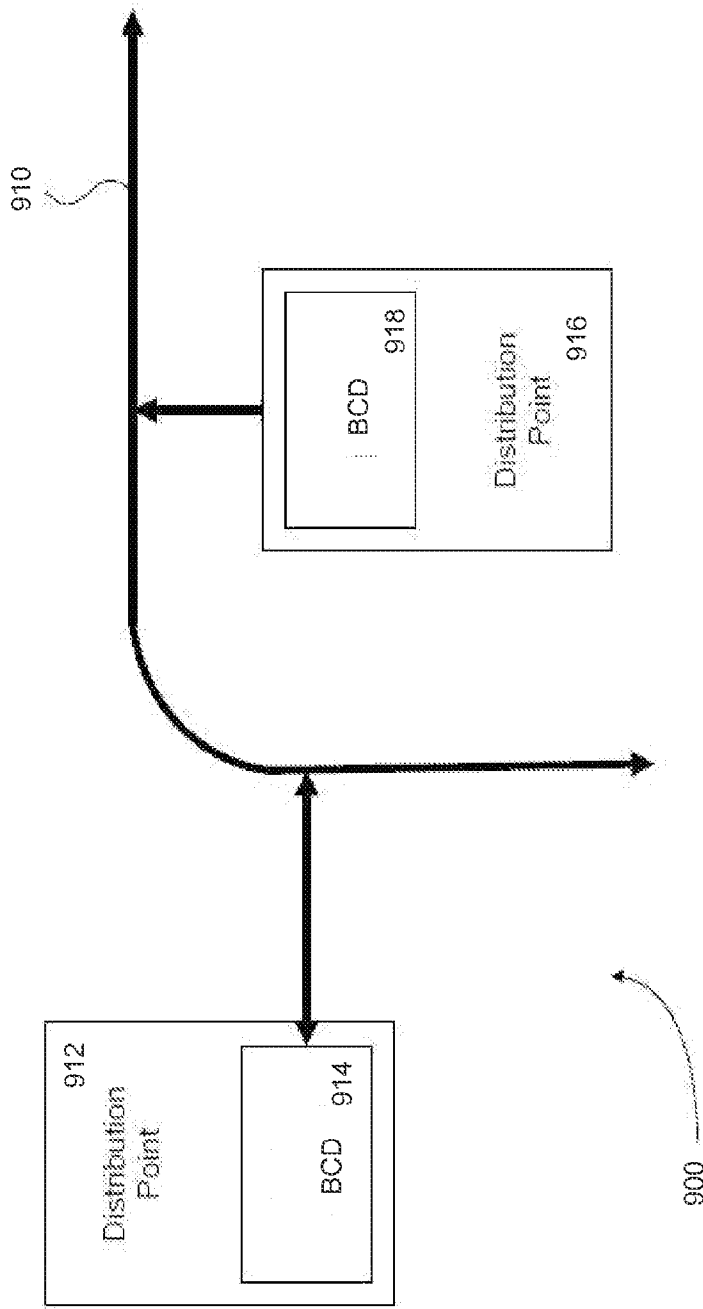

Figure 9

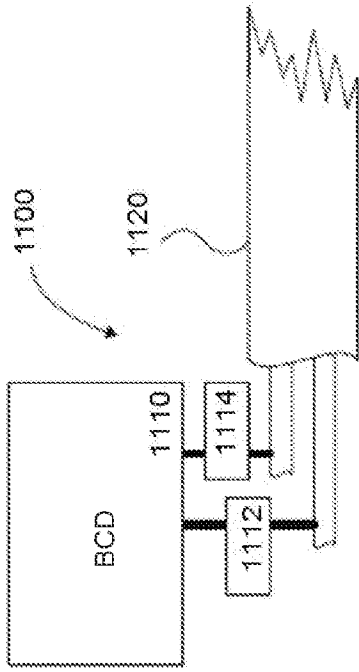

Figure 10

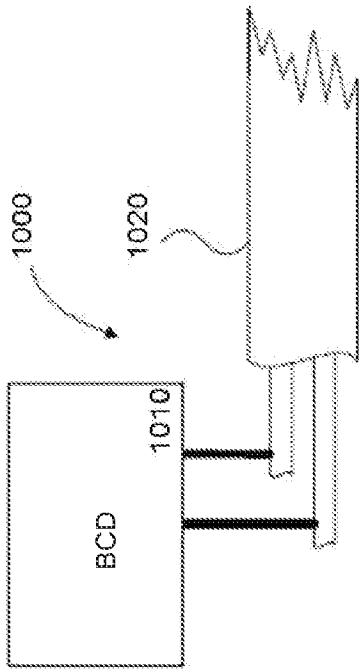

Figure 11

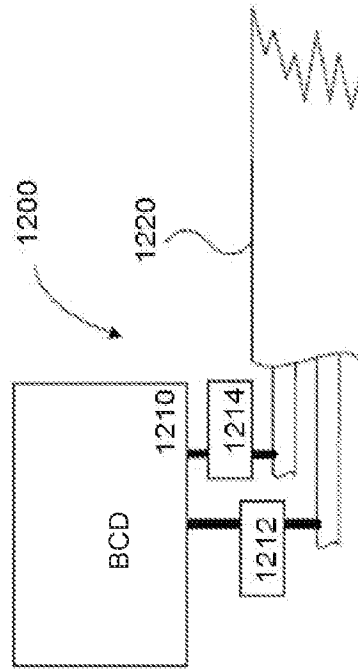

Figure 12

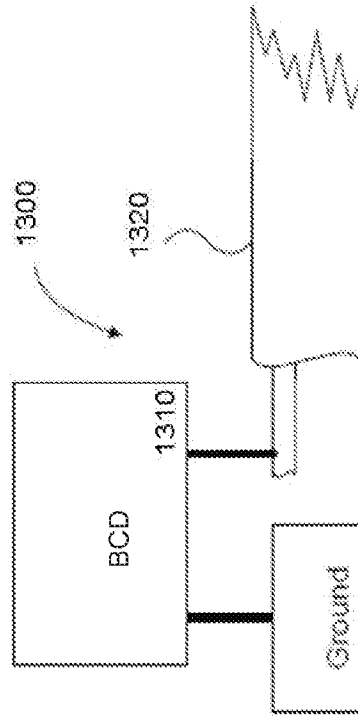

Figure 13

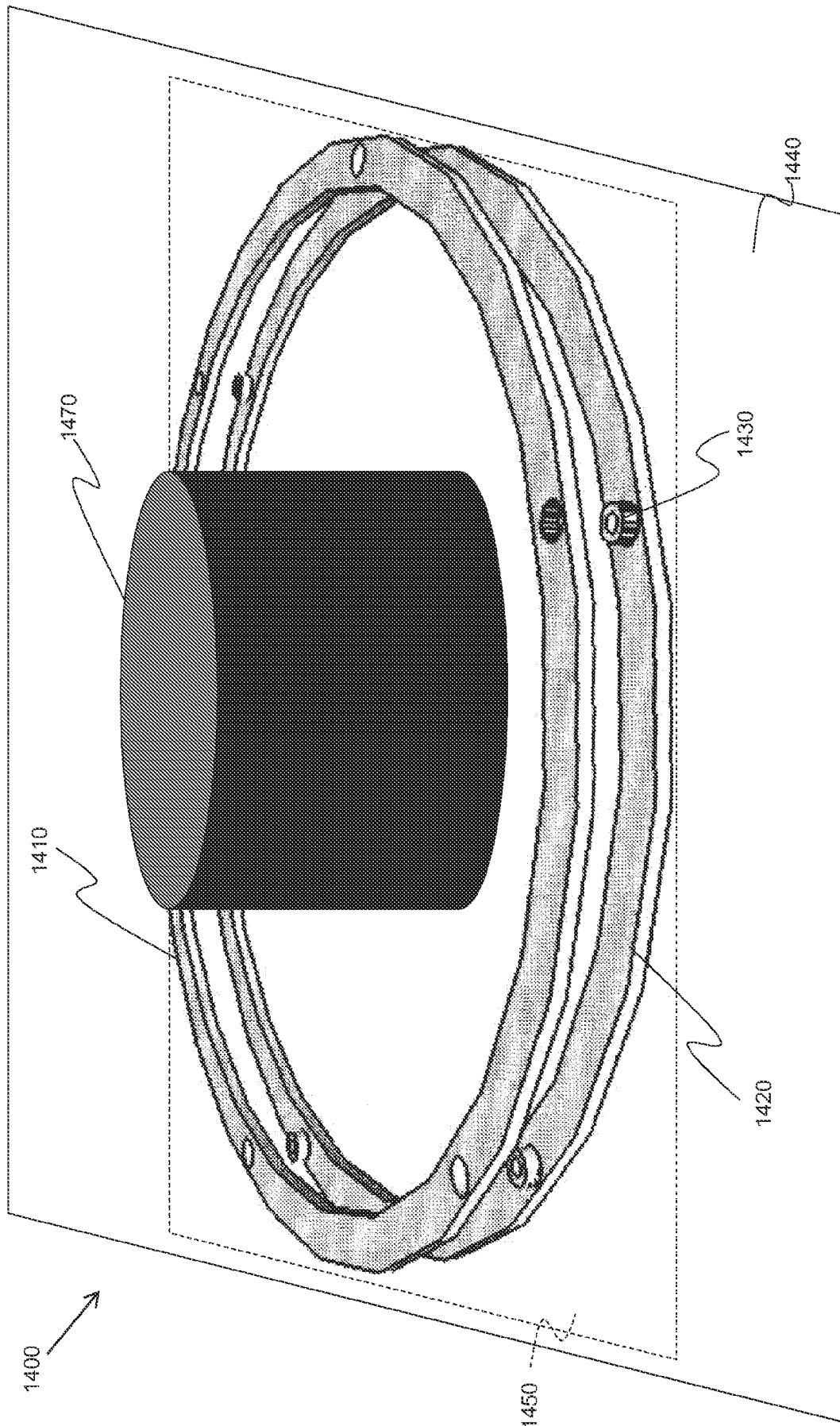

Figure 14

INTERNATIONAL SEARCH REPORT

International application No.
PCT/US2013/071045

A. CLASSIFICATION OF SUBJECT MATTER IPC(8) - G01B 1/08 (2014.01) USPC - 340/538 According to International Patent Classification (IPC) or to both national classification and IPC		
B. FIELDS SEARCHED Minimum documentation searched (classification system followed by classification symbols) IPC(8) - E21C 35/00; G01B 1/00; G06F 19/00; H04B 5/00 (2014.01) USPC - 299/1.05; 340/538, 340/649; 455/560 Documentation searched other than minimum documentation to the extent that such documents are included in the fields searched CPC - E21C 35/00; G01B 1/00; G06F 19/00 (2013.01) Electronic data base consulted during the international search (name of data base and, where practicable, search terms used) PatBase, Google Patents, ProQuest		
C. DOCUMENTS CONSIDERED TO BE RELEVANT		
Category*	Citation of document, with indication, where appropriate, of the relevant passages	Relevant to claim No.
Y	US 5,967,616 A (OFFUTT et al) 19 October 1999 (19.10.1999) entire document.	1-28
Y	WO 2012/009754 A1 (WILMOT et al) 26 January 2012 (26.01.2012) entire document.	1-28
Y	US 5,349,644 A (MASSEY et al) 20 September 1994 (20.09.1994) entire document.	3-5, 17-28
Y	US 2009/0128347 A1 (BUCELLA et al) 21 May 2009 (21.05.2009) entire document.	17
A	US 2010/0076612 A1 (ROBERTSON) 25 March 2010 (25.03.2010) entire document.	1-28
A	US 2009/0140852 A1 (STOLARCZYK et al) 04 June 2009 (04.06.2009) entire document.	1-28
A	US 2010/0256862 A1 (VERHARDT) 07 October 2010 (07.10.2010) entire document.	1-28
<input type="checkbox"/> Further documents are listed in the continuation of Box C. <input type="checkbox"/>		
* Special categories of cited documents: "A" document defining the general state of the art which is not considered to be of particular relevance "E" earlier application or patent but published on or after the international filing date "L" document which may throw doubts on priority claim(s) or which is cited to establish the publication date of another citation or other special reason (as specified) "O" document referring to an oral disclosure, use, exhibition or other means "P" document published prior to the international filing date but later than the priority date claimed "T" later document published after the international filing date or priority date and not in conflict with the application but cited to understand the principle or theory underlying the invention "X" document of particular relevance; the claimed invention cannot be considered novel or cannot be considered to involve an inventive step when the document is taken alone "Y" document of particular relevance; the claimed invention cannot be considered to involve an inventive step when the document is combined with one or more other such documents, such combination being obvious to a person skilled in the art "&" document member of the same patent family		
Date of the actual completion of the international search 20 March 2014		Date of mailing of the international search report <div style="font-size: 24pt; font-weight: bold; text-align: center;">14 APR 2014</div>
Name and mailing address of the ISA/US Mail Stop PCT, Attn: ISA/US, Commissioner for Patents P.O. Box 1450, Alexandria, Virginia 22313-1450 Facsimile No. 571-273-3201		Authorized officer: Blaine R. Copenheaver PCT Helpdesk: 571-272-4300 PCT OSP: 571-272-7774