



(12) **EUROPEAN PATENT APPLICATION**

(43) Date of publication:
14.10.2015 Bulletin 2015/42

(51) Int Cl.:
H04R 25/00 ^(2006.01) **H04R 1/06** ^(2006.01)

(21) Application number: **14164143.1**

(22) Date of filing: **10.04.2014**

(84) Designated Contracting States:
AL AT BE BG CH CY CZ DE DK EE ES FI FR GB GR HR HU IE IS IT LI LT LU LV MC MK MT NL NO PL PT RO RS SE SI SK SM TR
 Designated Extension States:
BA ME

(72) Inventors:
 • **Nielsen, Henrik**
4000 Roskilde (DK)
 • **Johansen, Jan**
4600 Køge (DK)

(71) Applicant: **GN ReSound A/S**
2750 Ballerup (DK)

(74) Representative: **Guardian IP Consulting I/S**
Diplomvej, Building 381
2800 Kgs. Lyngby (DK)

(54) **A hearing aid**

(57) A hearing aid comprising a hearing aid housing (1) with a receiver (5), and a filter (6), e.g. a cerumen filter, wherein the hearing aid housing (1) comprises an outer surface and an internal cavity adapted for containing the receiver (5) and where the hearing aid housing (1) further comprises a filter socket (9) wherein the filter (6) is releasably mounted, and where the filter socket (9)

is adapted for providing a sound channel extending through the filter (6) between the outer surface and the receiver (5), and wherein the filter socket (9) and the receiver (5) are relatively sized in order to allow for insertion of the receiver (5) through the channel and into the internal cavity, when the filter (6) is dismantled from the filter socket (9).

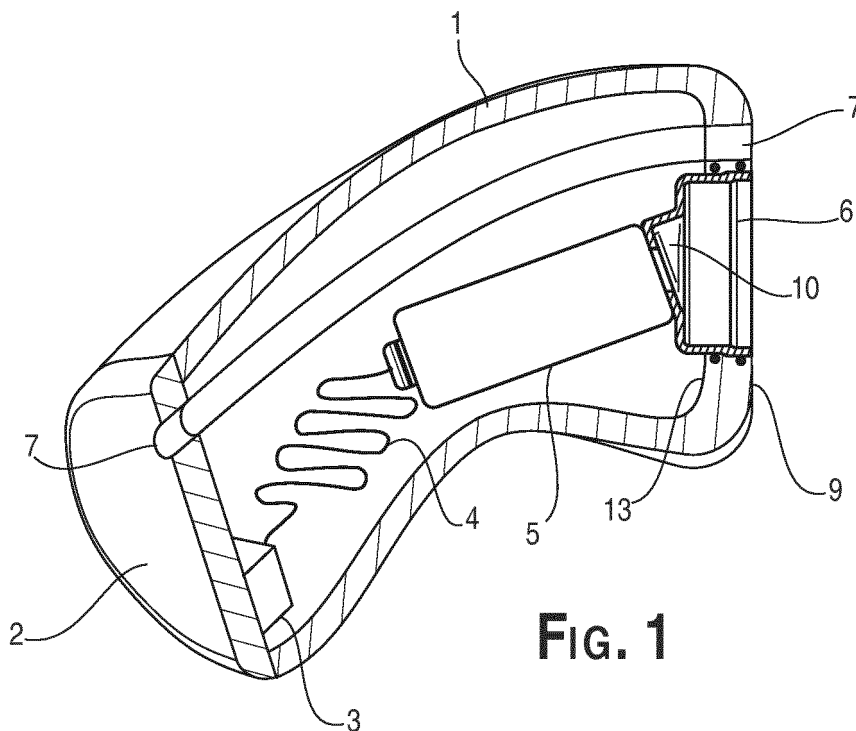

FIG. 1

Description

[0001] The present invention relates to a hearing aid comprising a housing with a receiver/loudspeaker, and a filter, e.g. a cerumen filter, where the housing comprises an outer surface and an internal cavity adapted for containing the receiver/loudspeaker and where the housing further comprises a filter socket wherein the filter is releasably mounted, and where the filter socket is adapted for providing a sound channel extending through the filter between the outer surface and the receiver

Description of related art

[0002] Hearing aids of the above mentioned kind are known in a lot of different embodiments, where the filter is mostly used as a wax guard with the primary purpose of avoiding ear wax from migrating into the receiver.

[0003] Especially in relation to ITE "In The Ear" hearing aids there is an ongoing research and development with respect to provide ITE hearing aids with optimal sound quality and performance on the one hand, and on the other hand providing a hearing aid being as discrete as possible in the ear of the user. This requires that the components of the hearing aid, such as e.g. the receiver, the filter and its socket, and the electronics used for providing the audible signal are to be arranged in ever smaller spaces, and at the same time providing good sound quality.

Summary of the invention

[0004] The purpose of the present invention is therefore to provide a hearing aid where especially the receiver and the filter socket is easy to dismantle for servicing or exchanging than what is the case with the prior hearing aids.

[0005] This is obtained with the hearing aid mentioned in the introduction, and wherein the filter socket and the receiver/loudspeaker are relatively sized in order to allow for insertion or removal of the receiver/loudspeaker through the channel and into or out of the internal cavity respectively, when the filter is dismantled from the filter socket.

[0006] In a preferred embodiment the filter comprises a filter holder, and a filter unit, and where the filter holder and the filter unit are adapted for releasably mounting of the filter unit in the filter holder, and the filter holder is attached in the filter socket.

[0007] In a further preferred embodiment the receiver/loudspeaker comprises a receiver housing having a first substantially plane side face with a sound opening, and the filter holder comprises a substantially plane bottom plate, and where the filter holder is fastened to the receiver housing, so that the substantially plane bottom plate of the filter holder abuts the substantially plane side face of the receiver housing, and so that the sound opening is aligned with the first opening.

[0008] The substantially plane bottom plate may in a further preferred embodiment be fastened to the first substantially plane side face of the receiver housing, so that the receiver and filter holder can be mounted or dismantled as a unit.

[0009] In this relation the filter holder may preferably be permanently fastened to the receiver housing by gluing, soldering or welding, and the filter holder releasably attached to the housing with a press fit, a frictional fit, or by means of heat releasable glue.

[0010] In a preferred embodiment the hearing aid further comprises a signal processor arranged in the internal cavity of the housing, and being adapted for providing an audio signal to the receiver/loudspeaker via a set of electrical wires extending from the signal processor and to the receiver, and where the length of the electrical wires are so long that the receiver can be pulled out of the internal cavity through the filter socket, without the need of dismantling or stretching the electrical wires.

[0011] In a preferred embodiment the receiver housing extends within a substantially uniform rectangular cross section in all planes being parallel to the first substantially plane side face, and the filter holder has a cylindrical outer surface defining an outer diameter, where the diagonal dimension of the substantially uniform cross section of the receiver housing is smaller than the outer diameter of the filter holder.

Brief description of the drawings

[0012] In the following, the invention will be described in greater detail with reference to embodiments shown by the enclosed figures. It should be emphasized that the embodiments shown are used for example purposes only and should not be used to limit the scope of the invention.

Fig. 1: Is a principle drawing showing a cross section of a hearing aid according to the invention.

Fig. 2: Shows the filter/receiver assembly shown in fig. 1.

Fig. 3: Is a perspective view of the assembled filter and receiver shown in fig. 1 and 2.

Fig. 4: Is a principle drawing showing a cross section of another embodiment of a hearing aid according to the invention.

Fig. 5: Shows the filter/receiver assembly shown in fig. 4.

Fig. 6 Is a perspective view of the filter/receiver assembly shown in fig. 4 and 5.

Detailed description of the embodiments

[0013] Fig. 1 and 4 are principle drawings showing a cross section through hearing aid according to different embodiments of the invention, These hearing aids are both of the ITE (in the ear) type being adapted for being positioned completely in the ear of the user, but it will be apparent to the skilled person that the invention will also be applicable to other types of hearing aids being only partly positioned in the ear of the user.

[0014] The hearing aids shown in figure 1 and 4 has a hearing aid housing 1 being closed at one end by a face plate 2, which will normally be the only visible part of the hearing aid, when the hearing aid is positioned in the ear of a user. Thereby the hearing aid housing 1 and the face plate 2 encloses an internal cavity 8.

[0015] In hearing aids of the ITE type all functional devices, such as electronics 3, batteries (not shown), wiring 4, a microphone (not shown), a receiver 5 and a cerumen filter holder 6 necessary for the function of the hearing aid have to be positioned in the narrow space provided by the internal cavity 8 in the hearing aid housing 1, and therefore it is important to have a high degree of freedom with respect to positioning each device in an optimal position in order to optimally utilize the space in the hearing aid housing 1.

[0016] As it is apparent to the skilled person what functional devices are necessary or nice to have in an ITE hearing aid, then only the electronics 3, the wiring 4, the cerumen filter holder 6 and the receiver 5 is shown in fig. 1 and 4. Furthermore fig. 1 shows the filter holder without a filter unit mounted therein, whereas fig. 4 shows that a filter unit 11 is mounted in the filter holder 6.

[0017] Normally the hearing aid housing 1 further comprises e.g. a pressure equalizing channel 7 extending from the internal cavity 8 and to the outer surface 9 on the hearing aid housing 1. This pressure equalizing channel 7 must be arranged so that it is able to equalize pressure differences between the faceplate 2 on the outside of the hearing aid and the closed space in the ear of the user carrying the hearing aid, and thereby further reducing the freedom to position the functional devices in the internal cavity 8 of the hearing aid housing 1.

[0018] In the hearing aid housing 1 a cerumen filter socket 13 is arranged in the end of the hearing aid housing facing the inside of the ear of the user, and the filter holder 6 is mounted in the filter socket 13, having a sound channel 10 extending between the filter holder 6 and the receiver 5.

[0019] The filter holder 6 shown in the figures may e.g. be made from a plastic material, e.g. by injection moulding, or by deep drawing a sheet of metal to the shape shown in figure 1, 2 and 3. In the embodiment shown in fig. 1, 2 and 3 the filter holder 6 is fixed to the plane side face 12 of the receiver 5 by welding, gluing or soldering. In the embodiment shown in fig. 4, 5 and 6 the filter holder 6 is mounted on the receiver 5 by means of a friction fit, a snap fit or by gluing.

[0020] According to the shown embodiments of the invention the filter/filter holder 6 is mounted in the filter socket 13 in the hearing aid housing 1, and the filter socket provides a channel to the internal cavity 8 from the outside of the hearing aid housing 1. According to the invention this passage is made sufficiently large to allow for insertion of the receiver into the internal cavity 8 through the channel. Furthermore the disclosed embodiments show that the receiver 5 is mounted on the filter holder 6 which is mounted in the filter socket 13. As shown in the figures this provides the option of having the receiver 5 suspended only by the filter holder 6, so that it does not touch any parts of the hearing aid housing 1.

[0021] Although some embodiments have been described and shown in detail, the invention is not restricted to them, but may also be embodied in other ways within the scope of the subject matter defined in the following claims. In particular it is to be understood that other embodiments may be utilized and structural and functional modifications may be made without departing from the scope of the present invention. As an example of this it will be apparent to the skilled person that the invention may also be used in relation to hearing aids of another type than the above mentioned ITE type, even though the advantages provided by the invention is especially relevant to the ITE type hearing aids.

[0022] In device claims enumerating several features, several of these features can be embodied by one and the same item of hardware. The mere fact that certain measures are recited in mutually different dependent claims or described in different embodiments does not indicate that a combination of these measures cannot be used to advantage.

[0023] It should be emphasized that the term "comprises/comprising" when used in this specification is taken to specify the presence of stated features, integers, steps or components but does not preclude the presence or addition of one or more other features, integers, steps, components or groups thereof.

Claims

1. A hearing aid comprising a hearing aid housing with a receiver, and a filter, e.g. a cerumen filter, wherein the hearing aid housing comprises an outer surface and an internal cavity adapted for containing the receiver and where the hearing aid housing further comprises a filter socket wherein the filter is releasably mounted, and where the filter socket is adapted for providing a sound channel extending through the filter between the outer surface and the receiver, and wherein the filter socket and the receiver are relatively sized in order to allow for insertion of the receiver through the channel and into the internal cavity, when the filter is dismantled from the filter socket.
2. A hearing aid according to claim 1, wherein the filter

comprises a filter holder and a filter unit, and wherein the filter holder is adapted for releasably mounting of the filter unit in the filter holder, and the filter holder is attached in the filter socket.

unit comprises a filter housing made from a relatively resilient material.

5

3. A hearing aid according to claim 1 or 2, wherein the receiver comprises a receiver housing having a first substantially plane side face with a sound opening, the filter holder comprising a substantially plane bottom plate, and wherein the filter holder is fastened to the receiver housing, in such a way that the substantially plane bottom plate of the filter holder abuts the substantially plane side face of the receiver housing and the sound opening is aligned with the first opening.

10

15

4. A hearing aid according to claim 3, where the substantially plane bottom plate is fastened to the first substantially plane side face of the receiver housing.

20

5. A hearing aid according to claim 3 or 4, where the filter holder is permanently fastened to the receiver housing by gluing, soldering or welding.

6. A hearing aid according to claim 3, 4 or 5, where the filter holder is releasably attached to the filter housing with a press fit, a frictional fit, or by means of heat releasable glue.

25

7. A hearing aid according to claim 1, the hearing aid comprising a signal processor arranged in the internal cavity of the hearing aid housing and being adapted for providing an audio signal to the receiver via a set of electrical wires extending from the signal processor to the receiver, wherein the length of the electrical wires permits pulling the receiver out of the internal cavity through the filter socket, the length being long enough to allow access to the mounting points of the electrical wires without the need of dismantling or stretching the electrical wires.

30

35

40

8. A hearing aid according to claim 1, wherein the receiver housing extends within a substantially uniform rectangular cross section in all planes parallel to the first substantially plane side face, the filter holder has an outer surface conforming to the outer shape of the receiver and defining an outer opening, and wherein the diagonal dimension of the substantially uniform cross section of the receiver housing is smaller than the opening of the filter holder.

45

50

9. A hearing aid according to one or more of the preceding claims, wherein the filter unit is formed as a filter plug adapted for being attached in the filter socket or the filter holder by means of a press fit, or a snap fit.

55

10. A hearing aid according to claim 9, wherein the filter

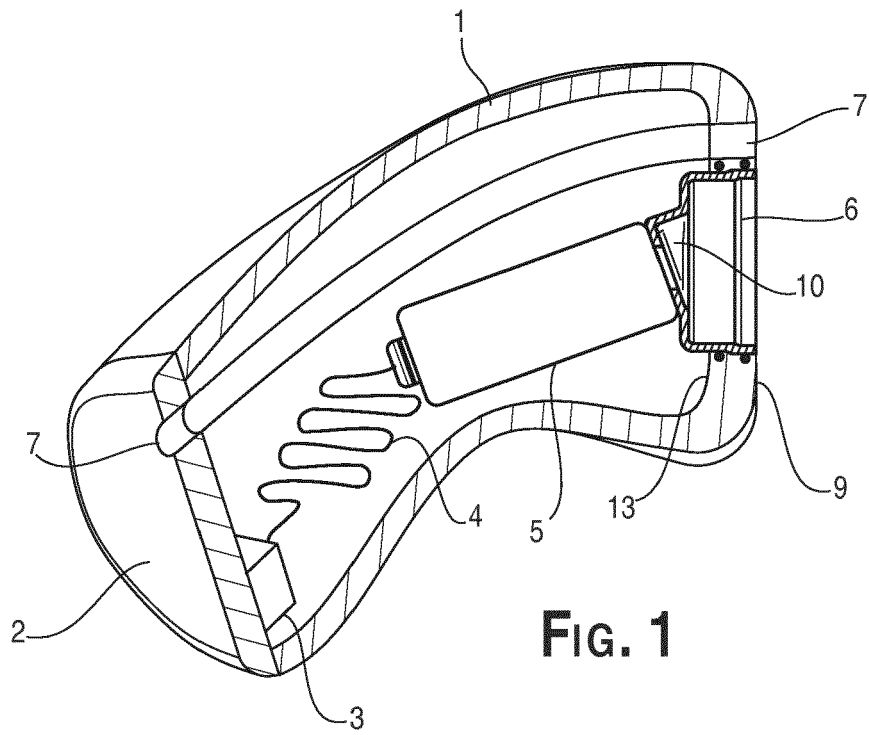

FIG. 1

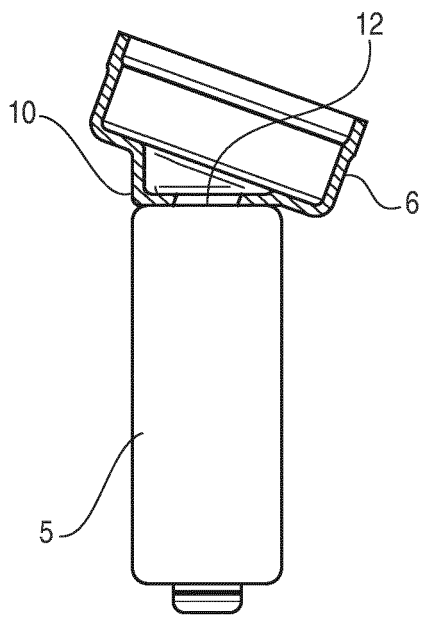

FIG. 2

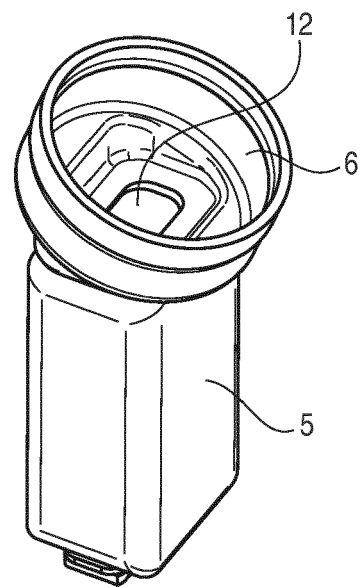
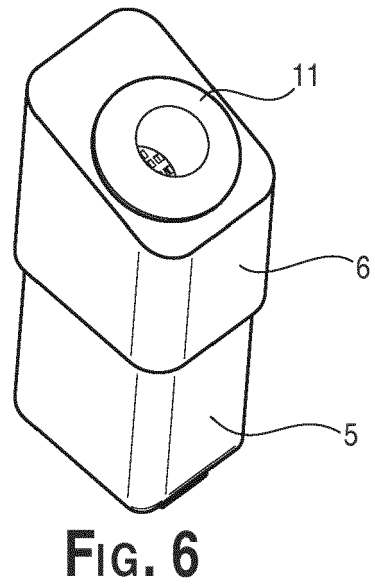
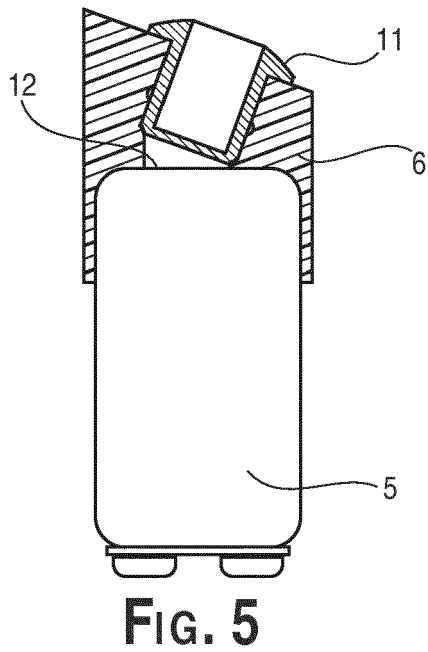
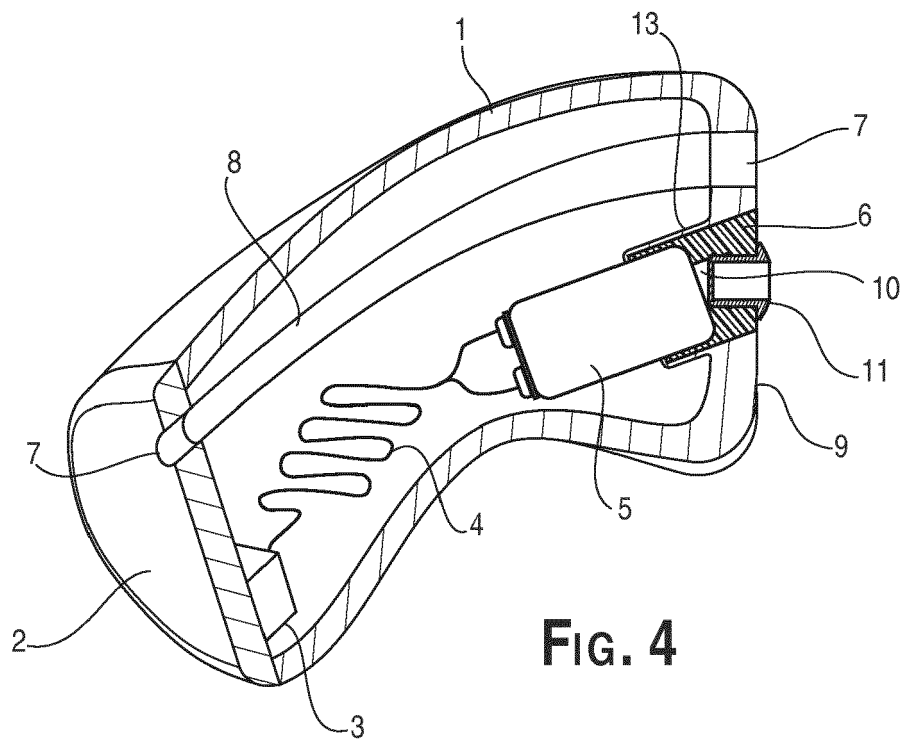

FIG. 3





EUROPEAN SEARCH REPORT

Application Number
EP 14 16 4143

5

10

15

20

25

30

35

40

45

50

55

DOCUMENTS CONSIDERED TO BE RELEVANT			
Category	Citation of document with indication, where appropriate, of relevant passages	Relevant to claim	CLASSIFICATION OF THE APPLICATION (IPC)
X	US 2005/002540 A1 (VONLANTHEN ANDI [CH]) 6 January 2005 (2005-01-06) * paragraph [0036] * * paragraph [0042] - paragraph [0043] * * figures 2a,4-6 *	1-10	INV. H04R25/00 ADD. H04R1/06
X	DE 10 2010 041695 A1 (SIEMENS MEDICAL INSTR PTE LTD [SG]) 25 August 2011 (2011-08-25) * paragraph [0038] - paragraph [0041] * * figure 4 *	1-10	
X	WO 2010/147554 A1 (SIEMENS MEDICAL INSTR PTE LTD [SG]; NG KOK HONG [SG]; LIM MARCUS [SG];) 23 December 2010 (2010-12-23) * page 9, line 33 - page 11, line 11 * * figures 2-4 *	1-10	
			TECHNICAL FIELDS SEARCHED (IPC)
			H04R
The present search report has been drawn up for all claims			
Place of search Munich		Date of completion of the search 6 November 2014	Examiner Fülöp, István
CATEGORY OF CITED DOCUMENTS			
X : particularly relevant if taken alone Y : particularly relevant if combined with another document of the same category A : technological background O : non-written disclosure P : intermediate document		T : theory or principle underlying the invention E : earlier patent document, but published on, or after the filing date D : document cited in the application L : document cited for other reasons & : member of the same patent family, corresponding document	

EPO FORM 1503 03/82 (P04/C01)

**ANNEX TO THE EUROPEAN SEARCH REPORT
ON EUROPEAN PATENT APPLICATION NO.**

EP 14 16 4143

5

This annex lists the patent family members relating to the patent documents cited in the above-mentioned European search report. The members are as contained in the European Patent Office EDP file on The European Patent Office is in no way liable for these particulars which are merely given for the purpose of information.

06-11-2014

10

Patent document cited in search report	Publication date	Patent family member(s)	Publication date
US 2005002540 A1	06-01-2005	US 6879696 B1 US 2005002540 A1	12-04-2005 06-01-2005

DE 102010041695 A1	25-08-2011	NONE	

WO 2010147554 A1	23-12-2010	EP 2443842 A1 JP 2012530448 A US 2012243717 A1 WO 2010147554 A1	25-04-2012 29-11-2012 27-09-2012 23-12-2010

15

20

25

30

35

40

45

50

55

EPO FORM P0459

For more details about this annex : see Official Journal of the European Patent Office, No. 12/82