

(19)



(11)

EP 3 577 413 B1

(12)

EUROPEAN PATENT SPECIFICATION

(45) Date of publication and mention of the grant of the patent:
20.09.2023 Bulletin 2023/38

(51) International Patent Classification (IPC):
F42B 1/02 ^(2006.01) **F42B 12/16** ^(2006.01)
F42B 15/00 ^(2006.01) **F42B 12/52** ^(2006.01)

(21) Application number: **18705815.1**

(52) Cooperative Patent Classification (CPC):
F42B 12/16; F42B 1/02; F42B 12/52; F42B 15/00

(22) Date of filing: **31.01.2018**

(86) International application number:
PCT/BG2018/000009

(87) International publication number:
WO 2018/141031 (09.08.2018 Gazette 2018/32)

(54) **CUMULATIVE THERMOBARIC WARHEAD**
 KUMULATIVER AEROSOLSPRENGKOPF
 OGIVE CUMULATIVE-THERMOBARIQUE

(84) Designated Contracting States:
AL AT BE BG CH CY CZ DE DK EE ES FI FR GB GR HR HU IE IS IT LI LT LU LV MC MK MT NL NO PL PT RO RS SE SI SK SM TR

(74) Representative: **Neykov, Neyko Hristov**
NIKOPATENT S.A.
58, Vorino Street
App. 2
1680 Sofia (BG)

(30) Priority: **31.01.2017 BG 11245017**

(43) Date of publication of application:
11.12.2019 Bulletin 2019/50

(56) References cited:
BG-U1- 1 255 BG-U1- 1 708
CZ-U1- 25 331

(73) Proprietors:
 • **Transmobil Ltd**
1517 Sofia (BG)
 • **Petkov, Stancho Petkov**
4330 Sopot (BG)

• **Anonymous: "TBG-7V round", , 30 September 2016 (2016-09-30), XP055460650, Retrieved from the Internet:
 URL:http://gunrf.ru/rg_granatomet_ps-7_TBГ-7V_eng.html [retrieved on 2018-03-19]**

(72) Inventor: **PETKOV, Stancho Petkov**
4330 Sopot (BG)

Note: Within nine months of the publication of the mention of the grant of the European patent in the European Patent Bulletin, any person may give notice to the European Patent Office of opposition to that patent, in accordance with the Implementing Regulations. Notice of opposition shall not be deemed to have been filed until the opposition fee has been paid. (Art. 99(1) European Patent Convention).

EP 3 577 413 B1

Description

FIELD OF THE INVENTION

[0001] The invention relates to a cumulative-thermobaric shot to be used in combat actions (hostilities) to destroy all types of armored and motorized transport equipment, the enemy's live force and firing equipment located in open areas, in trenches and field shelters, in brick and concrete facilities/structures.

BACKGROUND OF THE INVENTION

[0002] There are tandem warheads known to be used to defeat armored machinery and other enemy objects.

[0003] A tandem-cumulative ammunition is known, being the subject of Patent US 5 415 105, whose structure includes a housing with a primary cumulative charge fitted in it with a cumulative concavity oriented toward the front of the housing.

[0004] Patent publication DE3942841 is known, disclosing a tandem munition where the primary charge has a piezoelectric impact blower, which contains a contact/impact shock sensor, designed to generate the ignition voltage needed to ignite the detonator. The ignition voltage of the detonator occurs when, in a collision at (with) the target, the emerging shock wave triggers the contact impact sensor. In the structure described, the piezo-elements in the impact blower are used as sensors.

[0005] Patent publications, DE 114 5522 or US 289 4457, are known, related to a piezoelectric contact blower, which describe the way a piezoelectric contact blower operates. The TBG-7V is a known projectile with a thermobaric and a cumulative warhead.

[0006] There is a tandem-cumulative warhead known, subject of BG 63851 B1 patent publication, related to a tandem-cumulative warhead, the construction of which comprises of a composite housing, hosting the forearm and the primary warhead, with two co-axial cumulative charges comprising two autonomous, not inter-dependent piezoelectric explosive devices, located in the inner space of the housing of the cumulative warhead; the rear end of the housing has a drive mechanism connected to it - the mechanism has a motor and starting gunpowder charge and stabilizers.

[0007] The disadvantage of the invention is the small distance between the forearm and the primary warhead, as a result of which the detonation products of the forearm have a significant, dominant influence on the time and the manner of forming the cumulative jet flow (spurt) caused by the actuation of the primary cumulative charge.

SUMMARY OF THE INVENTION

[0008] Given the state - described and known - of the equipment in the area under consideration, the utility model's task is to provide/offer a cumulative-thermobaric

shot of simplified and production-related technology construction, an increased range of shooting and of better accuracy when hitting the targets, by ensuring effective destruction of all types of armored and motorized transport equipment, the enemy's live force (soldiers) and firing equipment located in open areas, trenches and concealments of field-like type or in brick and concrete structures.

[0009] The problem is solved by a cumulative-thermobaric shot according to claim 1, which includes a composite housing comprising of fairing and a cumulative warhead located behind it, with a piezoelectric generator located in the inner space of the warhead housing; the piezoelectric generator is electrically connected to the bottom blasting device of the cumulative warhead, and an actuator consisting of a jet engine and a starter gunpowder charge with stabilizers is mounted to the rear end of the warhead housing.

[0010] According to the invention, the cumulative and thermobaric warheads are located together in the composite housing; and the cumulative warhead is rigidly connected by a coupling bushing to the coupling cone and mounted in the inner space of the thermobaric warhead to the bottom of which the jet engine is connected to, while the piezoelectric generator is connected to a current-conducting element located in the coupling cone. A sealing plug located in the inner space of the thermobaric warhead is rigidly mounted at the rear end of the cumulative warhead.

[0011] According to a preferred execution of the cumulative-thermobaric shot, the cumulative warhead is located coaxially inside the thermobaric warhead.

[0012] According to an execution of the cumulative-thermobaric shot, the coupling bushing is formed gradually, in a cylindrical form, and the fairing, the housing of the cumulative warhead and the coupling cone of the thermobaric warhead are rigidly fixed to it.

[0013] According to a preferred execution of the cumulative-thermobaric shot, the conducting element has a conical shape; the fairing and the coupling cone are rigidly fixed to the coupling bushing at the rear end of which the cumulative warhead is rigidly mounted to.

[0014] The cumulative-thermobaric warhead consists of a housing, a coupling cone and a fairing, all coupled in one by a coupling bushing, and a threaded opening is formed in front of the fairing, and the piezoelectric generator of the bottom blasting device is mounted to it - connected by the means of a electricity-conducting element located in the internal space of the fairing and the coupling cone, and a cumulative unit (consisting of a cumulative funnel with a conductor with an opening angle of 60° and with a variable wall thickness progressively increasing from the top to the base) is air-tightly mounted in the rear part of the coupling bushing. The internal volume of the thermobaric warhead includes a conical-spherical screen made of inert material mounted behind the cumulative funnel, pressed together into the explosive substance.

[0015] According to a preferred execution of the invention, the cumulative-thermobaric warhead is suitable to be filled with a caliber of not more than 105 mm, while the cumulative warhead has a caliber of not more than 60 mm.

[0016] The cumulative-thermobaric shot has significant advantages in terms of simplified technological design (construction) and improved effectiveness in terms of target hitting. Incorporating the cumulative unit in the thermobaric warhead, on the one hand, enables the cumulative unit to be used as the trigger element for the thermobaric mix from the thermobaric - when the shot encounters with the hit target, and on the other hand, it constructively provides a double - cumulative and thermobaric - action when hitting the targets.

[0017] The so described allocation/setting of the cumulative warhead with a front-bottom piezoelectric generator, a piezoelectric blasting device in its essence, provides instantaneous contact action when hitting/meeting with the target, while the detonation products of the cumulative unit initiate the thermobaric mix, resulting in the creation of a thermobaric effect of an area of high pressure and high temperature in the area of operation.

[0018] These technical effects are due to a considerable extent to the predicted constructive bond between the cumulative and the thermobaric warheads by means of the coupling bushing whose bond is suitable to be rigid. These qualities of it allow it to bear the deformation effects of the contact action when encountering with the target and at the same time to generate an electrical impulse from the piezoelectric generator and to launch the bottom explosive device; the formed detonation pulse on the one hand forms a cumulative airflow from the cumulative warhead, and from the other side, it detonates the thermobaric mix, located in the space between the housing of the cumulative warhead and the inner space of the housing of the thermobaric warhead.

[0019] According to the invention, another advantage of the cumulative-thermobaric shot is related to the improved aerodynamic parameters of the structure whose stabilization on the trajectory is mainly due to the rigid connection between the housing of the thermobaric warhead to the jet engine and the starter gunpowder charge with the stabilizers.

[0020] The starter gunpowder motor with stabilizers launches (shoots) the cumulative-thermobaric shot from a grenade launcher under the influence of a dynamo-reactive force, whereby, thanks to the stabilizer located at the rear part of the shot, the flight gets stabilized along its trajectory through the resulting stabilizing torque and the angular speed, while the jet engine accelerates the shot during (in) the active stretch of the trajectory.

[0021] A high degree of airtightness of the cumulative unit and of the thermobaric warhead as a whole is constructively provided in the proposed cumulative-thermobaric warhead, thus achieving effective functionality as well as the intended/provided usage and utilization.

DESCRIPTION OF THE DRAWINGS

[0022] Further in the description, a detailed example of execution/making of a cumulative-thermobaric shot is presented - according to the invention, illustrated by the accompanying drawings, wherein:

Fig.1 - general view of the cumulative-thermobaric shot, subject of the invention.

Fig.2 - general view of the cumulative-thermobaric shot in flight mode.

Fig.3 - general view with a partial section of the cumulative-thermobaric warhead.

15 PRIMERY ENBODIMENT OF THE INVENTION

[0023] The cumulative-thermobaric shot - according to the invention - consists of a cumulative-thermobaric warhead (1), and an actuator (drive) unit is connected to the rear part of it. The unit consists of a jet engine (2) and a starter gunpowder engine (3) connected to it, comprising of a stabilizer (Figures 1, 2).

[0024] The cumulative-thermobaric warhead (1) has been made as a compound housing, comprising of a fairing (8) located in the front part, and a cumulative warhead (5) is located behind it. The warhead (5) is mounted - using a coupling bushing (18) to a coupling cone (16), while the bushing (18) is located in the inner space of the conical-cylindrical housing of the thermobaric warhead (15), and the jet engine 2 is connected to the bottom part of it (15).

[0025] The coupling bushing (18) has been made gradually, having a cylindrical shape at various levels, made with inner and outer threading - respectively. In its essence, this is a connecting element between the cumulative warhead (5), the coupling cone (16) and the housing of the thermobaric warhead (15). The coupling cone (16) is rigidly connected to the housing, made in a cylindrical-conical shape, and the cumulative warhead (5) is located in its inner space. Such a construction forming of the coupling bushing (18) allows the forming of a rigid, firm connection between the aforesaid elements, and at time of shot they are burdened and carry the dynamic deformation effects when encountering with the cumulative-thermobaric shot with the target.

[0026] The threading units in the construction of the cumulative-thermobaric warhead have been designed in a way to provide airtightness of the units and the construction as a whole - by means of sealing rings.

[0027] According to a preferred execution of the invention, the cumulative warhead (5) has been made in a caliber of up to 60 mm and consists of a piezoelectric generator (6) (located in its frontal part), connected to a current-conducting element (9) located in the fairing (8) and the coupling cone (16). It is preferable, if the current-conducting element (9) and the fairing (8) have a conical shape (Figure 3). The fairing (8) is rigidly connected to the coupling bushing (18), and the housing of the ther-

mobaric warhead (15) is mounted to it - and a cumulative unit (comprising of a cumulative funnel (4) with a conductor and a screen (11), pressed within the explosive substance is located in its inner space. The cumulative funnel (4) has been made with a variable wall thickness progressively increasing from the top to the base, and the screen (11) is located behind it. The screen (11) is symmetrically pressed in the explosive substance. The bottom blasting device (7) is mounted behind the screen (11), while the sealing plug (14) is mounted at the rear part of the cumulative warhead (5), providing the necessary airtightness of the cumulative warhead (5) in regards to the thermobaric mix (17), located in the thermobaric warhead (15), closed in its rear part by an airtight plug (19).

[0028] In the explosive substance of the cumulative unit, the screen (11) is located between the cumulative funnel with the conductor (4) and the detonator of the bottom blasting device (7). The geometrical parameters and the conical-spherical shape of the screen (11) have taken into consideration its functional purpose of use, and in combination with the configuration of the cumulative funnel with the conductor (4), the housing, the type of the explosive substance, its energy/power parameters and their mutual location, it deforms and manages the front of the detonation wave, formed by the detonation of the explosive substance, thus forming a cumulative airflow of certain geometrical and energy/power parameters.

[0029] The screen (11) is suitably to be made of an inert material with the option (possibility) of deformation; its purpose of use is to change and manage the front of the detonation wave, formed with the launch of the explosive substance. In this case, the so formed front of the detonation wave is similar closely to the parallel of the profile of the outer one formed by the cumulative funnel with the conductor (4), and dynamically deforming it, thus enhances the forming of a cumulative airflow from the cumulative warhead (5) of certain kinetic and energy/power parameters; and in parallel to this, it detonates the thermobaric mix (17) - at the place of contact an area of high pressure and high temperature is formed.

[0030] The cumulative-thermobaric warhead (1) should preferably have a caliber not larger than 105 mm, while the cumulative warhead (5) is made with a caliber of up to 60 mm. It is preferable to use explosive substance, characterized with density of (from) 1.76 to 1.8 g/cm³ and detonation speed of not less than 8000 m/s. The bulletproofness of the cumulative warhead 4 on a homogeneous armored steel is not less than 300 mm.

OPERATION OF THE INVENTION

[0031] The use of the described cumulative-thermobaric shot may be presented the following way: after placing the cumulative-thermobaric shot in the grenade launcher and producing a shot, a dynamo-reactive force is created as a result of the gases generated by the gun-

powder starter engine (3). This force drives the cumulative-thermobaric shot forward in the direction of the target. Upon having the cumulative-thermobaric shot take-off from the grenade launcher - under the operation of the gunpowder gases and the formed reactive force - a rotary motion with an angular velocity of 7...8 turns/sec. and an initial take-off speed from the grenade launcher mouth of not less than 70 m/s is transmitted to the shot. When running forward, under the operation of the reactive force, linear-inertial forces arise by activating the inertial mechanism of the pyro-delayer of the jet engine (2). In parallel to it, the inertia mechanisms of the bottom blasting device (7) of the cumulative thermobaric warhead (1) are activated.

[0032] After the shot takes off from the grenade launcher, the four feathers of the stabilizer are opened by the operation of the centrifugal forces and countercurrent airflow. The inertial and pyrotechnical safe mechanisms of the bottom blasting device (7) of the cumulative warhead (5) end approximately by the 12th meter from the start of the shot trajectory, resulting in the cumulative-thermobaric shot being ready to meet/hit the target.

[0033] In the starting section of the shot trajectory, the pyro-delay ignition device of the jet engine (2) is triggered, and as a result of the reactive force thus created, the shot accelerates and reaches a maximum speed in the active area of its trajectory of approximately 70...80 meters from the launch and having the shot reach the target and the cumulative-thermobaric warhead 1 hit it (the target).

[0034] The operation of the jet engine (2) is approximately 0.7...074 s in a temperature range of - 50°C to + 50°C. When observing these parameters, one has a straight shot provided at a distance of not less than 250 m.

[0035] When the cumulative-thermobaric shot meets with the barrier, the piezoelectric generator (6) of the cumulative warhead (5) generates an electrical impulse which over an electric circuit (a conductive cone (9), a cumulative funnel with a conductor (4), upper contact of the bottom blasting device (7) on the one hand, and on the other, the chain consists of the fairing (8), the coupling bushing (18), the housing of the cumulative warhead and a pressing nut of the bottom blasting device (7), not shown in the figures, and the housing of the bottom blasting device (7), is transmitted to a spark electric detonator (not shown in the figures) of the bottom blasting device (7) and then a detonating impulse is transmitted to the explosive substance of the cumulative charge.

[0036] The thus-formed spherical front of the detonation wave is spread along the bursting charge, perambulating the conical-spherical shape of the screen (11), thereby altering its shape and parameters. The formed new front of the detonation wave front fits (perambulates) quite closely to the profile of the cumulative funnel (4) by dynamically deforming it and forming a cumulative airflow. The formed cumulative airflow interacts with the barrier and breaks it through. Parallel to this, the released from the detonation products of the cumulative warhead (5) energy detonates the thermobaric mix (17) contained

in the housing. A high pressure and temperature front is formed in the area of operation as part of the thermobaric effect penetrates through the opening created by the cumulative warhead (5) when interacting with the target. The remaining part affects the outer area of the target thus creating double cumulative-thermobaric action.

[0037] The delaying action of the thermobaric effect on the cumulative action of the cumulative warhead (5) is determined by the differences in the speeds of the running processes, the cumulative airflow being formed at a speed in the range of 10... 12 km/s, while the formed detonation wave front for initiation of the thermobaric mix from the detonation of the bottom blasting device (7) and the explosive substance spreads with a detonation speed of 7.6...8 km/s.

Legend:

[0038]

- 1- Cumulative thermobaric warhead
- 2- Jet engine
- 3- Gunpowder starting engine
- 4- Stabilizer
- 5- Cumulative warhead
- 6- Piezoelectric generator
- 7- Bottom blasting device
- 8- Fairing
- 9- Current-conducting conical element
- 11 - Screen
- 13 - Blasting device
- 14 - Sealing plug of the cumulative warhead
- 15 - Thermobaric warhead
- 16 - Coupling cone
- 17 - Thermobaric mixture
- 18 - Coupling bushing
- 19 - Airtight plug of the thermobaric warhead

Claims

1. Cumulative-thermobaric shot, consisting of a compound housing having a fairing (8), a thermobaric warhead (15) and a cumulative warhead (5) with a piezo-electrical bottom blasting device (7) located behind the cumulative warhead (5), said cumulative warhead (5) and said piezo-electrical bottom blasting device (7) being placed in an internal space of a housing of the aforesaid warhead, whereby a piezo-electric generator (6) is electrically connected to the bottom blasting device (7) of the cumulative warhead (5), and an actuator is mounted at the rear end of the compound housing, whereby the actuator is comprised of a jet engine (2) and a starter gunpowder charge (3) with a stabilizer, whereby the compound

housing is home to the cumulative (5) and a thermobaric (15) warhead, whereby the cumulative warhead (5) is rigidly connected through a coupling bushing (18) to a coupling cone (16) and is mounted in an internal space of the thermobaric warhead (15), at the bottom part of the thermobaric warhead (15) the jet engine (2) is connected to, whereby the piezoelectric generator (6) is connected to a current-conducting element (9) located in the coupling cone (16), whereby a sealing plug (14) is located in the internal space of the thermobaric warhead (15) and is rigidly mounted at the rear end of the cumulative warhead (5).

2. Cumulative-thermobaric shot according to claim 1, **characterized by** the fact that the cumulative warhead (5) is co-axially located in the inner part of the housing of the thermobaric warhead (15) which is filled with thermobaric mix (17).

3. Cumulative-thermobaric shot according to claim 1, **characterized by** the fact that the coupling bushing (18) has been made gradually, having a cylindrical shape; and the following are rigidly connected to it: the fairing (8), the housing of the cumulative warhead (5) and the coupling cone (16) of the thermobaric warhead (15).

4. Cumulative-thermobaric shot according to claim 1, **characterized by** the fact that the current-conducting element (9) has a conical shape, and the fairing (8) and the coupling cone (16) are rigidly connected to the coupling bushing (18), and the cumulative warhead (5) is rigidly mounted to the rear end of it.

5. Cumulative-thermobaric shot according to claim 1, **characterized by** the fact that the cumulative-thermobaric warhead (1) comprises the housing, the coupling cone (16) and the fairing (8), connected all in one by means of the coupling bushing (18), wherein inside the fairing (8), there is a threaded opening and the piezoelectric generator (6) of the bottom blasting device (7) is mounted to it, connected by means of the current-conducting element (9) located in the internal space of the fairing (8) and the coupling cone (16), while at the back side of the coupling bushing (18), the cumulative warhead (5) is air-tightly mounted in the rear part, wherein the cumulative warhead (5) comprises a cumulative funnel conductor (4) with an opening angle of 60° and with a variable wall thickness progressively increasing from the top to the base.

6. Cumulative-thermobaric shot according to claim 1, **characterized by** the fact that the cumulative-thermobaric warhead (1) has a caliber no larger than 105 mm, while the cumulative warhead (5) has a caliber no larger than 60 mm.

Patentansprüche

1. Kumulativer aerosolsprengkopf, bestehend aus einem Verbundgehäuse mit einer Verkleidung (8), einem thermobaren Gefechtskopf (15) und einem kumulativen Gefechtskopf (5) mit einer piezoelektrischen Bodensprengvorrichtung (7), die hinter dem kumulativen Gefechtskopf (5) angeordnet ist, wobei der besagte kumulative Gefechtskopf (5) und die besagte piezoelektrische Bodensprengvorrichtung (7) in einem Innenraum eines Gehäuses des vorgenannten Gefechtskopfes angeordnet sind, wobei ein piezoelektrischer Generator (6) elektrisch mit der Bodensprengvorrichtung (7) des kumulativen Gefechtskopfes (5) verbunden ist und am hinteren Ende des Verbundgehäuses ein Antrieb angebracht ist, wobei der Antrieb aus einem Strahltriebwerk (2) und einer Schießpulver-Startladung (3) mit einem Stabilisator besteht, wobei in dem Verbundgehäuse der kumulative (5) und der thermobare (15) Gefechtskopf untergebracht sind, wobei der kumulative Gefechtskopf (5) über eine Kupplungsbuchse (18) starr mit dem Kupplungskonus (16) verbunden ist und in einem Innenraum des thermobaren Gefechtskopfes (15) angebracht ist, mit dessen unterem Teil das Strahltriebwerk (2) verbunden ist, wobei der piezoelektrische Generator (6) mit dem stromleitenden Element (9) im Kupplungskonus (16) verbunden ist, wobei sich im Innenraum des thermobaren Gefechtskopfes (15) ein Dichtstopfen (14) befindet, der starr am hinteren Ende des kumulativen Gefechtskopfes (5) angebracht ist.
2. Kumulativer aerosolsprengkopf nach Anspruch 1, **dadurch gekennzeichnet, dass** der kumulative Gefechtskopf (5) koaxial im Inneren des Gehäuses des thermobaren Gefechtskopfes (15) angeordnet ist, der mit einem thermobaren Gemisch (17) befüllt ist.
3. Kumulativer aerosolsprengkopf nach Anspruch 1, **dadurch gekennzeichnet, dass** die Kupplungsbuchse (18) eine abgestufte Zylinderform mit sich verjüngenden Durchmessern hat und dass die folgenden Komponenten starr damit verbunden sind: die Verkleidung (8), das Gehäuse des kumulativen Gefechtskopfes (5) und der Kupplungskonus (16) des thermobaren Gefechtskopfes (15).
4. Kumulativer aerosolsprengkopf nach Anspruch 1, **dadurch gekennzeichnet, dass** das stromleitende Element (9) kegelförmig ist und die Verkleidung (8) und der Kupplungskonus (16) starr mit der Kupplungsbuchse (18) verbunden sind und der kumulative Gefechtskopf (5) starr am hinteren Ende der Kupplungsbuchse angebracht ist.
5. Kumulativer aerosolsprengkopf nach Anspruch 1,

dadurch gekennzeichnet, dass der kumulativ-thermobare Gefechtskopf (1) einen Kupplungskonus (16) und eine Verkleidung (8) umfasst, die sämtlich über die Kupplungsbuchse (18) miteinander verbunden sind, wobei sich in der Verkleidung (8) eine Gewindebohrung befindet und der piezoelektrische Generator (6) der Boden-Sprengvorrichtung (7) daran angebracht ist und über das stromleitende Element (9) im Innenraum der Verkleidung (8) und des Kupplungskonus (16) angeschlossen ist, während auf der Rückseite der Kupplungsbuchse (18) im hinteren Teil eine kumulative Einheit luftdicht angebracht ist, die einen kumulativen Trichter (4) mit einem Öffnungswinkel von 60° und einer variablen Wanddicke, die von der Spitze zur Basis schrittweise zunimmt, umfasst.

6. Kumulativer aerosolsprengkopf nach Anspruch 1, **dadurch gekennzeichnet, dass** der kumulativ-thermobare Gefechtskopf (1) ein Kaliber von höchstens 105 mm aufweist, während der kumulative Gefechtskopf (5) ein Kaliber von höchstens 60 mm aufweist.

Revendications

1. Ogive cumulative-thermobarique, consistant en un boîtier composé, ayant un carénage (8), une ogive thermobarique (15) et une ogive cumulative (5) avec un dispositif piézo-électrique de grenailage de fond (7), situé derrière l'ogive cumulative (5), ladite ogive cumulative (5) et ledit dispositif piézo-électrique de grenailage de fond (7) étant placés dans un espace interne d'un boîtier de l'ogive susmentionnée, un générateur piézoélectrique (6) est connecté électriquement au dispositif de grenailage de fond (7) de l'ogive cumulative (5), et un actionneur est monté à l'extrémité arrière du boîtier composé, l'actionneur étant composé d'un moteur à réaction (2) et d'une charge de poudre à canon de démarrage (3) avec un stabilisateur, l'ogive cumulative (5) est rigidement reliée au cône d'accouplement (16) par une douille d'accouplement (18) et est montée dans un espace interne de l'ogive thermobarique (15), à la partie inférieure de laquelle le moteur à réaction (2) est relié, le générateur piézoélectrique (6) est relié à l'élément conducteur de courant (9) situé dans le cône d'accouplement (16), un bouchon d'étanchéité (14) est situé dans l'espace interne de l'ogive thermobarique (15) et est monté rigidement à l'extrémité arrière de l'ogive cumulative (5).
2. Ogive cumulative-thermobarique selon la revendication 1, **caractérisé par le fait que** l'ogive cumulative (5) est située coaxialement dans la partie intérieure du boîtier de l'ogive thermobarique (15), qui est remplie de mélange thermobarique (17).

3. Ogive cumulative-thermobarique selon la revendication 1, **caractérisé par le fait que** la douille d'accouplement (18) a été conçue avec mesurages successifs, qu'elle a une forme cylindrique et que les éléments suivants lui sont rigidement reliés : le carénage (8), le boîtier de l'ogive cumulative (5) et le cône d'accouplement (16) de l'ogive thermobarique (15). 5
4. Ogive cumulative-thermobarique selon la revendication 1, **caractérisé par le fait que** l'élément conducteur de courant (9) a une forme conique, que le carénage (8) et le cône d'accouplement (16) sont rigidement reliés à la douille d'accouplement (18) et que l'ogive cumulative (5) est rigidement montée à l'extrémité arrière de celle-ci. 10 15
5. Ogive cumulative-thermobarique selon la revendication 1, **caractérisé par le fait que** l'ogive thermobarique cumulative (1) comprend un cône d'accouplement (16) et un carénage (8), reliés tous ensemble au moyen d'une douille d'accouplement (18), dans laquelle se trouve une ouverture filetée à l'intérieur du carénage (8) et sur laquelle est monté le générateur piézoélectrique (6) du dispositif de grenailage de fond (7), connecté au moyen d'un élément conducteur de courant (9) situé dans l'espace interne du carénage (8) et du cône d'accouplement (16), tandis qu'à l'arrière de la douille d'accouplement (18), un dispositif cumulatif est monté de manière étanche à l'air dans la partie arrière, qui comprend un entonnoir cumulatif (4) avec un angle d'ouverture de 60° et une épaisseur de paroi variable augmentant progressivement du haut vers la base. 20 25 30 35
6. Ogive cumulative-thermobarique selon la revendication 1, **caractérisé par le fait que** l'ogive thermobarique cumulative (1) a un calibre ne dépassant pas 105 mm, tandis que l'ogive cumulative (5) a un calibre ne dépassant pas 60 mm. 40

45

50

55

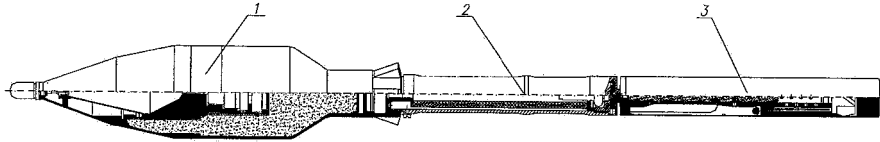

Fig. 1

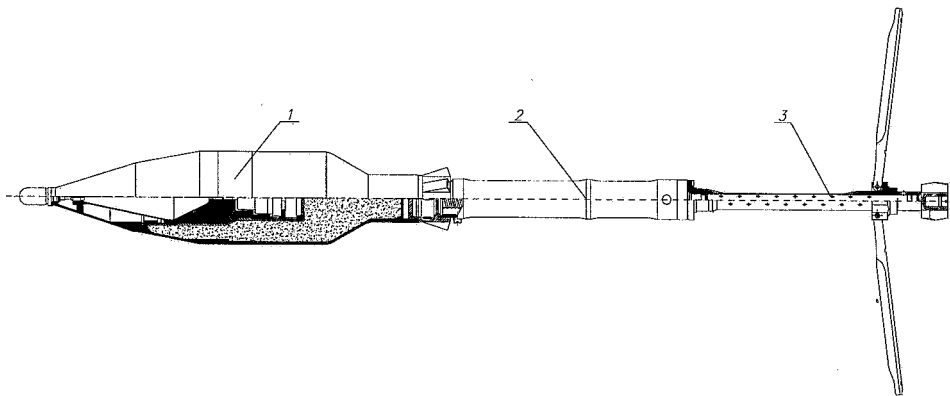

Fig. 2

Amended Figure 3

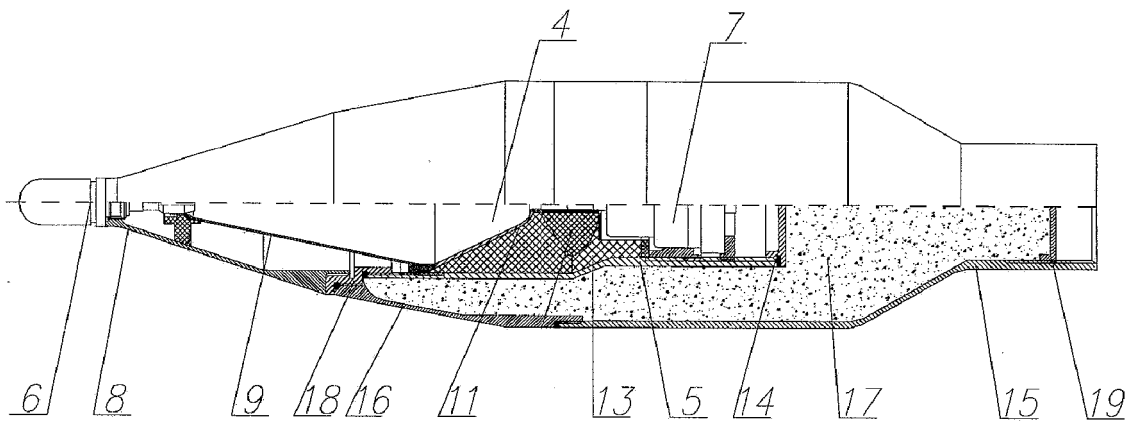

Fig. 3

REFERENCES CITED IN THE DESCRIPTION

This list of references cited by the applicant is for the reader's convenience only. It does not form part of the European patent document. Even though great care has been taken in compiling the references, errors or omissions cannot be excluded and the EPO disclaims all liability in this regard.

Patent documents cited in the description

- US 5415105 A [0003]
- DE 3942841 [0004]
- DE 1145522 [0005]
- US 2894457 A [0005]
- BG 63851 B1 [0006]