



US011429037B2

(12) **United States Patent**
Haruyama

(10) **Patent No.:** **US 11,429,037 B2**

(45) **Date of Patent:** **Aug. 30, 2022**

(54) **DEVELOPER CONTAINER AND IMAGE FORMING APPARATUS HAVING DEVELOPER OUTLET FOR DISCHARGING DEVELOPER**

15/0891; G03G 15/0879; G03G 15/0877; G03G 2215/0668; G03G 2215/068; G03G 2215/0802; G03G 2215/0822; G03G 2215/085

See application file for complete search history.

(71) Applicant: **Oki Electric Industry Co., Ltd.**, Tokyo (JP)

(56) **References Cited**

(72) Inventor: **Hiroki Haruyama**, Tokyo (JP)

U.S. PATENT DOCUMENTS

(73) Assignee: **Oki Electric Industry Co., Ltd.**, Tokyo (JP)

5,652,944 A * 7/1997 Masuda G03G 15/32 399/24
2011/0052268 A1* 3/2011 Mano G03G 15/0877 399/262
2015/0301481 A1 10/2015 Okuda

(*) Notice: Subject to any disclaimer, the term of this patent is extended or adjusted under 35 U.S.C. 154(b) by 0 days.

FOREIGN PATENT DOCUMENTS

(21) Appl. No.: **17/406,638**

EP 3255497 A1 12/2017
JP 2016194623 A 11/2016
JP 2020071405 A 5/2020

(22) Filed: **Aug. 19, 2021**

* cited by examiner

(65) **Prior Publication Data**

US 2022/0128927 A1 Apr. 28, 2022

Primary Examiner — Walter L Lindsay, Jr.

Assistant Examiner — Laura Roth

(74) *Attorney, Agent, or Firm* — Rabin & Berdo, P.C.

(30) **Foreign Application Priority Data**

Oct. 23, 2020 (JP) JP2020-178155

(57) **ABSTRACT**

A developer container includes: a case that stores developer and in which a developer outlet for discharging the developer is formed; a conveying spiral that is rotatably disposed in the case and rotates to convey the developer toward the developer outlet in an axial direction of the conveying spiral; a guide wall that is disposed along the conveying spiral and guides the developer in the axial direction of the conveying spiral; and a push member that is attached to the conveying spiral and rotates with the conveying spiral to push the developer into the developer outlet. A cutout is formed at a portion of the guide wall corresponding to the push member to form a guide portion that guides the developer to the developer outlet.

(51) **Int. Cl.**
G03G 15/08 (2006.01)

(52) **U.S. Cl.**
CPC **G03G 15/087** (2013.01); **G03G 15/0877** (2013.01); **G03G 15/0881** (2013.01); **G03G 15/0891** (2013.01); **G03G 2215/068** (2013.01); **G03G 2215/0668** (2013.01); **G03G 2215/085** (2013.01); **G03G 2215/0822** (2013.01)

(58) **Field of Classification Search**
CPC G03G 15/087; G03G 15/0881; G03G

8 Claims, 5 Drawing Sheets

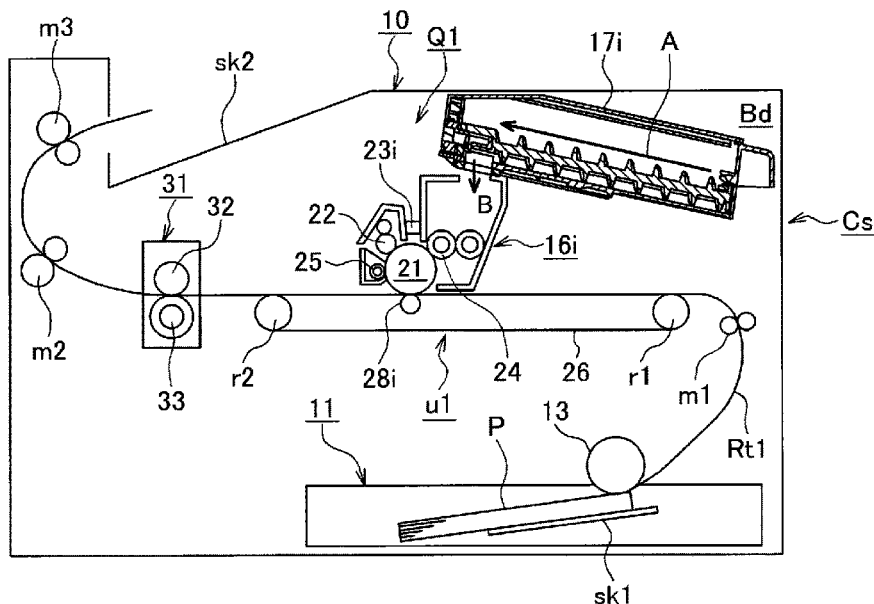

FIG. 1

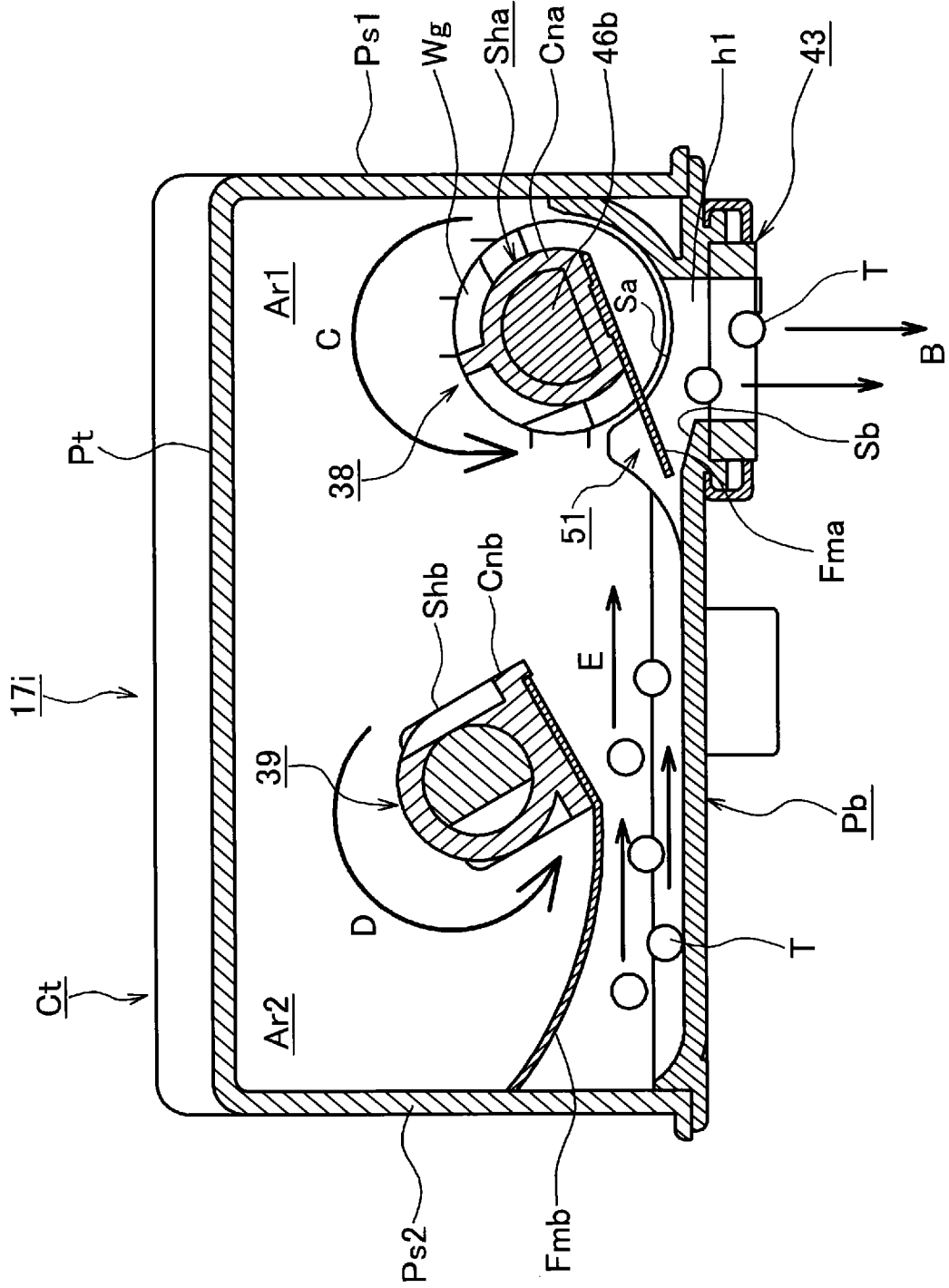

FIG. 3

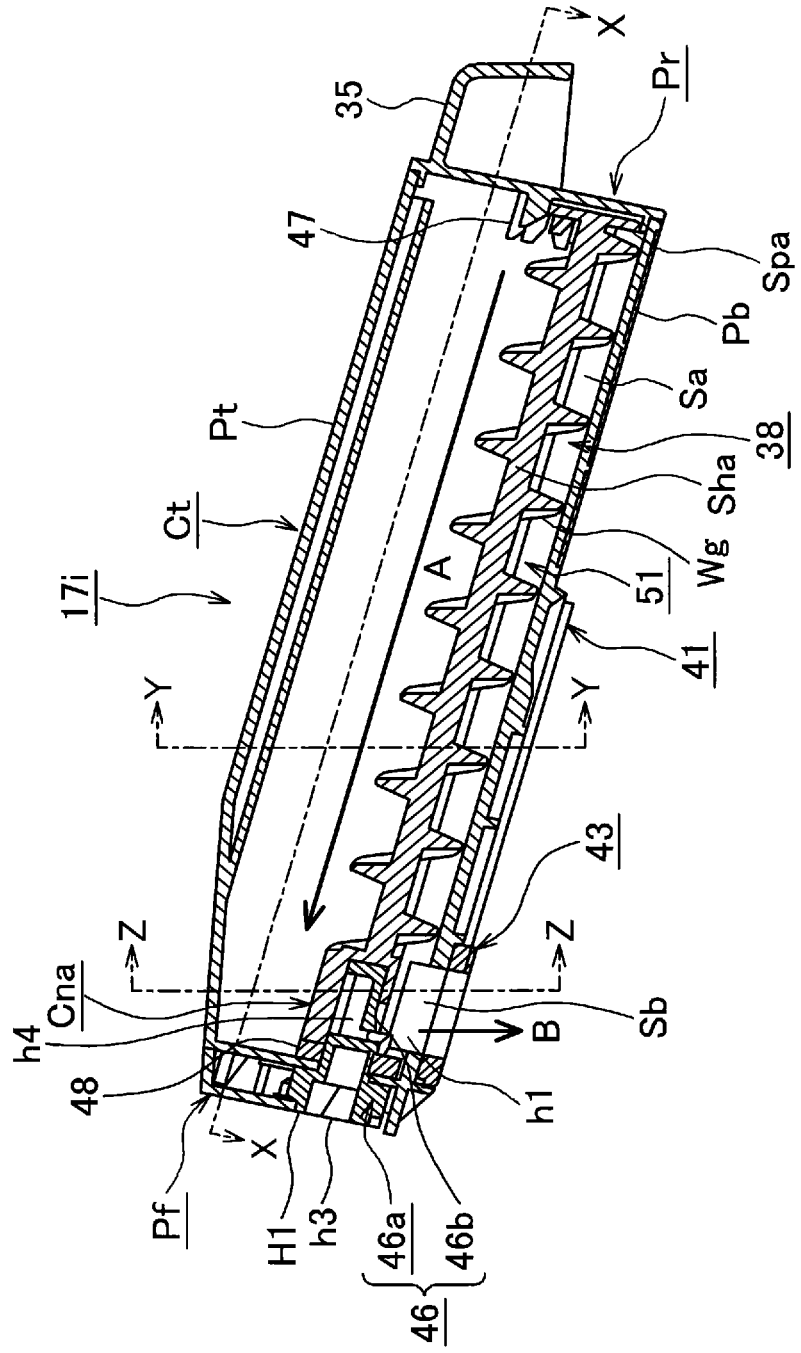

FIG. 4

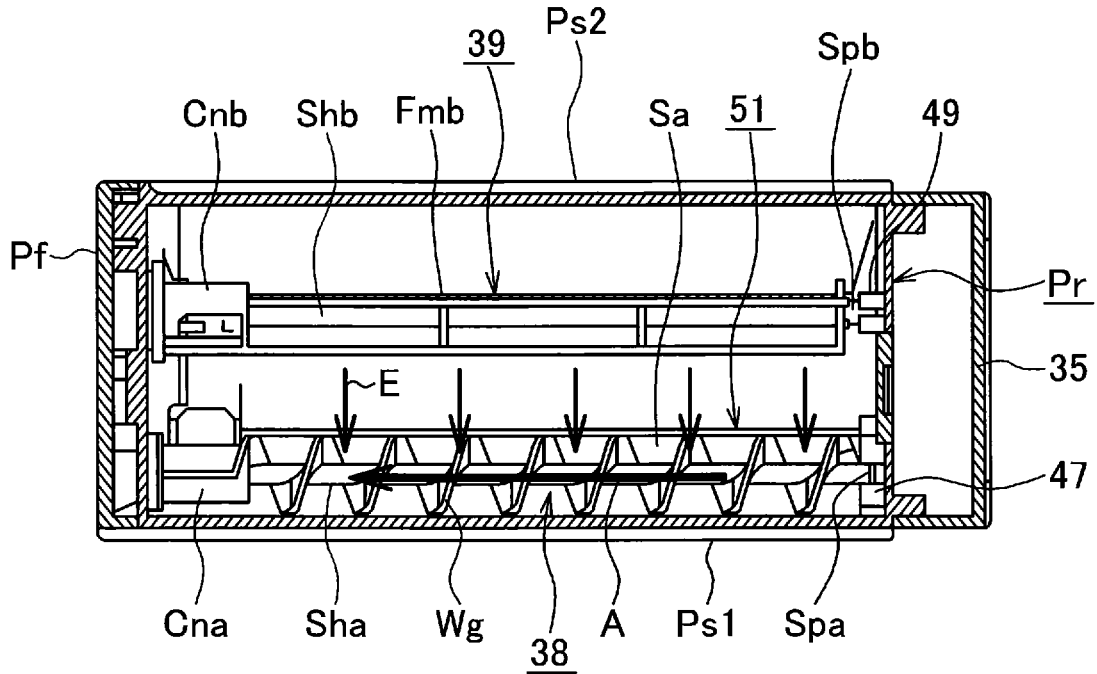

FIG. 5

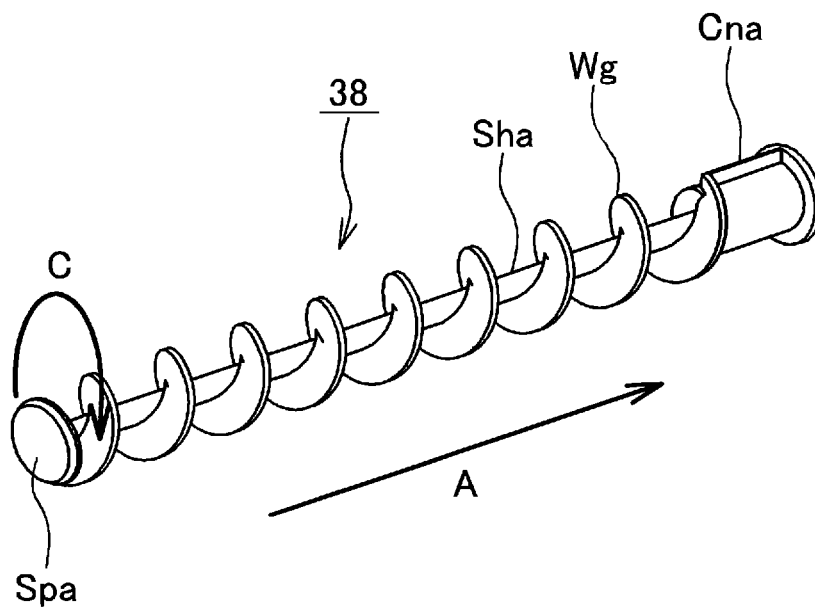
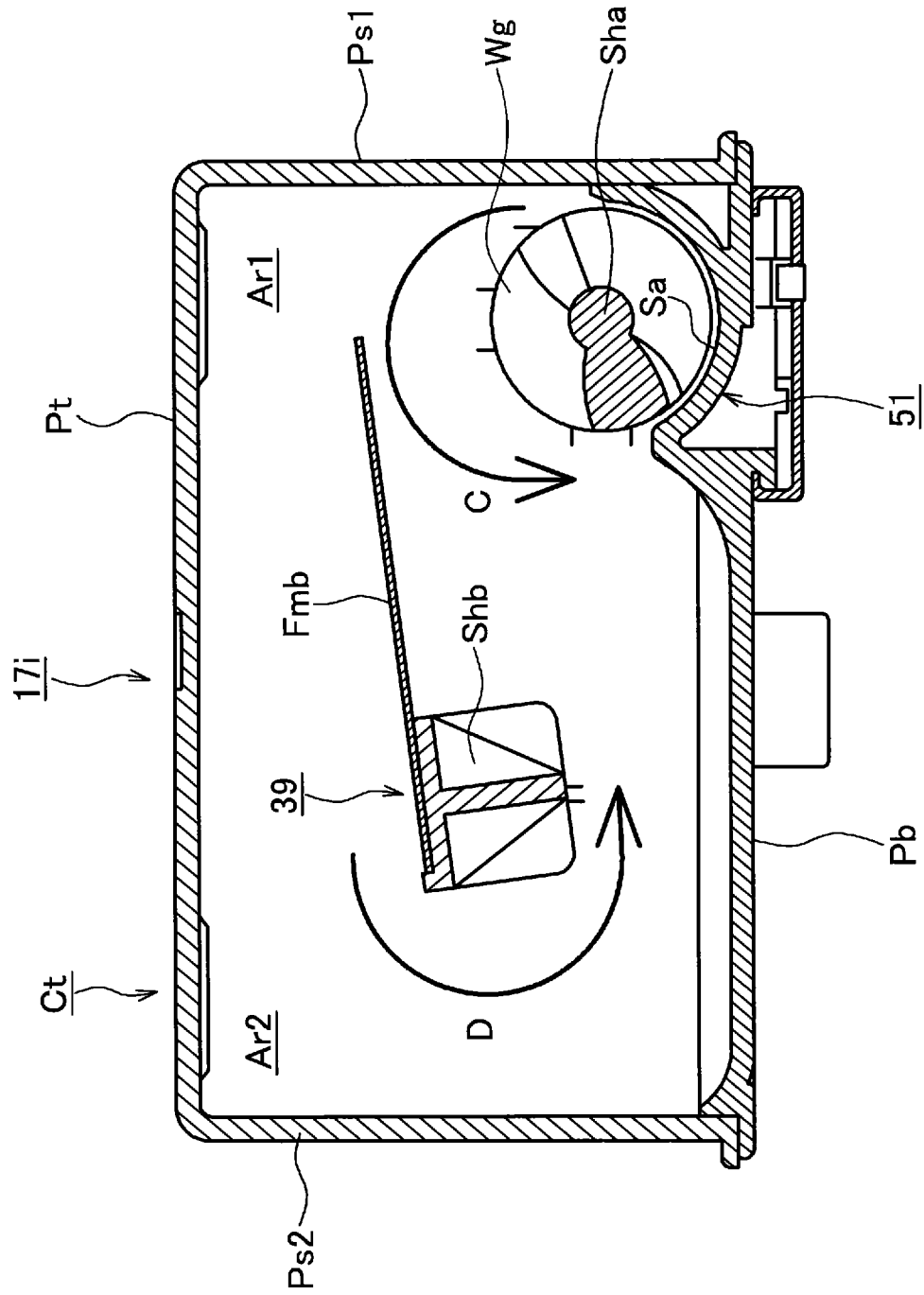

FIG. 6



**DEVELOPER CONTAINER AND IMAGE
FORMING APPARATUS HAVING
DEVELOPER OUTLET FOR DISCHARGING
DEVELOPER**

BACKGROUND OF THE INVENTION

1. Field of the Invention

Embodiments of the present invention relate to a developer container and an image forming apparatus.

2. Description of the Related Art

Conventionally, there is an image forming apparatus, such as a printer, a copier, a facsimile machine, or a multi-function peripheral, in which an image forming unit is disposed, and that prints an image by uniformly charging a surface of a photosensitive drum with a charging roller, exposing the charged surface with an LED head to form an electrostatic latent image, developing the electrostatic latent image with toner as developer supplied from a toner container as a developer container to form a toner image, and transferring the toner image onto a paper sheet with a transfer roller, in the image forming unit, and fixing the toner image to the paper sheet with a fixing unit.

There has been provided a toner container in which a screw is rotated by driving force transmitted from a predetermined driving source in a printer to convey toner. In the toner container, as the screw is rotated, toner is conveyed toward a toner outlet formed in a bottom surface of the toner container (see, e.g., Japanese Patent Application Publication No. 2020-71405).

SUMMARY OF THE INVENTION

An object of an embodiment of the present invention is to provide a developer container and an image forming apparatus capable of smoothly discharging developer.

According to an embodiment of the present invention, there is provided a developer container including: a case that stores developer and in which a developer outlet for discharging the developer is formed; a conveying spiral that is rotatably disposed in the case and rotates to convey the developer toward the developer outlet in an axial direction of the conveying spiral; a guide wall that is disposed along the conveying spiral and guides the developer in the axial direction of the conveying spiral; and a push member that is attached to the conveying spiral and rotates with the conveying spiral to push the developer into the developer outlet, wherein a cutout is formed at a portion of the guide wall corresponding to the push member to form a guide portion that guides the developer to the developer outlet.

BRIEF DESCRIPTION OF THE DRAWINGS

In the attached drawings:

FIG. 1 is a transverse sectional view of a toner container of an embodiment of the present invention;

FIG. 2 is a conceptual diagram of a printer of the embodiment of the present invention;

FIG. 3 is a longitudinal sectional view of the toner container of the embodiment of the present invention;

FIG. 4 is a sectional view taken along line X-X of FIG. 3;

FIG. 5 is a perspective view of a screw of the embodiment of the present invention; and

FIG. 6 is a sectional view taken along line Y-Y of FIG. 3.

DETAILED DESCRIPTION OF THE
INVENTION

Embodiments of the present invention will be described below with reference to the drawings. Here, a printer will be described as an example of an image forming apparatus.

FIG. 2 is a conceptual diagram of a printer 10 of an embodiment of the present invention.

In FIG. 2, the printer 10 includes a main body (or apparatus main body) Bd including a case Cs that is an exterior of the printer 10.

A sheet cassette 11 as a medium container is disposed in a lower portion of the apparatus main body Bd, and sheets (e.g., paper sheets) P as media are stored in the sheet cassette 11 in such a manner as to be stacked on a stacker sk1. Also, a hopping roller 13 as a feed member is disposed at a front end portion of the sheet cassette 11. The sheets P in the sheet cassette 11 are separated and fed one by one to a sheet conveying path Rt1 as a medium conveying path by rotating the hopping roller 13. The fed sheet P is conveyed on the sheet conveying path Rt1 by a pair of sheet feed rollers m1 as a first conveying member, and fed to an image forming portion Q1 disposed downstream of the pair of sheet feed rollers m1.

The image forming portion Q1 is constituted by image forming units 16i (i=1, 2, . . . , 4) for multiple colors, e.g., four colors of black, yellow, magenta, and cyan, toner containers 17i (i=1, 2, . . . , 4) as developer containers that store toners as developers of the respective colors and supply them to the respective image forming units 16i, LED heads 23i (i=1, 2, . . . , 4) as exposure devices, a transfer unit u1, and the like. Each toner container 17i conveys toner in the direction of arrow A and then discharges it in the direction of arrow B to supply it to the image forming unit 16i.

Each image forming unit 16i includes a photosensitive drum 21 as an image carrier, a charging roller 22 as a charging device, a developing roller 24 as a developer carrier, a cleaning roller 25 as a cleaning member, and the like. A surface of the photosensitive drum 21 is uniformly charged by the charging roller 22. The charged surface of the photosensitive drum 21 is exposed by the LED head 23, so that an electrostatic latent image as a latent image is formed. The electrostatic latent image is developed by the developing roller 24, so that toner supplied from the toner container 17i adheres to the surface of the photosensitive drum 21. Thereby, toner images as developer images of the respective colors are formed on the surfaces of the respective photosensitive drums 21.

The transfer unit u1 includes a drive roller r1 as a first roller, a driven roller r2 as a second roller, a transfer belt 26 as a belt movably supported and stretched by the drive roller r1 and driven roller r2, and transfer rollers 28i (i=1, 2, . . . , 4) as transfer members rotatably disposed to face the respective photosensitive drums 21 with the transfer belt 26 therebetween.

While a sheet P is fed to the image forming portion Q1 and conveyed through transfer portions between the photosensitive drums 21 of the respective image forming units 16i and the transfer rollers 28i, the toner images of the respective colors are sequentially transferred onto the sheet P in a superimposed manner by the transfer rollers 28i, so that a color toner image is formed. Toner remaining on the photosensitive drums 21 after the transfer of the toner images of the respective colors onto the sheet P is scraped off and removed from the photosensitive drums 21 by the cleaning rollers 25.

3

For convenience of illustration, in FIG. 2, for each of the image forming units **16i**, toner containers **17i**, LED heads **23i**, and transfer rollers **28i**, only one of them is illustrated.

A fixing unit **31** as a fixing device is disposed downstream of the image forming portion **Q1** in the sheet conveying path **Rt1**. The fixing unit **31** includes a heating roller **32** as a first fixing member and a pressure roller **33** as a second fixing member, and a heater (not illustrated) as a heat source is disposed in the heating roller **32**.

In the fixing unit **31**, while the sheet **P** is conveyed through a fixing portion between the heating roller **32** and the pressure roller **33**, the toner image on the sheet **P** is heated and fused by the heating roller **32**, pressed by the pressure roller **33**, and fixed to the sheet **P**.

The sheet **P** to which the toner image has been fixed is conveyed by a pair of conveying rollers **m2** as a second conveying member, discharged by a pair of discharging rollers **m3** as a third conveying member to the outside of the apparatus main body **Bd**, and placed on a stacker **sk2**.

Next, the toner containers **17i** will be described.

FIG. 1 is a transverse sectional view of a toner container **17i** of the embodiment of the present invention. FIG. 3 is a longitudinal sectional view of the toner container **17i** of the embodiment of the present invention. FIG. 4 is a sectional view taken along line X-X of FIG. 3. FIG. 5 is a perspective view of a screw of the embodiment of the present invention. FIG. 6 is a sectional view taken along line Y-Y of FIG. 3. FIG. 1 is a sectional view taken along line Z-Z of FIG. 3.

In the drawings, the toner container **17i** includes a case **Ct** that is an exterior of the toner container **17i**. The case **Ct** includes a front panel **Pf** on the front side that is the downstream side in a conveying direction of the sheet **P**, a rear panel **Pr** on the rear side that is the upstream side in the conveying direction of the sheet **P**, a top panel **Pt** on the upper side, a bottom panel **Pb** on the lower side, a side panel **Ps1** on the left side as viewed from the upstream side in the conveying direction of the sheet **P**, and a side panel **Ps2** on the right side. Toner is stored in the case **Ct**.

The toner container **17i** is installed on the upper side of the image forming unit **16i** (see FIG. 2) in the printer **10** such that it is inclined by, for example, 10° relative to a horizontal direction with its front end higher than its rear end. This can reduce the projected area on a horizontal plane, thus allowing the printer **10** to be downsized.

A toner outlet **h1** as a developer outlet for discharging toner **T** outside the toner container **17i** is formed in a front end portion of the case **Ct**, or an upper end portion of the bottom panel **Pb**. Also, a shutter **41** as an opening and closing member for opening and closing the toner outlet **h1** is disposed movably in the direction of arrow **A** relative to the case **Ct**. The shutter **41** moves between a closed position where it closes the toner outlet **h1** and an open position where it opens the toner outlet **h1**. A sealing member **43** formed by an elastic body is disposed at the toner outlet **h1** such that it surrounds an outer periphery of the toner outlet **h1**. When the shutter **41** is located at the closed position, the sealing member **43** seals a gap between the bottom panel **Pb** of the case **Ct** and the shutter **41**.

Also, a handle **35** for an operator to grasp the toner container **17i** when detaching it from the image forming unit **16i** and drawing it from the printer **10** is formed on the upper side of an outer surface of the rear panel **Pr** of the case **Ct** to project therefrom.

In the case **Ct**, a toner conveying portion **Ar1** as a developer conveying portion is formed on the side panel **Ps1** side, and a toner storage portion **Ar2** as a developer storage portion is formed on the side panel **Ps2** side, in such a

4

manner that they are each formed adjacent to a guide wall **51** to be described later. A screw **38** as a conveying spiral is rotatably disposed in the toner conveying portion **Ar1**, and an agitator **39** as a stored developer conveying member is rotatably disposed in the toner storage portion **Ar2**, in such a manner that they extend parallel to each other in a longitudinal direction of the case **Ct**. The screw **38** and agitator **39** are rotated by receiving rotation from a driving source (not illustrated) disposed in the printer **10**.

The screw **38** includes a shaft **Sha**, a blade **Wg** formed by a spiral formed around the shaft **Sha** with a predetermined pitch, a connection **Cna** formed at an end of the shaft **Sha** on the front panel **Pf** side and having a D-shaped cross-section, and a supported portion **Spa** formed at an end of the shaft **Sha** on the rear panel **Pr** side and having a circular plate shape. As the screw **38** is rotated in the direction of arrow **C**, it conveys toner **T** from the rear panel **Pr** toward the front panel **Pf**, i.e., toward the toner outlet **h1** in an axial direction (which is the direction of arrow **A**).

Also, a film **Fma** as a push member formed by an elastic body is attached to a front end portion of the screw **38**, specifically a planar portion (or a D-cut portion) of the connection **Cna**. The film **Fma** is rotated with rotation of the screw **38** to convey and push toner **T** around the toner outlet **h1** into the toner outlet **h1**.

A driving force transmitting member **46** is fitted in the connection **Cna** at the front end of the screw **38**, and a support **47** formed in an inner wall of the rear panel **Pr** is engaged with the supported portion **Spa** at the rear end of the screw **38**, so that the screw **38** is rotatably supported.

The driving force transmitting member **46** includes a driving force input portion **46a** having a stepped cylindrical shape and rotatably supported by a bearing hole portion **H1** including two through holes formed in the front panel **Pf**, and a driving force output portion **46b** having a D-shaped cross-section. An engagement hole **h3** formed in the driving force input portion **46a** is engaged with a shaft (not illustrated) of a driving force transmitting system that transmits driving force from the driving source, and the driving force output portion **46b** is engaged (or D-cut engaged) with an engagement hole **h4** formed in the connection **Cna**.

Thereby, driving force transmitted from the driving source is transmitted to the screw **38** through the driving force transmitting member **46**.

A ring-shaped sealing member **48** is disposed between the front end of the screw **38** and an inner surface of the front panel **Pf** to seal a gap between the screw **38** and the front panel **Pf**.

The agitator **39** includes a shaft **Shb**, a connection **Cnb** formed at an end of the shaft **Shb** on the front panel **Pf** side and having a D-shaped cross-section, and a supported portion **Spb** formed at an end of the shaft **Shb** on the rear panel **Pr** side and having a cylindrical shape. The shaft **Shb** is rotatably disposed to extend parallel to the screw **38**.

Also, a film **Fmb** as a push member formed by an elastic body is attached to the shaft **Shb**. The film **Fmb** is rotated with rotation of the agitator **39** (or shaft **Shb**) in the direction of arrow **D** to agitate toner **T** in the toner storage portion **Ar2** and push and convey toner **T** on the bottom panel **Pb** toward the guide wall **51** in the direction of arrow **E**.

A driving force transmitting member (not illustrated) for the agitator similar to the driving force transmitting member **46** is fitted in the connection **Cnb** at the front end of the agitator **39**, and a support **49** formed in the inner wall of the rear panel **Pr** is engaged with the supported portion **Spb** at the rear end of the agitator **39**, so that the agitator **39** is rotatably supported. Driving force from the driving source is

5

transmitted to the agitator **39** through the driving force transmitting member for the agitator.

The screw **38** is rotated in the direction of arrow C, thereby conveying toner T in the direction of arrow A, which is the axial direction. At this time, if the entire outer periphery of the blade Wg of the screw **38** is open outward in radial directions, toner T between blades is released outward in radial directions by centrifugal force, and toner T cannot be stably conveyed.

Thus, in this embodiment, the guide wall **51**, which covers a lower portion of the outer periphery of the blade Wg of the screw **38** is formed along the screw **38** in a portion of the toner conveying portion Ar1 facing the screw **38**. The guide wall **51** includes an arc-shaped surface Sa, and is formed from the rear panel Pr to the front panel Pf to project such that the outer periphery of the blade Wg of the screw **38** is covered by the arc-shaped surface Sa. The guide wall **51** guides toner T in the axial direction of the screw **38**.

If the guide wall **51** is formed entirely between the rear panel Pr and the front panel Pf, when the film Fma is rotated with rotation of the screw **38**, the film Fma cannot reliably push toner T around the toner outlet h1 into the toner outlet h1. Specifically, in this case, since the film Fma discharges toner while rubbing toner against the guide wall **51**, some toner cannot climb over the guide wall **51**, and toner cannot be smoothly discharged.

Thus, in this embodiment, a cutout is formed at a portion of the guide wall **51** corresponding to the film Fma to form a guide portion that guides toner T to the toner outlet h1. For example, a guide portion for guiding toner T to the toner outlet h1 is formed by cutting out a portion of the guide wall **51** corresponding to the film Fma. In an aspect, the guide portion formed in the guide wall **51** is an inclined surface inclined downward toward the toner outlet h1. Specifically, an inclined surface Sb as a guide portion for guiding toner T to the toner outlet h1 is formed by cutting out a portion of the guide wall **51** adjacent to the toner outlet h1 and corresponding to the film Fma. The inclined surface Sb has a rectangular shape. The inclined surface Sb is formed by declining an edge portion of the bottom panel Pb on the side panel Ps2 side of the toner outlet h1 toward the side panel Ps1.

Next, an operation of the toner container **17i** will be described.

When the amount of toner T in the image forming unit **16i** is reduced due to image formation by the printer **10**, driving force is transmitted from the driving source to the connections Cna and Cnb, the screw **38** and agitator **39** are rotated, and the films Fma and Fmb are rotated.

Thereby, toner T in the toner storage portion Ar2 is conveyed by the film Fmb toward the screw **38** in the direction of arrow E, conveyed along the screw **38** toward the toner outlet h1 in the direction of arrow A, and pushed into the toner outlet h1 by the film Fma.

Since the inclined surface Sb, which declines toward the toner outlet h1, is formed in the guide wall **51**, the toner is reliably pushed into the toner outlet h1, smoothly discharged outside the case Ct, and supplies to the image forming unit **16i**.

As described above, in this embodiment, since a portion of the guide wall **51**, which is disposed along the screw **38**, corresponding to the film Fma is cut out so that the inclined surface Sb is formed, it is possible to reliably push toner T into the toner outlet h1 by means of the film Fma without rubbing toner T against the guide wall **51**. Thus, it is possible to smoothly discharge toner T.

6

In the above embodiment, the toner outlet h1 is formed in the front end portion of the case Ct. However, the toner outlet h1 may be formed in another portion of the case Ct. For example, the toner outlet h1 may be formed in a central portion of the case Ct in the axial direction. In this case, the screw **38** and guide wall **51** may be formed on both sides of the toner outlet h1.

The toner container **17i** may be configured such that the case Ct has a first end portion and a second end portion opposite the first end portion in the axial direction, the toner outlet h1 is formed in the first end portion of the case Ct, and the case Ct is disposed to be inclined such that the first end portion is higher than the second end portion.

Although the above embodiment describes the printer **10**, embodiments of the present invention can be applied to image forming apparatuses, such as copiers, facsimile machines, and multi-function peripherals.

Embodiments of the present invention are not limited to the above-described embodiments, and various modifications can be made thereto.

What is claimed is:

1. A developer container comprising:

a case that stores developer and in which a developer outlet for discharging the developer is formed;

a conveying spiral that is rotatably disposed in the case and rotates to convey the developer toward the developer outlet in an axial direction of the conveying spiral;

a guide wall that is disposed along the conveying spiral and guides the developer in the axial direction of the conveying spiral; and

a push member that is attached to the conveying spiral and rotates with the conveying spiral to push the developer into the developer outlet, wherein

a cutout is formed at a portion of the guide wall corresponding to the push member to form a guide portion that guides the developer to the developer outlet,

the case has a first end portion and a second end portion opposite the first end portion in the axial direction,

the developer outlet is formed in the first end portion of the case, and

the case is disposed to be inclined such that the first end portion is higher than the second end portion.

2. The developer container of claim 1, wherein the guide portion formed in the guide wall is an inclined surface inclined downward toward the developer outlet.

3. The developer container of claim 1, wherein a developer storage portion that stores the developer is formed adjacent to the guide wall in the case, and

a stored developer conveying member that conveys the developer toward the guide wall is disposed in the developer storage portion.

4. The developer container of claim 3, wherein the guide portion has an inclined surface inclined downward from a lower surface of the developer storage portion toward the developer outlet.

5. The developer container of claim 3, wherein the stored developer conveying member includes:

a shaft rotatably disposed to extend parallel to the conveying spiral; and

a push member that is attached to the shaft and rotates with the shaft to push the developer toward the guide wall.

6. The developer container of claim 5, wherein in the axial direction, the push member of the stored developer conveying member extends so as to reach a position at which the guide portion is disposed.

7

8

7. An image forming apparatus comprising the developer container of claim 1.

8. The developer container of claim 1, wherein a center of a shaft of the conveying spiral is located above the guide wall.

5

* * * * *