

S. MARSCHIK.
 WAGE REGISTERING APPARATUS FOR MECHANICAL LOOMS AND SIMILAR TEXTILE MACHINES.
 APPLICATION FILED FEB. 11, 1910.

1,002,720.

Patented Sept. 5, 1911.

4 SHEETS—SHEET 1.

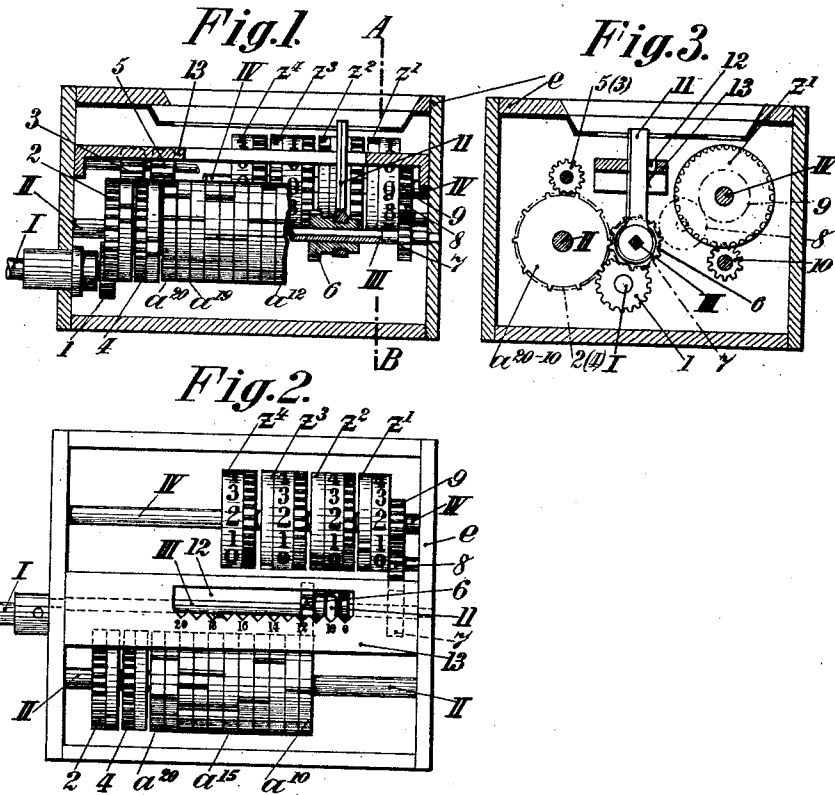

Witnesses:
Burhold F. ...
Gerhard Pagel

Inventor:
Samuel Marschik

S. MARSCHIK.

WAGE REGISTERING APPARATUS FOR MECHANICAL LOOMS AND SIMILAR TEXTILE MACHINES.
APPLICATION FILED FEB. 11, 1910.

1,002,720.

Patented Sept. 5, 1911.

4 SHEETS—SHEET 2.

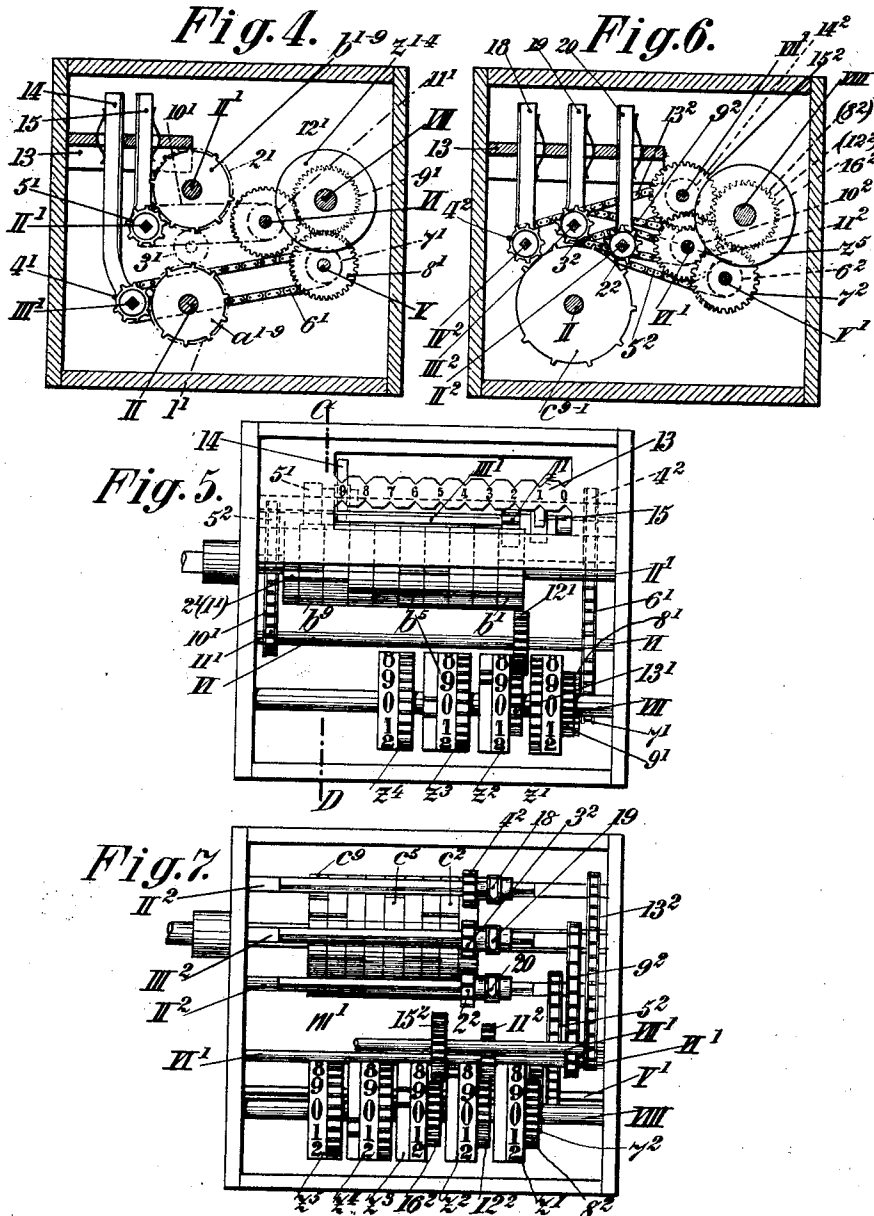

Witnesses:
Balthasar Pankke
Gerhard Pagel

Inventor:
Samuel Marschik

S. MARSCHIK.
 WAGE REGISTERING APPARATUS FOR MECHANICAL LOOMS AND SIMILAR TEXTILE MACHINES.
 APPLICATION FILED FEB. 11, 1910.

1,002,720.

Patented Sept. 5, 1911.

4 SHEETS—SHEET 3.

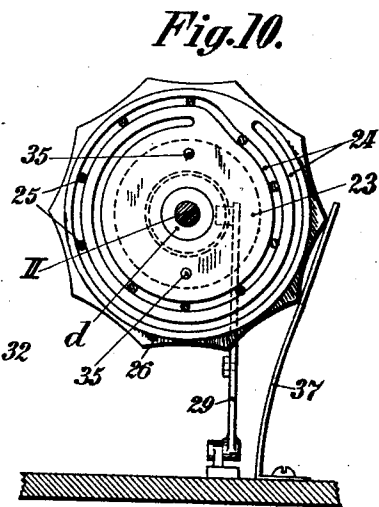
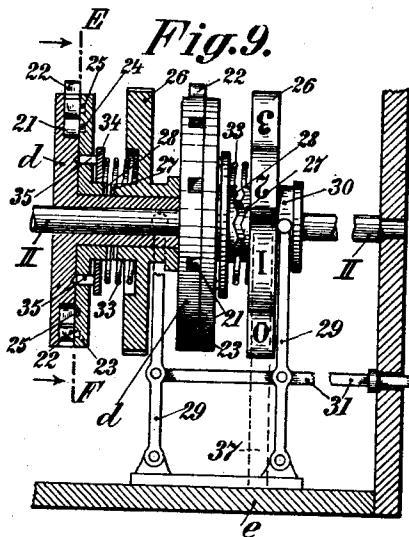
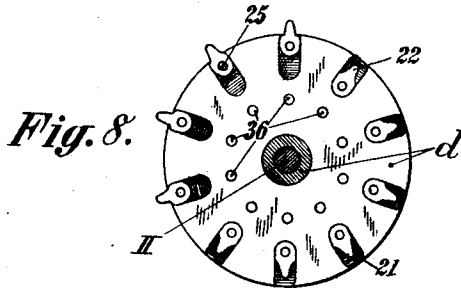

Witnesses:

*Barthold Fankha
 Gerhard Pagel.*

Inventor:

Samuel Marschik

S. MARSCHIK.
 WAGE REGISTERING APPARATUS FOR MECHANICAL LOOMS AND SIMILAR TEXTILE MACHINES.
 APPLICATION FILED FEB. 11, 1910.

1,002,720.

Patented Sept. 5, 1911.

4 SHEETS—SHEET 4.

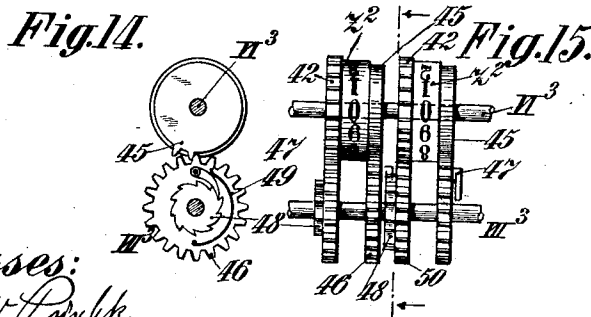
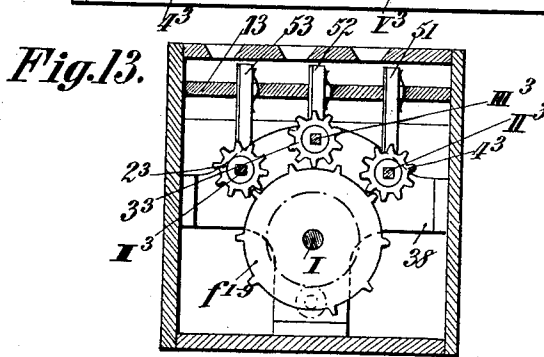
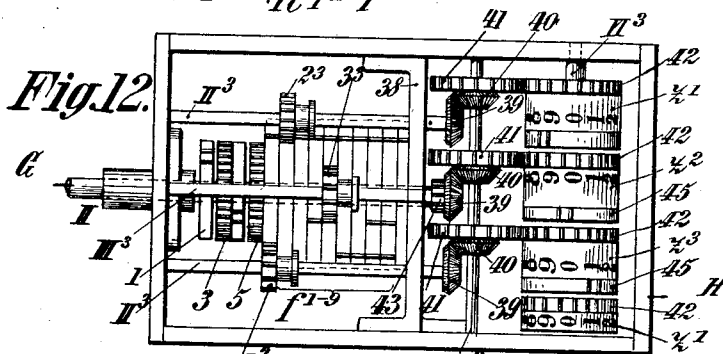
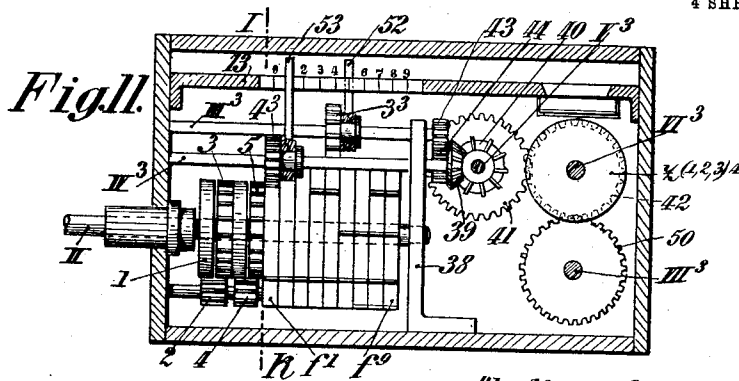

Witnesses:
Burkhardt Pankke
Gerhard Pajel

Inventor:
Samuel Marschik

UNITED STATES PATENT OFFICE.

SAMUEL MARSCHIK, OF BRÜNN, AUSTRIA-HUNGARY.

WAGE-REGISTERING APPARATUS FOR MECHANICAL LOOMS AND SIMILAR TEXTILE-MACHINES.

1,002,720.

Specification of Letters Patent.

Patented Sept. 5, 1911.

Application filed February 11, 1910. Serial No. 543,387.

To all whom it may concern:

Be it known that I, SAMUEL MARSCHIK, a subject of the Austro-Hungarian Emperor, and resident of 37 Schmerlingstrasse, Brunn, Austria-Hungary, have invented certain new and useful Improvements in Wage-Registering Apparatus for Mechanical Looms and Similar Textile-Machines, of which the following is a specification.

My invention relates to improvements in an apparatus for registering wages for mechanical looms and similar textile machines, and more precisely to an apparatus for registering wages of the kind described in my specifications of January 27, 1908 and September 30, 1908.

The object of the invention is to make it easy to adjust such a registering-apparatus for any required rate of wages, without having to take the apparatus to pieces for re-adjusting it.

The invention consists in the main in driving by the loom a number of toothed disks with different numbers of teeth in a manner that the same make one revolution per work-unit (for instance 1000 wefts or 300 yards) and in bringing into engagement with one or the other of these toothed disks, according to the rate of the wages, an adjustable transmission-wheel, whose rotation can be transmitted to and made to engage with the corresponding place of a counter.

My invention is illustrated in the accompanying drawings in several sample forms of construction.

Figures 1-3 show one form of construction. Fig. 1 is a front-view and partly a vertical section of the apparatus. For the sake of distinctness several parts have been omitted. Fig. 2 is a front-view and partly a horizontal section of the same. Fig. 3 is a vertical section on the line A—B of Fig. 1. Fig. 4 shows a second form of construction of the apparatus in a vertical section on the line C—D of Fig. 5. Fig. 5 is a plan-view of this apparatus with the cover of the casing removed. Fig. 6 shows a third form of construction of the apparatus in a vertical section and Fig. 7 shows the same in a plan view with the cover of the casing removed. Figs. 8-10 show single parts of a fourth form of construction. Fig. 8 is a section on the line E—F of Fig. 9. Fig. 9 is a side-view and a vertical section and Fig. 10 likewise a section on the line E—F,

but seen in the direction of the arrow. Figs. 11-15 show a further form of construction. Fig. 11 is a vertical section on the line G—H of Fig. 12. Fig. 12 is a plan view with the cover of the casing removed. Fig. 13 is a vertical section on the line I—K of Fig. 11. Figs. 14 and 15 show a part of a tens-transmitting device for the counter, in two different views.

In the form of construction shown in Figs. 1-3 there is actuated by the spindle I driven by the loom a set of gearing 1, 2, 3, 4 and 5, whose wheels 2, 4 are loosely turnable on the spindle II. The toothed wheel 5 of this set of gearing meshes with the toothed disk a^{20} of the eleven toothed disks $a^{10}, a^{11} \dots a^{20}$ connected with each other and drives the same in a manner that they make one revolution per work-unit (1000 wefts or 300 yards). These toothed disks have different numbers of teeth, namely from a^{20} with 20 teeth to a^{10} with 10 teeth, so that this apparatus can be used for rates of wages varying between 10 and 20 monetary-units.

On a square shaft III is shiftably arranged a toothed transmission-wheel 6, which, in accordance with the number of monetary-units contained in the respective rate of wages, can be moved into engagement with one of the different toothed disks $a^{10}-a^{20}$. As shown in the drawings, this transmission-wheel 6 meshes with the disk a^{10} , which corresponds with a rate of wages of 10 monetary-units.

The rotation of the shaft III is transmitted by three toothed wheels 7, 8 and 9 of the same size to the units figure-wheel z^1 of a counter arranged on the shaft IV. The rotation of the units figure wheel z^1 is transmitted to the other figure-wheels z^2, z^3, z^4 of the counter by a gear 10 constructed in well known manner for the tens-transmission. (Fig. 3.) For varying the rate of wages it is with this arrangement only necessary to shift the toothed transmission-wheel 6 on the shaft III. This can be effected by means of a handle 11 guided in the slot 12 of a rail 13 and projecting out of the casing e inclosing the apparatus. By rests or notches arranged in this rail 13 and marked, as shown in Fig. 2, with corresponding figures, the handle 11 standing under the action of a spring can be secured in any desired position. If the handle 11 is

fixed in the rest at the farthest end on the right and marked with o , the toothed wheel 6 is not in engagement with any of the operating-disks a^1 — a^9 . In this position the counter-wheels can be turned to zero.

In the apparatus according to Figs. 4 and 5 there is again marked with II the spindle which is driven in a manner that it makes one revolution per work-unit (1000 wefts or 300 yards). To this spindle are fixed the toothed disks $a^1, a^2, a^3 \dots a^9$ which have different numbers of teeth, namely from 1 to 9 teeth. By a toothed wheel 1^1 fixed to the spindle II there is driven, by means of the toothed wheels 3^1 and 2^1 , a second spindle II^1 at the same speed and in the same direction. On the spindle II^1 are likewise fastened 9 toothed disks $b^1, b^2 \dots b^9$, which likewise possess different numbers of teeth, namely from 1—9 teeth. In front of each of these two sets of toothed disks there is shiftably arranged on a square spindle III^1 and IV^1 a toothed transmission wheel 4^1 and 5^1 respectively, of which the wheel 4^1 can be moved into engagement with the toothed disks a^1 — a^9 and the wheel 5^1 with the toothed disks b^1 — b^9 . The rotation of the spindle III^1 is transmitted by a toothed wheel 4^2 arranged on the same by means of a chain 6^1 to a chain wheel 7^1 fastened on a shaft V. On the latter is further fastened a toothed wheel 8^1 which meshes with a toothed wheel 9^1 of the same size connected with the units figure-wheel z^1 of the counter $z^1, z^2 \dots$, arranged on the shaft VII. The rotation of the wheel 5^1 is transmitted by a toothed wheel 5^2 on the shaft IV^1 by means of a chain 10^1 to a chain-wheel 11^1 fastened on the shaft VI. On the latter is fastened a toothed wheel 12^1 which meshes with a toothed wheel 13^1 of the same size connected with the tens-figure-disk z^2 of the counter. From the foregoing therefore results that by means of the transmission wheel 4^1 the units of the rate of wages can be inserted, and by means of the transmission wheel 5^1 the tens. The construction according to Figs. 4 and 5 is therefore suited for rates of wages of from 1—99 monetary-units. The transmission-wheels 4^1 and 5^1 are adjusted by means of the handles 14, 15 which can likewise be fixed in the rests or notches of a rail 13 provided with corresponding marks.

In the construction according to Figs. 6 and 7 II marks again the spindle which is driven from the loom or the like in a manner that it makes one revolution per work-unit. To this spindle are fixed nine toothed disks $c^1, c^2 \dots c^9$. These toothed disks possess different numbers of teeth, namely from 1—9 teeth and have a circumference of thirty tooth-divisions or indentations, while the teeth are at intervals from each other

of three of these divisions. In consequence of this it is possible to arrange the transmission-wheels $2^2, 3^2, 4^2$ on the square shafts II^2, III^2, IV^2 in a manner that the engagement of the toothed disks with these transmission wheels never takes place simultaneously but in succession. A similar arrangement has also been made in the construction according to Figs. 4 and 5. The rotation of the transmission-wheel 2^2 is transmitted by chain 5^2 to a chain wheel 6^2 arranged on a shaft V^1 . To the latter is fixed a toothed wheel 7^2 , which meshes with the toothed wheel 8^2 of the units figure-wheel z^1 of the counter on the shaft VIII. From the transmission-wheel 3^2 the movement is transmitted by the chain 9^2 to a chain-wheel 10^2 fixed to the shaft VI^1 . To this shaft is fixed a toothed wheel 11^2 which meshes with the toothed wheel 12^2 of the same size of the tens-figure-wheel z^2 of the counter. From the transmission-wheel 4^2 the movement is transmitted in the same manner by the chain 13^2 to a chain wheel 14^2 on the shaft VII¹. From the latter the movement is transmitted by a toothed wheel 15^2 to the toothed wheel 16^2 of the same size of the hundreds figure wheel z^3 of the counter. The transmission-wheel 2^2 therefore indicates the units, the transmission-wheel 3^2 the tens and the transmission-wheel 4^2 the hundreds of the wages. The above described construction is therefore suited for rates of wages of from 1 to 999 monetary-units. The adjustment of the three transmission-wheels is effected by means of the handles 18, 19 and 20, which can be secured in rests of a rail 13 provided with corresponding marks.

The construction according to Figs. 8–10 differs from the above described in that respect that instead of the toothed disks with different numbers of teeth there are used toothed disks provided with the same number of adjustable teeth. Each one of these toothed disks d shows ten radial slots (Fig. 8) in which the teeth 22 can be shifted. By the side of each of the toothed disks d fastened on the shaft II is turnably arranged a disk 23, in which there is provided a spiral groove 24. Into this groove engage the pins 25 fastened on said teeth 22. If with this arrangement the disk 23 is turned the pins 25 get from the inner part of the groove 24 into the outer or vice versa, in consequence of which the teeth 22 are moved forward beyond the circumference of the disk d or backward. The turning of the disk 23 is effected by means of a figure-wheel 26, which can be shifted on the shaft II, whereby the coupling-teeth 27 arranged on the figure-wheel can be moved into engagement with the coupling teeth 28 on the disk 23. The figure-wheels 26 are shifted by means of the levers 29 which engage with a pin into a groove 30 in the hub of

the figure-wheels 26. The levers 29 are pivoted in the casing *e* in which the whole mechanism is inclosed, and they are connected with each other by a rod 31, which projects through the wall of the casing and is provided with a knob or handle 32. By shifting the rod 31 the coupling-parts 27, 28 can be moved into engagement with each other, and hereupon the figure-wheels can be adjusted in accordance with the rate of wages. The corresponding number of teeth are hereby moved forward over the circumference of the several toothed disks *d*. After the adjustment the knob 32 is released again and each one of the figure-wheels 26 is shifted into its normal position by a spring 33, which rests on the one side against the figure-wheel 26 and on the other against a plate 34. On the plate 34, which is shiftable on the hub of the disk 23, are fastened two pins 35 which engage after each 1/10 revolution of the disk 23 into corresponding recesses 36 provided in the toothed disk *d* and couple the toothed disk *d* with the disk 23. In consequence of the automatic throwing out of engagement of the figure-wheels 26 by means of the springs 33, the figure-wheels remain in their position during the operation of the registering apparatus and are besides this secured in their position by flat springs 37, so that they indicate the rate of wages at any time.

For each place of the rate of wages the arrangement is, of course, the same. In Fig. 9 the arrangement is illustrated for a rate of wages having two places. Corresponding to the number of teeth adjusted in each toothed disk *d* the respective figure-wheel of the counter is driven.

In the case of the construction according to Figs. 11-15 there are again arranged on the shaft II nine toothed disks f^1, f^2, \dots, f^9 with different numbers of teeth, namely 1-9 teeth. These toothed disks are also driven by the loom in a manner that they make one revolution per work-unit.

On the shafts II³, III³, IV³, which are journaled on the one side in the wall of the casing *e* and, on the other, in a partition-wall 38 the transmission-wheels 2³, 3³, 4³ can be shifted and be moved into engagement with one of the toothed disks f^1, f^2, \dots, f^9 , according to the multiples of monetary units in the different places of the rate of wages.

The rotation of the shaft II³ is transmitted by means of a bevel-wheel 39 to a second bevel wheel 40 loosely arranged on the shaft V³ and from here by means of the toothed wheel 41 to the toothed wheel 42 of the units figure-wheel z^1 of the counter arranged on the shaft VI³. The rotation of the shaft III³ is transmitted in the same manner to the toothed wheel 42 of the tens-figure-wheel z^2 of the counter, but with the inter-

calation of the toothed wheels 43, 44. The rotation of the shaft IV³ is likewise transmitted by means of bevel-wheels 39, 40 and the toothed wheel 41 to the toothed wheel 42 of the hundreds figure-wheel z^3 of the counter.

The same as with the counters of the above described construction, there has also here been provided a tens-transmission device illustrated in Figs. 14 and 15. The mode of working of this device is as follows. If one of the figure-wheels, for instance z^2 , has made a full revolution, a two-teeth wheel 45 connected with the same, comes into engagement with a twenty-teeth wheel 46 turnable on a shaft VII³ and turns it to the extent of 1/10 of its circumference. A pawl 47 fastened on this toothed wheel 46 engages with a ratchet-wheel 48 and stands under the action of a spring 49. The ratchet wheel 48 is connected with a toothed wheel 50 likewise loosely arranged on the shaft VII³, which meshes with the toothed wheel 42 fastened to the hundreds figure-wheel z^3 . When the toothed wheel 46 is rotated, the ratchet wheel 48 and the toothed wheel 50 are likewise rotated by the pawl and hereby the figure-wheel z^3 is moved forward for one figure. If however the figure-wheel z^3 is moved by the toothed disks f^1, f^2, \dots, f^9 , the teeth of the ratchet wheel 48 can freely move under the pawl 47. The adjustment of the transmission-wheels 2³, 3³, 4³ is in this construction also effected by means of the handles 51, 52, 53, which can be secured in the rests or notches of a plate 13 provided with corresponding marks. Of course also with this arrangement the transmission-wheels 2³, 3³, 4³ are distributed over the circumference of the toothed disks in a manner that the latter come never simultaneously but in succession into engagement with the transmission-wheels.

What I claim as my invention and desire to secure by Letters Patent is:—

1. In an apparatus of the kind described in combination, a number of toothed disks having different numbers of teeth and adapted to be driven from a suitable part of the loom so that they make one revolution per work-unit, a counter of any desired construction, transmission wheels adapted to be brought into engagement with one of the said toothed disks, the teeth on said toothed disks being arranged at intervals of three tooth-divisions, and the said transmission wheels being set on the circumference of said toothed disks at intervals of one tooth division more than three tooth-divisions, and means for transmitting the rotation of said transmission-wheels to said counter, substantially as set forth.

2. In an apparatus of the kind described in combination, a set of toothed disks having from 1-9 teeth and adapted to be

driven from a suitable part of the loom so
 that they make one revolution per work-
 unit, a counter of any desired construction,
 a number of transmission wheels correspond-
 5 ing to the number of places in the rate of
 wages and adapted to be brought into en-
 gagement with said toothed disks, each of
 said transmission wheels having ten teeth, a
 10 number of spindles, each of said transmission-
 wheels being shiftably arranged on one of
 said spindles, the teeth on said toothed disks
 being arranged at intervals of three tooth-
 divisions, and the said transmission wheels
 15 being set on the circumference of said
 toothed disks at intervals of one tooth di-

vision more than three tooth-divisions, and
 means for transmitting the rotation of each
 of said transmission-wheels to the corre-
 sponding figure wheels of said counter, and
 means for shifting said transmission wheels 20
 substantially as set forth.

In testimony whereof I have hereunto
 signed my name this 8th day of January,
 1910, in the presence of two subscribing
 witnesses.

SAMUEL MARSCHIK.

Witnesses:

AUGUST FUGGER,
 CHAS. G. LASLEY.

Copies of this patent may be obtained for five cents each, by addressing the "Commissioner of Patents,
 Washington, D. C."