



(86) Date de dépôt PCT/PCT Filing Date: 2009/11/30
 (87) Date publication PCT/PCT Publication Date: 2010/06/17
 (85) Entrée phase nationale/National Entry: 2011/05/19
 (86) N° demande PCT/PCT Application No.: IB 2009/055424
 (87) N° publication PCT/PCT Publication No.: 2010/067253
 (30) Priorité/Priority: 2008/12/10 (US12/331,621)

(51) Cl.Int./Int.Cl. *E04H 5/10* (2006.01),
F25J 3/04 (2006.01)
 (71) Demandeur/Applicant:
L'AIR LIQUIDE SOCIETE ANONYME POUR L'ETUDE
ET L'EXPLOITATION DES PROCEDES GEORGES
CLAUDE, FR
 (72) Inventeurs/Inventors:
PELTIER, STEPHANE, US;
COTE, DENIS, US;
HARDY, YVES, CA;
POULIN, GILLES, CA
 (74) Agent: LEDGLEY LAW

(54) Titre : PROCÉDE HYBRIDE D'ERECTION D'UNE COLONNE DE DISTILLATION A PARTIR DE COMPOSANTS
PREFABRIQUES ET ERIGES SUR SITE
 (54) Title: HYBRID METHOD OF ERECTING A COLD BOX USING PREFABRICATED AND FIELD ERECTED
COMPONENTS

Fig. 5

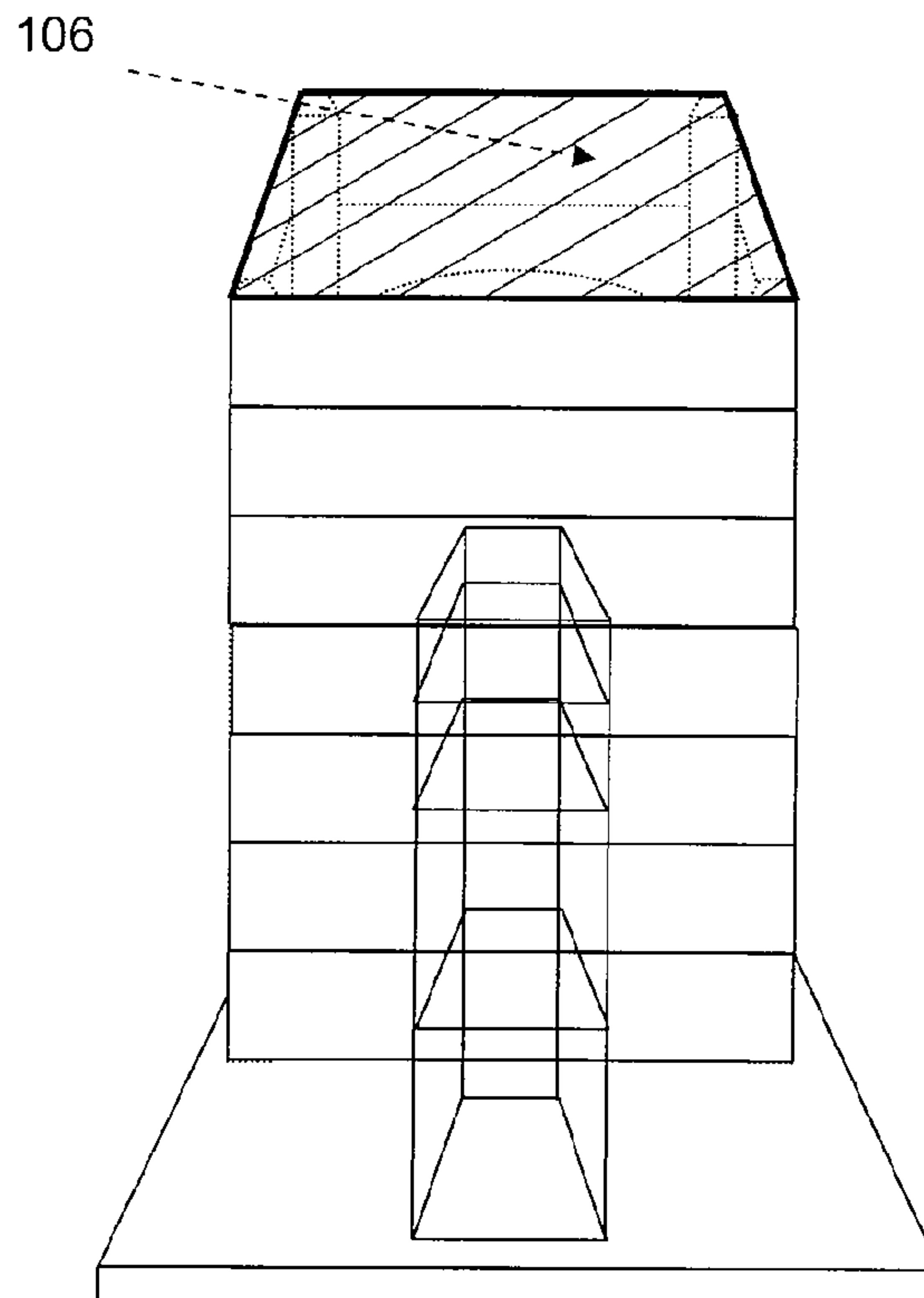

(57) **Abrégé/Abstract:**

A method of erecting a cold box that includes the steps of anchoring at least one column (102) to a foundation (101) in a substantially vertical orientation; anchoring a pipe rack module (103) to the foundation in a substantially vertical orientation, wherein

(57) **Abrégé(suite)/Abstract(continued):**

the pipe rack module is in close proximity to the at least one column; attaching interconnecting piping between the pipe rack module and the at least one column; anchoring at least four corner beams (104) to the edge of the foundation in a substantially vertical orientation; attaching prefabricated panels (105) with bracing to the corner beams, to form an enclosure around the column and piping; and attaching a roof (106) to the enclosure is provided.

(12) INTERNATIONAL APPLICATION PUBLISHED UNDER THE PATENT COOPERATION TREATY (PCT)

(19) World Intellectual Property Organization
International Bureau(43) International Publication Date
17 June 2010 (17.06.2010)(10) International Publication Number
WO 2010/067253 A1(51) International Patent Classification:
E04H 5/10 (2006.01) *F25J 3/04* (2006.01)77479 (US). **POULIN, Gilles** [CA/CA]; 5331 Taillon,
Montreal, québec H1K 4T7 (CA).(21) International Application Number:
PCT/IB2009/055424(81) Designated States (unless otherwise indicated, for every
kind of national protection available): AE, AG, AL, AM,
AO, AT, AU, AZ, BA, BB, BG, BH, BR, BW, BY, BZ,
CA, CH, CL, CN, CO, CR, CU, CZ, DE, DK, DM, DO,
DZ, EC, EE, EG, ES, FI, GB, GD, GE, GH, GM, GT,
HN, HR, HU, ID, IL, IN, IS, JP, KE, KG, KM, KN, KP,
KR, KZ, LA, LC, LK, LR, LS, LT, LU, LY, MA, MD,
ME, MG, MK, MN, MW, MX, MY, MZ, NA, NG, NI,
NO, NZ, OM, PE, PG, PH, PL, PT, RO, RS, RU, SC, SD,
SE, SG, SK, SL, SM, ST, SV, SY, TJ, TM, TN, TR, TT,
TZ, UA, UG, US, UZ, VC, VN, ZA, ZM, ZW.(22) International Filing Date:
30 November 2009 (30.11.2009)

(25) Filing Language: English

(26) Publication Language: English

(30) Priority Data:
12/331,621 10 December 2008 (10.12.2008) US(71) Applicant (for all designated States except US): **L'AIR
LIQUIDE SOCIETE ANONYME POUR L'ETUDE
ET L'EXPLOITATION DES PROCEDES GEORGES
CLAUDE** [FR/FR]; 75 quai d'Orsay, F-75007 Paris (FR).(84) Designated States (unless otherwise indicated, for every
kind of regional protection available): ARIPO (BW, GH,
GM, KE, LS, MW, MZ, NA, SD, SL, SZ, TZ, UG, ZM,
ZW), Eurasian (AM, AZ, BY, KG, KZ, MD, RU, TJ,
TM), European (AT, BE, BG, CH, CY, CZ, DE, DK, EE,
ES, FI, FR, GB, GR, HR, HU, IE, IS, IT, LT, LU, LV,
MC, MK, MT, NL, NO, PL, PT, RO, SE, SI, SK, SM,
TR), OAPI (BF, BJ, CF, CG, CI, CM, GA, GN, GQ, GW,
ML, MR, NE, SN, TD, TG).(72) Inventors; and
(75) Inventors/Applicants (for US only): **PELTIER,
Stephane** [US/US]; 703 Presley Way, Sugar Land, Texas
77479 (US). **HARDY, Yves** [CA/CA]; 4536 Des Fleurs,
Lachenaie, québec J6V 1G4 (CA). **COTE, Denis**
[CA/US]; 1422 Grand Haven Lane, Sugar Land, Texas

[Continued on next page]

(54) Title: HYBRID METHOD OF ERECTING A COLD BOX USING PREFABRICATED AND FIELD ERECTED COMPO-
NENTS

Fig. 5

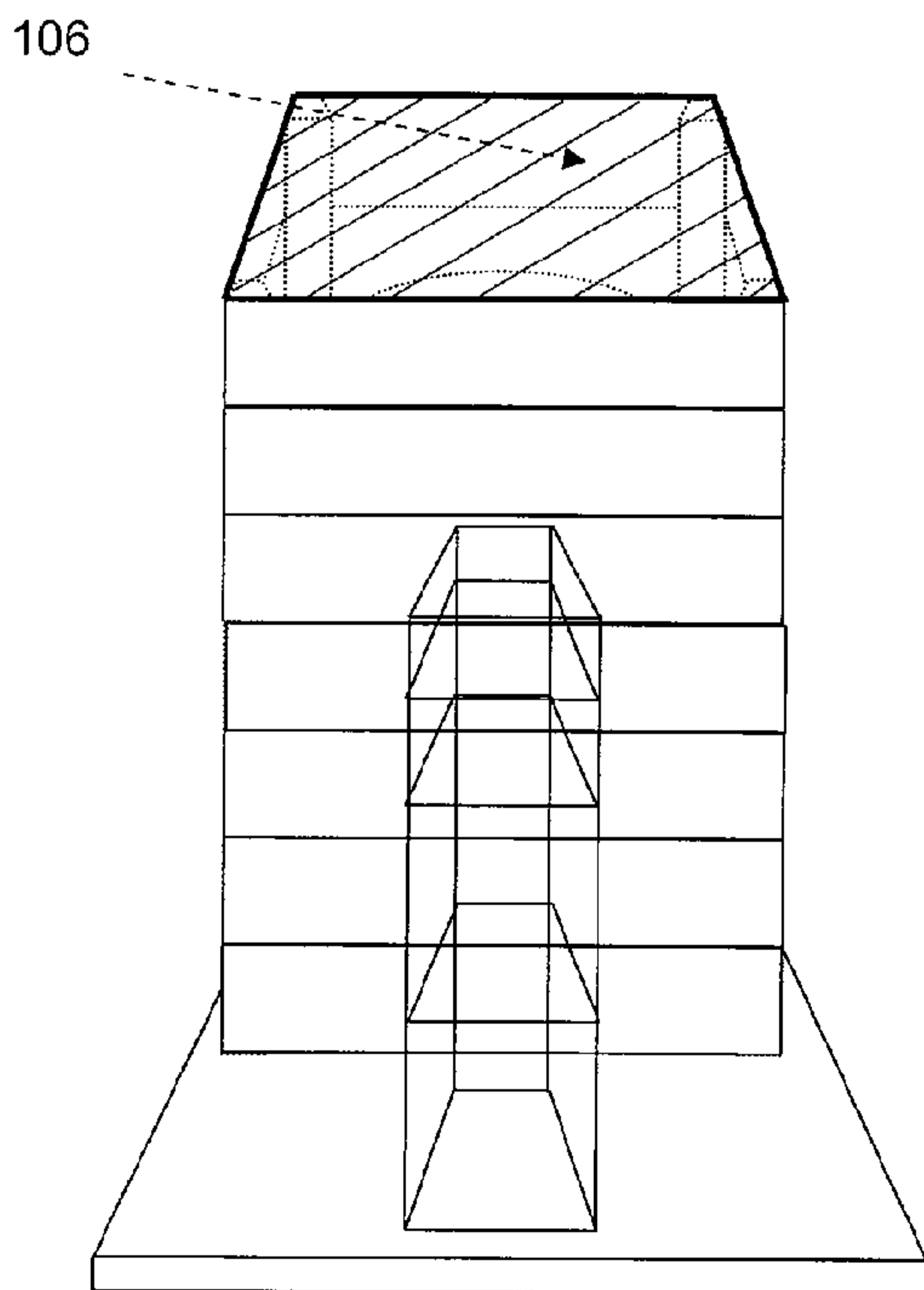

(57) Abstract: A method of erecting a cold box that includes the steps of anchoring at least one column (102) to a foundation (101) in a substantially vertical orientation; anchoring a pipe rack module (103) to the foundation in a substantially vertical orientation, wherein the pipe rack module is in close proximity to the at least one column; attaching interconnecting piping between the pipe rack module and the at least one column; anchoring at least four corner beams (104) to the edge of the foundation in a substantially vertical orientation; attaching prefabricated panels (105) with bracing to the corner beams, to form an enclosure around the column and piping; and attaching a roof (106) to the enclosure.

WO 2010/067253 A1 

Published:

— with international search report (Art. 21(3))

— before the expiration of the time limit for amending the claims and to be republished in the event of receipt of amendments (Rule 48.2(h))

HYBRID METHOD OF ERECTING A COLD BOX USING PREFABRICATED AND FIELD ERECTED COMPONENTS

5

Field of the Invention

This invention relates to a hybrid erection method for fabricating a cold boxy, involving using components that are prefabricated in a shop, and components that are field erected.

10

Background

Conventionally, cryogenic units for the separation of gases comprise at least one distillation column which is disposed within an insulating structure called a cold box. The cold box typically has a substantially parallelepipedal shape so as to provide a predetermined thickness of insulation around the column. It is typical for the cryogenic distillation columns and all of the associated equipment (heat exchangers, cryogenic pumps, cryogenic valves, connecting pipes, etc.) operating at low temperature to be arranged within the cold box and then for the cold box to be filled with an insulator in loose bulk form, such as expanded perlite or compacted mineral wool. This insulator thermally protects each component from the external temperature and from that of other components which may be at different temperatures and heat leak that affects plant performance. This type of material derives its insulating properties from both low thermal conductivity ($<0.05 \text{ W/m}^\circ\text{C}$) and a high head loss which is favourable in terms of the convection phenomenon.

25

30

Typically, in an effort to limit construction costs, and to maximize quality, the column is preassembled with tubing elements to as great of an extent as possible in the controlled environment of the shop. This preassembly

usually consists of a framework corresponding to that of the future cold box, and of a cross section integrating the future insulation thicknesses all about the column. This is often completed prior to transporting and installing the assembly at the worksite. This is typically referred to as a
5 "cold box package". Apart from their weight and their dimensions, sharply driving up the cost of transportation, such completely preassembled assemblies are confronted with serious transportation problems (e.g., difficulties clearing bridges, difficulties transporting the assemblies around corners . . .) largely because of their great size. Also, equipment needed
10 for lifting these packages is less available or extremely expensive. This is currently becoming a greater problem as the dimensions of the column are becoming greater, as dictated by the current need for massive production of gas.

15 An alternative would be to assemble and erect the column, cold box and the ancillary components entirely in the field. This will reduce the transportation issues, and possible reduce issues with misalignment and interconnection of fittings. However, utilizing this route allows the construction process to become vulnerable to variations in the weather,
20 material delivery delays, issues involving labor shortages, and possible quality control problems.

Therefore, there exists a need in the industry for a solution that will allow the above problems to be circumvented.

25

Summary

The present invention is a method of erecting a plant that includes the steps of anchoring at least one column to a foundation in a substantially
30 vertical orientation; anchoring a pipe rack module to the foundation in a

substantially vertical orientation, wherein the pipe rack module is in close proximity to the at least one column; attaching interconnecting piping between the pipe rack module and the at least one column; anchoring at least four corner beams to the edge of the foundation in a substantially vertical orientation; attaching prefabricated panels with bracing to the corner beams, to form an enclosure around the column and piping; and attaching a roof to the enclose.

In one embodiment of the present invention, the pipe rack module is prefabricated. In another embodiment of the present invention, the pipe rack module comprises one or more elements selected from the group consisting of control valves, manual valves, sample connections, piping, pre-cut panels with valve actuators, instrumentation, vapo flash, lighting, ladders and platforms, pre-wired junction box, instrument/electrical cable trays, piping support, duct to exchanger box, and the pump module.

In one alternative embodiment of the present invention, the at least one column comprises one or more elements selected from the group consisting of waste line, separator pots, large safety valve lines. In still another embodiment of the present invention, there is also a second pipe rack module. In yet another embodiment of the present invention, the second pipe rack module comprises one or more elements selected from the group consisting of waste line, separator pots, and large safety valve lines.

In still another embodiment of the present invention, the prefabricated panels are attached to the corner beams by bolting. In yet another embodiment of the present invention, the prefabricated panels are connected vertically or horizontally. In a still further embodiment of the

present invention, the prefabricated panels are attached to the edge of the foundation or to adjacent prefabricated panels with bolts.

Brief Description of Drawings

5 The invention may be understood by reference to the following description taken in conjunction with the accompanying drawings, and in which:

 Figure 1 is a schematic representation of the step of anchoring at
10 least one column to a foundation in accordance with one embodiment of the present invention.

 Figure 2 is a schematic representation of the step of anchoring a pipe rack module to a foundation in accordance with one embodiment of the present invention.

15 Figure 3 is a schematic representation of the step of anchoring at least four corner beams to a foundation in accordance with one embodiment of the present invention.

 Figure 4 is a schematic representation of the step of attaching prefabricated panels to the corner beams in accordance with one
20 embodiment of the present invention.

 Figure 5 is a schematic representation of the step of attaching a roof to the enclosure in accordance with one embodiment of the present invention.

Description of Preferred Embodiments

25 The present invention has for its object to provide a method that permits maintaining the quality criteria of preassembly in the factory of elements requiring high quality control, greatly limiting the problems and the costs of transport to the utilization site and facilitating its installation on site in
30 various types of cold boxes.

To accomplish this, according to one characteristic of the invention, the construction method comprises the steps of forming a preassembled pipe rack module. This pipe rack module may be preassembled in the shop where quality control may be more precisely monitored. The construction
5 method may also include the preassembly of the column and its ancillary components in the shop, provided that the column itself is not too large to be transported to the construction site. These preassembled components are relocated to the construction site, where they are interconnected. A field erected cold box is then constructed to surround and insulate the
10 cryogenic components, thereby resulting in a hybrid, field erected and prefabricated assembly.

The method of the present invention allows for the erecting a cold box in the field utilizing prefabricated and field erected components. The first step
15 of the method comprises anchoring at least one column to a foundation in a substantially vertical orientation

The second step comprises anchoring a pipe rack module to said foundation in a substantially vertical orientation, wherein said pipe rack
20 module is in close proximity to said at least one column. In the third step interconnecting piping is attached between said pipe rack module and said at least one column... The next step involves anchoring at least four corner beams to the edge of said foundation in a substantially vertical orientation. Next, the prefabricated panels are attached with bracing to said corner
25 beams, to form an enclosure around said column and piping. Finally a roof is attached to the enclosure.

Turning to Figure 1, a foundation **101** is created. Foundation **101** may be made of materials, and with techniques, well known in the art. Upon the
30 foundation **101**, a pre-assembled column **102** is delivered and installed in a

substantially vertical orientation. The preassembled column **102** may be installed by techniques that are well known in the art. In this context, substantially vertical is understood to mean that preassembled column **102** is oriented in such a manner that the descending liquid-phase fluid within
5 the column interacts with the rising vapour-phase fluid in the manner intended by the column designers. In one embodiment, substantially vertical is within 5 degrees of normal with respect to horizontal. In another embodiment, substantially vertical is within 2 degrees of normal with respect to horizontal. The column **102** may also include one or more
10 additional components selected from a waste line, separator pots or large safety valves. The column **102** may comprise one distillation column or multiple distillation columns.

Turning to Figure 2, also on foundation **101**, a pre-assembled pipe rack
15 module **103** is delivered and installed in a substantially vertical orientation. Pre-assembled pipe rack module **103** may be fabricated in a facility in such a manner that conditions such as inclement weather, limited visibility, labor shortages, etc do not affect the quality, schedule, or delivery of this component. The pipe rack module **103** is located, in close proximity to the
20 column **102**. In this context, close proximity is understood to mean as close as is practical, thereby limiting the length of the various interconnections, and minimizing the amount of field welding and assembly. In one embodiment, close proximity is less than 20 feet. In another embodiment, close proximity is less than 15 feet. The pipe rack module **103**
25 may also include one or more additional components selected from control valves, manual valves, sample connections, interconnecting piping, pre-cut panels with valve actuators, instrumentation, vapo flash, lighting, ladders and platforms, pre-wired junction box, instrument/electrical cable trays, piping support, and duct to exchanger box. Once the pipe rack module

103 is in place, the multiple interconnections with column **102** are fabricated in the field.

Turning to Figure 3, also on the foundation **101**, beams **104** are installed in a substantially vertical orientation. Typically there will be four such beams **104** installed at the corners. Other possible layouts include any building design that accommodates the size and shape required of the pipe rack module **103** and column **102**. In one embodiment, there are from four to eight beams **104**. As indicated in Figure 4, prefabricated panels **105** with bracing are then attached to corner beams **104** to form an enclosure around column **102**. These prefabricated panels **105** may be sized to accommodate local, commercially available plate sizes. These prefabricated panels **105** may be sized to allow for stacking on flat bed trucks for ease of transportation. These prefabricated panels **105** may be attached to one another, and corner beams **104**, by bolts, using gaskets or silicone for sealing. In other embodiments, any attaching means known in the art may be used. These prefabricated panels **104** may be custom made to accommodate manholes, required piping cut-outs, duct connections or Perlite dump connections. As indicated in Figure 5, a roof segment **106** is then added to fully enclose the column **102**. At this time, an insulating material such as perlite may be added to the volume between the enclosure of the panels **105**, roof segment **106** and column **102**.

One skilled in the art would recognize that it is possible to create a single, monolithic foundation.

Illustrative embodiments have been described above. While the method in the present application is susceptible to various modifications and alternative forms, specific embodiments thereof have been shown by way of example in the drawings, and have been herein described in detail. It

should be understood, however, that the description herein of specific embodiments is not intended to limit the method in the present application to the particular forms disclosed, but on the contrary, the method in the present application is to cover all modifications, equivalents, and
5 alternatives falling within the spirit and scope of the method in the present application, as defined by the appended claims.

It will, of course, be appreciated that in the development of any such actual embodiment, numerous implementation-specific decisions must be made to
10 achieve the developer's specific goals, such as compliance with system-related and business-related constraints, which will vary from one implementation to another. Moreover, it will be appreciated that such a development effort might be complex and time-consuming, but, would nevertheless, be a routine undertaking for those of ordinary skill in the art,
15 having the benefit of this disclosure.

What is claimed is:

1. A hybrid method of erecting a cold box in the field utilizing prefabricated and field erected components, said method comprising the following steps:
 - 5 a. anchoring at least one column to a foundation in a substantially vertical orientation;
 - b. anchoring a pipe rack module to said foundation in a substantially vertical orientation, wherein said pipe rack module is in close proximity to said at least one column;
 - 10 c. attaching interconnecting piping between said pipe rack module and said at least one column;
 - d. anchoring at least four corner beams to the edge of said foundation in a substantially vertical orientation;
 - e. attaching prefabricated panels with bracing to said corner beams, to
15 form an enclosure around said column and piping; and
 - f. attaching a roof to said enclose.
2. The method of claim 1, wherein said pipe rack module is prefabricated.
- 20 3. The method of claim 1, wherein said pipe rack module comprises one or more elements selected from the group consisting of control valves, manual valves, sample connections, piping, pre-cut panels with valve actuators, instrumentation, vapo flash, lighting, ladders and platforms, pre-wired junction box, instrument/electrical cable trays, piping support, duct to
25 exchanger box, and the pump module.
4. The method of claim 1, wherein said at least one column comprises one or more elements selected from the group consisting of waste line, separator pots, large safety valve lines.

5. The method of claim 1, further comprising a second pipe rack module.
6. The method of claim 5, wherein said second pipe rack module comprises one or more elements selected from the group consisting of
5 waste line, separator pots, large safety valve lines.
7. The method of claim 1, wherein said prefabricated panels are attached to said corner beams by bolting.
- 10 8. The method of claim 1, wherein said prefabricated panels are connected vertically or horizontally.
9. The method of claim 8, wherein said prefabricated panels are attached to the edge of said foundation or to adjacent prefabricated panels with
15 bolts.

Fig. 1

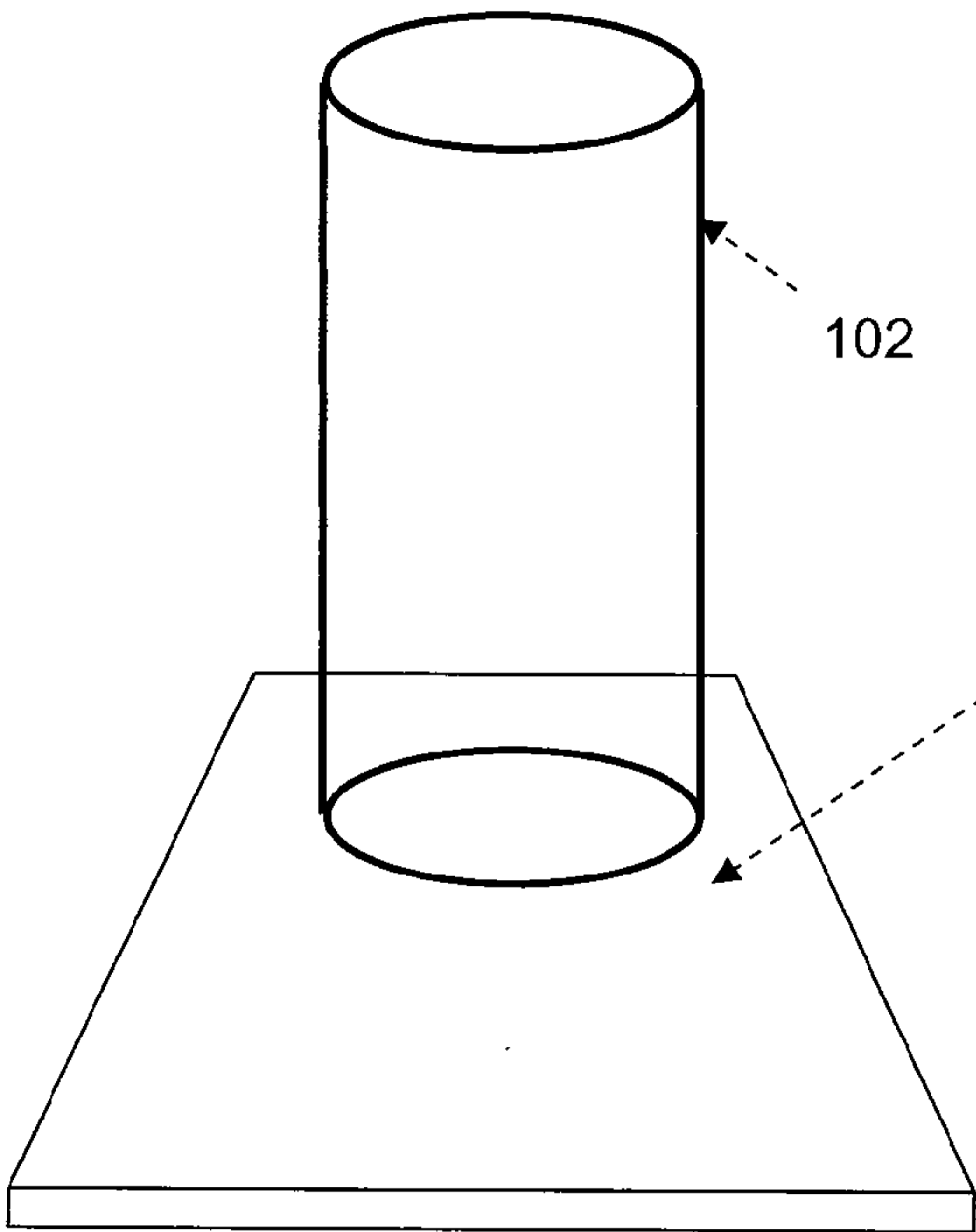

Fig. 2

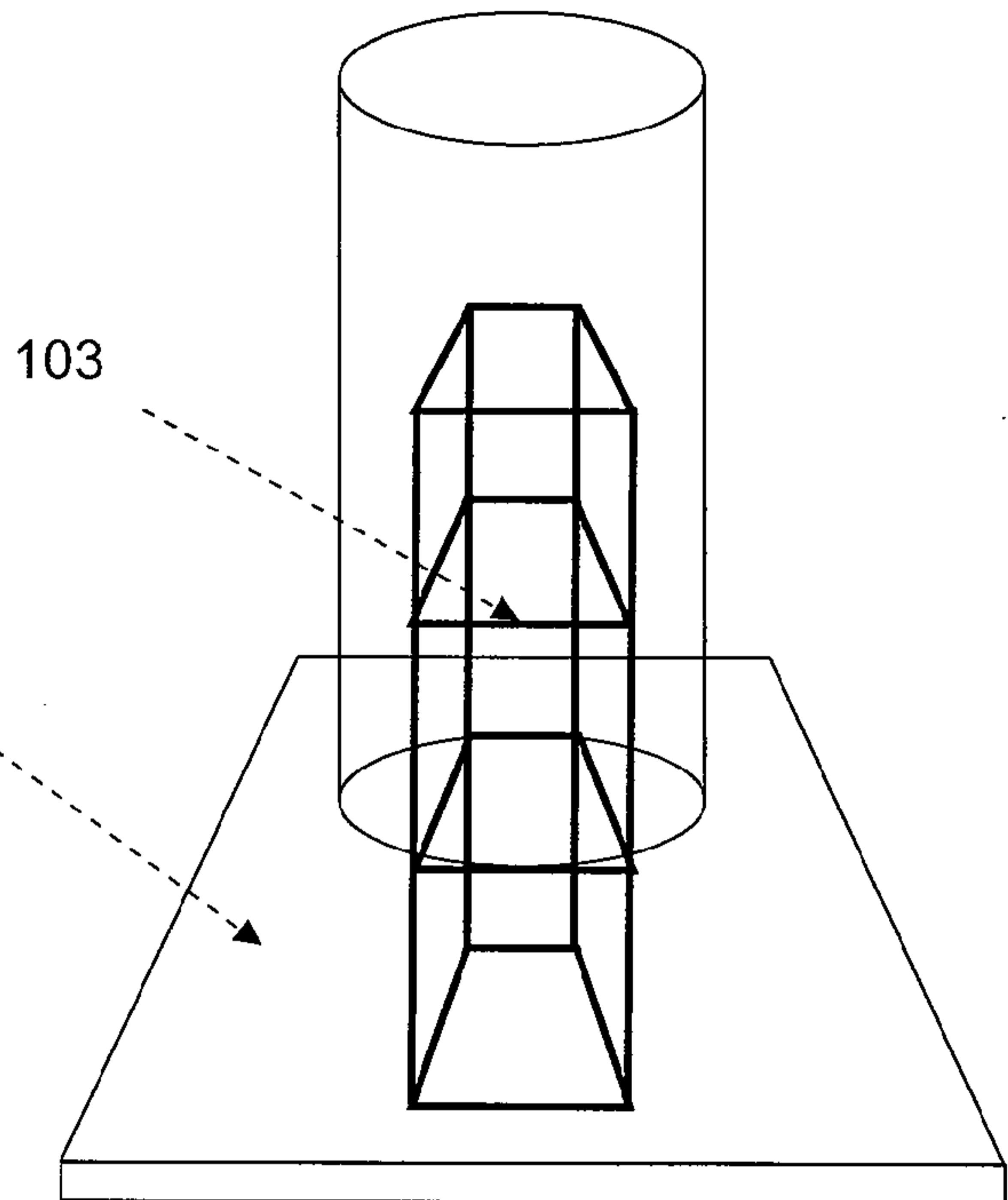

Fig. 3

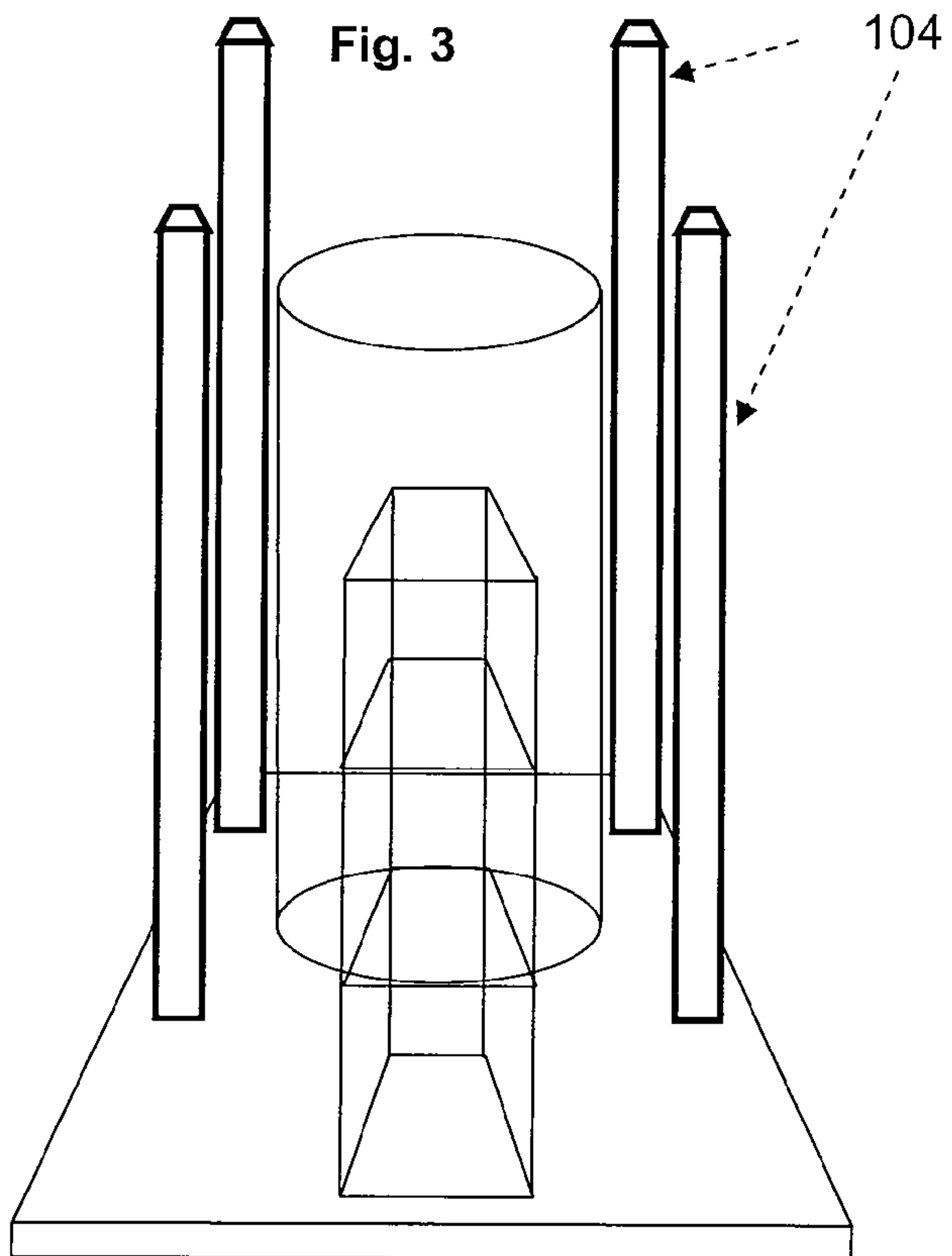

Fig. 4

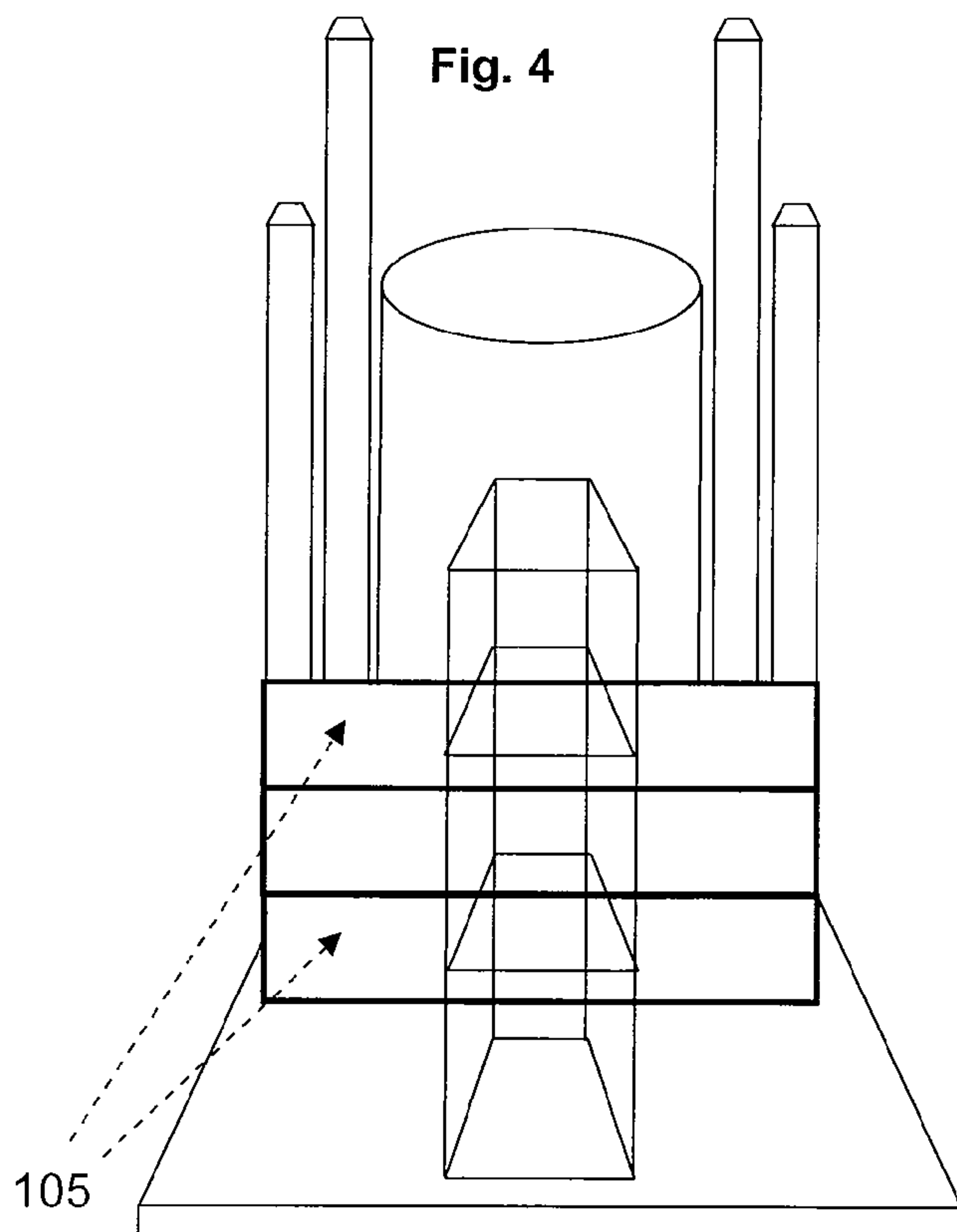

Fig. 5

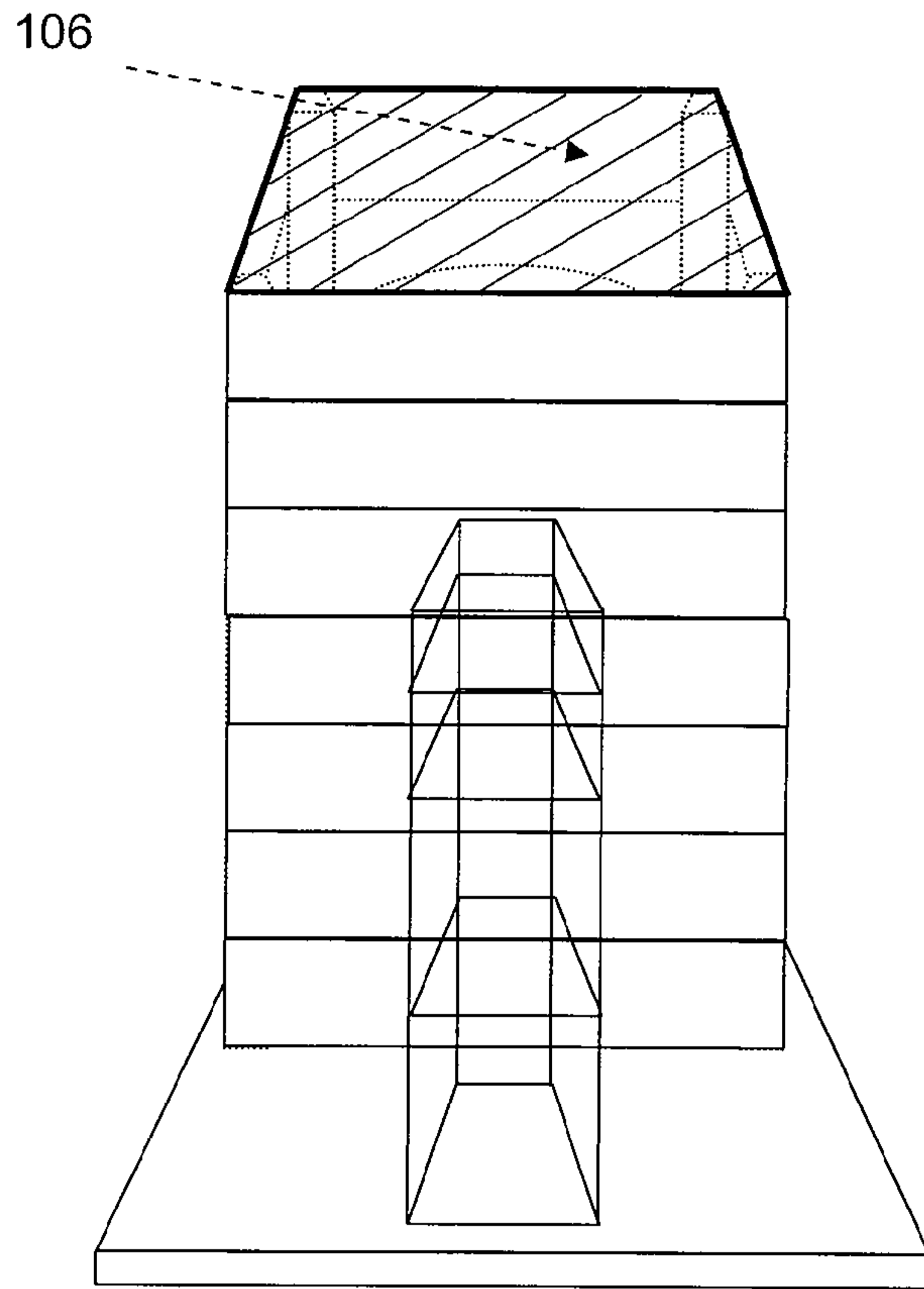

Fig. 5

106

